

## Unit 4: Physics on the Move

Question Number	Question	
1	Which of the following is the same unit as the farad?	
	Answer	Mark
	C	1

Question Number	Question	
2	An emf will only be induced across the wing tips of an aircraft if it is flying horizontally in	
	Answer	Mark
	D	1

Question Number	Question	
3	A top quark has a mass of $171 \frac{\text{GeV}}{c^2}$ . Its mass in kilograms is about	
	Answer	Mark
	C	1

Question Number	Question	
4	The following are four possible graphs of a quantity $Y$ plotted against another quantity $X$ .  <div style="text-align: center;"> <p style="text-align: center;">A                      B                      C                      D</p> </div> <p>Which graph best represents <math>Y</math> when it is the kinetic energy of an electron and <math>X</math> is its momentum?</p>	
	Answer	Mark
	B	1

Question Number	Question	
5	Which graph best represents $Y$ when it is the electric field strength between two parallel plates with a constant potential difference across them and $X$ is the distance apart of the plates?	
	Answer	Mark
	D	1

Question Number	Question	
6	Which graph best represents $Y$ when it is the radius of the circle described by an electron in a constant magnetic field at right angles to the path of the electron and $X$ is the momentum of the electron?	
	Answer	Mark
	A	1

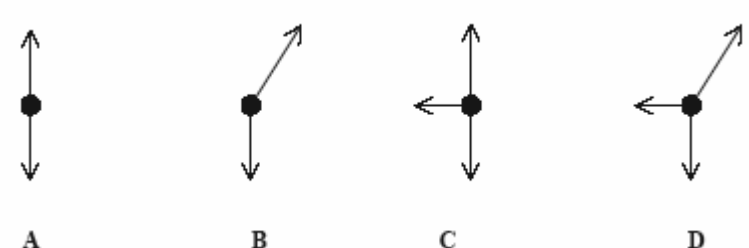
Question Number	Question	
7	Each of the diagrams below is a free-body force diagram representing the forces acting on a body.   <p style="text-align: center;">A                      B                      C                      D</p> <p>Which diagram best illustrates the forces acting on a charged sphere, supported on a nylon thread, in equilibrium alongside a second similarly charged sphere?</p>	
	Answer	Mark
	D	1

Question Number	Question	
8	A $\pi^+$ pion is composed of which combination of quarks?	
	Answer	Mark
	C	1

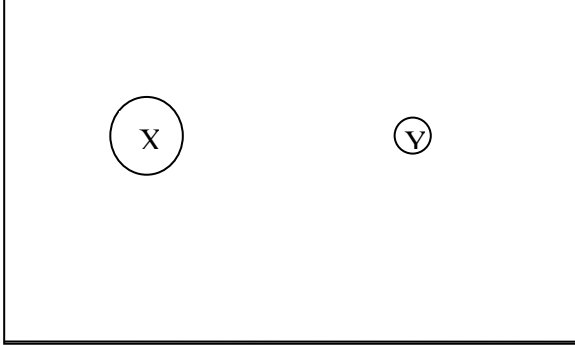
Question Number	Question	
9	<p>The diagram shows two charged spheres X and Y, of masses <math>2m</math> and <math>m</math> respectively, which are just prevented from falling under gravity by the uniform electric field between the two parallel plates. Use the diagram when answer in questions 9 and 10.</p> <div style="text-align: center;">  </div> <p>Which of the following is a property of a <b>uniform</b> electric field?</p>	
	Answer	Mark
	A	1

Question Number	Question	
10	If the plates are moved closer together	
	Answer	Mark
	B	1

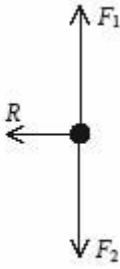
Question Number	Question	
11(a)	<p>Figure 1 shows the London Eye, a tourist attraction in the form of a very large wheel. Passengers ride in capsules, describing a vertical circle at constant speed. Figure 2 is a free-body force diagram showing the forces acting on a passenger in one of the capsules at point X of the circle.</p> <div style="display: flex; justify-content: space-around; align-items: center;"> <div style="text-align: center;">  <p>Figure 1</p> </div> <div style="text-align: center;">  <p>Figure 2</p> </div> </div> <p>A teacher asks the class why the forces <math>F_1</math> and <math>F_2</math> are equal and opposite. A student suggests that this is because of Newton's third law.</p>	
	Answer	Mark
	They act on the same body or do not act on different bodies (1) They are different types of, or they are not the same type of, force(1)	2

Question Number	Question	
11(b)	Explain why the forces $F_1$ and $F_2$ must be equal and opposite.	
	Answer	Mark
	As the passenger or capsule or wheel has <u>constant speed</u> (1) there is <u>No resultant tangential force</u> (acting on the passenger) (1)	2

Question Number	Question	
11(c)	State what causes the force $R$ .	
	Answer	Mark
	Friction between seat & person or push of capsule wall on person	1

Question Number	Question	
12(a)	State what is meant by the term <b>baryon</b> .	
	Answer	Mark
	A baryon is a (sub-atomic) particle made up of <u>3 quarks</u> (1)	1

Question Number	Question	
12(b)	In $\beta^-$ decay a neutron decays into a proton. Explain how the quark structure of the baryon changes in this process.	
	Answer	Mark
	n (ddu) $\rightarrow$ (1) p (duu) (1)	2

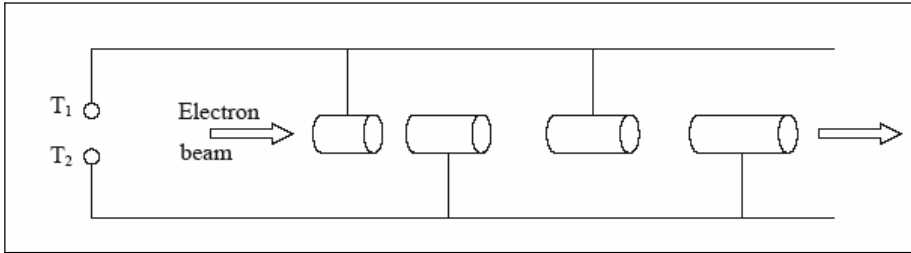
Question Number	Question	
13(a)	Quarks were discovered using the Stanford Linear Accelerator (SLAC). The diagram below shows the principle of a linear accelerator (LINAC). 	
	State what is connected between terminals $T_1$ and $T_2$ .	
	Answer	Mark
	High frequency or high voltage(1) Alternating or square wave voltage(1)	2

Question Number	Question	
13(b)	Explain why the electrons travel with constant velocity whilst in the cylinders.	
	Answer	Mark
	No electric field inside cylinders (due to shielding) (1) so no force (on electrons) (1)	2

Question Number	Question	
13(c)	Explain why the cylinders gradually increase in length along the accelerator.	
	Answer	Mark
	As speed increases (along the accelerator), (1) cylinders are made longer so that time in each stays the same(1)	2

Question Number	Question	Mark
14	Outline the experimental observations to which Rutherford is referring and explain how they led him to this deduction.	
	Answer	5
QWC(i-iii)	The answer must be clear, use an appropriate style and be organised in a logical sequence $\alpha$ -particles fired at (named) metal (film) (1) in a vacuum (1) Most went straight through or suffered small deflections. (1) A few were reflected through large angles or some were reflected along their original path (1) suggesting the mass or charge of the atom was concentrated in a very small volume(1)	

Question Number	Question	Mark
15 (a)(i)	Show that the energy stored in a 2200 $\mu\text{F}$ capacitor is of approximately 0.16J. Energy = .....	
	Answer	2
	Use of $E = \frac{1}{2} CV^2$ (1) Answer [0.158 J] (1)  $E = \frac{1}{2} CV^2 = 0.5 \times 2200 \times 10^{-6} \text{ F} \times (12 \text{ V})^2$ $E = 0.158 \text{ J}$	

Question Number	Question	Mark
15 (a)(ii)	What is the efficiency of the electric motor in this situation? Efficiency = .....	
	Answer	2
	Correct substitution into $\Delta E_p = \Delta mgh$ (1) Answer 0.75 [75%] (1)  $\Delta E_p = 0.05 \text{ kg} \times 9.8 \text{ N kg}^{-1} \times 0.24 \text{ m} [= 0.12 \text{ J}]$ Efficiency = $0.12 \text{ J} \div 0.16 \text{ J} = 0.75$ [75%]	

Question Number	Question	Mark
15(b)(i)	The capacitor is then charged to 12 V again and then discharged through a 16 $\Omega$ resistor.  Show that the time constant for this discharge is approximately 35 ms.	
	Answer	1
	$(t = CR) = 2200 \times 10^{-6} \text{ (F)} \times 16 \text{ (\Omega)} = 35.2 \text{ (ms)}$ (1)	

Question Number	Question	Mark
15(b)(ii)	Sketch a graph of current against time for this discharge on the grid below. You should indicate the current at $t = 0$ and $t = 35$ ms.	
	Answer	3
	Curve starting on $I$ axis but not reaching $t$ axis(1)  $I_0 = 1.6 \text{ V} / 16\Omega = 100 \text{ mA}$ shown on axis(1)  Curve passing through about 37 mA at $t = 35$ ms(1)	

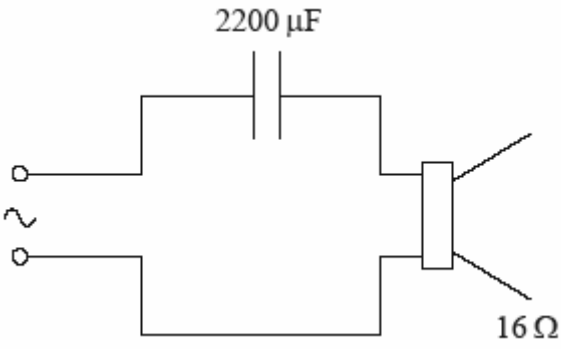
Question Number	Question	Mark
15(c) (i)	Capacitors are used in audio systems when connecting the amplifier to the loudspeaker. In one such circuit the capacitor has a value of $2200 \mu\text{F}$ and the loudspeaker has a resistance of $16 \Omega$ .  <div style="text-align: center;">  </div> The loudspeaker produces longitudinal sound waves. What is meant by longitudinal in this context?	
	Answer	2
	The vibrations of the air particles (1) are parallel to the direction of travel of the wave (energy) (1)	

Question Number	Question	Mark
15(c)(ii)	Ideally, the time constant for such a circuit should be much greater than the time period of the lowest frequency note. Discuss the extent to which this circuit would be effective if the lowest frequency note is 20 Hz.	
	Answer	2
	$T = 1/f = 50 \text{ ms}$ (1)  Sensible comment related to time constant of 35 ms(1)	

Question Number	Question	
16(a)	<p>In their famous experiment conducted in 1932, Cockcroft and Walton accelerated protons through a potential difference of 300 kV and used them to bombard a lithium (<math>{}^7_3\text{Li}</math>) target. They found that two alpha particles were produced. The energy of the alpha particles was subsequently calculated from the tracks they made in a cloud chamber.</p> <p>Complete the nuclear equation for this event.</p> ${}^7_3\text{Li} + \quad \longrightarrow$	
	<p>Answer</p> ${}^7_3\text{Li} + {}^1_1\text{p} = 2{}^4_2\text{He}$ <p>completing LHS (1) completing RHS(1)</p>	<p>Mark</p> <p>2</p>

Question Number	Question	
16(b)(i)	<p>Cockcroft and Walton reported to the Royal Society that "if momentum is conserved in the process, then each of the <math>\alpha</math>-particles must take up equal amounts of energy, and from the observed range of the <math>\alpha</math>-particles we conclude that an energy of 17.2 million electron-volts [MeV] would be liberated in this disintegration process."</p> <p>State two other properties, in addition to momentum, that are conserved in such a process.</p>	
	<p>Answer</p> <p>Charge (1) (mass/) energy (1)</p>	<p>Mark</p> <p>2</p>

Question Number	Question	
(b)(ii)	<p>Use the data below to show that the energy released in this process is approximately <math>2.8 \times 10^{-12}</math> J.</p> <p style="text-align: center;">           Mass of lithium nucleus = 7.0143 u            Mass of proton = 1.0073 u            Mass of <math>\alpha</math>-particle = 4.0015 u         </p>	
	<p>Answer</p> <p>Mass of Li + p = 7.0143 u + 1.0073 u = 8.0216 u (1)            Mass of 2 <math>\alpha</math>-particles = 2 <math>\times</math> 4.0015 u = 8.0030 u (1)  <math>\Delta m = 8.0216 \text{ u} - 8.0030 \text{ u} = 0.0186 \text{ u}</math>  <math>= 0.0186 \times 1.66 \times 10^{-27} \text{ kg} = 3.09 \times 10^{-29} \text{ kg}</math> (1)  <math>\Delta E = c^2 \Delta m = (3.00 \times 10^8 \text{ m s}^{-1})^2 \times 3.09 \times 10^{-29} \text{ kg} = 2.78 \times 10^{-12} \text{ J}</math> (1)</p> <p>[Allow ecf from equation]</p>	<p>Mark</p> <p>4</p>

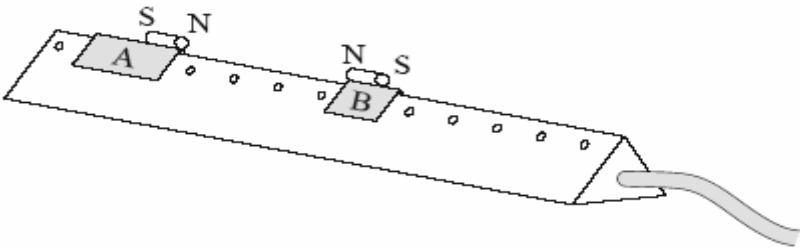

Question Number	Question	
(b)(iii)	Hence discuss the extent to which Cockcroft and Walton's results confirm Einstein's prediction that $E$ is equal to $mc^2$ .	
	Answer	Mark
	$= \frac{2.78 \times 10^{-12} \text{ J}}{1.60 \times 10^{-19} \text{ J eV}^{-1}} = 1.74 \times 10^7 \text{ eV} = 17.4 \text{ MeV} \quad (1)$ <p>The incoming proton has an energy of 300 keV = 0.30 MeV (1)  So total energy = 17.4 MeV + 0.3 MeV = 17.7 MeV (1)  The calculated energy differs by</p> $\frac{17.7 \text{ MeV} - 17.2 \text{ MeV}}{\frac{1}{2}(17.7 + 17.2) \text{ MeV}} \times 100\% \approx 3\% \quad (1)$ <p>The experiment therefore provides strong evidence for Einstein's prediction (1)</p>	5

Question Number	Question	
17 (a)	State the principle of conservation of linear momentum.	
	Answer	Mark
	<u>Total</u> (linear) momentum of a system is constant, (1) provided no (resultant) <u>external</u> force acts on the system(1)	2
Question Number	Question	
17 (b)	<p>The diagram shows two gliders on an air track. The magnets on the top of the gliders repel each other. The mass of glider A is 300 g and that of glider B is 100 g.</p>  <p>Glider A is given a push to start it moving towards glider B which is initially at rest.</p> <p>Describe how you could determine the velocity of A before the gliders interact and the velocities of both A and B after the interaction. You may add to the diagram to show any additional apparatus required.</p>	
	Answer	Mark
QWC(i-iii)	<p>The answer must be clear, use an appropriate style and be organised in a logical sequence</p> <p>Use of a light gate (1) Use of second light gate(1)</p> <p>Connected to timer or interface + computer (accept 'log-it') (1)</p> <p>Cards on gliders(1)</p> <p>Measure length of cards(1) Velocity = length ÷ time(1)</p>	6
Question Number	Question	
17 (c)	<p>A student obtains the following velocities:</p> <p>velocity of A before interaction = <math>5.2 \text{ cm s}^{-1}</math> velocity of A after interaction = <math>2.7 \text{ cm s}^{-1}</math> velocity of B after interaction = <math>7.5 \text{ cm s}^{-1}</math></p> <p>Show if these results confirm that momentum is conserved in the interaction;</p>	
	Answer	Mark
	Multiplies mass × velocity to find at least one momentum (1) $1560 \text{ g cm s}^{-1}$ ( $0.0156 \text{ kg m s}^{-1}$ ) before <u>and</u> after (1)	2

Question Number	Question	
18(a)(i)	<p>A do-it-yourself company is advertising a wind turbine that they state can deliver a power of 1 kW.</p> <p>Their specification provides the following data:</p> <ul style="list-style-type: none"> <li>• area swept out by the blades in one revolution = 2.4 m<sup>2</sup></li> <li>• power output = 1 kW at a wind speed of 12.5 m s<sup>-1</sup></li> <li>• typical operating speed of blades = 600 revolutions per minute</li> </ul> <p>Show that the length of each blade is approximately 0.9 m.</p>	
	Answer	Mark
	Use of $A = \pi r^2$ leading to 0.87 (m) (1)	1

Question Number	Question	
18(a)(ii)	Show that the angular velocity of the blades at the typical operating speed is approximately 63 rad s <sup>-1</sup> .	
	Answer	Mark
	Correct use of $\omega = 2\pi/t$ leading to 62.8 (rad s <sup>-1</sup> ) (1)	1

Question Number	Question	
18(a)(iii)	Calculate the speed at which the tips of the blades will then be traveling. Speed =	
	Answer	Mark
	Correct use of $v = r\omega = 55 \text{ m s}^{-1}$ [allow use of show that value] (1)	1

Question Number	Question	
18(b)(i)	<p>The theoretical power available from a wind turbine is given by</p> $P = \frac{1}{2} \rho A v^3$ <p>where <math>\rho</math> = density of air = 1.3 kg m<sup>-3</sup>  <math>A</math> = area swept out by blades per revolution  <math>v</math> = wind speed</p> <p>Show that when the wind speed is 12.5 m s<sup>-1</sup>, the theoretical power from the advertised turbine is about 3 kW</p> <p>Power = .....</p>	
	Answer	Mark
	Substitution into $P = \frac{1}{2} \rho A v^3$ (1)	2
	3047 (W) (1)	

Question Number	Question	
18(b)(ii)	Suggest 2 reasons why the actual power is less than the theoretical power.	
	Answer	mark
	Air is hitting at an angle/all air not stopped by blades (1)	2
	Energy changes to heat and sound (1)	

Question Number	Question	
18(c)(i)	The manufacturer has to ensure that when the turbine is attached to a chimney stack, the force exerted on the chimney does not cause it to collapse. The turbine is designed to cut out at a wind speed of $14 \text{ m s}^{-1}$ .  Calculate the mass of air hitting the blades each second when the wind speed is $14 \text{ m s}^{-1}$ . Mass of air =	
	Answer	Mark
	Attempts to find volume per second ( $A \times v$ ) (1)  $44 \text{ kg s}^{-1}$ (1)	2

Question Number	Question	
18(c)(ii)	Hence calculate the maximum force that the wind could exert on the blades.  Maximum force = .....	
	Answer	Mark
	Use of $F = \Delta mv / \Delta t$ (1)  $F = 610 \text{ N}$ (1)	2

Question Number	Question	
18(d)	The average wind speed in the UK is $5.8 \text{ m s}^{-1}$ , which results in an actual average power output of 100W. Discuss whether it would be better for the environment to replace some filament light bulbs with low energy bulbs than to use this turbine. Assume each filament light bulb is rated at 100 W and each low energy bulb is rated at 11 W.	
	Answer	Mark
QWC(i,iii)	Recognises that 100 W is produced over 24 hours (1) Estimates if this would fulfil lighting needs for a day(1) Estimates energy used by low energy bulbs in day(1) Conclusion(2) The answer must be clear and be organised in a logical sequence  <u>Example:</u>  The 100 W is an average over the whole day. Most households would use light bulbs for 6 hours a day in no more than 4 rooms, so this would mean no other energy was needed for lighting. 4 low energy bulbs would be 44 W for 6 each hours so would require energy from the National grid.  [Accept an argument based on more light bulbs/longer hours that leads to the opposite conclusion]	5