

Examiners' Report
June 2019

GCE Physics 9PH0 03

Edexcel and BTEC Qualifications

Edexcel and BTEC qualifications come from Pearson, the UK's largest awarding body. We provide a wide range of qualifications including academic, vocational, occupational and specific programmes for employers. For further information visit our qualifications websites at www.edexcel.com or www.btec.co.uk.

Alternatively, you can get in touch with us using the details on our contact us page at www.edexcel.com/contactus.



Giving you insight to inform next steps

ResultsPlus is Pearson's free online service giving instant and detailed analysis of your students' exam results.

- See students' scores for every exam question.
- Understand how your students' performance compares with class and national averages.
- Identify potential topics, skills and types of question where students may need to develop their learning further.

For more information on ResultsPlus, or to log in, visit www.edexcel.com/resultsplus. Your exams officer will be able to set up your ResultsPlus account in minutes via Edexcel Online.

Pearson: helping people progress, everywhere

Pearson aspires to be the world's leading learning company. Our aim is to help everyone progress in their lives through education. We believe in every kind of learning, for all kinds of people, wherever they are in the world. We've been involved in education for over 150 years, and by working across 70 countries, in 100 languages, we have built an international reputation for our commitment to high standards and raising achievement through innovation in education. Find out more about how we can help you and your students at: www.pearson.com/uk.

June 2019

Publications Code 9PH0_03_1906_ER

All the material in this publication is copyright
© Pearson Education Ltd 2019

Introduction

This paper comprises short open, open-response, calculation and extended writing questions worth a total of 120 marks. The questions draw on a range of the topics in the specification, and include synoptic questions drawing on two or more different topics. The paper also includes questions that assess conceptual and theoretical understanding of experimental methods (indirect practical skills), some of which draw on candidates' experiences of the core practicals.

The paper gave candidates the opportunity to demonstrate their understanding of a wide range of topics from the specification, with all of the questions eliciting responses across the range of marks. On the whole, linkage questions in this paper tended to generate better responses than in previous series, with candidates demonstrating an improved ability to link ideas coherently in the context provided in the question.

There is evidence that candidates are not paying sufficient attention to the command words used in the question. In a number of cases, questions requiring an explanation were answered with a description by several candidates.

In general, calculation and 'show that' questions gave candidates an opportunity to demonstrate their problem solving skills to good effect. Some very good responses were seen for such questions, with well crafted solutions which were accurate and clearly set out. In some calculation questions the final mark was not awarded due to a missing unit. This was seen in Q02(b)(i), Q05(a), and Q09(b)(ii).

There were instances where candidates disadvantaged themselves by not using suitably precise language. This was particularly the case in some of the questions testing indirect practical skills, such as Q07(a)(i) and Q11(a), where candidates sometimes had knowledge of the method, but could not express it accurately and succinctly.

Some candidates did not seem to understand the language and processes of quantifying uncertainties in practical work. In particular, candidates struggled to use the terms 'accuracy', 'error', 'precision', 'resolution' and 'uncertainty' correctly.

The space allowed for responses was usually sufficient. However, candidates need to remember that the space provided does not have to be filled. Candidates should be encouraged to consider the number of marks available for a question, and to use this to determine the length of response required. If candidates either need more space or want to replace an answer with a different one, they should indicate clearly where the response they wish to be marked by examiners can be found.

Question 1 (a)

The great majority of candidates gave the correct answer to this. A few repeated the question, and called it a zero error. Some candidates seemed to feel that systematic was not enough and they had to give an alternative as well.

Question 1 (b)

Few candidates appreciated the need to refer to both different orientations/directions and different locations. In a number of responses that did refer to measuring at different orientations the procedure wasn't clearly expressed. A few candidates neglected to say they would take a mean, and some candidates added reasons, eg reduces effect of random error. They had not followed the command word to describe, but rather explained instead.

(b) Describe the procedure she should follow to determine an accurate value for the external diameter of the tube.

(3)

After checking the zero error, measure the diameter of the tube in at least 5 different places and orientations. Find a mean average of these results for the diameter. When tightening the micrometer, use the Rine adjustment knob to avoid overtightening so the results are consistent.



This candidate has stated enough for all three marks to be awarded. The precaution about tightening the micrometer is a correct practical detail about using the micrometer, although not necessary as a response to this question. The question states that the student checks the micrometer for a zero error, and so this comment is also unnecessary.

(b) Describe the procedure she should follow to determine an accurate value for the external diameter of the tube.

(3)

The engineer should take readings from multiple locations along the metal tube and take a mean of these readings / identify any anomalies in her data. She should take the zero error value off each reading.



This response only scores 2 marks, as there is no indication that the student should read the diameter in different orientations. The reference to identifying anomalies does not gain a mark.

Question 1 (c)

Very few candidates gave a sensible answer about the length varying slightly. Most compared the digital micrometer with the ones they used at school, which had a much lower resolution, or said the resolution had to be the same as that of the diameter.

(c) The engineer determined the length of the tube using the micrometer. The reading on the micrometer scale was 45.043 mm. She recorded the reading as 45.0 mm. State why recording a reading of 45.043 mm could not be justified.

(1)

It is to a very high resolution and the diameter may vary along the tube so 45.0 mm would be more precise.



This response is worth 1 mark, as the candidate has indicated that there may be a variation along the length of the tube that would invalidate using a 3 decimal place answer, even though the micrometer can record distances to this resolution.

- (c) The engineer determined the length of the tube using the micrometer. The reading on the micrometer scale was 45.043 mm. She recorded the reading as 45.0 mm. State why recording a reading of 45.043 mm could not be justified. (1)

There are too many significant figures, 0.043 mm is irrelevant.



'Too many significant figures' only restates what we know from the question. To gain the mark the response needs to indicate why 5 significant figures are too many in this case.

Question 2 (a)

Few candidates knew the correct symbol for a heater and a thermistor was sometimes drawn. Some candidates over-elaborated, eg drawing potential divider circuits incorrectly. Most candidates scored 2 marks, but a surprising number of candidates connected an aluminium block into the circuit, or drew the heater with a single wire connection. A significant minority of responses had the ammeter symbol drawn as a circle containing an 'I'. Many circuit diagrams were drawn freehand, with unexpected gaps and lines drawn through components.

At this level, it is expected that candidates should be able to draw accurate circuit diagrams.

2 A student determined the specific heat capacity of aluminium.

She used an electrical heater to heat an aluminium block and measured the temperature of the block with a digital thermometer.

(a) She connected the electrical heater into a circuit and took measurements to determine the power of the heater.

Draw a circuit diagram of a suitable circuit.

(2)

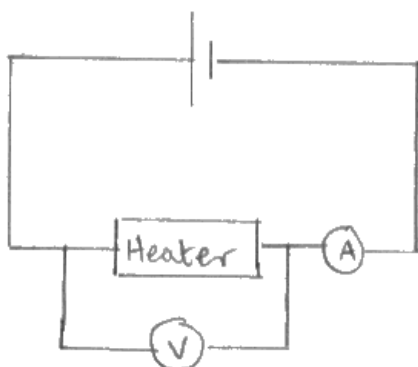

This simple circuit is enough to score full marks.

2 A student determined the specific heat capacity of aluminium.

She used an electrical heater to heat an aluminium block and measured the temperature of the block with a digital thermometer.

(a) She connected the electrical heater into a circuit and took measurements to determine the power of the heater.

Draw a circuit diagram of a suitable circuit.

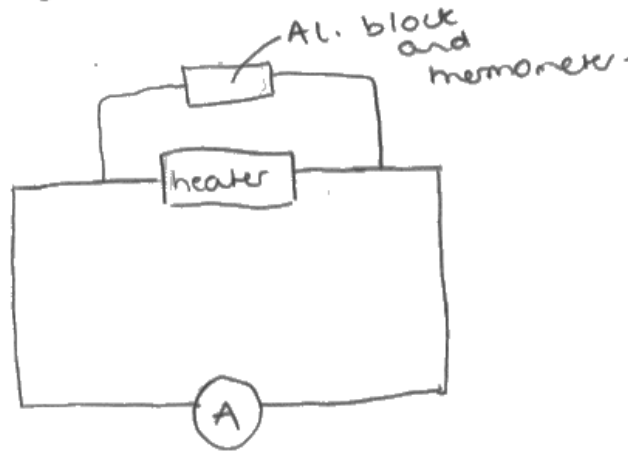

This response scores zero. No power supply is shown, and the voltmeter has been omitted from the circuit. The aluminium block seems to be connected into the circuit, in parallel with the heater.

Question 2 (b) (i)

Responses to this question were mostly correct. For those candidates who did not obtain the correct numerical answer, this was often because they read a single pair of coordinates from the graph, missing the fact that the line did not pass through the origin. Adding 273 to the change in temperature was seen occasionally. Some candidates had the correct numerical answer but didn't score full marks due to a unit error. These candidates had either missed off the units from their final answer, or had given incorrect units. Surprisingly, a number of candidates used C^{-1} instead of $^{\circ}C^{-1}$. The units of latent heat capacity were commonly seen.

(i) Determine the specific heat capacity of aluminium.

power of heater = 37.5 W

mass of aluminium block = 0.986 kg

(3)

$$\Delta E = mc\Delta\theta$$

$$P = \frac{W}{t} \rightarrow 37.5 = \frac{W}{500} \rightarrow W = 37.5 \times 500 = 18750 \text{ J}$$

$$18750 = 0.986 \times (36 - 16) \times c$$

$$18750 = 0.986 \times 20 \times c$$

$$c = \frac{18750}{0.986 \times 20} = \frac{18750}{19.72} = 950.8$$

Specific heat capacity of aluminium = $950.8 \text{ J kg}^{-1}^{\circ}C^{-1}$



This is a clearly set out solution which is worth 3 marks. All of the candidate's working is included, and numerical substitutions have been made before re-arranging the equations.



Show all of your working in calculation and 'show that' questions.

(i) Determine the specific heat capacity of aluminium.

power of heater = 37.5 W

mass of aluminium block = 0.986 kg

(3)

$$\Delta E = mc\Delta\theta$$

$$p = \frac{E}{t} \quad t = 500$$

$$c = \frac{\Delta E}{m\Delta\theta}$$

$$\Delta\theta = 20$$

$$\Delta E = 37.5 \times 500$$

$$c = \frac{18750}{0.986 \times 20} = 950.8$$

$$= 18750 \text{ J}$$

$$= 951 \text{ (2sf)} \text{ J kg}^{-1} \text{ K}^{-1}$$

Specific heat capacity of aluminium = 951 J kg⁻¹ K⁻¹



ResultsPlus
Examiner Comments

This solution is clearly set out and scores full marks for a correct answer. However, notice how the candidate has rearranged the equations before substituting numerical values. If these rearrangements had been incorrect, then the candidate would have missed out on method marks, as a 'use of' mark is only awarded if a substitution into a correct physical equation is shown.



ResultsPlus
Examiner Tip

Substitute numerical values before rearranging an equation.

Question 2 (b) (ii)

Many candidates referred to heat being 'lost' or 'not all the heat being transferred' to the block. Not all realised they should attempt a calculation of time or temperature rise.

- (ii) The student looked up the accepted value for the specific heat capacity of aluminium. Using this value, the student predicted that it should have taken 240 s for the temperature of the aluminium block to increase by 10°C .

Explain the difference between the predicted time and the student's actual observations.

(2)

The student's observations are close to the predicted time as a 240s the temperature has raised from 16°C to 25.5°C or 26°C rounded to two significant figures. As a result the student's results are very close out by only about 0.5°C .



ResultsPlus
Examiner Comments

This response says enough for mark point 1 to be awarded, as the candidate has used the data provided in the graph to check out the student's prediction. However, the candidate has not explained why the times are only very close (and not the same).



ResultsPlus
Examiner Tip

Ensure that you give a reason as part of your answer to an 'explain' question.

- (ii) The student looked up the accepted value for the specific heat capacity of aluminium. Using this value, the student predicted that it should have taken 240s for the temperature of the aluminium block to increase by 10°C.

Explain the difference between the predicted time and the student's actual observations. (2)

The predicted time doesn't take into account external factors like the initial temperature of the room / aluminium. So the predicted time should be lower than the actual time.



This response is too vague for credit to be given. The candidate hasn't used the data in their explanation, and the reference to external factors doesn't mention energy transfer to the surroundings.

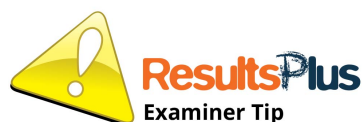

If numerical data is provided, be sure to use this data in your explanation.

Question 3 (a)

This question was often quite well answered. Many candidates realised that there would be an uncertainty of 0.05 cm in each reading leading to an uncertainty in r of $2 \times 0.05 = 0.1$ cm. Credit was not given for a statement that the resolution was 0.1 cm or that the uncertainty at each end would be 0.1 cm. However, too often there was a lack of clarity in the reason for using 1 mm as total uncertainty, although the best answers made this step clear.

3 A student was investigating the forces involved in circular motion.

He placed a small coin on a horizontal turntable as shown. The turntable was connected to a driver unit so that it could be rotated at a constant rate.

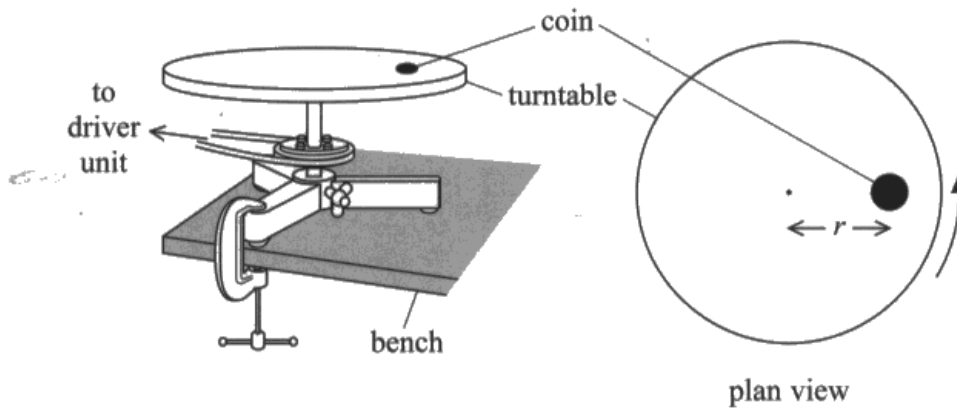

(a) The student measured the distance r between the centre of the turntable and the centre of the coin, with a metre rule as shown.

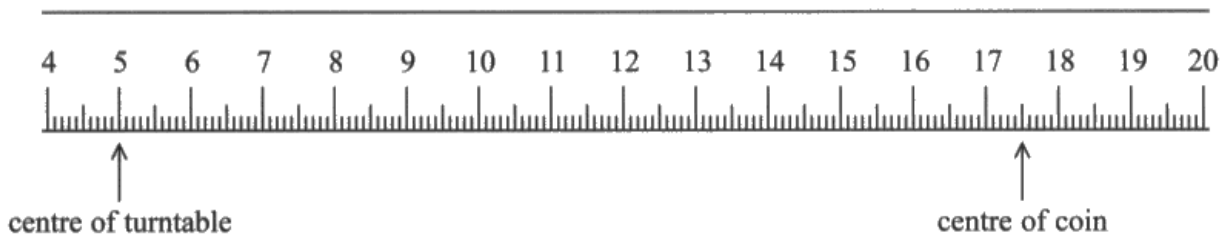

Explain why the percentage uncertainty in the value of r is about 1%.
Your answer should include a calculation.

(3)

Uncertainty due to measuring is ± 0.05 cm
on each side so total uncertainty is ± 0.1 cm
 $\frac{0.1}{12.5} = 0.1 - 8 \times 10^{-3} = 0.8\%$ which is
approximately 1%. so
the ~~percentage~~ the % in abs of r is about 1%.

This is a clearly explained solution leading to a correct answer.

3 A student was investigating the forces involved in circular motion.

He placed a small coin on a horizontal turntable as shown. The turntable was connected to a driver unit so that it could be rotated at a constant rate.

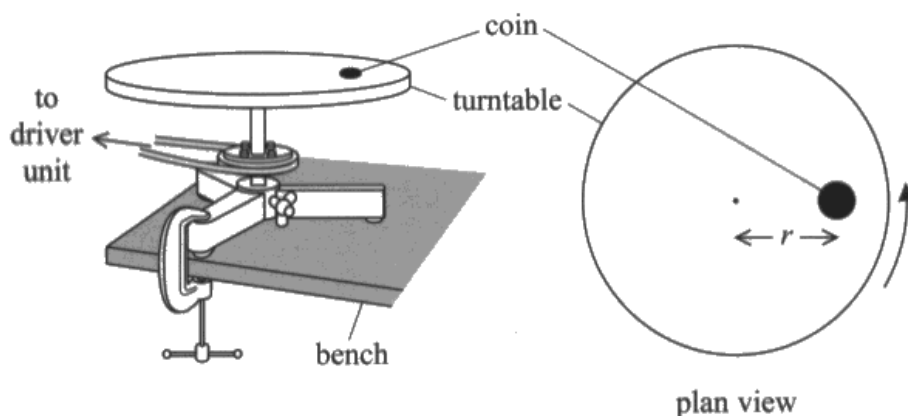

(a) The student measured the distance r between the centre of the turntable and the centre of the coin, with a metre rule as shown.

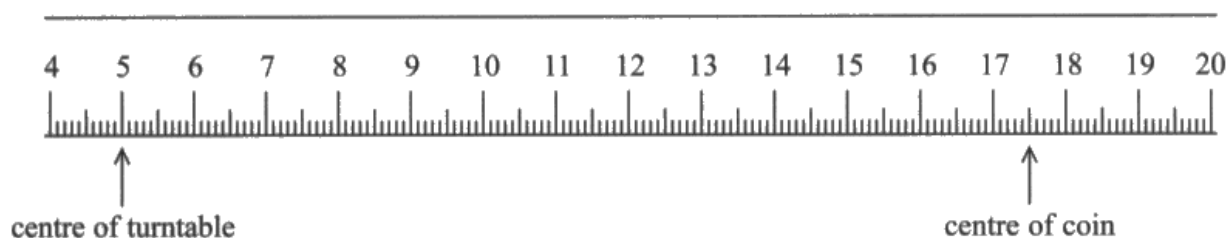

Explain why the percentage uncertainty in the value of r is about 1%.
Your answer should include a calculation.

(3)

The smallest demonstration is 1mm

distance measured is 125 mm

$$\frac{1 \text{ mm}}{125 \text{ mm}} = 0.8\% \text{ uncertainty value}$$

This candidate has used the resolution of the metre rule without making it clear that this is because the value for the radius is derived from two readings. This response scores 2 marks.

3 A student was investigating the forces involved in circular motion.

He placed a small coin on a horizontal turntable as shown. The turntable was connected to a driver unit so that it could be rotated at a constant rate.

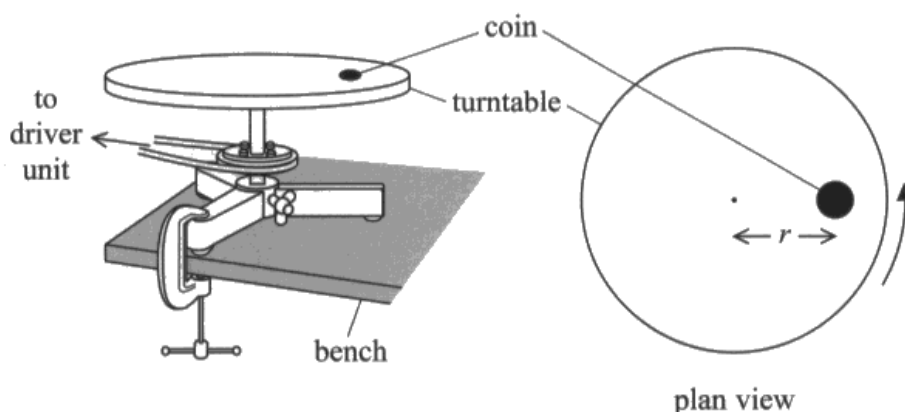

(a) The student measured the distance r between the centre of the turntable and the centre of the coin, with a metre rule as shown.

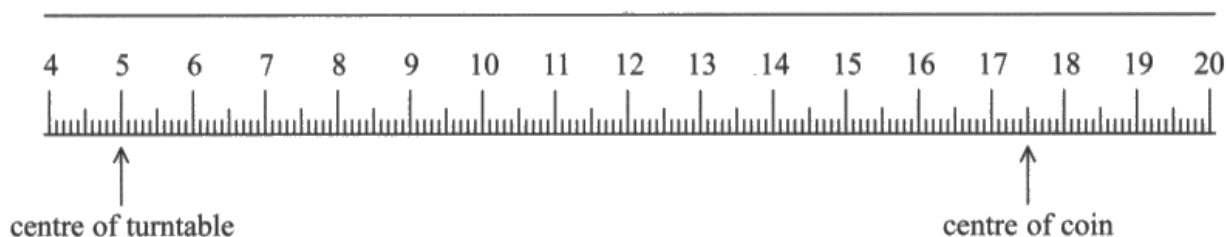

Explain why the percentage uncertainty in the value of r is about 1%.

Your answer should include a calculation.

$$\% U = \frac{\frac{1}{2} \text{ resolution}}{\text{mean}} = \frac{\frac{1}{2} (1 \text{ mm})}{12.5 \text{ cm}} = \frac{\frac{1}{2} (1 \times 10^{-3} \text{ m})}{0.125 \text{ m}} \times 100 \quad (3)$$

$$= 0.4\%$$



In this response the candidate has used half the resolution of the metre rule, but forgotten that two readings are being made to determine a value for the radius. The final answer is incorrect, so only mark point 1 can be awarded.



The uncertainty in each reading is half the resolution of the measuring instrument.

Question 3 (b) (i)

Many candidates incorrectly said that the purpose of calculating a mean was to reduce random errors instead of saying that it was to reduce the effect of random errors. In many responses the purpose was incorrectly linked to anomalous readings. The relatively large number of incorrect responses tends to indicate that some candidates may not have considered the purpose of calculating a mean in the required amount of detail.

- (b) The student switched on the driver unit and increased the rate of rotation until the coin slid off the turntable. He read the angular velocity ω of the turntable from a digital display on the driver unit. He then replaced the coin in the original position on the turntable and repeated the procedure.

His results are shown.

$\omega / \text{rad s}^{-1}$				
0.125	0.112	0.118	0.123	0.116

- (i) The student used the results to calculate a mean value of ω .

State the purpose of calculating a mean.

(1)

TO reduce the effects of random errors.



This response gives a clear reason for calculating a mean value.

- (b) The student switched on the driver unit and increased the rate of rotation until the coin slid off the turntable. He read the angular velocity ω of the turntable from a digital display on the driver unit. He then replaced the coin in the original position on the turntable and repeated the procedure.

His results are shown.

$\omega / \text{rad s}^{-1}$				
0.125	0.112	0.118	0.123	0.116

- (i) The student used the results to calculate a mean value of ω .

State the purpose of calculating a mean.

(1)

To find the average value, sometimes call the results



ResultsPlus
Examiner Comments

'Smooth out the results' is not a technical description of the purpose of calculating a mean.



ResultsPlus
Examiner Tip

Always use correct technical language.

Question 3 (b) (ii) - (iii)

In Q03(b)(ii), most candidates knew what to do and obtained a correct numerical answer. Giving the answer to too many significant figures was often the reason why candidates did not achieve full marks. It doesn't make sense to estimate the percentage uncertainty to 2 decimal places, hence the answer should have been given to 1 or 2 significant figures in this case. Some candidates tried to exclude anomalies, or take the full range rather than half the range.

Q03(b)(iii) was often well answered but some squared the percentage error in ω instead of multiplying it by 2. Some candidates also multiplied the percentage error in ω by the percentage error in r .

(ii) Calculate the percentage uncertainty in the mean value of ω .

(3)

$$\text{Mean} = \frac{0.125 + 0.112 + 0.118 + 0.123 + 0.116}{5} = 0.119$$

half difference

$$\frac{0.0065}{0.119} \times 100 = 5.47\%$$

$$\text{Percentage uncertainty} = 5.47\%$$

(iii) The student used ω and r to calculate the centripetal acceleration of the coin at the instant it started to slide.

Calculate the percentage uncertainty in this centripetal acceleration.

(3)

$$a = r\omega^2$$

$$\begin{aligned} \%U_a &= 1.28\% + 5.47\% + 5.47\% \\ &= 12.2\% \end{aligned}$$

$$\text{Percentage uncertainty} = 12.2\%$$



In Q03(b)(ii), the candidate has used the data to calculate a mean value, and the half range ('half difference') has been used to calculate the % uncertainty. The value is correct, but expressed to 3 significant figures. Only 1 decimal place is justified here, and so the response is worth 2 marks.

In Q03(b)(iii), the % uncertainty is given to 1 decimal place, which is fine for 3 marks to be awarded.



When calculating % uncertainties beware of giving too many decimal places in your answer.

(ii) Calculate the percentage uncertainty in the mean value of ω .

(3)

$$\omega = \frac{0.125 + 0.112 + 0.118 + 0.123 + 0.116}{5}$$

$$= 0.1208 \text{ rad s}^{-1}$$

$$\Delta \omega = \pm 0.001 \text{ rad s}^{-1}$$

$$\% \Delta \omega = \frac{0.001}{0.1208} \times 100$$

$$= 0.8278145695$$

$$= 0.83\%$$

Percentage uncertainty = 0.83%

(iii) The student used ω and r to calculate the centripetal acceleration of the coin at the instant it started to slide.

Calculate the percentage uncertainty in this centripetal acceleration.

(3)

$$a = r\omega^2$$

$$\% \Delta a = \% \Delta r + (\% \Delta \omega \times 2)$$

$$= 0.6\% + (0.83\% \times 2)$$

$$= 2.26\%$$

Percentage uncertainty = 2.26%



ResultsPlus
Examiner Comments

In Q03(b)(ii), the candidate has shown the correct calculation for the mean, but they have made a calculation error. The response gains credit for mark point 1, although mark point 3 would not be awarded due to this incorrect calculation of the mean. However, the candidate uses neither the half range nor the greatest deviation from the mean in calculating the % uncertainty. Instead, a value of +/- 0.001 is used, and so neither mark point 2, nor mark point 3, can be awarded.

In Q03(b)(iii), the candidate carries out the correct procedure to calculate the % uncertainty in the centripetal acceleration, although the value for the % uncertainty in ω is incorrect. Error carried forward from Q03(b)(ii) is applied, and the response scores all 3 marks.

Question 3 (c)

Very few candidates identified friction as the force that maintained the coin on the turntable. Many candidates thought that centripetal force was a separate force to friction and went on to describe centripetal force as overcoming friction. The most frequent marking point gained was for saying that as $F = mr\omega^2$ then ω decreased as r increased. Many candidates answered the whole question in terms of the acceleration of the coin, with no attempt to link acceleration to the resultant force on the coin.

(c) The student repeated the procedure with different values of r .

Explain how the value of ω at which the coin started to slide varied as r increased.

(3)

As r increased, the value of ω at which the coin started to slide decreased.

$F = mr\omega^2$. Centripetal force, $F =$ friction. (mass, m of coin constant)

~~When the coin slides off,~~ when r increases, the frictional force required to keep the coin stationary increases. There is a maximum frictional force so this will be reached sooner when ω is lower as r increases. (coin slides when this is exceeded)



ResultsPlus
Examiner Comments

This response includes all 3 marking points, and so full marks is awarded.

(c) The student repeated the procedure with different values of r .

Explain how the value of ω at which the coin started to slide varied as r increased.

(3)

$$a = r\omega^2 \text{ is } \frac{a}{r} = \omega^2 \equiv \sqrt{\frac{a}{r}} = \omega \equiv \frac{a}{r} = 2\omega$$

As r and ω are inversely proportionate, as r quadrupled increased in value, the value of ω at which the coin started to slide ~~increased~~ decreased ~~slowly~~ at a rate of $\frac{1}{2}\omega = 2\omega$.



This response is typical of many that were seen. The candidate has started off from an equation for the centripetal acceleration, however, there is no link to the forces that act on the coin and so this response does not explain how the angular velocity at which the coin started to slide would vary with the radius.



Although an equation is often a useful starting point in an explanation, always ensure that you have selected the most appropriate equation to use.

Question 4

This question was often well answered. The most common mistake when using points on the graph was to forget that these were reciprocal values being plotted, so the reciprocal was put in the denominators instead of simply adding when using the lens formula to obtain $1/f$ and then inverting the addition to find f .

Comment on whether the student's data is consistent with his initial determination of the focal length of the lens.

(5)

$$\frac{1}{u} + \frac{1}{v} = \frac{1}{f}$$

$$c = 0.066$$

$$\frac{1}{v} = -\frac{1}{u} + \frac{1}{f}$$

$$c = \frac{1}{f}$$

$$y = mx + c$$

$$0.066 = \frac{1}{f}$$

$$f = \frac{1}{0.066} = \frac{500}{33} = 15.151515\dots \text{ cm}$$

$$15.15 \text{ cm} \approx 15 \text{ cm}$$

The student's data is consistent with his initial determination of the focal length



ResultsPlus
Examiner Comments

In this response, the lens equation has been rearranged to give a comparison with the equation of a straight line. The intercept has been linked to the reciprocal of the focal length, and the value of the intercept has been read off the graph and used to calculate a value for the focal length of the lens. There is a final comment that compares the value determined from the graph with the student's initial determination, and so full marks are awarded.

Question 5 (a)

Candidates quite often had problems interpreting the logarithmic scale and so they used an incorrect μ from the graph. A significant number of candidates gave their answer with an incorrect unit (even though it was given in the question), and so they did not gain mark point 3.

(a) I_0 for the infrared LED is 1.8 W m^{-2} .

Calculate I for the infrared after passing through 1.4 mm of oxygenated blood.

(3)

$$I = I_0 e^{-\mu x}$$

$$\mu = 160 \text{ m}^{-1}$$

$$\ln I = \ln I_0 - \mu x$$

$$x = 1.4 \times 10^{-3}$$

$$\ln I = \ln 1.8 - (160 \times 1.4 \times 10^{-3})$$

$$\ln I = 0.364$$

$$I = 1.44$$

$$I = 1.44 \text{ W m}^{-2}$$



ResultsPlus
Examiner Comments

This response gains all 3 marks. Although the candidate hasn't substituted into the exponential equation, logs have been taken before substituting values and then an inverse log function has been carried out to calculate a value for I that is within range. Correct units are included.

Question 5 (b)

Too many compared deoxygenated blood to oxygenated blood instead of answering the question. Some candidates had difficulty reading the μ values, sometimes using the wrong graph, but most were awarded mark point 1. Many then jumped straight to the answer without giving any acceptable working.

(b) The oximeter determines I/I_0 the fraction of radiation transmitted at each wavelength.

Deduce whether I/I_0 will be smaller for the red or the infrared radiation if the blood is deoxygenated.

$$I = I_0 e^{-\mu x} \therefore \frac{I}{I_0} = e^{-\mu x} \quad (3)$$

(wavelength)

◦ Infrared has a longer λ than visible red radiation. ◦ For deoxygenated blood, μ decreases as λ increases. ◦ Therefore, $e^{-\mu x}$ ($= \frac{I}{I_0}$) will be smaller for red radiation because μ is larger and the negative power is of a larger magnitude.



ResultsPlus
Examiner Comments

This response uses qualitative data from the graph to give a clear deduction, so all 3 marks are awarded.

(b) The oximeter determines I/I_0 the fraction of radiation transmitted at each wavelength.

Deduce whether I/I_0 will be smaller for the red or the infrared radiation if the blood is deoxygenated.

(3)

~~For infrared: $I/I_0 = \frac{1.5}{1.8} = 0.81$~~

For red: $\mu = 400 \text{ m}^{-1}$, $I/I_0 = e^{-400 \times 1.4 \times 10^{-3}} = 0.57$

For infrared: $\mu = 80 \text{ m}^{-1}$, $I/I_0 = e^{-80 \times 1.4 \times 10^{-3}} = 0.89$

$\therefore I/I_0$ is smaller for red radiation as it has a larger value of μ for deoxygenated blood.



ResultsPlus
Examiner Comments

In this response, numerical data is used from the graph to calculate values for I for deoxygenated blood at the two wavelengths. A correct deduction is made, and so all 3 marks are awarded.

Question 5 (c)

Most candidates realised they could calculate the peak wavelength of the emission at 3200K, but not all knew what to do with their answer. Rarely did candidates make an adequate comparison to the wavelength of the infra-red radiation to gain mark point 3.

It is suggested that ambient light could affect the readings produced by the oximeter.

Halogen lamps have a filament temperature of 3200 K.

(c) Deduce whether the light from such a lamp would have a significant effect on the oximeter readings. (3)

$$\lambda_{\max} = \frac{2.898 \times 10^{-3}}{T}$$
$$= \frac{2.898 \times 10^{-3}}{3200}$$
$$= 9.06 \times 10^{-7} \text{ m}$$
$$= 906 \text{ nm}$$

∴ the lamp won't have a significant effect on the readings as μ for 906nm is similar to μ for 950nm

(Total for Question 5 = 9 marks)



Although a correct calculation has been carried out, the deduction made is invalid, and so the response only gains credit for mark point 1 and mark point 2. The candidate has realised that the wavelength is similar to that of the infra-red radiation, but concludes that this will not have a significant effect as the values of μ for these two wavelength will be similar.

It is suggested that ambient light could affect the readings produced by the oximeter.

Halogen lamps have a filament temperature of 3200 K.

(c) Deduce whether the light from such a lamp would have a significant effect on the oximeter readings.

(3)

$$\lambda_{\max} T = 2.898 \times 10^{-3}$$

$$\lambda_{\max} = \frac{2.898 \times 10^{-3}}{3200 \text{ K}} = 9.05625 \times 10^{-7} \text{ m}$$
$$= 905.625 \text{ nm}$$

Which will interfere with light from the infrared LED as its of similar wavelength so it will have a significant effect on the readings.



ResultsPlus
Examiner Comments

A correct calculation and associated deduction, so this response gains all 3 marks.

Question 6 (a) (iii)

This question was not well answered. Many candidates seemed not to understand that the HST was effectively in a bound state system, so moving it further away from the Earth was bringing the gravitational potential energy closer to its maximum of zero. Nor did many candidates use the idea that since $E_{\text{grav}} \propto 1/r$ the satellite would orbit at a greater height. In general, even when candidates had some correct ideas they often failed to back their ideas up with correct equations.

(iii) A student suggests that giving HST more energy than that required in (ii) would result in the satellite orbiting at a greater height and with a greater speed.

Assess the validity of the student's suggestion.



More energy would result in it orbiting at a greater height⁽⁴⁾. This is because it would have more kinetic energy to transfer into gravitational potential energy. Thus since $V = -\frac{Gm}{r}$, increasing r makes V less negative, so this is true. However, the velocity of the HST would actually decrease due to this increase in orbit height. Since $r = \frac{G \times M_{\text{earth}}}{v^2}$, increasing ' r ' would decrease ' v '. This is because the Earth would exert a weaker force on the HST at a greater distance, causing a reduced centripetal acceleration and thus a lower tangential velocity.



ResultsPlus
Examiner Comments

Although the points are made in a different order from the mark scheme, this response says enough for all 4 marks to be awarded.

Question 6 (a) (i) - (ii)

In Q06(a)(i) most candidates could derive the formula for orbital velocity correctly, with a significant number of candidates managing to calculate the orbit radius of the HST and then subtract the radius of the Earth from this, in order to find the height above the Earth's surface.

In part Q06(a)(ii) hardly any understood the difference between gravitational potential and gravitational potential energy. Most candidates just used the approximate gravitational potential energy expression ($mg\Delta h$), which is only appropriate for situations where g remains constant.

6 In 1990, the Hubble Space Telescope (HST) was launched into a low Earth orbit above the Earth's atmosphere.

(a) HST orbits the Earth in a circular orbit with a speed of 7.59 km s^{-1} .

mass of Earth = $5.97 \times 10^{24} \text{ kg}$

radius of Earth = $6.37 \times 10^6 \text{ m}$

(i) Show that the height of HST above the surface of the Earth is about $6 \times 10^5 \text{ m}$.

(3)

$$F = \frac{mv^2}{r} \quad , \quad F = \frac{GMm}{r^2}$$

$$\therefore v^2 r = GM \quad , \quad r = \frac{GM}{v^2}$$

$$r = (6.41 \times 10^6) - (6.37 \times 10^6) = 5.4 \times 10^5 \text{ m}$$

(ii) Calculate the increase in the gravitational potential energy as HST is raised, from its initial position at the Earth's surface, to its orbital height.

mass of HST = $11\,600 \text{ kg}$

(2)

$$E_{\text{grav}} = -\frac{GMm}{r} \quad , \quad \Delta E_{\text{grav}} = E_{\text{final}} - E_{\text{initial}}$$

$$\Delta E = \left(\frac{-6.67 \times 10^{-11} \times 11600 \times 5.97 \times 10^{24}}{6.41 \times 10^6} \right) - \left(\frac{-6.67 \times 10^{-11} \times 11600 \times 5.97 \times 10^{24}}{6.37 \times 10^6} \right)$$

$$\Delta E = 5.67 \times 10^{10} \text{ J}$$

Increase in gravitational potential energy = $5.67 \times 10^{10} \text{ J}$



An example of a correct calculation in both parts, so full marks are awarded here.

- 6 In 1990, the Hubble Space Telescope (HST) was launched into a low Earth orbit above the Earth's atmosphere.

(a) HST orbits the Earth in a circular orbit with a speed of 7.59 km s^{-1} .

mass of Earth = $5.97 \times 10^{24} \text{ kg}$

radius of Earth = $6.37 \times 10^6 \text{ m}$

(i) Show that the height of HST above the surface of the Earth is about $6 \times 10^5 \text{ m}$.

(3)

$$g = \frac{Gm}{r^2}$$

$$\frac{mv^2}{r} = \frac{GmM}{r^2}$$

~~$$g = \frac{Gm}{r^2} = \frac{(6.67 \times 10^{-11})(5.97 \times 10^{24})}{(6.37 \times 10^6)^2}$$~~

$$v^2 r = Gm$$

$$r = \frac{Gm}{v^2}$$

$$(6.67 \times 10^{-11})(6.37 \times 10^6)$$

$$\frac{(6.67 \times 10^{-11})(6.37 \times 10^6)}{(7590)^2} = 6912205 - (6.37 \times 10^6)$$

$$= 542205 \approx 5.4 \times 10^5 \text{ m} \approx 6 \times 10^5 \text{ m}$$

(ii) Calculate the increase in the gravitational potential energy as HST is raised, from its initial position at the Earth's surface, to its orbital height.

mass of HST = $11\,600 \text{ kg}$

(2)

$$V_{\text{grav}} = \frac{-Gm}{r} = \frac{-(6.67 \times 10^{-11})(11600)}{6 \times 10^5}$$

$$= 1.3 \times 10^{-12} \text{ Nm kg}^{-1}$$

Increase in gravitational potential energy = $1.3 \times 10^{-12} \text{ Nm kg}^{-1}$



Q06(a)(i) is correct and gains all 3 marks. However, in Q06(a)(ii) the candidate has calculated the gravitational potential at a distance from the surface of the Earth, so this part scores zero.

6 In 1990, the Hubble Space Telescope (HST) was launched into a low Earth orbit above the Earth's atmosphere.

(a) HST orbits the Earth in a circular orbit with a speed of 7.59 km s^{-1} .

mass of Earth = $5.97 \times 10^{24} \text{ kg}$

radius of Earth = $6.37 \times 10^6 \text{ m}$

$$F = \frac{mv^2}{r}$$

$$F = \frac{GM_1M_2}{r^2}$$

(i) Show that the height of HST above the surface of the Earth is about $6 \times 10^5 \text{ m}$.

$$\frac{mv^2}{r} = \frac{GM_1M_2}{r^2} \rightarrow r = \frac{GM}{v^2} \quad (3)$$

$$r = \frac{6.67 \times 10^{-11} \times 5.97 \times 10^{24}}{(7.59 \times 10^3)^2} = 6.91 \times 10^6 \text{ m}$$

$$(6.91 \times 10^6) - (6.37 \times 10^6) = 5.42 \times 10^5 \text{ m}$$

$$\approx 6 \times 10^5 \text{ m}$$

(ii) Calculate the increase in the gravitational potential energy as HST is raised, from its initial position at the Earth's surface, to its orbital height.

mass of HST = $11\,600 \text{ kg}$

$$E_{\text{grav}} = \frac{GMm}{r} \quad (2)$$

~~$$= \frac{6.67 \times 10^{-11} \times 5.97 \times 10^{24}}{6.37 \times 10^6}$$~~

~~$$= 7.35 \times 10^8 \text{ J}$$~~

$$\text{GPE} = mgh$$

$$= 11600 \times 9.81 \times 5.42 \times 10^5$$

$$\text{Increase in gravitational potential energy} = \frac{6.17 \times 10^8 \text{ J}}{6.17 \times 10^{10} \text{ J}}$$



The response for Q06(a)(i) is correct, and 3 marks are awarded. In Q06(a)(ii) the candidate has used the simple expression for changes in gravitational potential energy. This expression is only suitable in situations where g remains constant and so no marks can be awarded for the response to this part.



Ensure that any equations you select are valid for the situation given in the question.

Question 6 (b)

Few candidates referred to a specific wavelength or region of the spectrum. As the question clearly says 'shown by this graph', the response must take data from the graph. Those that interpreted the graph correctly realised that the infra-red wavelength range between 10^{-5} and 10^{-3} m was absorbed by the atmosphere, so having the HST above the atmosphere meant that these wavelengths would be detected. Some thought that the HST would transmit certain wavelengths.

Question 6 (c)

On the whole this question was answered well. The awkward units were generally handled well, and many candidates were familiar with the calculation. Some candidates were caught out by the non-zero y intercept in their gradient calculations, effectively choosing one point, not the gradient, for their calculation. A number of responses stopped after a calculation of the gradient; these candidates were assuming that the gradient was the age. Although not required by the question, many candidates converted their answer to years.

(c) High resolution images from HST allow astronomers to make detailed measurements of very distant galaxies. The graph shows how the recessional velocities of distant galaxies depend on their distance from Earth.

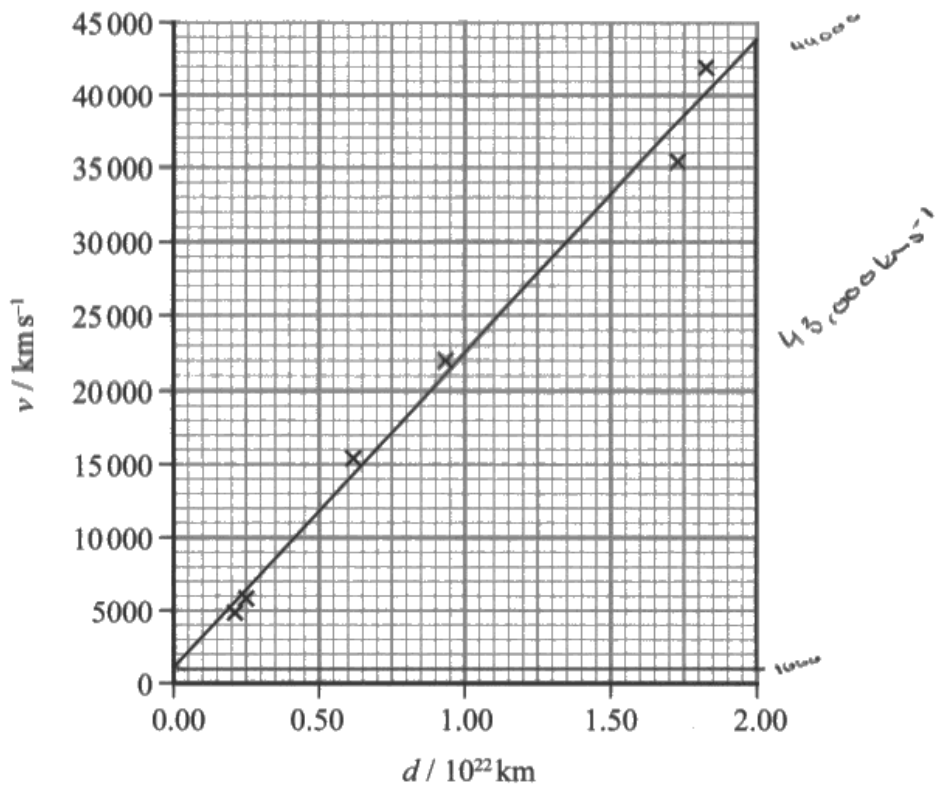

Determine an age for the universe.

$$2 \times 10^{22} \text{ km}$$

(3)

$$v = H_0 d$$

$$H_0 = \frac{v}{d}$$

$$= \frac{43,000 \text{ km s}^{-1}}{2 \times 10^{22} \text{ km}}$$

$$\frac{1}{2.15 \times 10^{-18} \text{ s}} = 4.7 \times 10^{17}$$

31557600 s in 1 year

$$H_0 = 2.15 \times 10^{-18} \text{ s}^{-1}$$

$$\frac{4.7 \times 10^{17}}{31557600}$$

$$\text{Age for the universe} = 1.5 \times 10^{10} \text{ years}$$



This response scores all 3 marks. The gradient of the graph is determined, a value for the reciprocal of the gradient is identified as the age of the universe, and the final answer is correct. The conversion of the age of the universe from a time in seconds to a time in years is unnecessary.



Don't waste time carrying out arithmetic manipulations that are not required by the question.

Question 7 (a) (i)

This question asks for an explanation of the procedure, but few responses did more than describe it. However, a good number of candidates achieved the 4 marks for describing how the time period would be measured. Most candidates remembered to repeat and take a mean value of their time for n oscillations. Some candidates omitted to state a minimum/suitable value for n . Fiducial marks were commonly mentioned, but where to put the mark was a bit more problematic. The better answers said the marker should be placed at the equilibrium position of the trolley and the oscillations timed from there. Few candidates explained that increasing the time reduced the uncertainty in it and very rarely, that the trolley was moving fastest at the equilibrium position so the uncertainty in starting and stopping the stopwatch would be reduced. Some candidates mentioned the marker being placed at the equilibrium position but then proceeded to say that the stopwatch was started from the point of release of the trolley. Some placed the marker on the trolley.

Given the large number of responses that omitted any kind of explanation for the procedure, candidates did not appear to understand why a large number of oscillations is timed, or why the timing should be done from the centre of the oscillation. Or perhaps candidates mistook the command word 'explain' for 'describe'.

- 7 A trolley is attached to the ends of two springs as shown. When displaced from its equilibrium position, the trolley moves with simple harmonic motion.

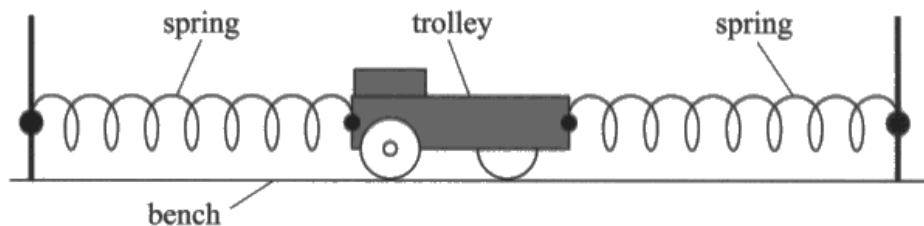

(a) A student has a stopwatch and metre rule available.

- (i) Explain the procedure that the student should follow to make an accurate determination of the time period T of the trolley.

(6)

- Place a fiducial marker ~~at the~~ on the trolley bench at the equilibrium position.
- Displace the trolley for a known amount measured by the metre rule placed parallel to the trolley.
- Release the trolley and start the stopwatch, timing for 10 or more complete oscillations.
- Repeat this for at least 3 attempts.
- Calculate an average of the time taken ~~to~~ for 10 or more oscillations to reduce effect of random error.
- Calculate a mean T by dividing the previous average for 10 or more oscillations by the number of oscillations.



ResultsPlus
Examiner Comments

This response is typical of responses in which a 'describe' rather than an 'explain' answer was given to the question.



Read the command sentence carefully to ensure that you are giving an appropriate response.

- 7 A trolley is attached to the ends of two springs as shown. When displaced from its equilibrium position, the trolley moves with simple harmonic motion.

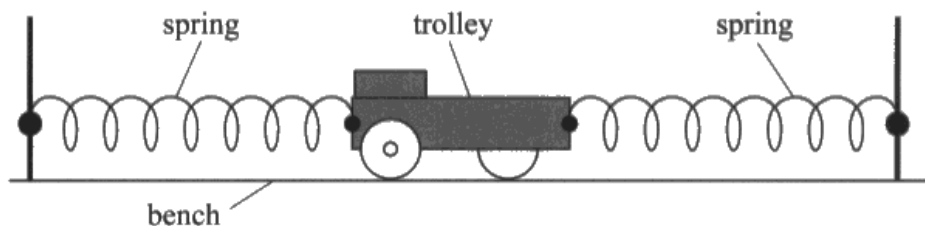

- (a) A student has a stopwatch and metre rule available.
(i) Explain the procedure that the student should follow to make an accurate determination of the time period T of the trolley.

(6)

→ Measure T for multiple oscillations and divide it by number of oscillations to get an accurate answer. % uncertainty due to human reaction could be smaller.

→ Mark a equilibrium point using a ~~fiducial~~ fiducial marker. Always ~~measure~~ take measurements from equilibrium position as it is the fastest here, so reduce uncertainty.

View parallel to marker to reduce parallax error.

→ Take measurements after at least one oscillation, so that the measurements won't be influenced by initial force.

→ Take repeats and calculate a mean to discard anomalies and reduce random error.



All elements of the procedure are described and linked to reasons, so full marks are awarded here.

Question 7 (a) (ii)

Few candidates fully explained that the amplitude needed to be measured from the equilibrium position to the position of maximum displacement. Most scored the other two marks.

Those candidates who just said 'measure the amplitude' were not awarded mark point 2, as this was not considered to be sufficiently detailed. Candidates need to be very careful in their use of words with a particular meaning in physics if they are to gain marks. Many left a $\sin \omega t$ in the calculation of v without saying that $\sin \omega t = 1$ for maximum speed.

Question 7 (b)

Many candidates realised that reaction time was eliminated using a sensor and data logger. However, the phrase 'human error' was insufficient for credit to be given. Reasons such as being able to plot a graph were not credited as they were irrelevant to the experiment.

Question 7 (c)

The expression $v_{\max} = \omega A$ was usually written, but rarely was it clarified that ω was constant. The fact that if A doubled, then v_{\max} doubled was quite often stated, and then the correct conclusion about the change of KE was given.

(c) The student displaces the trolley a greater distance from the equilibrium position, so the amplitude of oscillation is doubled. The trolley still moves with simple harmonic motion.

Explain how the maximum kinetic energy of the trolley will change.

(3)

Since the amplitude (A) is doubled, $v_{\max} = 2A\omega$

ω is constant so v_{\max} doubles.

$E_k = \frac{1}{2}mv^2$ since v_{\max} doubles, max kinetic energy

must quadruple ($\times 4$)



ResultsPlus
Examiner Comments

All three marking points are seen in this response, so 3 marks are awarded.



When using an equation to explain how a quantity will change, be sure to refer to all of the variables in the equation.

Question 8 (a)

On the whole this question was well answered. Most candidates used the method shown in the mark scheme, although some candidates confused the different times and distances given in the question stem and ended up with average speeds or incorrect results.

There were quite a few who used the equation $s = vt - \frac{1}{2}at^2$ to determine the deceleration during the 32.5m when the stone is brought to rest and then correctly used $v = u + at$ to obtain a value for u , and ultimately the right answer. Some candidates sketched a velocity time graph to aid their understanding. Quite a few candidates correctly used $F = ma$ and $W = Fs$, even though there was a lot more calculating to do that way.

- 8 In the sport of curling, two teams of 'curlers' take turns sliding polished granite stones across an ice surface towards a circular target marked on the ice.

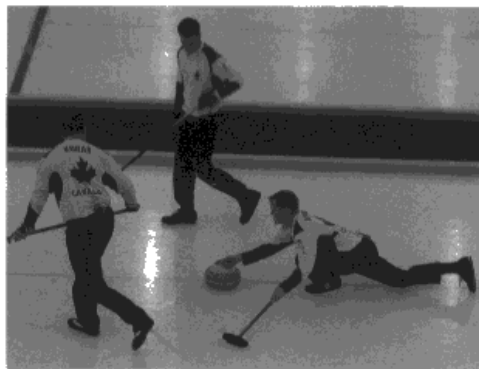

commons.wikimedia.org

- (a) A stone of mass 19.6kg is accelerated uniformly for 1.25 s before being released by a curler. The stone then decelerates uniformly to rest, travelling 32.5 m in a time of 17.5 s.

Calculate the average useful power developed by the curler in accelerating the stone.

(4)

$$\begin{array}{l}
 s \ 32.5 \\
 u \ u \\
 v \ 0 \\
 a \ a \\
 t \ 17.5
 \end{array}
 \quad
 s = \frac{(u+v)t}{2}
 \quad
 32.5 \times 2 = (u+0) 17.5$$

$$\frac{65}{17.5} = u$$

$$\frac{26}{7} = u$$

$$\Delta W = FAS \quad P = \frac{W}{t} = \frac{FAS}{t} = \frac{maAs}{t}$$

$$\begin{array}{l}
 s \\
 v \ 0 \\
 v \ \frac{26}{7} \\
 a \ a \\
 t \ 1.25
 \end{array}
 \quad
 v = u + at$$

$$\frac{26}{7} = 0 + a(1.25)$$

$$a = 2.97 \text{ ms}^{-2}$$

$$s = ut + \frac{1}{2}at^2 \quad s = \frac{1}{2}(2.97)(1.25)^2$$

$$P = \frac{19.6 \times 2.97 \times 2.321}{1.25}$$

$$P = 108.14 \text{ W}$$

$$\text{Average power} = 108.14 \text{ W}$$

The calculation is carried out correctly and all the working clearly shown. This response gains 4 marks.

- 8 In the sport of curling, two teams of 'curlers' take turns sliding polished granite stones across an ice surface towards a circular target marked on the ice.



commons.wikimedia.org

- (a) A stone of mass 19.6 kg is accelerated uniformly for 1.25 s before being released by a curler. The stone then decelerates uniformly to rest, travelling 32.5 m in a time of 17.5 s.

Calculate the average useful power developed by the curler in accelerating the stone.

(4)

$$\begin{aligned} 32.5 / 0.5 \times 17.5^2 &= 0.2 \text{ m s}^{-2} \times 19.6 = 4.16 \text{ N} \times 32.5 \\ &= 135.2 \text{ J} / 1.25 \\ &= 108.16 \text{ W} \end{aligned}$$

Average power = 108.16 W



The calculation is correct and gains all 4 marks. However, the working is not clearly shown and should the final answer have been incorrect, it might have been difficult to award method marks.



Show your working clearly in all calculations.

Question 8 (b)

This question required candidates to construct a coherent and logically structured answer with linkages between the physics points relevant to the situation. The context in this question is relatively novel, but the physics is reasonably well known by candidates, and so this question was usually well answered. Most candidates identified conservation of momentum, but some referred to conservation of energy rather than kinetic energy in an elastic collision. The better answers went on to say that the momentum of A was transferred to the momentum of B and that stone A would be at rest after the collision, so the KE of stone A had been transferred to stone B. It was less common for candidates to say that external forces could be neglected. A minority of candidates thought that this question was about Newton's laws rather than conservation laws. Careful reading of the question should have avoided this error being made.

The collision is elastic. Just before the collision stone A has a velocity v . After the collision stone B moves off with velocity v .

Discuss how the relevant conservation laws apply to this collision.

(6)

Momentum is conserved in all collisions so

$$m_A u_A + m_B u_B = P_{\text{before}} = P_{\text{after}}$$

$$\therefore m_A u_A + m_B u_B = m_A v_A + m_B v_B$$

$$m v + m(0) = m(0) + m v$$

for momentum to be conserved, stone A ^{must} be stationary _{after the collision} as $m v = m v + m(0)$.

As the collision is elastic kinetic energy is also conserved. \therefore KE before = KE after

$$\frac{1}{2} m_B (v_0)^2 + \frac{1}{2} m_A (v_A)^2 = \frac{1}{2} (m_A) (v_A)^2 + \frac{1}{2} (m_B) (v_B)^2$$

$$\frac{1}{2} m(0)^2 + \frac{1}{2} m v^2 = \frac{1}{2} m(0)^2 + \frac{1}{2} m v^2$$

$$\therefore \frac{1}{2} m v^2 = \frac{1}{2} m v^2 \quad \text{SO KE IS CONSERVED.}$$



This response omits any reference to external forces, although all the other indicative content points are included. The use of equations to communicate that all of the kinetic energy of stone A must have been transferred to stone B is acceptable and so this response has 3 marks for indicative content and both linkage marks, giving 5 marks in total.



If there are limiting conditions for physical laws, be sure to state them in your explanation.

Question 8 (c)

This question was quite well answered although a significant number of responses just mentioned the fact that friction would be reduced without saying why. There were a few references to the 'forward force' on the stone increasing, rather than a reduction in the decelerating force.

Question 9 (a)

This question was mostly well answered, with candidates correctly comparing the logarithmic expansion of the given equation with the equation of a straight line. However, in some responses it was unclear what y , m , x and c linked to in the equation $y = mx + c$.

- 9 The Beaufort scale is used to describe wind intensity. On this scale the average wind speed v increases with the Beaufort scale value B .

The relationship between v and B is given by

$$v = kB^p$$

where k and p are constants.

- (a) Explain why a graph of $\log v$ against $\log B$ should give a straight line.

(2)

$$v = kB^p$$

$$y = \log v$$

$$\log v = \log k + p \log B$$

$$c = \log k$$

$$y = c + mx$$

$$m = p$$

$$x = \log B$$



ResultsPlus
Examiner Comments

The log expansion is correct and the link to the equation of a straight line is clear. This response gains full marks.

Question 9 (b)

In Q09(a)(i) few candidates completed the table with values to 3 significant figures. Very few candidates gave the correct y-axis labels [$\log(v/\text{m s}^{-1})$]. Scales were usually correctly chosen but some candidates used multiples of 3 or 4. Most points were plotted well and the line of best fit was usually well drawn.

In Q09(a)(ii) the gradient was usually calculated correctly using a large triangle to find the value of p . The value of the intercept commonly missed the unit of m s^{-1} .

(b) The table gives some values of v and corresponding values of B .

(all to 3sf)

$v / \text{m s}^{-1}$	B	$\log(v/\text{m s}^{-1})$	$\log(B)$
2.00	1	0.301	0.00
10.0	3	1.00	0.477
21.5	5	1.33	0.699
36.0	7	1.56	0.845
50.5	9	1.70	0.954
68.0	11	1.83	1.04

- (i) Plot a graph of $\log v$ against $\log B$ on the grid opposite.
Use the columns provided to show any processed data.

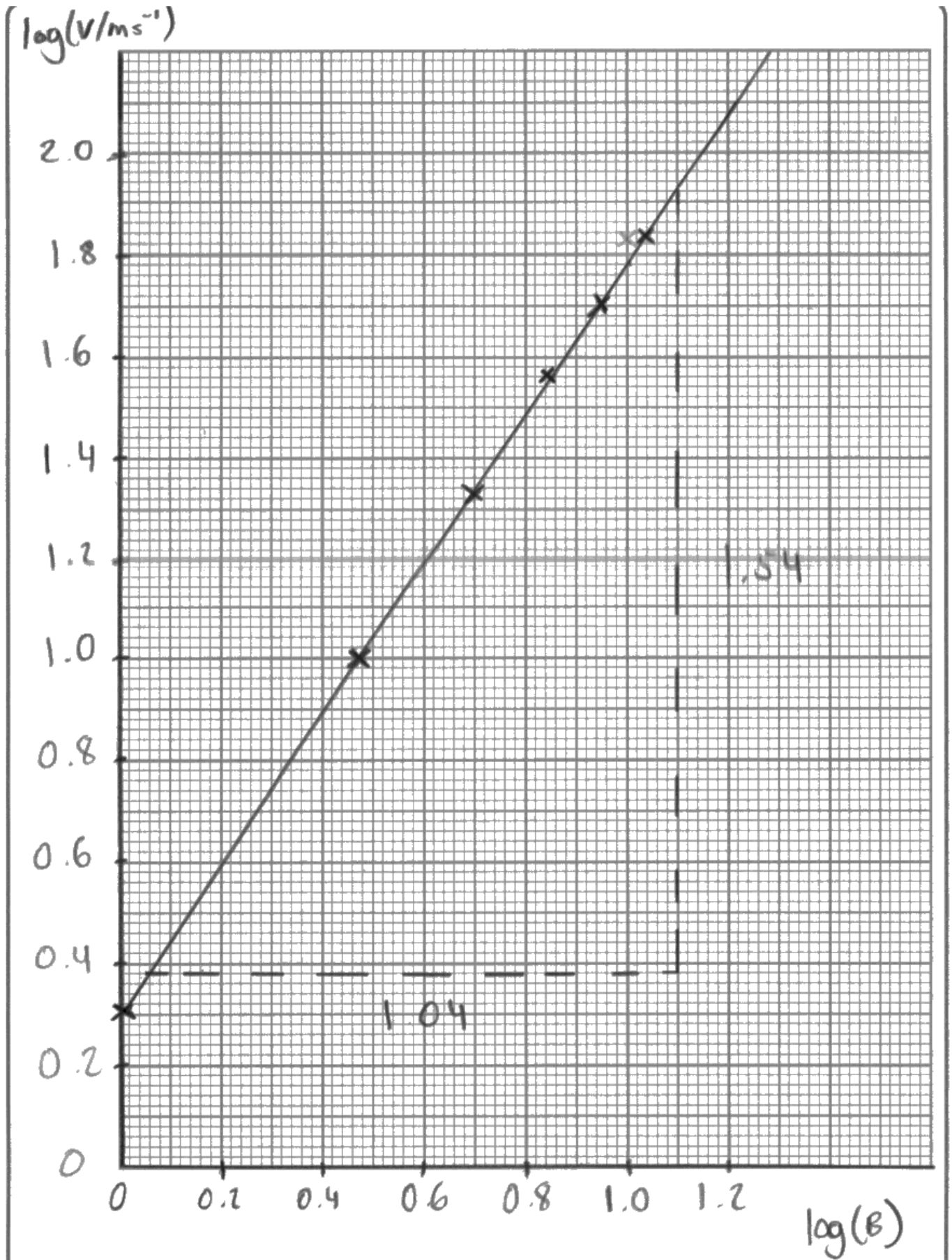

(ii) Determine the values of p and k .

(3)

$$\log(k) = y \text{ intercept}$$

$$p = \text{gradient}$$

$$\log k = 0.301$$

$$p = \frac{1.54}{1.04}$$

$$k = 2.00 \text{ m s}^{-1}$$

$$p = 1.48$$

$$p = 1.48$$

$$k = 2.00 \text{ m s}^{-1}$$



ResultsPlus
Examiner Comments

This response scores full marks for both parts of the question. Note the labelling on the y-axis. In this response it is clear that the candidate has divided by the units of v before taking logs. This marking point was often not awarded.

Question 10 (a)

Although this was a well answered question, some candidates were unable to convert cm^2 to m^2 correctly.

Candidates introduced a random factor of 10 later in the calculation to obtain an answer in the correct range.

There were responses where the cross-sectional area of 0.85 cm^2 was misinterpreted as an area of $0.85 \text{ cm} \times 0.85 \text{ cm}$.

10 Seat belts are being tested by a car manufacturer. In the test, a car moving at a steady speed of 28 m s^{-1} collides with a wall and stops.

A crash-test dummy in the driving seat is wearing a seat belt made from polyester webbing. The seat belt has a cross-sectional area of 0.85 cm^2 and a total length of 2.0 m . A student suggests that in the collision the seat belt absorbs all the kinetic energy of the dummy.

(a) Show that the energy per unit volume that would have to be absorbed by the seat belt is about $2 \times 10^8 \text{ J m}^{-3}$.

mass of dummy = 75 kg

(3)

$$KE = \frac{1}{2} m v^2$$

$$KE = \frac{1}{2} \times 75 \times (28)^2 = 29400 \text{ J}$$

OR ~~the~~ cross sectional area = 0.85 cm^2

$$\cancel{0.85} \times (0.85 \times 10^{-2 \times 2}) \times 2$$

$$\text{Area} = 1.7 \times 10^{-4} \text{ m}^2$$

$$29400 \div 1.7 \times 10^{-4} \text{ m}^2 = 1.729 \times 10^8 \text{ J m}^{-3} \approx 2 \times 10^8 \text{ J m}^{-3}$$



ResultsPlus
Examiner Comments

In this response the cross-sectional area is correctly converted into SI units. This value is multiplied by the length of the seat belt to calculate the volume (although it is labelled 'area' by the candidate). The final answer is correct and given to more than 1 significant figure and so all 3 marks are awarded.



In a 'show that' question you must give your final answer to at least one more significant figure than the value quoted in the question.

Question 10 (b) (i)

The factor of a half was missing from a lot of responses, as many candidates started from the standpoint that the area under the graph was equal to *stress* x *strain*. Some candidates thought that this required a calculation, and some tried using a method using units. Many candidates who achieved mark point 1 did not make it clear in their subsequent explanation that the stored elastic energy was $\frac{1}{2} F\Delta x$ and therefore, were not awarded mark point 2.

(i) Show that the area under the graph represents the energy stored per unit volume in the seat belt.

$$\sigma = \frac{F}{A}, \quad \epsilon = \frac{\Delta x}{x} \quad (2)$$

area under graph = $\frac{1}{2} \times \sigma \times \epsilon$

$$\text{area} = \frac{1}{2} \times \frac{F}{A} \times \frac{\Delta x}{x}$$
$$\text{area} = \frac{1}{2} \times \frac{F\Delta x}{V}$$
$$\Delta E_{el} = \frac{1}{2} F\Delta x$$
$$\therefore \text{area} = \frac{\Delta E_{el}}{V}$$

This response works through the problem methodically and scores both marks.

(i) Show that the area under the graph represents the energy stored per unit volume in the seat belt.

$$\frac{\sigma}{\epsilon} = \frac{\frac{F}{A}}{\frac{\Delta x}{x}} = \frac{\frac{F}{A} \cdot x}{\Delta x} = \frac{Fx}{A \Delta x} \quad (2)$$

$$= \frac{\text{kg m} \cdot \text{s}^{-2} \cdot \text{m}}{\text{m}^2 \cdot \text{m}} = \frac{\text{kg m}^2 \cdot \text{s}^{-2}}{\text{m}^3} = \frac{\text{kg s}^{-2}}{\text{m}}$$

$\frac{\text{J}}{\text{m}^3}$



ResultsPlus
Examiner Comments

Many candidates used a unit analysis to show that the area under the graph represents the energy stored per unit volume. This was worth 1 mark for showing that the area is dimensionally the same as an energy per unit volume.

Question 10 (b) (ii)

Candidates who chose the straight line portion of the graph usually went on to correctly calculate the area under the graph up to a strain of 0.075, and then equate the value to the energy stored per unit volume. However, many candidates were not specific with their comparison statement, or they compared energy with energy per unit volume. Power of 10 errors were seen in some responses. Sometimes candidates attempted to calculate the whole area under the graph.

(b) The graph shows how stress varies with strain for the seat belt.

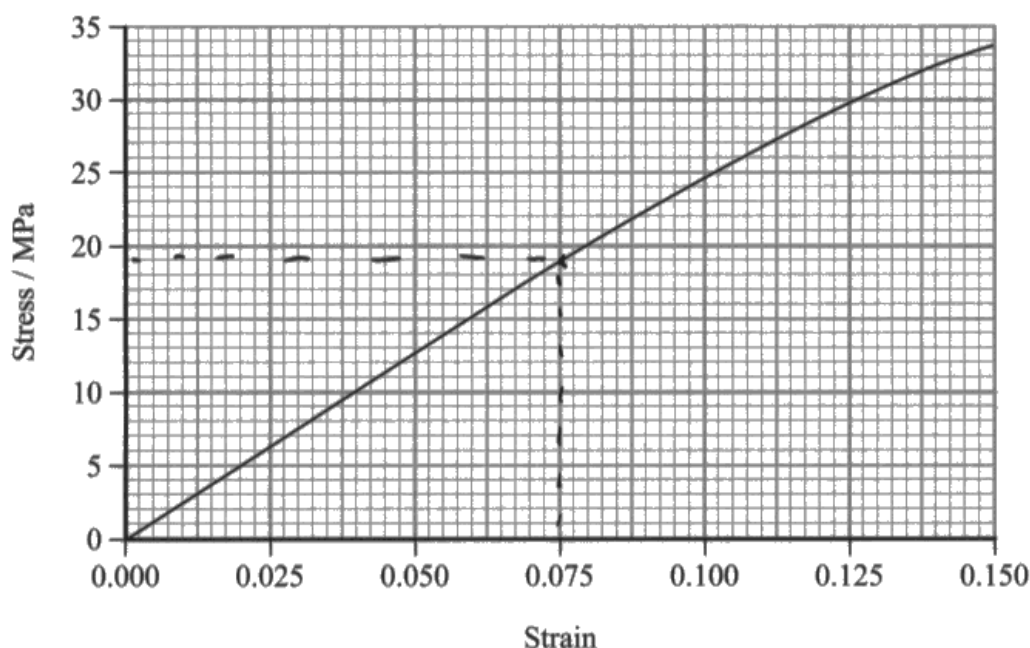

(ii) Use the graph to determine whether the seat belt absorbs all the kinetic energy of the dummy from part (a).

In this collision, the maximum strain of the seat belt is 0.075

(3)

$$\frac{1}{2} \times 19 \times 10^6 \text{ Pa} \times 0.075 = 712500 = 7.1 \times 10^5 \text{ Jm}^{-3}$$

$7.1 \times 10^5 \text{ Jm}^{-3} < 1.7 \times 10^8 \text{ Jm}^{-3}$ ~~therefore~~ \therefore No it does not absorb all of the energy.



In this response it is clear that only the area up to 0.075 has been calculated. There is a comparison between two like quantities and a valid conclusion is made.

Question 11 (a) (iii)

Many candidates had a good understanding of the experiment and what would be required. The most common responses were to stir the water, use a digital thermometer, put the thermometer close to the tube and take readings in line with the scale. Some candidates referred to the use of a data logger, but omitted to state the temperature measuring device. Many responses included reference to repeats and averaging, or thought it was to the water transferring energy to the surroundings.

Question 11 (a) (i) - (ii)

In Q11(a)(i), a common error was to state that there was an inconsistent number of significant figures. At this level, candidates should be aware that raw data should be quoted to a number of decimal places appropriate to the resolution of the measuring instrument being used. It was common to see responses that identified no evidence of repeats or that more readings were needed. It seemed to be a widely held view that results should be taken at equal intervals, although the real issues with the students' results is that the range was too small, or that there weren't enough readings between 24 °C and 60 °C.

In Q11(a)(ii), many candidates did not fully develop their sources and could only score 1 out of the two marks for each pair. Such responses did not link the source of error with the cause, so candidates had missed the need for explanation from the command sentence in the question. The usual mark awarded was that there could be a parallax error, but candidates often didn't say that the temperature/length may be read incorrectly. Another fairly common response was that the trapped air may not have been at the temperature of the water, but fewer said that this was because the temperature of the water may not have been uniform. Occasionally there was a comment that the bore of the tube was not uniform which meant that the volume of trapped air may not be proportional to the length of the air column.

11 A student investigated how the volume of a fixed mass of air varies with the temperature of the air. She used the apparatus shown.

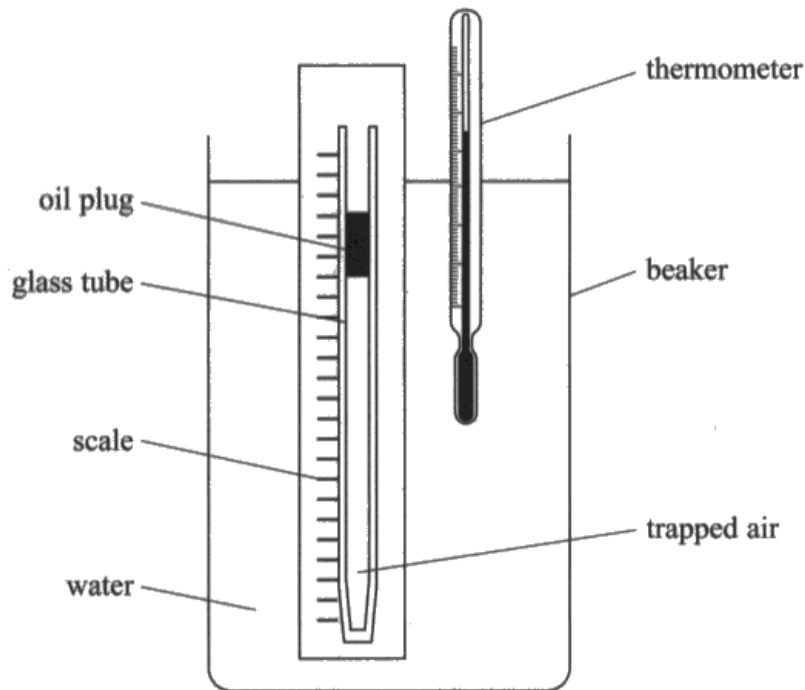

A glass tube was sealed at one end. A plug of oil trapped a length l of air in the tube. The water in the beaker was heated to a temperature θ . The corresponding value of l was measured. This was repeated for a range of temperatures.

The thermometer had a resolution of 0.5°C . The scale had mm divisions.

The student's results are shown in the table.

$\theta / ^\circ\text{C}$	l / cm
24	8.8
60	9.8
78.5	10.3
95.5	10.9

(a) (i) Criticise the student's results.

(3)
 Inconsistent number of ~~significant~~ decimal places used for temperature measured
 as gone from 60°C (to 0.1°C) to 78.5°C (to 0.1°C)
 There are only a few (4) sets of results collected, with no evidence of
 multiple tests and an average being taken.

(ii) Explain two possible sources of error in this investigation.

The water in the beaker may not be evenly / uniformly⁽⁴⁾ heated, so the temperature of the glass tube may not be the same as what the thermometer states ~~it~~ / shows.

When reading the temperature off of the thermometer, ~~if~~ you can introduce the systematic error of parallax error by not reading the thermometer from a level position (ie looking down/up at it), giving a human a wrong ~~reading~~ or different reading to what it actually shows.



ResultsPlus
Examiner Comments

In this response full marks are scored in both parts of the question.

Question 11 (b) (i)

Absolute zero was well known; also that it was the temperature at which the atoms/molecules had zero KE. A significant number of candidates used 'particles' instead of atoms/molecules, which was not accepted. Few said that the volume occupied by the air would be zero at this temperature.

(b) The student plotted a graph of l against θ as shown.

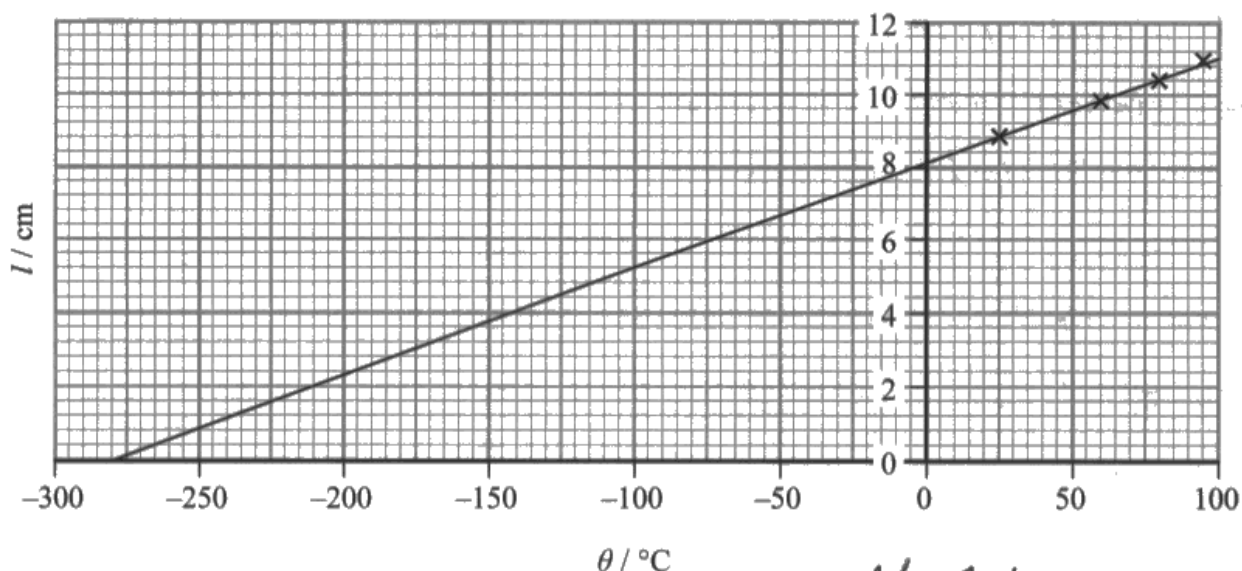

Absolute zero.

(i) Explain the significance of the intercept on the x-axis.

(3)

The ~~intercept~~ x intercept shows absolute zero, where gas molecules don't have ~~energy~~ any internal energy; average KE of particles = 0 J. Shows that at Absolute zero, the gas has no volume.



ResultsPlus
Examiner Comments

This response includes enough detail for all three marks to be awarded.

(b) The student plotted a graph of l against θ as shown.

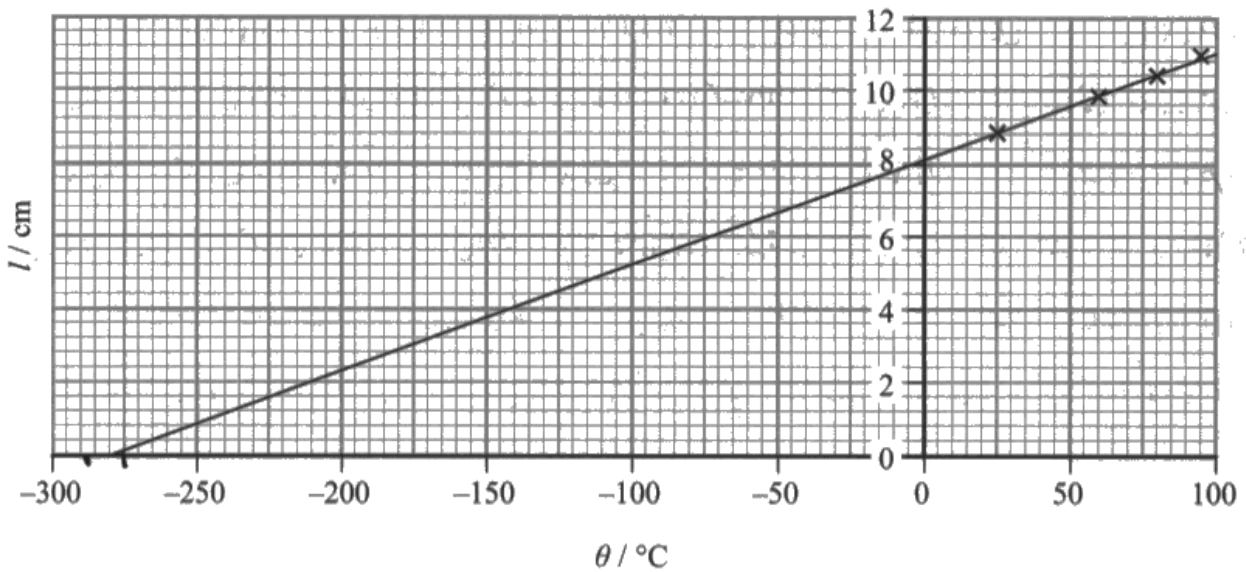

(i) Explain the significance of the intercept on the x-axis.

(3)

As the x-axis is meant to be -273°C which is absolute zero or zero in Kelvin it proves that only a -273°C can the volume or pressure be zero due to $pV = nKT$. As this x-axis is slightly off there can be assumed there is a small error in this experiment.



Although this candidate has slightly misinterpreted the question, they still say enough to gain mark point 1 and mark point 2. Since there is no reference to absolute zero being the lowest attainable temperature mark point 3 cannot be awarded, and so the response is only awarded 2 marks.



Be sure to give as complete a response as possible.

Question 11 (b) (ii)

On the whole this question was poorly answered. Many candidates did not link the student's conclusion to the experimental set-up given at the start of the question, and therefore, seemed content to accept that the instruments used were high resolution. In general, there was a tendency for candidates to affirm, rather than contest, the conclusions drawn by the student. The most commonly given answers were that there could be a systematic error or more points were needed, and that the first statement in the conclusion was correct. Fewer said that the instruments used were not high resolution or that there could be extrapolation errors. Some said that the points did lie on a perfect straight line, while others correctly said that there was one that didn't. Many candidates wrote extensively about accuracy and precision, but too many did not understand resolution and thought a high resolution instrument had bigger divisions and so more uncertainty.

- (ii) The student wrote a report of the investigation in her lab book. In the conclusion she wrote:

"In this investigation uncertainties were minimised by selecting measuring instruments with a high resolution. The points lie on a perfect straight line, indicating that the investigation is accurate."

Discuss the student's conclusion.

(4)

The points don't lie exactly on a straight line (eg at 95.5°C) and you can't draw this conclusion reliably from just four results. They need many more points over a wider range, some below 0°C if possible or maybe. Accurate means her results are close to the true value, and you can't draw that conclusion from just having a straight line as there could be a systematic error.

A higher resolution will reduce % uncertainty, however there were lots of other variables that can affect it. The 8.5cm measurement has a % of 1.1% and the temperature at 24°C has a % of 1.0% which is sufficiently low enough.

In this response three valid points are made related to the graph part of the conclusion. The first point related to the resolution is correct, but the candidate doesn't identify the instruments used as being low resolution. However, there is enough for full marks to be awarded.

- (ii) The student wrote a report of the investigation in her lab book. In the conclusion she wrote:

"In this investigation uncertainties were minimised by selecting measuring instruments with a high resolution. The points lie on a perfect straight line, indicating that the investigation is accurate."

Discuss the student's conclusion.

(4)

The instruments (mainly the thermometers) did not have a high resolution and produced larger uncertainties. The number of data points is too low to fully support the line of best fit, however they do lie on a straight line. The °C value for absolute 0 is slightly higher than accepted at around ~~278~~ -278°C meaning a % difference of 1.8% however this can be accounted for in the uncertainties due to the resolution of the instruments.

(Total for Question 11 = 16 marks)

$$\frac{-278 + 273}{273} \times 100$$



In this response it is clearly stated that the resolution of the instruments is not particularly high. Although the candidate does not identify directly that high resolution instruments would have reduced the uncertainties in the investigation, this is implied in their statement that because the instruments did not have a high resolution the uncertainties would be larger. Together with the student's statement on whether there are enough points to support the line of best fit, there is enough in this response for 3 marks to be awarded.

Question 12 (a)

This was another poorly answered question, with few candidates providing a full explanation. Only a minority of candidates said that the speed of impact was the same for both spheres. Mark point 3 was most commonly scored if candidates correctly identified the cube factor, but many failed to show the link between diameter/radius and mass clearly enough to gain mark point 2. A significant minority of candidates did not have the correct formula for the volume of a sphere. Although the formula wasn't required, candidates did need to know that volume is proportional to r^3 . However, many candidates had r^2 in their incorrect formula.

- 12 Impact craters are formed when meteorites strike the surface of a planet. A student investigated some factors that might influence the formation of impact craters. He did this by dropping spheres of modelling clay into a tray of sand.

The diameter of the crater produced by each sphere was measured using vernier calipers as shown.

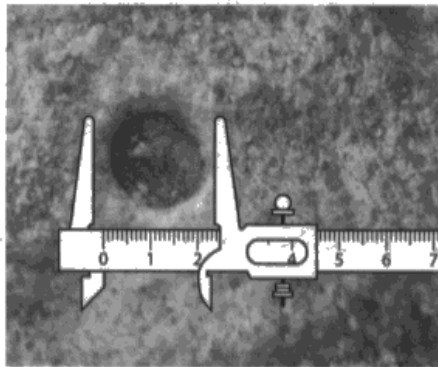

$$m = 2$$

$$\frac{1}{2} \times 2 \times 2g(0.02)$$

$$\frac{1}{2} \times 2 \times 2g(0.04)$$

This process was repeated for spheres of different diameters.

- (a) In one test, the spheres were dropped from the same height.

Determine the factor by which the kinetic energy of the sphere just before impact increases when the sphere diameter is increased from 2.0 cm to 4.0 cm.

(3)

$mgh = \frac{1}{2}mv^2$ If the ^{diameter} height increases the by a factor of 2, the velocity ^{volume increases by a factor of eight} is ~~gravitational potential~~ ^{so the mass of the sphere will increase by a factor of eight} ~~energy of the sphere will double so the kinetic energy will also double. eight and the kinetic energy increases by a factor of eight.~~

$$mgh = \frac{1}{2}mv^2$$

$$D = \frac{M}{\rho} \quad M = \rho V \quad \rho = \frac{M}{V} \quad \rho = \frac{M}{\frac{4}{3}\pi r^3} \quad \rho = \frac{3M}{4\pi r^3}$$

$$8M = 8\rho V \quad \rho = \frac{3M}{4\pi r^3} \quad \rho = \frac{3M}{4\pi (\frac{D}{2})^3} \quad \rho = \frac{3M}{4\pi \frac{D^3}{8}} \quad \rho = \frac{3M \cdot 8}{4\pi D^3} \quad \rho = \frac{6M}{\pi D^3}$$

Factor = 8

Although the response is a little jumbled, the final answer is correct, and there is justification for the factor stated.

- 12 Impact craters are formed when meteorites strike the surface of a planet. A student investigated some factors that might influence the formation of impact craters. He did this by dropping spheres of modelling clay into a tray of sand.

The diameter of the crater produced by each sphere was measured using vernier calipers as shown.

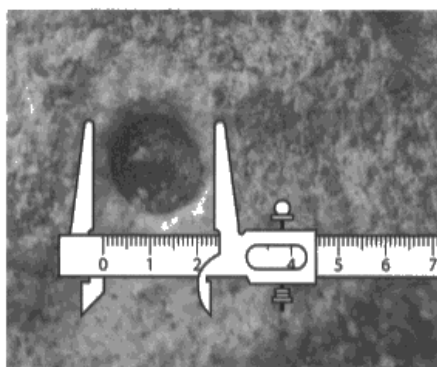

This process was repeated for spheres of different diameters.

- (a) In one test, the spheres were dropped from the same height.

Determine the factor by which the kinetic energy of the sphere just before impact increases when the sphere diameter is increased from 2.0 cm to 4.0 cm.

(3)

$$M = \rho V$$

$$V_{\text{sphere}} = \frac{4}{3} \pi r^3$$

Mass increased by 8x

$$2^3 = 8$$

$$\frac{1}{2} m v^2 = KE$$

$\therefore KE$ increased by 3x

Factor = 3



The lack of a joined up approach to the solution makes it difficult to know what the candidate is thinking with this response. However, it is stated that the mass increases by a factor of 3, and then the equation for kinetic energy is quoted together with a statement that the kinetic energy increases by a factor of 3. From this we can infer that the speed of impact is the same for both spheres, and so there is a weak statement for mark point 1 in this response.



When writing your solution to a problem, be sure to include all the detail necessary to communicate your reasoning.

Question 12 (b)

This question required candidates to construct a coherent and logically structured answer with linkages between the physics points relevant to the situation. Most candidates could see that the first conclusion about the height was correct and many were able to confirm the simple, but correct, explanation in the question. Many candidates ignored the second conclusion in the last sentence, but those who did discuss it were able to say it was incorrect, and to give a reason for it. A large number of candidates did not notice the inconsistency in the pattern of data for sphere diameter, and so not many made the obvious point that more data was needed for a firm conclusion.

The student wrote the following conclusion:

"The greater the drop height, the greater the diameter of the crater formed when a sphere hits the sand. This is because the impact velocity increases as the drop height is increased. As the speed of the sphere increases the diameter of the crater formed also increases. Also, the bigger the sphere the bigger the crater."

Assess the validity of the student's conclusion.

The student's ⁽⁶⁾ first point about increasing the drop height of the sphere increases the diameter of the sphere is supported by his results as for each diameter of sphere, increasing drop height increases crater diameter. This is due to the spheres being accelerated under gravity for longer so ~~the~~ going deeper into the sand, due to an increased impact velocity, ~~and~~ therefore displacing more sand. However, the point about "the bigger the sphere the bigger the crater" is not backed up by their results as the largest sphere does not make the largest crater for the first two drop heights, so further testing may be required to back up that statement.



This response is succinct and hits all the indicative content points in the mark scheme. There is good linkage which produces a coherent argument and so the response gains 4 marks for content and 2 marks for linkage, giving a total of 6 marks.



When assessing the validity of a conclusion be sure to consider all the points made in the conclusion, and identify where evidence backs up the points being made.

The student wrote the following conclusion:

"The greater the drop height, the greater the diameter of the crater formed when a sphere hits the sand. This is because the impact velocity increases as the drop height is increased. As the speed of the sphere increases the diameter of the crater formed also increases. Also, the bigger the sphere the bigger the crater."

Assess the validity of the student's conclusion.

(6)

As the drop height increased (from 0.3m to 0.9m) for the same diameter sphere (e.g. 2cm), the crater diameter increased (3.6cm to 5.6cm). This supports the student's claim. Because gravitational potential energy at the height is equal to the kinetic energy before impact (assuming negligible air resistance), $mgh = \frac{1}{2}mv^2$ so height (h) is proportional to velocity (v) squared. ~~As~~ so the diameter increased as the velocity increased. ~~For~~ $F\Delta t = \Delta mv$ so at a greater velocity, a greater force is applied to the sand as the change of momentum over time increases. so more sand would move to form the crater at a larger velocity. For the same drop height, the crater diameter increases with sphere diameter, ^{for only 0.9m height} this is not supported by one result where ~~at~~ at 0.6m height, 4cm sphere creates 7.5cm diameter and 6.0 cm sphere creates 7.3cm, nor at 0.30 m for the same two spheres. As this occurred twice, this is unlikely to be an anomaly so the data doesn't support the conclusion of sphere size relating to crater size. However, more aren't enough results for each height and each type of sphere for this to be very reliable data.

(Total for Question 12 = 9 marks)



This response takes a more mathematical approach in its consideration of the student's conclusion. Again, the indicative content identified in the mark scheme is stated giving 4 marks for content. Linkage is good so gains 2 marks, giving a total of 6 marks for the response.



When making a point in the conclusion always refer to the evidence, and back your statement up with relevant theory.

Paper Summary

Based on their performance on this paper, candidates are offered the following advice:

- Ensure you have a thorough knowledge of the physics content of the whole specification.
- Be ready to apply your knowledge of core practicals and general techniques to questions testing your indirect practical skills.
- Read each question carefully, and answer what is asked.
- Show all workings in calculations.

For extended writing questions:

- Make a note of the marks available and include that number of different physics points in your response.
- Try to base the answer around a specific equation or principle.
- Formulate a response that is consistent with the command word used in the question.

Grade Boundaries

Grade boundaries for this, and all other papers, can be found on the website on this link:

<http://www.edexcel.com/iwantto/Pages/grade-boundaries.aspx>

