

Examiners' Report  
June 2018

GCE Physics 8PH0 01

## Edexcel and BTEC Qualifications

Edexcel and BTEC qualifications come from Pearson, the UK's largest awarding body. We provide a wide range of qualifications including academic, vocational, occupational and specific programmes for employers. For further information visit our qualifications websites at [www.edexcel.com](http://www.edexcel.com) or [www.btec.co.uk](http://www.btec.co.uk).

Alternatively, you can get in touch with us using the details on our contact us page at [www.edexcel.com/contactus](http://www.edexcel.com/contactus).



### Giving you insight to inform next steps

ResultsPlus is Pearson's free online service giving instant and detailed analysis of your students' exam results.

- See students' scores for every exam question.
- Understand how your students' performance compares with class and national averages.
- Identify potential topics, skills and types of question where students may need to develop their learning further.

For more information on ResultsPlus, or to log in, visit [www.edexcel.com/resultsplus](http://www.edexcel.com/resultsplus). Your exams officer will be able to set up your ResultsPlus account in minutes via Edexcel Online.

### Pearson: helping people progress, everywhere

Pearson aspires to be the world's leading learning company. Our aim is to help everyone progress in their lives through education. We believe in every kind of learning, for all kinds of people, wherever they are in the world. We've been involved in education for over 150 years, and by working across 70 countries, in 100 languages, we have built an international reputation for our commitment to high standards and raising achievement through innovation in education. Find out more about how we can help you and your students at: [www.pearson.com/uk](http://www.pearson.com/uk).

June 2018

Publications Code 8PH0\_01\_1806\_ER

All the material in this publication is copyright  
© Pearson Education Ltd 2018

## Introduction

This is the third time that the Pearson Edexcel AS paper 8PH0-01, Core Physics I, has been sat by students. Section A of the paper is worth 60 marks and consists of 8 multiple choice questions followed by 6 questions of increasing length comprising of short open, open-response, calculation and extended writing style questions. Section A examines material from the topics Working as a Physicist, Mechanics and Electric Circuits. Section B is worth 24 marks on this paper and examines material from the whole AS specification. It contains two questions worth 10 and 13 marks including a data analysis question based on an experiment to measure the speed of sound in air. Although this is not a core practical, it is similar to core practical 6 so it should be a context familiar to students from both their GCSE and their AS courses. The second question in section B was a synoptic question based on a liquid-crystal display.

This paper enabled students of all abilities to apply their knowledge to a variety of styles of examination questions. Many students showed a good progression from GCSE to AS level, with prior knowledge extended and new concepts taught and understood well. With the exception of question 9(b), most students answered the questions involving calculations ranging from 2 to 4 marks very well. Question 9(b) was only answered correctly by the most able learners, as many did not grasp the concept that the resistance of the voltmeter would decrease the resistance of the parallel branch of the circuit. Some questions were not answered as well as would have been expected by many learners; this was particularly evident in the open response and the extended writing questions. Learners that had a sound understanding of the physics involved did not always demonstrate this in their responses due to a lack of precision when applying their knowledge to the context, poor use of subject specific language and missing the point of the question due to being unfamiliar with the command terms. However, learners from across all ability ranges always managed to score some marks within these questions.

Timing was an issue for a small number of learners, usually due to spending a disproportionate amount of time answering the multiple choice items. 16(c) was mostly affected by this issue with many learners not spending sufficient time reading the stem and thinking about their response.

## Section A - Multiple choice questions 1-8

Only the top end learners were able to score at least 7 on the multiple-choice items. Whilst E grade learners scored, on average, 4 marks for these items. For middle ability learners and below, the performance with these items was not indicative of their overall performance in the exam. This is usually due to a disproportionate amount of time spend on the multiple choice items, particularly for less able learners, taking time away from the higher scoring questions later in the paper.

Question	Subject	Percentage of learners who answered correctly	Most common incorrect response
1	SI base units	45	B
2	Trajectory of a projectile	77	C
3	Resistance and temperature in a metallic conductor	81	C/D
4	Current-potential difference graphs for known components	56	A
5	Percentage uncertainty	48	A/B
6	Kinetic energy and work done	58	B
7	Core practical to determine the e.m.f. of a cell	28	B
8	Calculation to determine displacement	46	A

### Question 1

As is common with multiple choice items at the beginning of the paper, some learners do not answer as expected due to rushing though this first item on the paper. Surprisingly some very able learners dropped a mark as well and all would be advised to always re-visit this question if time is available. Some missed the instruction for SI base units and selected A or C, both giving correct SI units but not SI base units. The most common error was to miss the power of  $^{-1}$  and selected response B,  $A s^{-1}$  i.e. assuming it was giving  $A s$ , which is charge correctly quoted in SI base units.

### Question 2

The range cannot increase for a projectile launched at the same speed at a greater angle, if the original angle is greater than  $45^\circ$ . Distractors A and C are for projectiles launched at a greater angle, at greater speed. For the same launch speed, a greater angle can only reduce the range.

### Question 3

This multiple-choice question was answered more successfully than most of the other multiple-choice questions and only a small proportion failed to appreciate that, due to the increased number of collisions between charge carriers and lattice ions, the average distance between collisions will decrease and therefore the drift velocity will also decrease and not increase. A small number of learners confused this model with that of a thermistor, selecting response D, an increased number of conduction electrons per unit volume.

### Question 4

The graph given was perhaps presented in a less familiar way to learners in that it was of potential difference against current rather than the other way around. Hence many thought it to be the graph for a diode due to the sudden increase in the gradient, selecting distractor A, diode.

### Question 5

The uncertainty for each measurement using the metre rule is 1 mm so with a measurement of 93 cm the percentage uncertainty will be  $(0.1/93) \times 100 = 0.1\%$ . The majority of errors were due to not multiplying by 100 or confusion with unit conversions.

### Question 6

Another multiple response answered well, the majority of errors occurred when learners saw the term 'work done' and assumed that they have been given the force and the distance over which the force was applied and just multiplied together the two quantities given. This was a very straightforward question, only requiring use of the formula for kinetic energy and would have only been answered incorrectly due to the speed at which the learner read through the question.

### Question 7

Question 7 was based on core practical 3 to measure the internal resistance of a cell. The vast majority of learners realised that the parallel circuits given in distractors C and D were incorrect, but many were confused about the addition of a second resistor in the circuit and where to subsequently place the voltmeter. The remaining learners did not remember that the potential difference being measured must represent the output voltage of the cell and therefore the voltmeter must be connected across any components within the circuit and not just one.

### Question 8

This question was intended to test the learners' understanding of displacement. The most common incorrect response was A, the distance travelled around  $\frac{3}{4}$  of the internal circumference of the track. The displacement of the athlete is the shortest distance from the start position to the end position which could be calculated using Pythagoras ( $\sqrt{30^2 + 30^2} = 42$  m).

## Question 9 (a)

Specification point 36 requires learners to be able to derive the equations for combining resistances in both series and parallel. While it was very clear that many centres had covered this in detail, some learners still omitted steps or tried to work backwards with most recalling the end point of this derivation, the equation for the total resistance. The start point for all should have been the conservation of energy and a statement that the EMF of the cell was equal to the sum of all the individual potential differences in the circuit. Applying Ohm's law for each term should have led to a cancellation of the currents and a final expression for the total resistance in the circuit.

The question stated that the internal resistance of the cell is negligible, but some learners chose to start their derivation using  $V = E - Ir$ , which did not lead anywhere so many accompanied their response with a statement of the total resistance, as the end point was clearly known.

This response scored just 1 mark.

- 9 (a) Three resistors, of resistance  $R_1$ ,  $R_2$  and  $R_3$ , are connected in series across a cell. The cell has electromotive force (e.m.f.)  $\mathcal{E}$  with negligible internal resistance. The current through the cell is  $I$ .

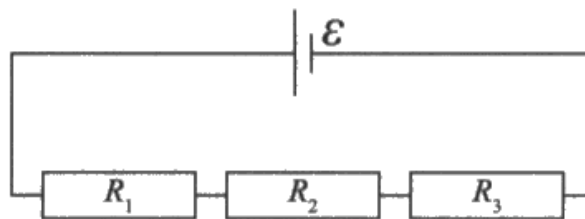

Derive the formula for the total resistance  $R_T$  of the circuit in terms of  $R_1$ ,  $R_2$  and  $R_3$ .

(3)

$$R = \frac{V}{I}, \quad R_T = R_1 + R_2 + R_3$$

$$\mathcal{E} = IR + Ir$$

$$\mathcal{E} = I(R+r)$$

$$\frac{\mathcal{E}}{I} = R \quad (r \text{ is negligible})$$

$$R_T = R_1 + R_2 + R_3$$



The learner clearly knew the equation for the total resistance for resistors in series but did not know where to start the derivation for this equation as no attempt was made to derive it.



To derive the total resistance for resistors in series, you need to start with a statement using the conservation of energy  $V_{\text{total}} = V_1 + V_2 + V_3$  and then use Ohm's law for each term.

To derive the total resistance of resistors in parallel, you need to start with a statement using the conservation of charge,  $I_{\text{total}} = I_1 + I_2 + I_3$  and then use Ohm's law for each term.

This response scored 2 marks, MP1 and MP3.

- 9 (a) Three resistors, of resistance  $R_1$ ,  $R_2$  and  $R_3$ , are connected in series across a cell. The cell has electromotive force (e.m.f.)  $\mathcal{E}$  with negligible internal resistance. The current through the cell is  $I$ .

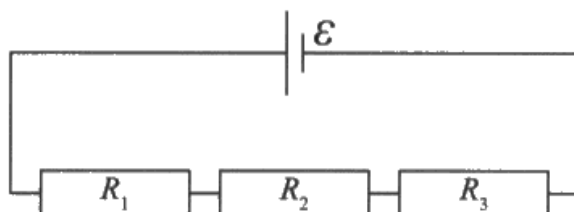

Derive the formula for the total resistance  $R_T$  of the circuit in terms of  $R_1$ ,  $R_2$  and  $R_3$ .

(3)

$$V_T = V_1 + V_2 + V_3$$

$$\mathcal{E} = V_1 + V_2 + V_3 \quad R = \frac{V}{I}$$

$$I_T = I_1 = I_2 = I_3$$

$$R_T = \frac{V_1}{I_1} + \frac{V_2}{I_2} + \frac{V_3}{I_3} = R_1 + R_2 + R_3$$



The learner started off correctly, using the conservation of energy to obtain a statement of the total potential difference across the components is equal to the EMF of the cell. They then divided the individual voltages by the currents rather than replace each potential difference using Ohm's law, therefore this method did not lead them to the correct statement.

The learner, did however state the correct equation at the end which allowed MP3 to be awarded. There was no justification for this but the marking points were independent.



### Question 9 (b)

Very few learners managed to answer this question successfully. Those who correctly calculated a resistance of 240 Ω usually used the potential divider formula to obtain the total resistance of the parallel branch. They then successfully used the formula for the total resistance in a parallel circuit to obtain the resistance of the voltmeter.

Some learners did manage to score 1 mark for using Ohm's law with the p.d. across the voltmeter and what they thought to be the current in the voltmeter. Less able learners ignored the 1.85 V and assumed that the voltage was split 2V and 4V across the resistors, ignoring any reduction in the resistance due to the resistance in parallel of the voltmeter. Many could not correctly determine the current through the voltmeter, assuming that the current through the 40 Ω resistor was 0.05 A (6/120).

This response scored all 3 marks.

- (b) The circuit diagram shows two resistors in series across a battery of e.m.f. 6.0 V and negligible internal resistance. A voltmeter with low resistance is connected across the 40 Ω resistor.

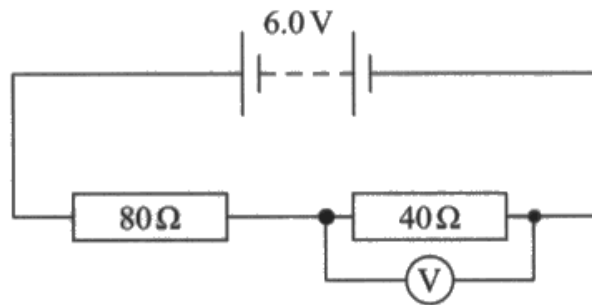

The reading on the voltmeter is 1.8 V.

Calculate the resistance of the voltmeter.

$$\frac{1.8}{6} = 0.36 \times \frac{R_v}{80 + R_v} = 1.8 \quad (3)$$

$$6R_v = 144 + 1.8R_v$$

$$4.2R_v = 144$$

$$\frac{1}{240} = \frac{1}{40} + \frac{1}{R_v} \quad R = \frac{240}{7} \quad (\text{where } R \text{ is total for resistor and voltmeter})$$

$$\frac{1}{R_v} = \frac{1}{240}$$

$$R_v = 240 \Omega$$

Resistance of voltmeter = 240 Ω

(Total for Question 9 = 6 marks)



The learner used a ratio of the resistance  $R$  across the parallel section compared to the total resistance,  $80 + R$ , with the p.d. across the parallel section compared to the total p.d. (i.e. the potential divider equation) to determine the total resistance of the parallel circuit, leaving their answer as a fraction. This is fine for interim calculations but not for the final answer.

They then used the equation for the total resistance of resistors in parallel to determine the resistance of the voltmeter.

This was a more typical response scoring just 1 mark for MP2, using the alternative marking route (the 'Or') on the mark scheme.

- (b) The circuit diagram shows two resistors in series across a battery of e.m.f. 6.0 V and negligible internal resistance. A voltmeter with low resistance is connected across the 40 Ω resistor.

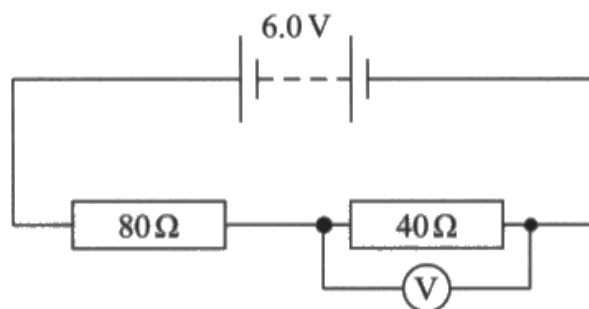

The reading on the voltmeter is 1.8 V.

Calculate the resistance of the voltmeter.

(3)

$$\frac{40}{120} = \frac{1}{3}$$

$$\frac{6}{120} = I = 0.05A$$

$$\frac{1.8}{0.05} = R = 36\Omega$$

Resistance of voltmeter = 36 Ω



The learner has assumed that the total resistance of the parallel section of the circuit is 80 Ω and has ignored the fact that the voltmeter has its own resistance. They then used Ohm's law to calculate an incorrect value for the current in the circuit. They then assumed that this is also the current in the voltmeter and used Ohm's law again, this time with the correct p.d. across the voltmeter to determine what they think is the resistance of the voltmeter.

## Question 10 (a)

This short open response gave the learners no direction as how they should approach their explanation. Only learners that took a mathematical approach, identifying the angle to refer to and forming an equation in terms of the tension and the weight of the picture were successful. Some learners did try to answer in terms of stress and extension in the wire and were rarely successful in picking up any marks. Only the most able learners managed to resolve the vertical forces and state  $mg = T \cos \theta$  as they took into account the factor of two for the tension in each half of the wire and gave the correct equation  $mg = 2T \cos \theta$ . More learners answered in terms of sine, using the angle to the horizontal, while a small number did not define  $\theta$  by drawing this onto the diagram or describing it within their answer. Some good responses used sensible values substituted into the equation to demonstrate that the first arrangement produced a lower tension.

This response did not score any marks.

- 10** A thin wire of negligible mass is used to hang a picture on a wall. The wire is hung over a nail and can be attached to the picture using arrangement 1 or arrangement 2, as shown.

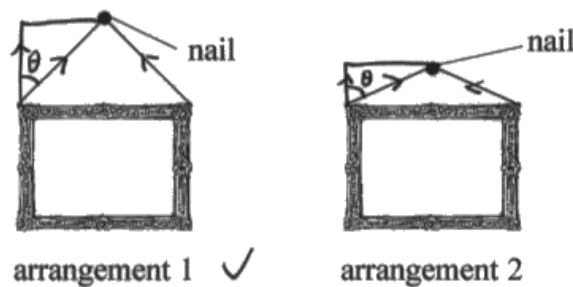

- (a) Deduce which wire arrangement should be used to keep the tension in the wire as small as possible.

vertical.

(4)

$$T \cos \theta \text{ (Tension in } \uparrow \text{ direction)} = T \cos \theta$$

For arrangement 1, the tension in  $\uparrow$  direction is a relatively bigger portion of the tension, so the tension can be relatively smaller to produce the same amount of force in  $\uparrow$  direction.

Therefore in comparison, arrangement 2 has a smaller portion of vertical tension, tension would have to be bigger to produce the same amount of vertical tension.

Arrangement 1 should be used.



Although the learner has resolved correctly for the tension, the vertical component of tension has not been equated to the weight, or more correctly, to half of the weight. Therefore they had no basis for their subsequent discussion and no marks could be scored.



You need to consider all of the forces acting on a system before any conclusion can be made about the size of an individual force.

This response scored all 4 marks.

- 10 A thin wire of negligible mass is used to hang a picture on a wall. The wire is hung over a nail and can be attached to the picture using arrangement 1 or arrangement 2, as shown.

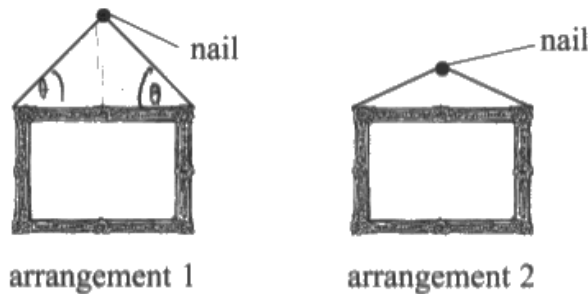

- (a) Deduce which wire arrangement should be used to keep the tension in the wire as small as possible.

$$\text{Tension} = \frac{\text{Weight}/2}{\sin \theta} \quad \text{where } \theta = \text{angle to the horizontal} \quad (4)$$

as  $\theta$  increases so does  $\sin \theta$   
 $\therefore$  as the weight is the same in both arrangements but  $\theta$  is greater in arrangement 1, arrangement 1 could have a lower tension in the wire. So arrangement 1 should be used.



Starting with a correct equation for the resultant force, tension = (weight/2)/sin $\theta$ , enabled the learner to correctly describe the effect of increasing the angle  $\theta$  i.e. make a comparison between arrangement 1 and arrangement 2. Leading to the correct conclusion that arrangement 1 is more suitable as it produces a lower tension.

This response scored 2 marks.

- 10 A thin wire of negligible mass is used to hang a picture on a wall. The wire is hung over a nail and can be attached to the picture using arrangement 1 or arrangement 2, as shown.

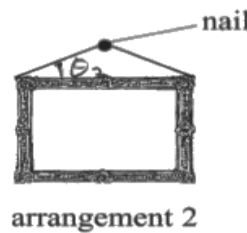
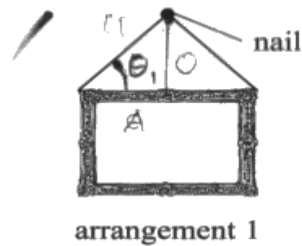

$$\sin \theta = \frac{O}{H}$$
$$H = \frac{O}{\sin \theta}$$

- (a) Deduce which wire arrangement should be used to keep the tension in the wire as small as possible.

(4)

$T = \frac{mg}{2 \sin \theta}$  The tension in the wire can be found by ~~dividing~~ dividing half the weight of the picture by  $\sin \theta$ ,  $\theta$  being the angle to the horizontal.  $\therefore$  if the weight is constant:

$$T = \frac{mg}{2 \sin \theta}$$

then

$$T \propto \frac{1}{\theta}$$

$\theta_1 > \theta_2 \therefore$  The larger angle will result in the lowest tension. i.e. arrangement 1



Unfortunately this learner forgot that there are effectively two tensions that should be equal to the weight and the factor of 2 was not included in the equation for the resultant force and MP2 could not be awarded. The learner did go on to make a sensible statement about a greater angle resulting in a lower tension and arrangement 1 being more suitable. There was no justification as to why a smaller angle would result in a lower tension i.e. greater  $\theta$  so  $\sin \theta$  is greater, so no MP3 here.

## Question 10 (b)

Learners were required to use the idea of moments to explain why the system was not in equilibrium in arrangement 1 and why the system settled in the position in arrangement 2. Many responses only defined a system in equilibrium with balanced moments without applying any of their response to the two arrangements and a smaller number assumed that arrangement 2 was not in equilibrium, and effectively gave a description for the two arrangements the wrong way round.

Learners that attempted to explain the perpendicular distance between the line of action of the weight and the pivot mostly forgot to refer to a force and just referred to there being a perpendicular distance without adding further explanation. Marking points 1 and 3 were the most generously worded and therefore the most frequently awarded and, although MP2 was not seen as often, the physics involved was clearly known by most learners. A lack of detail therefore prevented many from scoring MP2 in that they referred to a moment but did not state which force was causing the moment or refer to both the clockwise and anti-clockwise moments.

This response scored no marks.

- (b) It was observed that if the wire was not hung with its midpoint over the nail, as in Diagram 1, the picture moved and then remained in the position shown in Diagram 2.

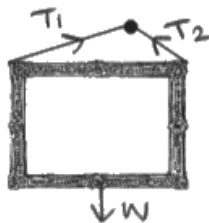

Diagram 1

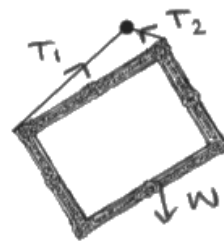

Diagram 2

Use the idea of moments to explain why.

(3)

The principle of conservation of moments states that clockwise moments = anticlockwise moments if the system is in equilibrium. In diagram ~~1~~<sup>2</sup>, taking the nail as the pivot, the moment of tension on the left of the pivot will be larger as the <sup>perpendicular</sup> distance from the pivot to the force will be larger. Therefore, the clockwise moment will be larger so the system will no longer be in equilibrium. (Total for Question 10 = 7 marks)





Stating the principle of moments was not applying any physics to the context and did not help the learner answer the question.

Unfortunately this learner assumed, as did many, that arrangement 2 was the image not in equilibrium. Therefore no credit could be given. Had the points made been describing MP1 then MP1 and MP2 could have been awarded.



Read the question, these are unfamiliar contexts, however simple they seem, so that a key piece of information is not missed. Every piece of information, particularly in the case of 1Q0(b), is given for a reason so you should take note of all of the information given.

A good response scoring all 3 marks.

- (b) It was observed that if the wire was not hung with its midpoint over the nail, as in Diagram 1, the picture moved and then remained in the position shown in Diagram 2.

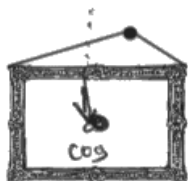

Diagram 1



Diagram 2

Use the idea of moments to explain why.

(3)

~~In diagram 1, the tension on the wire upwards force on the weight is much less because the tension is lower even though the distance from the pivot is the same. The weight of the object is now at a distance perpendicular from the pivot, where as if the center of gravity is directly under the nail then the perpendicular distance from the line of action of the force to the pivot is 0. There fore there is no moment.~~

The weight of the object is now at a distance perpendicular from the pivot, where as if the center of gravity is directly under the nail then the perpendicular distance from the line of action of the force to the pivot is 0. There fore there is no moment.

(Total for Question 10 = 7 marks)

When the picture is moved so the center of gravity is not below the nail, the distance from the line of action of the force to the pivot is  $> 0$  so there is a moment. After it has tilted, the center of gravity is back under the pivot (nail) so there is no ~~moment~~ moment so the picture remains still.



MP1 was scored for lines 1-2 for indicating that the weight now has a perpendicular distance from the pivot.

MP2 was awarded for the idea that the weight now has a moment in line 8.

MP3 was awarded for a description of the picture in equilibrium in line 9.

## Question 11 (a)

Learners in the majority of cases answered this very well with the majority scoring all four marks. Learners only got into difficulty, often without realising, if they tried to determine the initial direction based on the horizontal and vertical distances travelled during the first half of the motion of the ball, which also produced an initial direction of  $21^\circ$ .

MP1 was the most commonly awarded for seeing the initial horizontal velocity of  $25 \text{ m s}^{-1}$ , while some less able learners then went along the distance route from here, sometimes mixing a velocity and a distance in their final calculation with  $\tan$  to obtain a direction.

This response scored all 4 marks.

11 A fairground game requires the player to catapult a ball towards a target to score points.

The ball is required to reach a target a horizontal distance of 50m away, at the same vertical height, as shown.

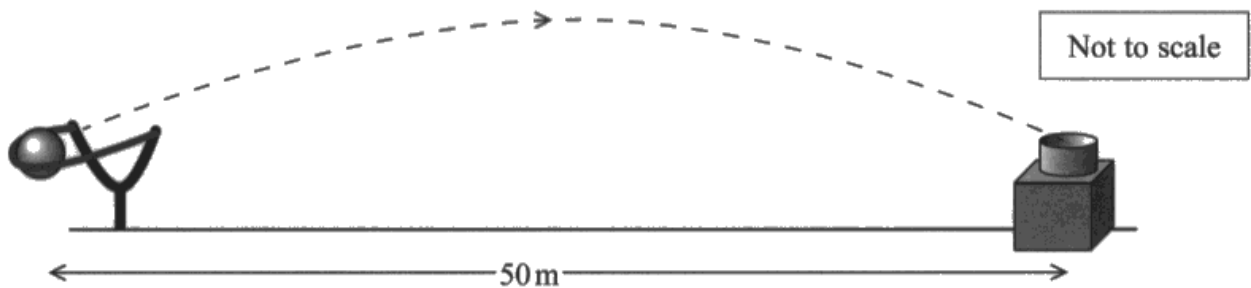

(a) The time taken for the ball to reach the target is 2.0 s.

Calculate the angle to the horizontal at which the ball is launched.

(4)

$$s = 50$$

$$u = ?$$

$$v = x$$

$$a = -9.81$$

$$t = 2$$

$$s_h = u_h t$$

$$50 = u_h \cdot 2 \quad \therefore u_h = 25 \text{ m s}^{-1}$$

$$s_v = u_v t + \frac{1}{2} a t^2$$

$$0 = u_v(2) + \frac{1}{2}(-9.81)(2)^2$$

$$19.62 = u_v \cdot 2$$

$$\therefore u_v = 9.81 \text{ m s}^{-1}$$

$$\tan^{-1}\left(\frac{9.81}{25}\right) = \theta_h \quad \therefore \theta_h = 21.4^\circ$$

$$\text{Angle to the horizontal} = 21.4^\circ$$

The initial horizontal velocity of  $25 \text{ m s}^{-1}$  has been calculated. The initial vertical velocity was then determined using  $s = ut + \frac{1}{2}at^2$  giving the correct value of  $9.81 \text{ m s}^{-2}$ . Finally the learner used  $\tan(\text{launch angle}) = 9.81/25$  giving a launch angle of  $21^\circ$ .

This response scored 2 marks.

**11** A fairground game requires the player to catapult a ball towards a target to score points.

The ball is required to reach a target a horizontal distance of 50 m away, at the same vertical height, as shown.

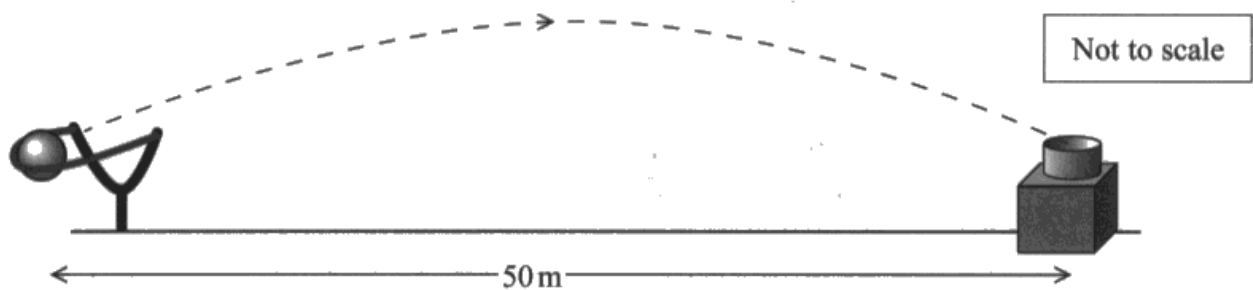

(a) The time taken for the ball to reach the target is 2.0 s.

Calculate the angle to the horizontal at which the ball is launched.

(4)

$s = ut$  horizontally:

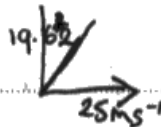

$50 = 2u$

$u = 25 \text{ m s}^{-1}$

~~Apply  $s = ut + \frac{1}{2}at^2$  vertically~~

Apply  $v = u + at$  vertically

~~$25 = \frac{1}{2}(9.81)(2)$~~

$0 = u - (9.81)(2)$

$u = 19.62 \text{ m s}^{-1}$

$\tan(\theta) = \frac{19.62}{25}$

$\therefore \theta = \tan^{-1}\left(\frac{19.62}{25}\right)$

$\theta = 38.12^\circ$

Angle to the horizontal =  $38.12^\circ$



The learner calculated correctly the initial horizontal velocity of  $25 \text{ m s}^{-1}$  and then used  $v = u + at$  to determine the initial vertical velocity. Using a final velocity of 0 meant that they were only considering the motion up to the maximum height. The time taken to reach this height is 1 second and not 2 seconds as the student has used here. Therefore the initial vertical velocity was incorrect and MP2 could not be awarded.

The learner did go on to use these two velocities correctly to determine the launch angle. MP3 could be awarded but not MP4 as the final answer was incorrect.



This question requires use of  $s, u, v, a, t$  equations.

Always list any values you have for any  $s, u, v, a, t$  quantities and make sure that they correspond and are for the same parts of the motion of the projectile e.g. entire motion or just motion to the maximum height.

## **Question 11 (b)**

This was another calculation question answered well by most learners. Some chose to ignore the instruction to draw a labelled vector diagram and used trigonometry, usually successfully, to determine the resultant force and direction. Such a method negated MP1 and MP2 as although the correct answers were obtained, part of this question was examining the students' ability to construct correct vector diagrams. The vast majority though did draw out a vector diagram, to scale, usually labelling the 2 N and 9 N forces as required by MP1. Many able learners however, could not score MP2 due to omitting directions that are a requirement of a vector diagram and this was most commonly for the resultant force. Just to note as well, a small number of learners produced an answer slightly out of range, even with a correctly scaled vector diagram because the initial angle between the 2 N and 9 N forces was not measured out accurately enough in the initial construction of the vector diagram.

2 marks awarded.

- (b) During another launch, the catapult exerts a force on the ball of 9.0 N at 40° to the horizontal at the time of release.

Draw a labelled vector diagram to determine the resultant force acting on the ball at the time of release.

(4)

weight of ball = 2.0 N

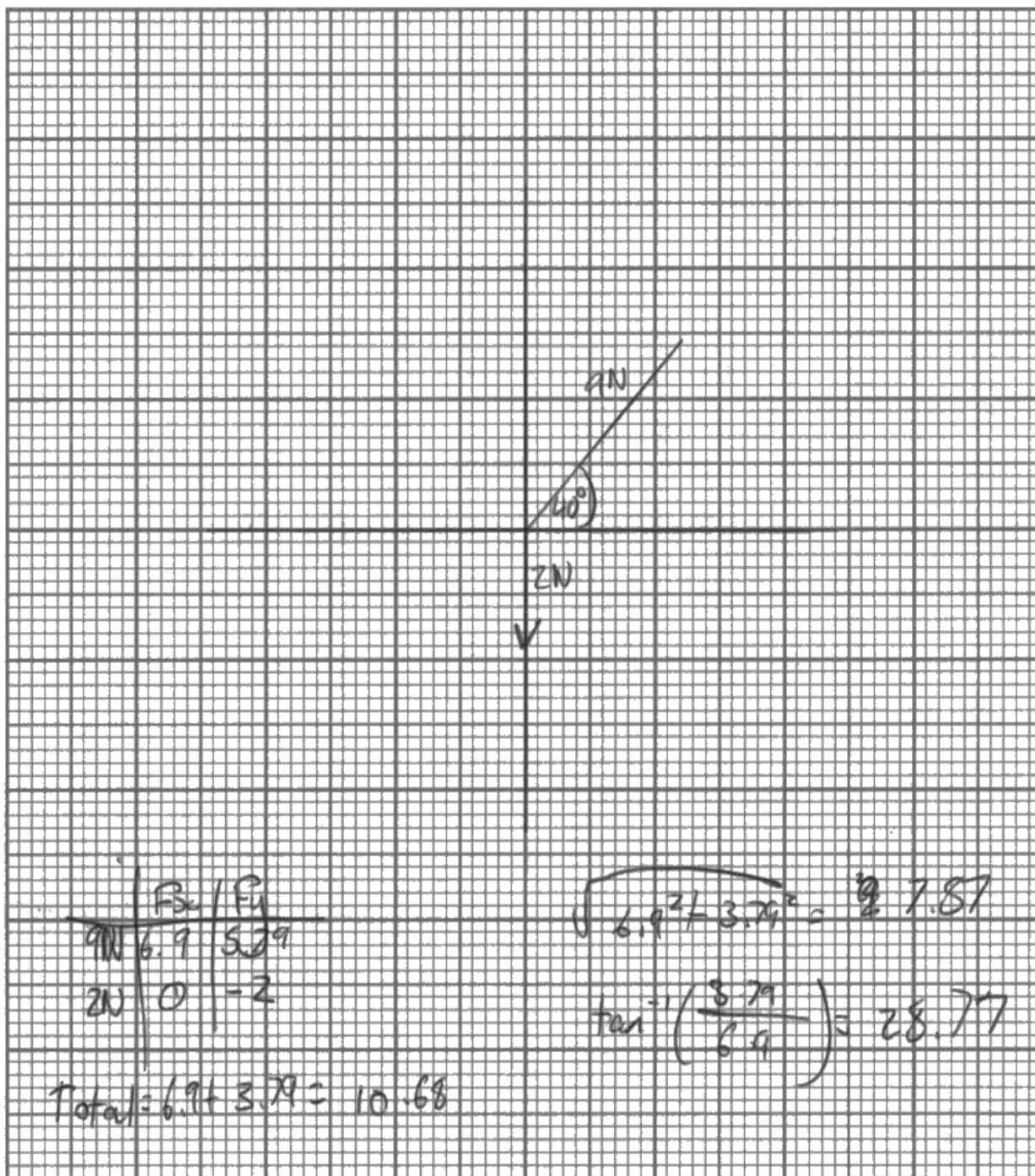

Magnitude of resultant force = 7.87 N

Angle of resultant force to the horizontal = 28.77°



No vector diagram has been constructed so no MP1 and MP2 awarded.

The learner resolved the 9 N force into x (horizontal) and y (vertical) components, subtracted the x components to give the resultant horizontal force and then used Pythagoras to determine the resultant force and trigonometry to determine the direction of the initial force.

MP3 and MP4 only awarded.



If a scaled vector diagram is requested, you must use this as your method to determine the quantity being asked for in the question. This is a separate skill and you are being examined on this as well as your ability to reach the final, correct answer.



3 marks awarded for this response.

- (b) During another launch, the catapult exerts a force on the ball of  $9.0\text{ N}$  at  $40^\circ$  to the horizontal at the time of release.

Draw a labelled vector diagram to determine the resultant force acting on the ball at the time of release.

(4)

weight of ball =  $2.0\text{ N}$

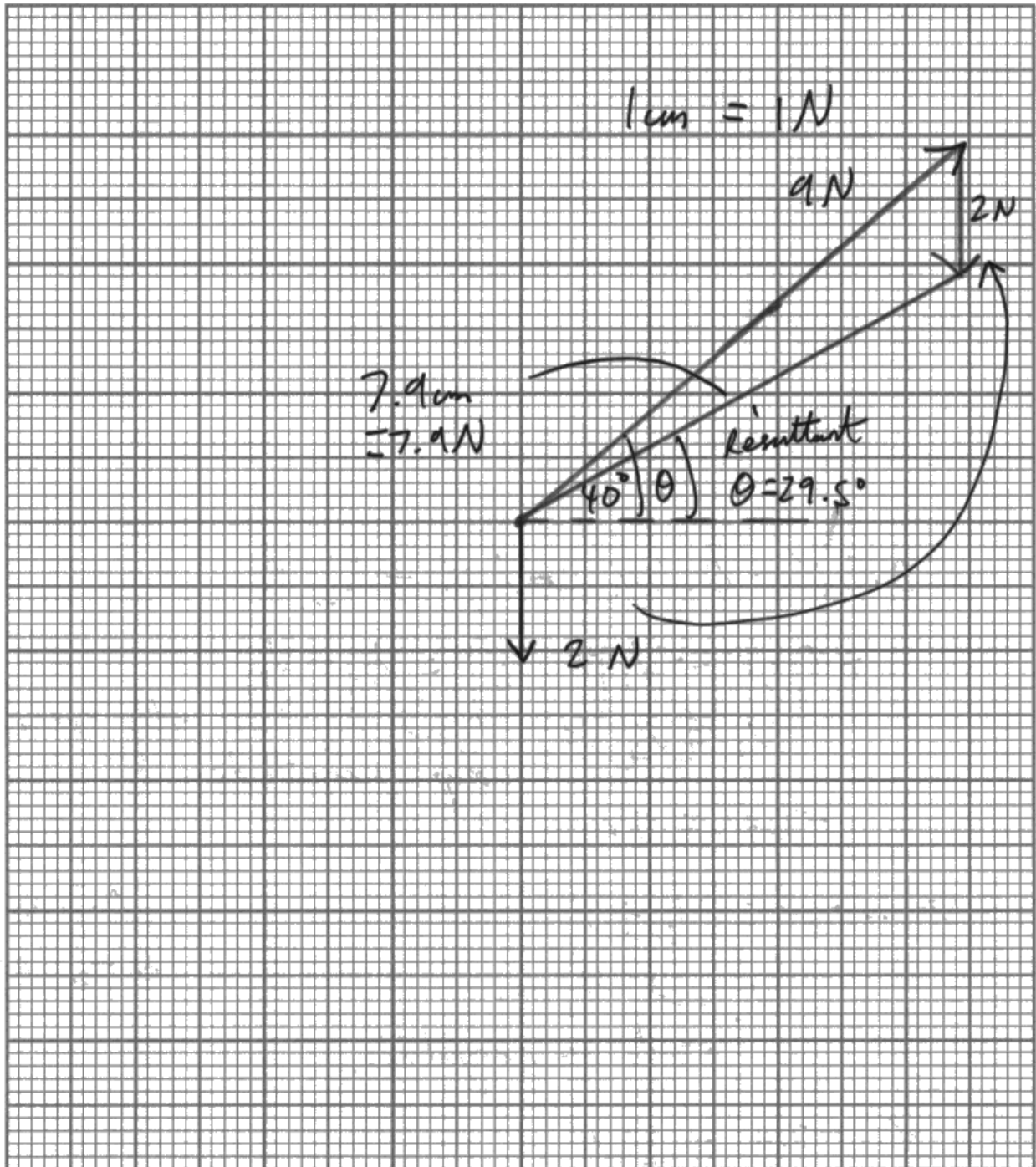

Magnitude of resultant force =  $7.9\text{ N}$

Angle of resultant force to the horizontal =  $29.5^\circ$



A vector diagram has been drawn to scale and the magnitude and direction have been measured accurately from the diagram giving answers in range.

MP2 was the only marking point that could not be awarded as the direction for the resultant force was not drawn onto the vector diagram.



Vector diagrams must be to scale and show the direction of every vector included, including the resultant.

This was a good response scoring all 4 marks.

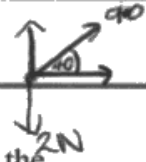

(b) During another launch, the catapult exerts a force on the ball of 9.0 N at  $40^\circ$  to the horizontal at the time of release.

Draw a labelled vector diagram to determine the resultant force acting on the ball at the time of release.

$$F = ma$$
$$= 2g$$
$$m = 0.2g$$

(4)

weight of ball = 2.0 N

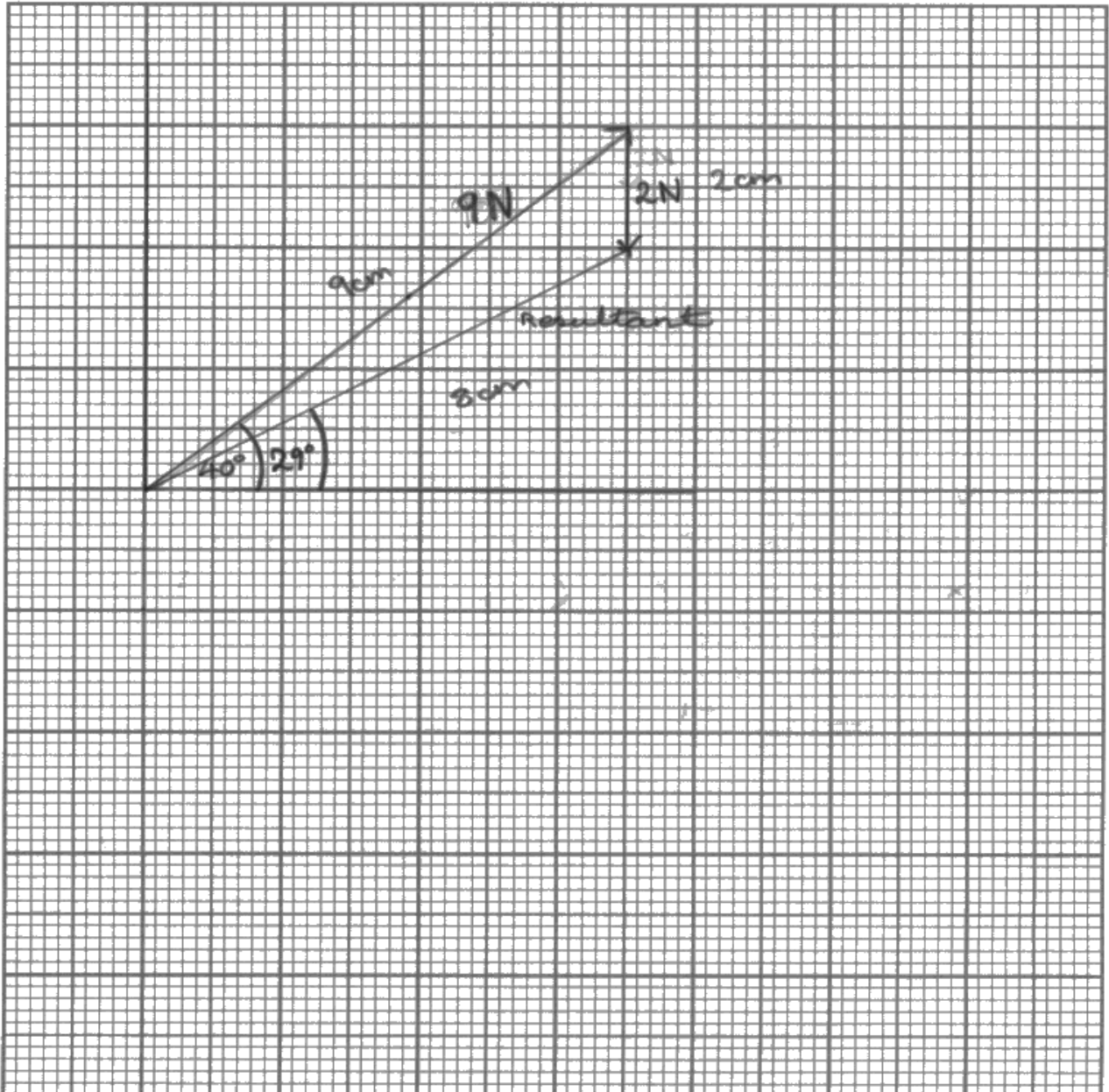

Magnitude of resultant force = 8 N

Angle of resultant force to the horizontal = 29°



A correct scaled vector diagram, including all directions, has been drawn. Measurements have been taken giving values for the magnitude and direction of the resultant force at launch in range.

## **Question 12 (a)**

Question 12(a) required learners to use the principle of conservation of momentum to determine the velocity of the gliders after the collision. The physics being examined is no more challenging than would be found on a GCSE level, however the omission of the mass confused many.

While a large proportion of responses included the momenta of the gliders before the collision, with  $0.7m$  and  $0.3m$  seen, these values were either added or learners did not know what to do with them and just left their answer as  $0.4 \text{ m s}^{-1}$ .

Only a small number of learners correctly identified the momentum after the collision as  $2mv$  and could successfully obtain a final velocity of  $0.2 \text{ m s}^{-1}$ . Some learners that only answered in terms of velocity i.e.  $0.3 - 0.7$ , omitting the mass and not progressing any further, were not able to score an interim working mark due to this incorrect method. The quoted direction of the gliders after the collisions was usually correct with learners appreciating the significance of the negative sign in their calculated velocity.

A good response scoring all 3 marks.

- 12 A teacher uses a linear air track to provide a frictionless surface for two gliders, each of mass  $m$ . She uses this, with a pair of light gates connected to a computer, to investigate a collision between the gliders.

The gliders are each given a small push and travel towards the centre of the track. The gliders collide and move off together.

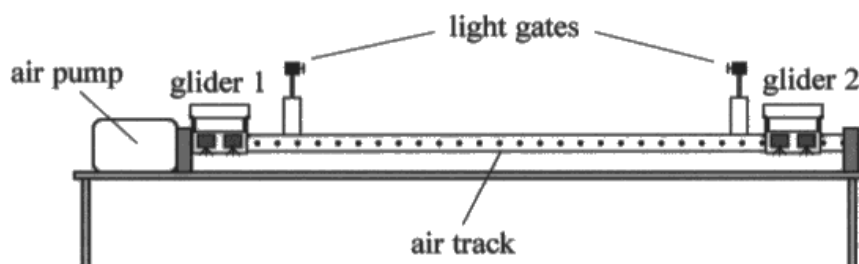

- (a) The computer displays the velocity of the gliders as they pass through the light gates.

Calculate the velocity of the gliders after the collision, using the principle of conservation of linear momentum.

(3)

initial velocity of glider 1 =  $0.30 \text{ m s}^{-1}$  to the right  
initial velocity of glider 2 =  $0.70 \text{ m s}^{-1}$  to the left

initial momentum:  $0.3m - 0.7m = -0.4m \text{ kgms}^{-1}$

final momentum:  $v(m+m) = 2mv$

initial momentum = final momentum

$\therefore -0.4m = 2mv \quad -0.4 = 2v$

$v = \frac{-0.4}{2} = -0.2 \text{ ms}^{-1}$

Magnitude of velocity =  $0.2 \text{ ms}^{-1}$

Direction of velocity = left



Right has been taken as the positive direction and the student has a correct expression for the total initial momentum of  $-0.4mv$ . This has been equated (due to the conservation of momentum) to the total final momentum of  $2mv$  leading to a velocity of  $0.2 \text{ m s}^{-1}$  i.e.  $2 \text{ m s}^{-1}$  to the left.

A more typical response, scoring 1 mark.

- 12 A teacher uses a linear air track to provide a frictionless surface for two gliders, each of mass  $m$ . She uses this, with a pair of light gates connected to a computer, to investigate a collision between the gliders.

The gliders are each given a small push and travel towards the centre of the track. The gliders collide and move off together.

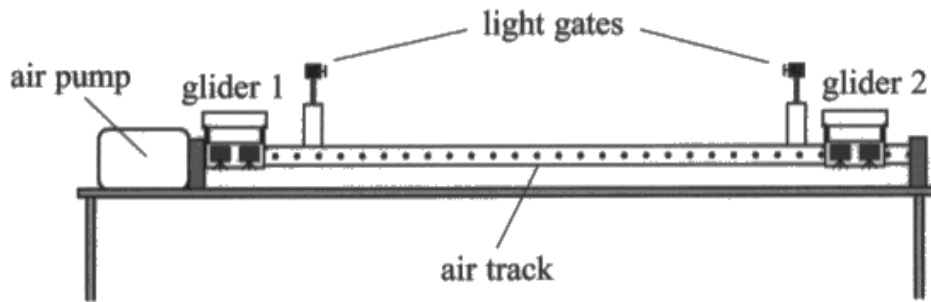

- (a) The computer displays the velocity of the gliders as they pass through the light gates.

Calculate the velocity of the gliders after the collision, using the principle of conservation of linear momentum.

(3)

initial velocity of glider 1 =  $0.30 \text{ m s}^{-1}$  to the right

initial velocity of glider 2 =  $0.70 \text{ m s}^{-1}$  to the left

$$p = mv \quad \begin{array}{l} \text{Before} \\ (+0.3)(m) + (0.7)(m) = 0.4m \\ (-0.3)(m) \end{array} \quad \begin{array}{l} \text{After} \\ 0.4m \end{array}$$

$$0.4 \text{ m s}^{-1} = \text{velocity after}$$

Magnitude of velocity =  $0.4 \text{ m s}^{-1}$

Direction of velocity = left



This time motion to the left has been taken as positive. The student has correctly stated that the final momentum is  $0.4m$  but has not equated this to the expression for the final momentum in terms of the final velocity i.e.  $0.4m = 2mv$ . The value quoted on the answer line is not the velocity, the mass being dropped from the expression for the final momentum.

Only MP1 for use of  $p = mv$  could be credited.



## Question 12 (b)

Question 12(b) asked learners to complete the incomplete explanation, justifying the change of velocity of glider 1 after the collision. Many answers included statements of Newton's 1<sup>st</sup> and 3<sup>rd</sup> law without applying them to the context of the gliders. Other responses were incomplete and described equal and opposite forces on glider 1 and glider 2, often identifying that this was an application of Newton's third law, but failing to identify the origin of the forces i.e. which object was applying these forces. At this point, a fair number of learners went on to discuss glider 2 and not glider 1, as the question had requested. Those that identified that there was now a resultant force on glider 2, often linked this to Newton's 2<sup>nd</sup> law and not the 1<sup>st</sup> law. Marks were therefore not scored as expected with many scoring just 1 mark and only the most able scoring 3 marks or more.

This response scored just 1 mark.

- (b) The teacher asked a student to justify the change in velocity of glider 1 using Newton's laws of motion.

The student began his explanation with the statement:

"During the collision there is a force on glider 2"

Complete the explanation to justify the change in velocity of glider 1, making reference to Newton's laws of motion where appropriate.

(4)

When glider 2 coalesces with glider 1 there is a resultant force on glider one. Newton's 2<sup>nd</sup> law states that  $F = ma$  meaning if there is acceleration there is an resultant force. Glider 1 is halted and accelerates to a constant speed in the other direction. Meaning there must be a resultant force acting on it.



MP3 was awarded for the idea that there is now a resultant force acting on glider 1. This is stated in line 2 and the last line.

The statement has not been completed and the student has only addressed the change in velocity of glider 1, as mentioned in the stem.



To get from a force on one object to a force on a second object during a collision Newton's 3<sup>rd</sup> law must be considered. Therefore, as a starting point a response should always be broken down into which object is applying the force and the object which the force is applied to.

This response scored 3 marks.

- (b) The teacher asked a student to justify the change in velocity of glider 1 using Newton's laws of motion.

The student began his explanation with the statement:

"During the collision there is a force on glider 2"

Complete the explanation to justify the change in velocity of glider 1, making reference to Newton's laws of motion where appropriate.

During the collision there is a force on glider 2 <sup>(4)</sup> from glider 1 and  
N3 states that glider 2 applies an equal and opposite  
force back on glider 1; <sup>which is opposite to its direction of motion</sup> This force causes a  
resultant force to act on glider 1 and <sup>N2</sup> Newtons  
states that  $F=ma$  where  $F$  is resultant force.  
Therefore, as a resultant force acts on glider  
1 it accelerates causing its velocity to change,  
and therefore changes its direction.



This learner has clearly completed the statement, describing each object applying a force and which object each forces is applied to, leading to a discussion of just glider 1 and its resulting motion.

MP4 was the only mark not awarded as the learner referred to Newton's 2<sup>nd</sup> law for the change in velocity (and hence direction) of glider 2 and not Newton's 1<sup>st</sup> law.



Newton's 3<sup>rd</sup> law is between **two** objects so both need to be mentioned.

Newton's 1<sup>st</sup> law is just looking at the resultant force acting on **one** object and the motion as a result of this resultant force.

## **Question 13 (a)**

This question required students to apply their knowledge and understanding of resistance and resistivity to resistivity surveying. Both questions 13(a) and 13(b) demonstrated a sound understanding of these concepts, with the majority of students scoring full marks over the question as a whole.

The vast majority of students linked an increase in length to an increase in resistance to gain MP2. A large number of students could then successfully link an increase in resistance to an increased p.d. and hence increased reading on the voltmeter. A small number of students attempted to gain MP2 through describing the system as a potential divider.

The most common error was due to an apparent misunderstanding between the p.d. that the voltmeter reads and the energy lost by electrons. These students generally recognised that there would be a larger voltage drop, however, stated that this would cause the voltmeter reading to drop too.

A good response scoring both marks.

13 Archaeologists use resistivity surveying of soil to search for the remains of buildings and settlements under the ground.

A basic arrangement that can be used to determine the resistivity of a region of soil is shown.

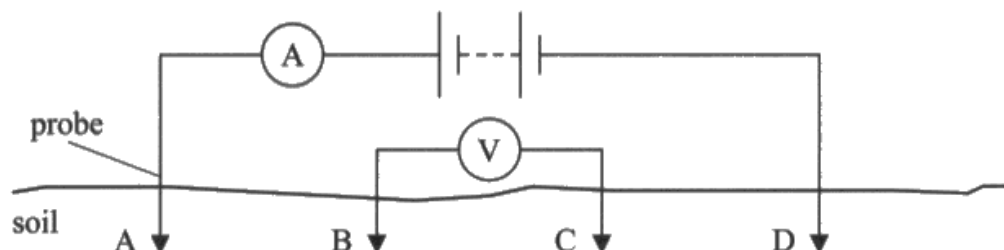

Probes are placed at positions A and D so that the length AD of soil forms part of the circuit. The ammeter measures the current through the soil.

A second pair of probes connected to a voltmeter is placed at positions B and C. This measures the potential difference between positions B and C in the soil.

(a) Explain how the reading on the voltmeter will change if the length BC increases.

Due to the equation  $R = \frac{\rho l}{A}$  ~~know~~ the length increasing causes an increase in resistance.  $R = \frac{V}{I}$  so when resistance increases and I is constant as it's the same soil then voltage will also increase. Resistance is directly proportional to voltage. (2)



A clear statement that the resistance is increasing so the voltage will also increase has been included.

One mark scored for a description, effectively three times, of MP1.

**13** Archaeologists use resistivity surveying of soil to search for the remains of buildings and settlements under the ground.

A basic arrangement that can be used to determine the resistivity of a region of soil is shown.

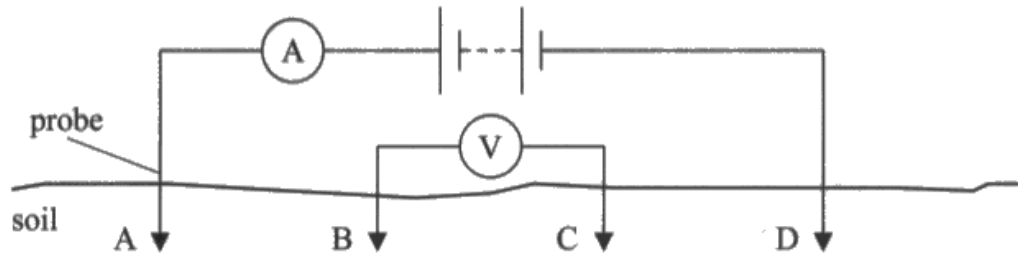

Probes are placed at positions A and D so that the length AD of soil forms part of the circuit. The ammeter measures the current through the soil.

A second pair of probes connected to a voltmeter is placed at positions B and C. This measures the potential difference between positions B and C in the soil.

(a) Explain how the reading on the voltmeter will change if the length BC increases.

(2)

The pd reading on the voltmeter should increase between the potential difference between both points will be bigger. The difference in voltage between both points will increase.



The student has not explained why the voltmeter reading would increase. Just stating that the p.d. has increased is not adding any more to the explanation as it does not justify the increase in p.d. across the length BC.

### Question 13 (b)

As was seen with question 11(a), students generally performed the calculations very well. The majority of students scored all 4 marks for calculating the resistance of the soil for each given p.d., determining the resistivity and selecting from the table a possible material in the soil sample. A small number did reverse working to show the given voltages linked in a range using the upper and lower limits for the resistivity of each material. This reverse method was also valid, however, some students did not use a range and picked a midpoint in the resistivity range or a max/min resistivity. Therefore, without a range of p.d.s to choose from, they could not state with absolute certainty which materials were used and only MP1 and MP2 for use of the two formulae could be credited.

A good response scoring all 4 marks.

(b) The table gives the resistivity of some different materials.

Material	Resistivity / $\Omega m$
Undisturbed clay	4–20
Compacted clay	100–200
Limestone	500–1000
Sandstone	1500–10 000

The probes connected to the voltmeter are kept at a constant separation of 0.75 m and are moved along the soil between positions A and D.

The current is constant at 9.5 mA. The voltmeter reading varies between 1.8 V and 8.0 V.

It can be assumed that the sample of soil under investigation has a cross-sectional area of 0.65 m<sup>2</sup>.

Deduce two possible materials that could be present in the soil between positions A and D.

(4)

$$V = IR$$

$$R = \frac{\rho l}{a}$$

$$\frac{V}{I} = R$$

$$\frac{1.8}{9.5 \times 10^{-3}} = 189.47 \Omega$$

Compacted clay

and limestone

could be present.

$$\frac{\rho \times 0.75}{0.65}$$

$$189.47 = \frac{\rho \times 0.75}{0.65}$$

$$\frac{189.47 \times 0.65}{0.75} = \rho = \underline{164.207 \Omega m} \rightarrow \underline{\text{Compacted clay}}$$

$$\frac{8}{9.5 \times 10^{-3}} = 842.1$$

$$\frac{\rho \times 0.75}{0.65}$$

$$842.1 = \frac{\rho \times 0.75}{0.65}$$

$$\rho = \underline{781.95 \Omega m} \rightarrow \underline{\text{Limestone}}$$





The student has used  $V = IR$  with the given current and voltmeter reading and  $R = \rho l/A$  with the calculated resistance to determine resistivities of  $164.207 \Omega \text{ m}$  and  $731.95 \Omega \text{ m}$ .

These values were then compared to the ranges of resistivities in the table and compacted clay and limestone were correctly selected as the materials in the soil.

This response scored 2 marks, MP1 and MP4.

(b) The table gives the resistivity of some different materials.

Material	Resistivity / $\Omega\text{m}$
Undisturbed clay	4–20
Compacted clay	100–200
Limestone	500–1000
Sandstone	1500–10 000

The probes connected to the voltmeter are kept at a constant separation of 0.75 m and are moved along the soil between positions A and D.

The current is constant at 9.5 mA. The voltmeter reading varies between 1.8 V and 8.0 V.

It can be assumed that the sample of soil under investigation has a cross-sectional area of  $0.65\text{ m}^2$ .

Deduce two possible materials that could be present in the soil between positions A and D.

$$R = \rho L / A \quad 9.5\text{ mA} = 9.5 \times 10^{-3}\text{ A} \quad (4)$$

$$R = V / I$$
$$1.8 \div 9.5 \times 10^{-3} = 189.47$$

$$8 \div 9.5 \times 10^{-3} = 842.1$$

$$R = \frac{189.47 \times 0.75}{0.65} = 218.6 \Omega\text{m}$$

$$R = \frac{842.1 \times 0.75}{0.65} = 971.65 \Omega\text{m}$$

Limestone and compacted clay.



Ohm's law has been used correctly to obtain a value for the resistance of the soil given the two voltmeter readings. An incorrect substitution was then made into the resistivity equation, with the length and area the wrong way round. Therefore the calculated values of resistivity are incorrect. The student however, still made a selection from the table based on their two incorrect resistivities and as their conclusion was consistent with these values they were able to score MP4.



Always write out an equation before you substitute into it and double check you have transferred it correctly from the list of equations at the back of the question paper.

The mark awarded is given is for a substitution into an equation, even if the quantity you are finding is not the subject of the equation. Therefore, if you make a mistake re-arranging the equation, you can still get credit for the substitution.

## **Question 14 (a)**

The vast majority of candidates attempted to determine the area under the curve to obtain a value for the total distance travelled. Incorrect methods seen involved calculating the area under the graph up to the current land speed record of  $341 \text{ m s}^{-1}$  while others carried out a simple  $d = v \times t$  calculation with the maximum velocity or 341. Although such methods were incorrect, students were still able to attain MP3 for a comparison of their distance to 23 km. Those who approximated the area under the graph to two triangles obtained a value greater than 23 km, but MP1 and MP3 could still be awarded for the method and the comparison.

Not all students that carved up the area under the graph into multiple regions obtained an answer in range, often due to an error in their arithmetic and sometimes as the consequence of the timing on the paper. Such precision was not required, two shapes i.e. a triangle and trapezium for each half was sufficient for an answer in range.

This response scored 1 mark, MP3.

- 14 The world land speed record of  $341 \text{ m s}^{-1}$  was set in October 1997. In an attempt to break this record, a new supersonic car has been developed called the Bloodhound.



The developers of the Bloodhound have used computer modelling to produce a velocity-time graph for the predicted motion of the car, on a straight track, during the record attempt.

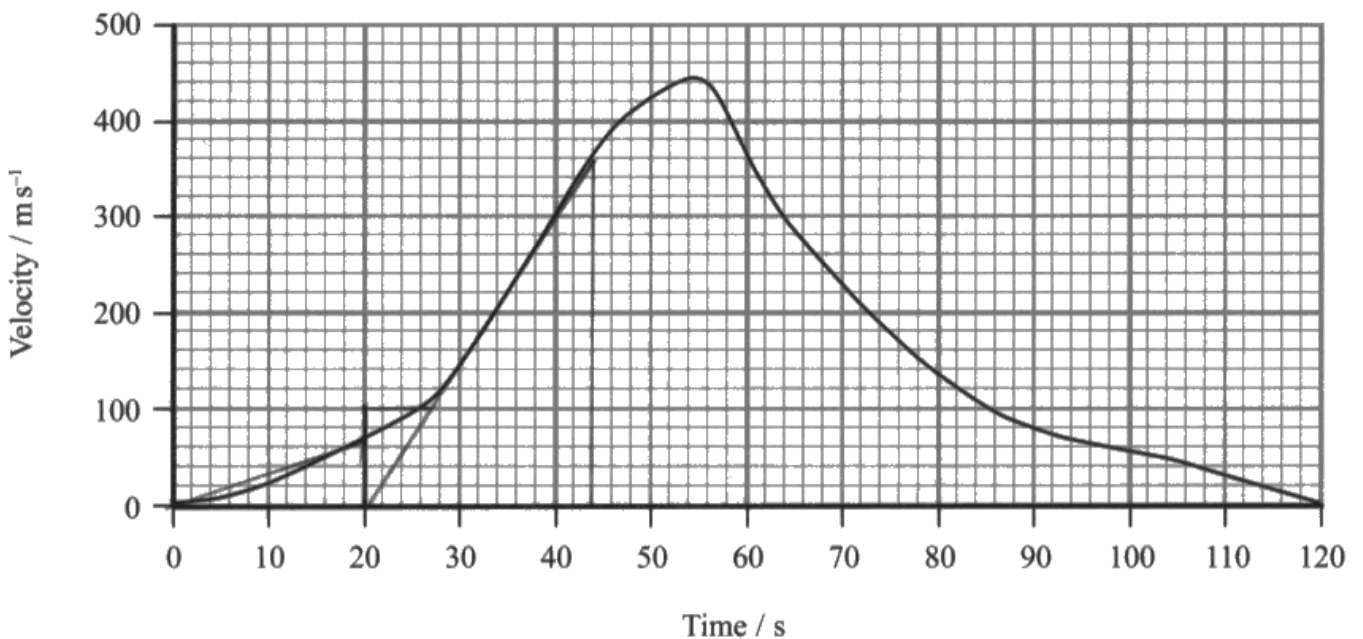

- (a) A track of length 23 km is available for the record attempt.

Determine whether this track is long enough.

(3)

$$v = 440 \text{ m s}^{-1} \quad t = 55 \text{ s}$$

$$s = vt = 440 \times 55$$

$$= 24200 \text{ m} = \underline{\underline{24.2 \text{ km}}}$$

The track of length 23 km is not long enough.



The student has only considered the motion of the car up to the maximum velocity and did not consider that the car would also require some track length for it to slow down in after reaching the maximum velocity.

$s = vt$  was used to calculate the distance, a formula which assumes that the velocity is constant so could not be credited as it does not correspond to an area under the graph.

The student however, did reach a conclusion consistent with their calculated track length so could be awarded MP3.

A good response scoring all 3 marks.

- 14 The world land speed record of  $341 \text{ m s}^{-1}$  was set in October 1997. In an attempt to break this record, a new supersonic car has been developed called the Bloodhound.



The developers of the Bloodhound have used computer modelling to produce a velocity-time graph for the predicted motion of the car, on a straight track, during the record attempt.

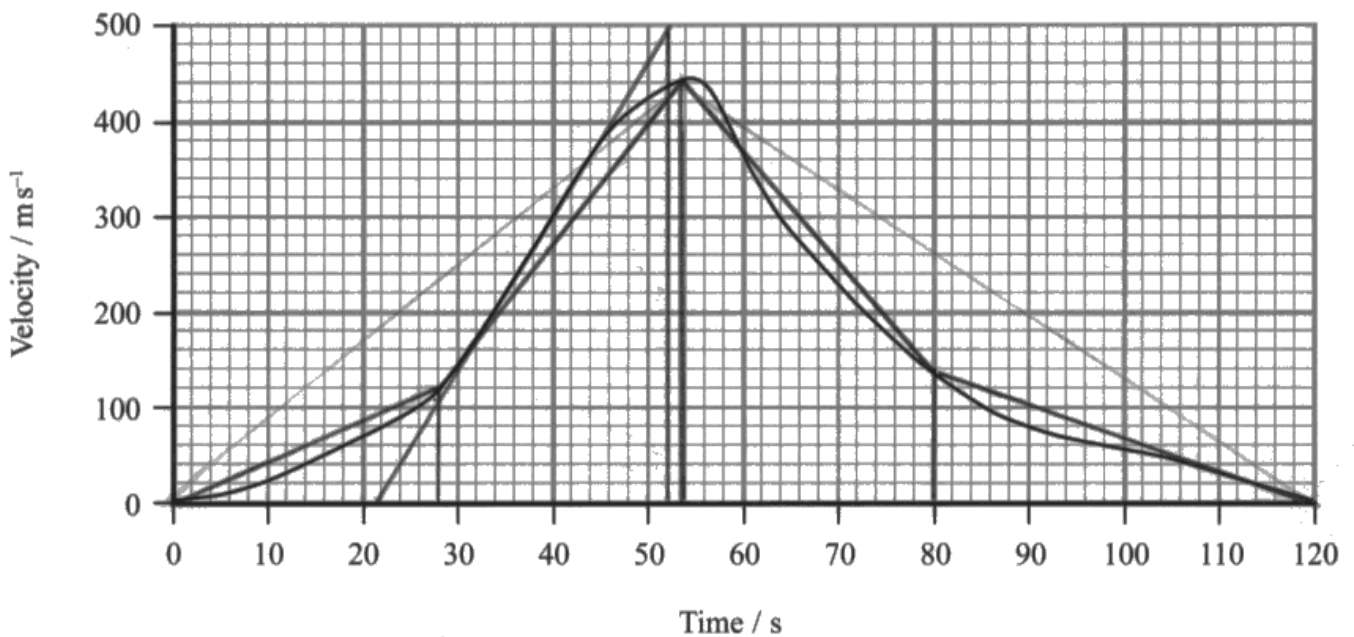

- (a) A track of length 23 km is available for the record attempt.

Determine whether this track is long enough.

(3)

$$s = \frac{1}{2}bh = \frac{1}{2}(120)(440)$$

$$s = \frac{1}{2}(28)(120) + \frac{1}{2}(440 + 120)(54 - 28)$$

$$+ \frac{1}{2}(440 + 140)(80 - 54) + \frac{1}{2}(120 - 80)(140)$$

$$= 1680 + 7280 + 87540 + 2800$$

$$= 19300 < 23000 \text{ m} \therefore \text{Yes, the track is long enough.}$$



The student divided up the region beneath the graph into a triangle and parallelogram for the acceleration and the same regions for the deceleration of the car.

This was probably the most efficient method time wise for obtaining a distance in range.

A distance of 19 300 m was obtained which was within the range stated on the mark scheme of 18 000 m to 20 000m. A conclusion was made that the track is long enough so all 3 marks were awarded.



This response scored 2 marks, MP1 and MP3.

- 14 The world land speed record of  $341 \text{ m s}^{-1}$  was set in October 1997. In an attempt to break this record, a new supersonic car has been developed called the Bloodhound.



The developers of the Bloodhound have used computer modelling to produce a velocity-time graph for the predicted motion of the car, on a straight track, during the record attempt.

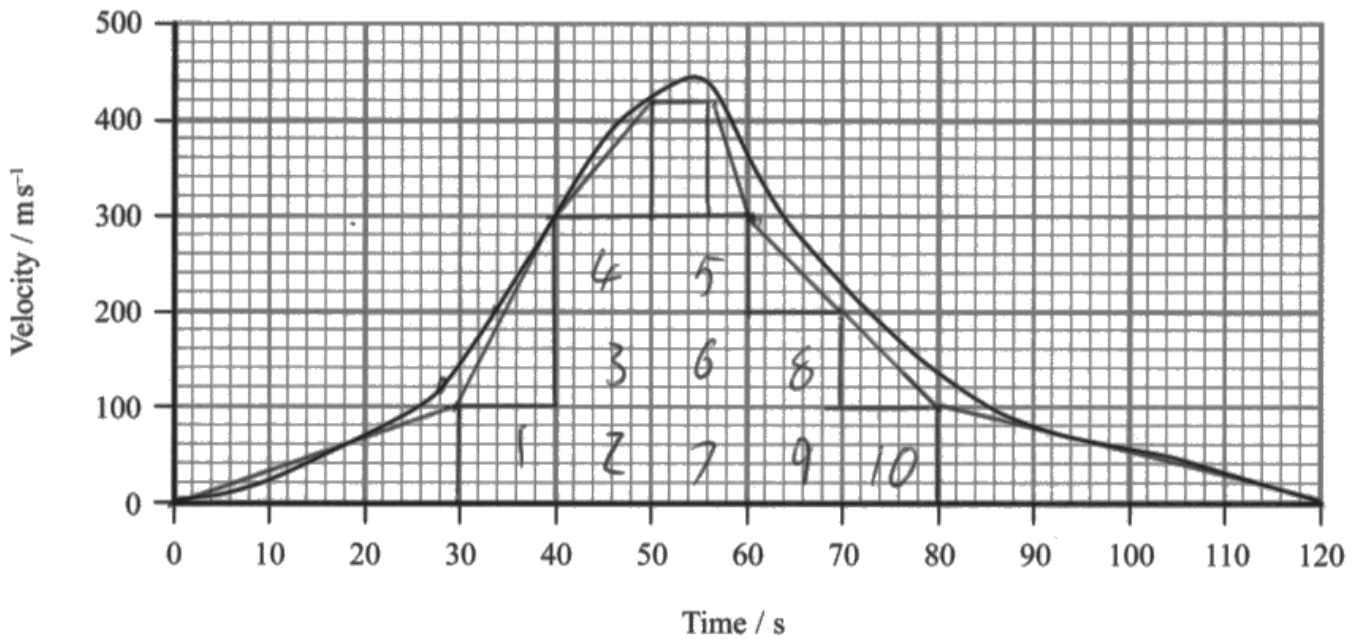

- (a) A track of length 23 km is available for the record attempt.

Determine whether this track is long enough.

(3)

$$\begin{aligned}
 & 10 \times 100 \times 10 + 30 \times 100 \times 0.5 + 0.5 \times 200 \times 10 \\
 & + 0.5 \times 120 \times 10 + 6 \times 120 + 0.5 \times 2 \\
 & \times 120 + 100 \times 10 + 0.5 \times 100 \times 40 \\
 & = 16.9 \text{ km}
 \end{aligned}$$

$\therefore$  Track is long enough as my estimate is much less than 23 km



The student has counted the large, 1 cm squares to determine the method, scoring MP1. Unfortunately, their method was too approximate and not enough squares were included in their calculation giving a distance just below the accepted range.

A conclusion was made however, that is consistent with their calculated value, so MP3 could be awarded.

## Question 14 (b) (i)

A straightforward question requiring the students to identify the instant at which the rocket engine was started, i.e. the instant at which there was a sudden increase in the acceleration.

Therefore, the vast majority of students successfully scored the mark by giving a number between 26 and 28. A number gave the time as 30s and a small number gave a time range from (0-)28-55s (misreading the question for the total time that the jet engine was running).

The most common incorrect answer was 55s, indicating a misreading of the question.

1 mark.

**(b) The car has two different engines: a jet engine providing a thrust of 89 kN and a rocket engine providing a thrust of 120 kN.**

**(i) The jet engine runs throughout the car's acceleration stage. The rocket engine runs for only part of that stage.**

**State the time at which the rocket engine is started during the car's predicted motion.**

**(1)**

26 seconds



A correct answer, in range, including the unit to score the mark.

## Question 14 (b) (ii) - (iii)

14(b)(ii) - The maximum positive acceleration occurred between 28s and 46s, therefore it was expected that the tangent of the graph would be taken in this region. The period of maximum acceleration produced a constant acceleration so the gradient of the linear part could be determined. Few drew a tangent onto the graph, enabling the most precise gradient to be obtained however, most that used the appropriate region of the graph and obtained an answer in range for the acceleration. Those that did not use an appropriate region of the graph were unable to score any marks, even if their answer, by coincidence, ended up being within the correct range.

14(b)(iii) – Most candidates realised that they would have to determine the resultant force using  $F = ma$  with their calculated acceleration from part (ii), scoring MP1. Many of these students assumed that  $ma$  was equal to the frictional force, ignoring any of the thrust forces provided by the engine and rocket. Therefore, a smaller number managed to obtain a correct expression for the resultant force i.e. thrust – frictional force to obtain a correct value for the frictional force. A correct expression for the resultant force, using the total forwards force, was required for MP2, and those who omitted either the force from the engine or the rocket force were unable to score this mark. Just a small number used  $9.81 \text{ m s}^{-2}$  for the acceleration, having no basis on which to select this value.

This response scored (b)(i) 2 marks and (b)(ii) 1 marks.

**14** The world land speed record of  $341 \text{ m s}^{-1}$  was set in October 1997. In an attempt to break this record, a new supersonic car has been developed called the Bloodhound.



The developers of the Bloodhound have used computer modelling to produce a velocity-time graph for the predicted motion of the car, on a straight track, during the record attempt.

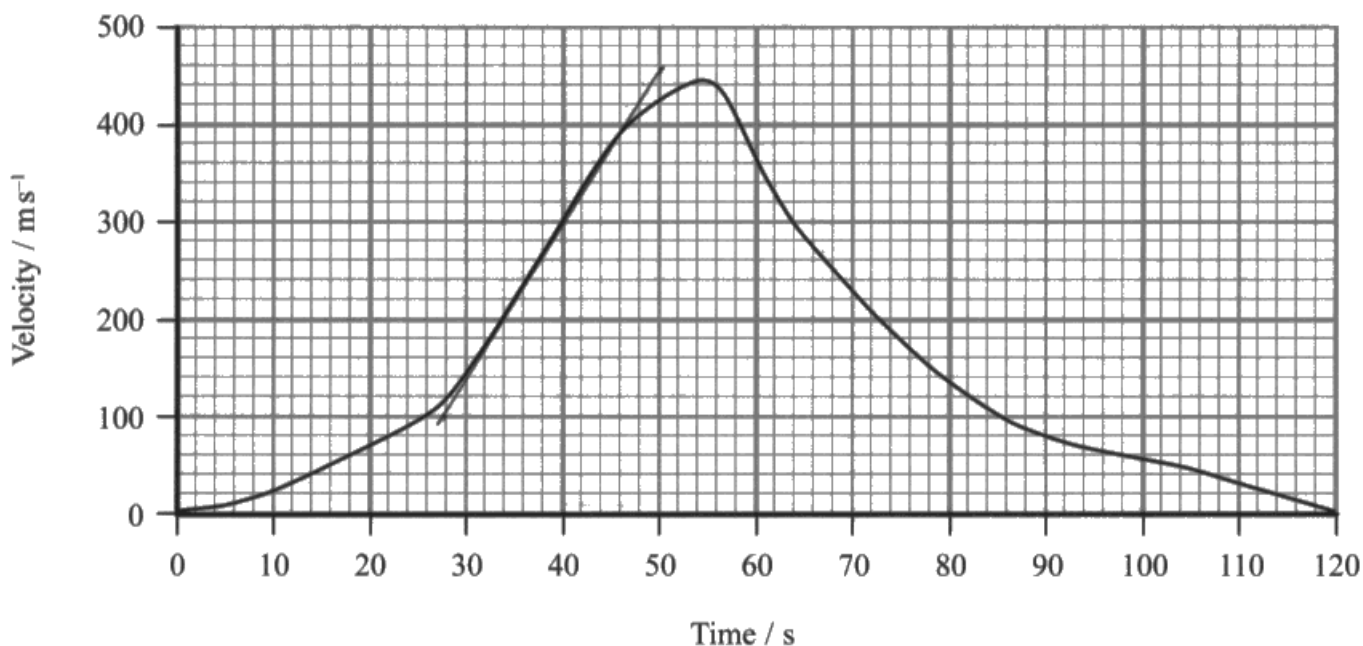

(ii) Use the graph to determine the maximum positive acceleration of the car.

(2)

$$50 - 28 = 22 \text{ s}$$

$$460 - 100 = 360 \text{ m s}^{-1}$$

$$\frac{360}{22} = 16.4 \text{ m s}^{-2}$$

Maximum positive acceleration of the car =  $16.4 \text{ m s}^{-2}$

(iii) Calculate a value for the frictional force acting on the car when the positive acceleration is a maximum.

(3)

mass of car including fuel at this time = 7790 kg

$$F = ma$$

$$7790 \times 16.4 = 127\,472.7 \text{ N}$$

$$127.5 \text{ kN}$$

Frictional force during maximum positive acceleration =  $127.5 \text{ kN}$



**ResultsPlus**  
Examiner Comments

(b)(i) The student drew a tangent onto the graph over the region of maximum acceleration and calculated a gradient of  $16.4 \text{ m s}^{-2}$  which was within the range stated in the mark scheme of  $16 - 17 \text{ m s}^{-2}$ , scoring both marks.

(b)(ii) Just MP1 for use of  $\Sigma F = ma$ . This was assumed to be the resultant force and no consideration was made as to the forces provided by the jet and rocket engines during this period of acceleration.



Consider all of the forces acting on an object when using  $\Sigma F = ma$ . The  $F$  is the resultant force and to have an acceleration in this case there must have been a force other than the frictional force acting on the car.

This response scored

(b)(i) 2 marks

(b)(ii) 3 marks.

**14** The world land speed record of  $341 \text{ m s}^{-1}$  was set in October 1997. In an attempt to break this record, a new supersonic car has been developed called the Bloodhound.



The developers of the Bloodhound have used computer modelling to produce a velocity-time graph for the predicted motion of the car, on a straight track, during the record attempt.

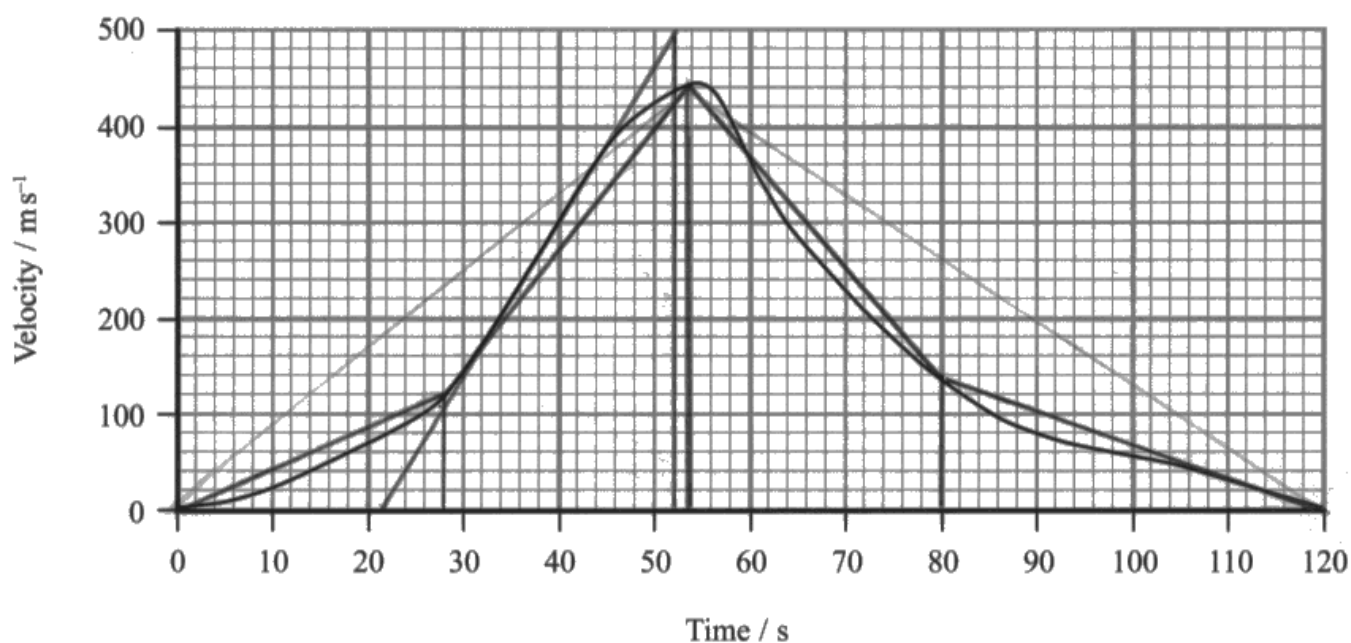

(ii) Use the graph to determine the maximum positive acceleration of the car.

(2)

$$a = \frac{\Delta v}{\Delta t} = \frac{500}{52-22} = \frac{500}{30} = 16.7 \text{ m s}^{-2}$$

Maximum positive acceleration of the car =  $16.7 \text{ m s}^{-2}$

(iii) Calculate a value for the frictional force acting on the car when the positive acceleration is a maximum.

(3)

mass of car including fuel at this time = 7790 kg

$$\sum F = ma$$

$$F - W = ma$$

$$F - (89 + 120) \times 10^3 = 7790 \times 16.7$$

$$F = 339093 \text{ N}$$

$$(89 + 120)(10^3) + F = 7790 \times 16.7$$

$$F = 79167 \text{ N}$$

Frictional force during maximum positive acceleration =

$$\begin{array}{l} \cancel{339 \text{ kN}} \\ 79.2 \text{ kN} \end{array}$$





This response is a good example of a response scoring full marks.

(b)(i) A tangent was drawn and an acceleration in range was determined scoring both marks.

(b)(ii) The student has remembered to include both the force from the rocket and from the jet engine when considering the resultant force acting on the car. All substitutions in to  $\Sigma F = ma$  were made correctly leading to a force of 79.2 kN.

This is slightly outside the range but is consistent with the value of acceleration calculated in part (ii) so full marks could be awarded.

This response scored (b)(i) 0 marks and (b)(ii) 1 mark.

- 14 The world land speed record of  $341 \text{ m s}^{-1}$  was set in October 1997. In an attempt to break this record, a new supersonic car has been developed called the Bloodhound.



The developers of the Bloodhound have used computer modelling to produce a velocity-time graph for the predicted motion of the car, on a straight track, during the record attempt.

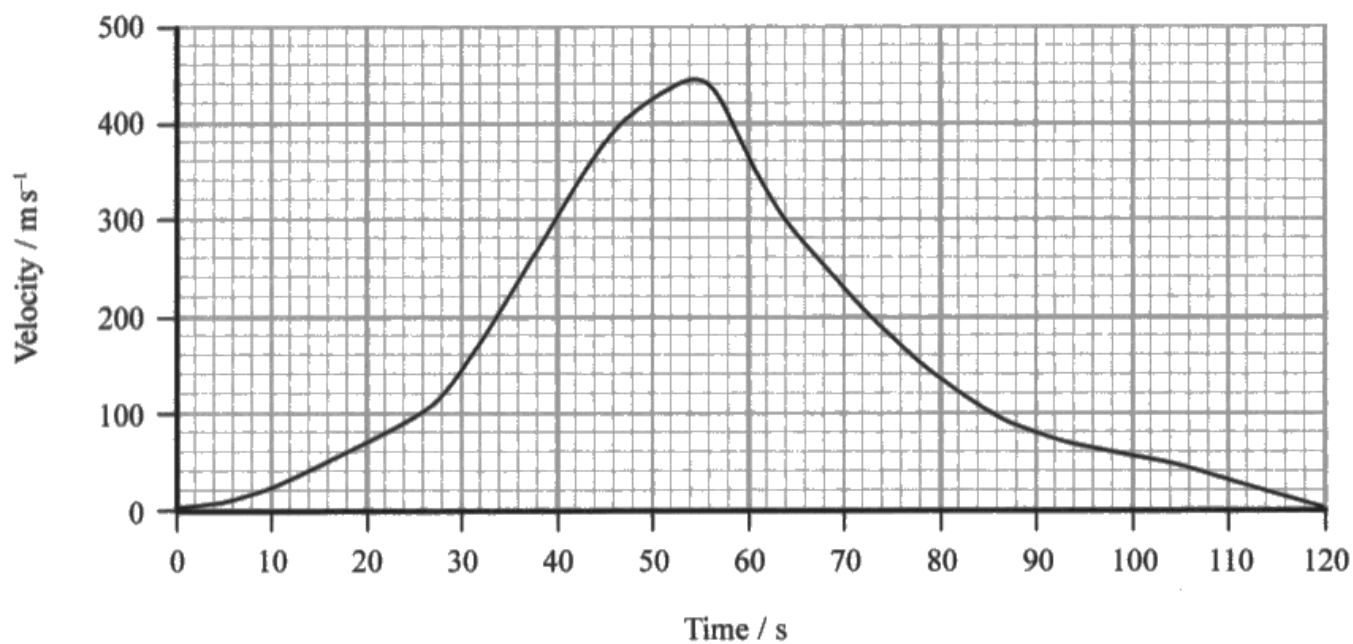

(ii) Use the graph to determine the maximum positive acceleration of the car.

(2)

$$v = u + at$$

$$\frac{440}{54} = 0 + \frac{54a}{54}$$

$$a = \underline{\underline{8.15 \text{ m/s}^2}}$$

Maximum positive acceleration of the car =  $\underline{\underline{8.15 \text{ m/s}^2}}$

(iii) Calculate a value for the frictional force acting on the car when the positive acceleration is a maximum.

(3)

mass of car including fuel at this time = 7790 kg

$$\text{Force} = \text{Mass} \times \text{Acceleration}$$

$$\text{force} = 7790 \times 8.15$$

$$\text{force} = \underline{\underline{63488.5 \text{ N}}}$$

Frictional force during maximum positive acceleration =  $\underline{\underline{63488.5 \text{ N}}}$



(b)(i) Rather than use a gradient to determine the maximum acceleration, the student has used  $v = u + at$ , an equation that assumes a constant acceleration. Therefore no credit could be given and no marks were awarded here.

(b)(ii) Just MP1 awarded for use of  $\Sigma F = ma$  to determine the resultant force.



Equations of motion can only be used where the acceleration is constant.

A velocity-time graph for a moving object, with changing gradients, will not have a constant acceleration and quantities relating to the motion of the object can only be determined using the graph i.e. area under the curve and gradient at an instant and not using equations of motion.

## Question 14 (c)

Question 14c required students to consider all of the forces that would act on the car and to explain how they could affect the acceleration and hence help to predict a velocity-time graph for the motion of the car. Many described the shape of the given velocity-time graph, without adding further explanation. Those who managed to identify a few of the factors, did not always link them to their effect on the motion, so the linkage marks were not awarded in many of the responses. The most common factor and linked explanation was to identify the increasing drag at higher velocities, reducing the acceleration. Some mentioned the increase force due to the addition of the rocket engine but did not go on to mention the subsequent increase in acceleration. A small number mentioned the decrease in mass, not always adding in that this would increase the acceleration. Only one mark was allocated to any description of the deceleration of the car. Many students assumed that the car would decelerate from its maximum velocity of  $440 \text{ m s}^{-1}$  solely due the air-resistance, without the aid of any braking mechanisms such as brakes or parachutes. Some good responses were seen though, where students described the drag forces decreasing at lower speeds causing a decrease in the deceleration.

The indicative content question in the paper is a requirement of this specification, combined with the use of the command word discuss. A discuss question requires the students to:

- Identify the issue/situation/problem/argument that is being assessed within the question
- Explore all aspects of an issue/situation/problem/argument
- Investigate the issue/situation etc by reasoning or argument

Based on students' responses to the question, additional practice based on unfamiliar contexts and styles of questioning is recommended for students to help with appreciating the requirements of this question type as well as in practice structuring longer answers.

This response scored 1 mark.

**\* (c) Discuss, with reference to the graph, the factors that would have been used to predict the motion of the car over the 120 s.**

(6)

Initially, the ~~remains~~ the graph is a curve. This is because the velocity will not increase linearly as work will be done against air resistance and as velocity increases, the force of drag on the car will increase. The graph is then linear as acceleration increases constantly for the car. A factor that would have affected the prediction of the motion is the amount of energy dissipated as heat by the car's engine and the amount of energy dissipated as sound. Another factor ~~that~~ that explains why the graph is a curve is the work done against the frictional force between the track and car's wheels.

(Total for Question 14 = 15 marks)



IC1 awarded for air resistance increases as velocity increases in lines 3-4.

No further indicative content points could be given according to the mark scheme.

So 1 indicative content = 1 mark. There is no linkage mark as only one correct Physics point was awarded so there is nothing to link this to.

This response scored 3 marks.

\*(c) Discuss, with reference to the graph, the factors that would have been used to predict the motion of the car over the 120 s.

(6)

Air resistance and drag would increase as velocity increased  
~~to~~ ∴ resultant force / acceleration would decrease. Turbulent  
flow would also decrease acceleration as resistance would  
increase ∴ the car should be streamlined to increase  
laminar flow. The mass of the car affects acceleration  
as  $F = ma$  ∴ the greater the mass, the lower the  
acceleration for a given force. Therefore the car should  
be light to increase acceleration. Other factors include the  
power of the engines - how much force is ~~app~~ applied  
per second.



IC1 - line 1 for air resistance and drag increase as velocity increased

IC2 - line 2 for resultant force decreases

Although the student has identified that the mass of the car will affect the acceleration, they have not implied that the mass will decrease due to the fuel being used.

IC5 was awarded though for making the link between a lighter car and a greater acceleration.

The other points mentioned are relevant but are not described using sufficient detail to score any more indicative content points.

The student linked together IC1 and IC2 so was awarded 1 linkage mark.

Therefore  $3 \times \text{IC} = 2$  marks plus  $+ 1 \times \text{linkage} = 3$  marks in total.

This question scored 5 marks. This is probably the minimum a student would have to write to be awarded 2 linkage and 4 indicative content points.

\*(c) Discuss, with reference to the graph, the factors that would have been used to predict the motion of the car over the 120 s.

(6)

To predict the motion of the car they would have:

- taken into consideration the air resistance and the frictional force, which increase as the car goes faster and ~~decrease~~ reduce the overall ~~cause it to decelerate~~ resultant force.
- the mass of the car decreasing as the fuel is burnt which makes the acceleration for ~~an equal~~ <sup>a constant</sup> resultant force bigger.
- the flow of air around the car, which was designed to be as aerodynamic as possible making the flow laminar and not turbulent, reducing friction. Viscous drag of air.
- the amount of fuel that could be stored in the car and burnt which would eventually run out causing the car to decelerate as can be seen from the decreasing section of the graph





IC1 - lines 2-3

IC2 - line 4

IC4 - line 5

IC5 - lines 6-7

The fourth bullet point is really only adding to the statement made earlier about the air resistance. As mentioned earlier, this student has assumed that it is the lack of fuel that caused the car to decelerate rather than an applied braking force.

As IC1 and 2 have been linked together along with IC4 and IC5 being linked together then both linkage marks were awarded.

4 x IC points = 3 marks + 2 x linkage = 5 marks in total.

## **Question 15 (a)**

This style of question has not been used before in the AS paper but similar questions have been asked on the International papers WPH03 and WPH06 which both could provide a source of practical based questions for students' to practice in preparation for this examination.

Most candidates could offer a sensible flaw with this method or suggest a suitable improvement, either of which were acceptable for the mark. The most common being that no repeat readings were taken.

The most common mistake was in relation to the number of decimal places and significant figures in the measurement of time and few identified that the number of significant figures for the microphone separation was inconsistent. Other common mistakes included stating that the units for time were incorrect i.e. 'should be seconds, not ms' or that the microphone-balloon distance should have been measured. A significant number of the candidates that were not awarded the mark often supplied a non-specific answer such as 'not enough readings were taken'. Thus being unclear as to whether they were referring to a greater range, smaller distance intervals or repeat readings.

This response did not score any marks.

- 15 A student carried out an experiment to determine the speed of sound in air. A short pulse of sound was produced by bursting a balloon near two microphones. The microphones were placed 1.00 m apart and connected to a computer.

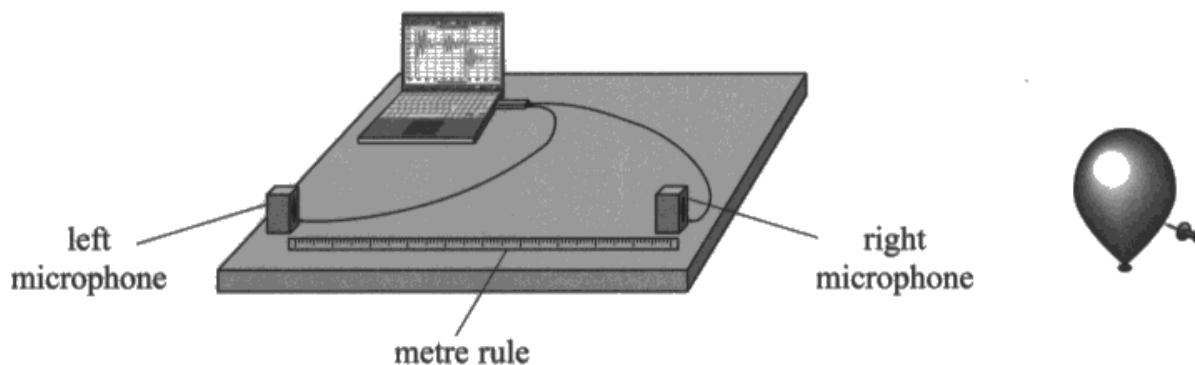

The computer was used to determine the time interval between the sound wave being received at the right microphone and being received at the left microphone.

The separation of the microphones was decreased several times and the corresponding time intervals recorded. The student obtained the following results.

Microphone separation / m	Time interval / ms
1.00	3.2
0.90	2.8
0.80	2.4
0.70	2.1
0.60	1.9
0.50	1.5

- (a) Criticise these results.

(1)

They have very few significant figures.



'Too few significant figures' as a response was not specific enough as two variables were being measured and neither has been referred to here. As a metre rule was used to measure the microphone separation, the measurements could have been quoted to an additional significant figure i.e. to the nearest mm or the student could have identified the inconsistency in the number of sf quoted for the separations. The time was already in milli seconds and was consistently recorded to 1 dp which is sufficient.

This response scored the mark.

- 15 A student carried out an experiment to determine the speed of sound in air. A short pulse of sound was produced by bursting a balloon near two microphones. The microphones were placed 1.00 m apart and connected to a computer.

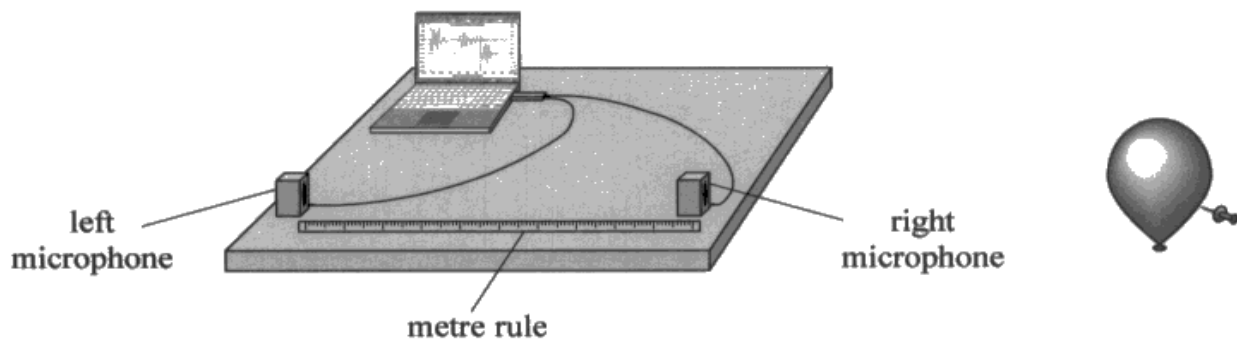

The computer was used to determine the time interval between the sound wave being received at the right microphone and being received at the left microphone.

The separation of the microphones was decreased several times and the corresponding time intervals recorded. The student obtained the following results.

Microphone separation / m	Time interval / ms
1.00	3.2
0.90	2.8
0.80	2.4
0.70	2.1
0.60	1.9
0.50	1.5

(a) Criticise these results.

(1)

*microphone separations intervals were too large.*



The difference between the microphone separations has correctly been identified as being too large.

A common response, scoring the mark.

- 15** A student carried out an experiment to determine the speed of sound in air. A short pulse of sound was produced by bursting a balloon near two microphones. The microphones were placed 1.00 m apart and connected to a computer.

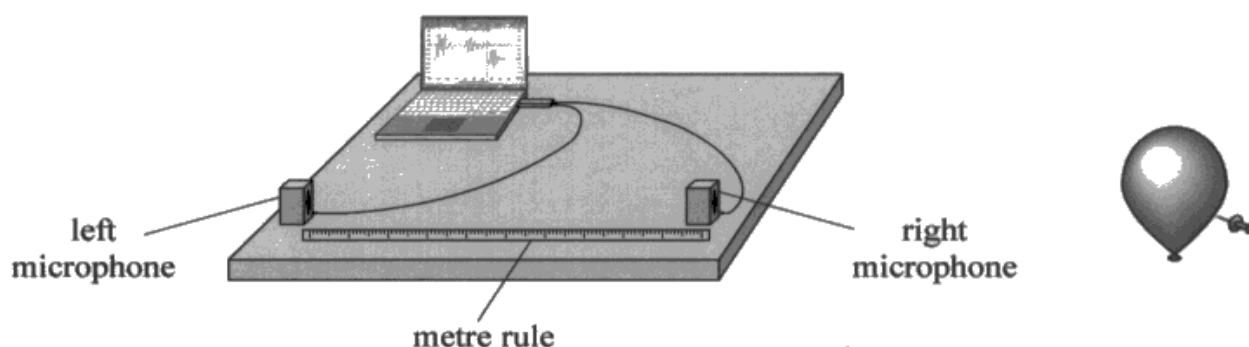

The computer was used to determine the time interval between the sound wave being received at the right microphone and being received at the left microphone.

The separation of the microphones was decreased several times and the corresponding time intervals recorded. The student obtained the following results.

Microphone separation / m	Time interval / ms
1.00	3.2
0.90	2.8
0.80	2.4
0.70	2.1
0.60	1.9
0.50	1.5

(a) Criticise these results.

(1)

They have not conducted any repeats.



'No repeats' was sufficient and candidates were not required to explain why, although many did, i.e. to calculate an average.

## Question 15 (b) - (c)

15(b)(i) - Students did not score as highly as they might have for this question. The mark scheme explains how the marks are awarded for the graph.

Axes labelled with quantities and units – the graph could be plotted either way round and, in general, most scored this mark.

Suitable scale – due to the numbers given, very few were not awarded this mark based on a scale going up in 3s. However, many missed out on this mark due to the amount of space used. It was expected that at least 50 % of the graph paper would be used in either direction. The graph did not need to pass through the origin and the axes should not have started from 0. Students should look ahead in such questions to see exactly what the required use is of the graph for. If it is just to determine a gradient, then the region over which the points are plotted is only required and this should be made as large as possible so as to make the gradient as accurate as possible.

Correct plotting – each point should be plotted as accurately as possible. Any point seen that is more than 1 small, 2mm square from its correct position will negate this marking point for the candidate. Points should also be visible. A small cross should be used and not a tiny dot which hard to identify once the line of best fit has been drawn over this or not too large a dot that makes the exact position of the point ambiguous.

Line of best fit – this will not necessarily fit through any of the points so candidates that connected the first and last dots would not have scored this mark. Examiners want to see an equal distribution of plotted points either side of the line of best fit producing the most accurate gradient for the scatter. Along with MP2, this was probably the least frequently awarded mark due to students not following these guidelines, particularly if they had drawn a larger scale, enlarging the spread of the plotted points.

15(b)(ii) – The candidates were required to use the graph to calculate value for speed of sound. Candidates that had plotted a graph of microphone separation against time interval were able to take a direct reading of the gradient and obtain a value for the speed of sound. Not all students that plotted the graph the other way round realised that an inverse of the gradient would be required. Given that the inverse of the gradient was about 300, many accepted this as a correct method for the speed of sound without realising their error.

The range of acceptable answers for the speed of sound was from 280 to 310 m s<sup>-1</sup>. 310 m s<sup>-1</sup> being towards the more accurate end of the range. Students were seen to use given points rather than actual point sitting on the line of best fit to calculate the gradient. Any points used in the working were checked against the line of best fit and again, as with the plotting, if these were more than half a small square away from the, the method was deemed invalid. Given that many of the graphs scales did not go down to 0 students seem to have forgotten this and off and picked a point on the line and calculated a ratio of the two points as their gradient without realising that the graph needs to pass through the origin in order for this method to work. Again, as with graph plotting, practice would be beneficial to students, particularly in cases where there are some scatter and when there is not an origin included in the scale.

15(c) – This question required a comment on the calculated value of the speed of sound along with two possible reasons for the difference between the calculated and actual value. Students were given the actual value the speed of sound, really more to direct them towards making a comparison of the two values. Comments describing their calculated speed and how far it was from the true value without stating whether it was higher or lower than the true value was not sufficient for MP1. Other students failed to make any comparison between the values at all. The positioning of the

balloon or lack of repeats were the most commonly seen responses that did not score. The most common sensible suggestion was parallax when reading from the rule. Very few commented on the very small time involved and hence the large percentage uncertainty. Given that this is a practical question the first two marking points for the small time and percentage error i.e. measured times are small and large percentage uncertainty really should have been the two most common answers.



This response scored (b)(i) 3 (b)(ii) 2 (c) 2.

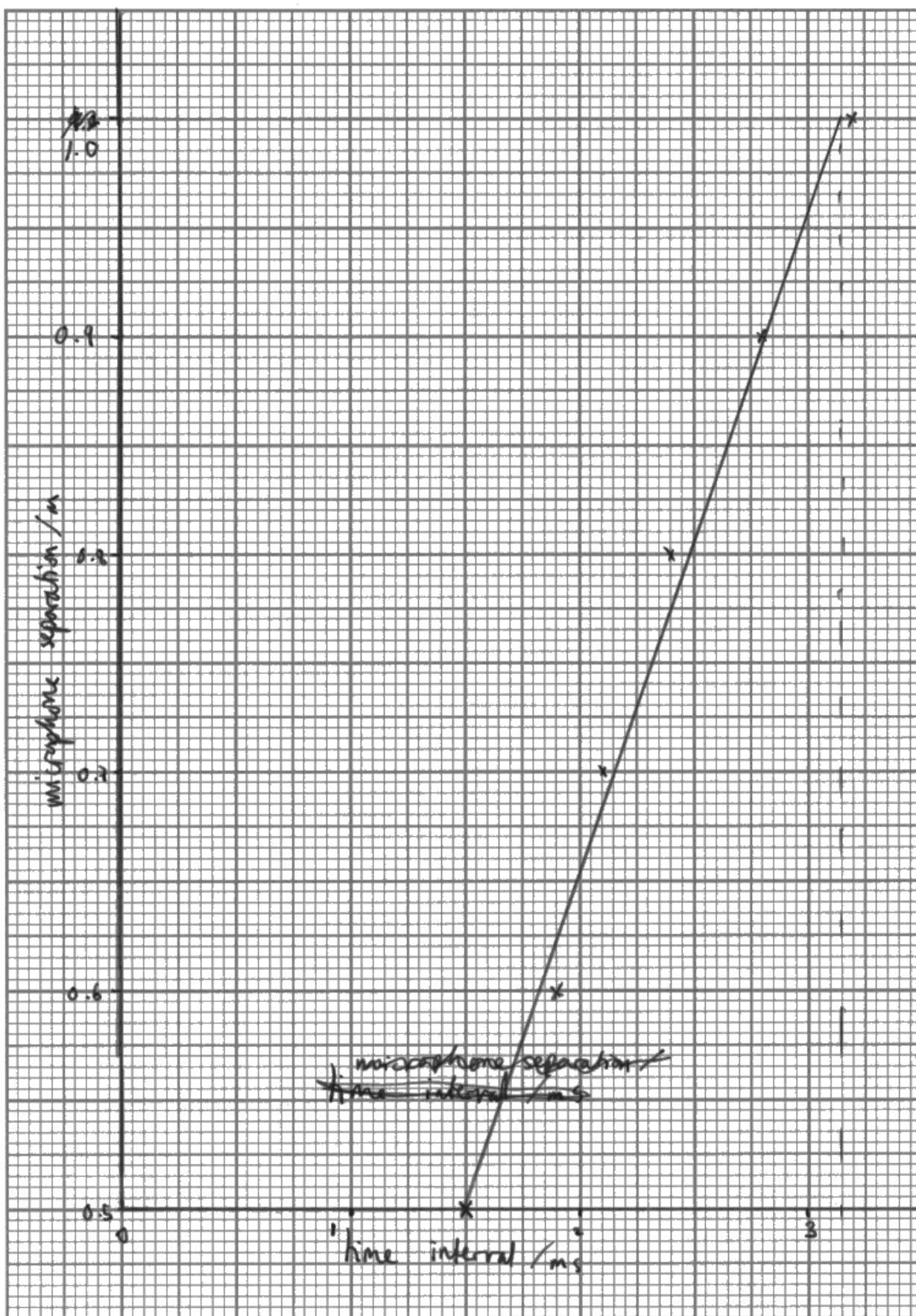

(ii) Determine a value for the speed of sound in air.

(2)

$$3.15 - 1.5 \\ = 1.65 \text{ ms}$$

$$\frac{0.5}{3.15 \text{ ms}} =$$

$$\frac{0.5}{1.65 \times 10^{-3}} = 303 \text{ ms}^{-1}$$

$$\text{Speed of sound in air} = 303 \text{ ms}^{-1}$$

(c) The actual speed of sound in air is  $330 \text{ ms}^{-1}$ .

Comment on the value for the speed of sound in air at this temperature obtained from the student's results, referring to any possible sources of error.

(3)

This value is lower than the speed of sound. Sound requires a medium to travel through, denser the medium faster sound travel. Air becomes less dense as it gets hotter so the temperature may have been higher. There might be a zero error on the computer so all values are slightly out. There could be a parallax error when reading the distance on the ruler. Distance may be measured from back of microphone

(b)(i) The axes have been labelled correctly so MP1 awarded. The scale for the time axis could have been doubled so MP2 was not awarded as the plotted points do not quite cover 50% of the graph paper horizontally. All 6 points have been plotted correctly (MP3) and although the line of best fit is not quite steep enough the line is acceptable (MP4).

(b)(ii) A large triangle has been used to determine the gradient and values taken are from the line of best fit. This has led to a gradient of  $303 \text{ m s}^{-1}$  which is in range so full marks for the graph.

(c) A comparison has been made between the calculated value and the true value for the speed of sound (MP1) with a reference to parallax when reading from the rule (MP2) scored 2 marks in part (c). No credit was given to references to temperature as over the short period of the experiment, any fluctuations in temperature would not have been so significant so as to cause such a difference between the two values.

This response scored (b)(i) 3 (b)(ii) 2 (c) 1.

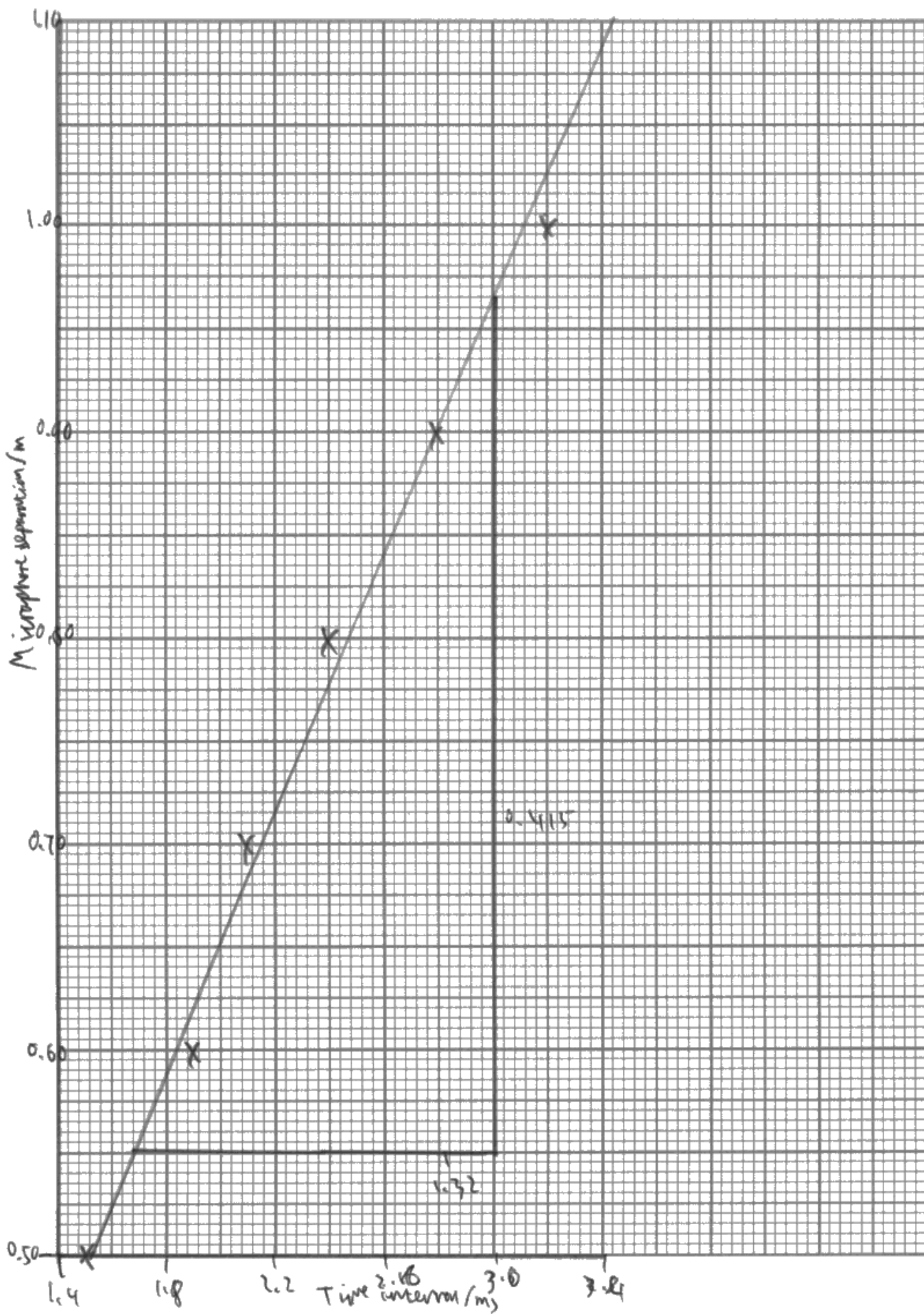

(ii) Determine a value for the speed of sound in air.

(2)

$$\frac{0.415}{1.29410} = 310 \text{ m s}^{-1} \text{ (2 s.f.)}$$

Speed of sound in air =  $310 \text{ m s}^{-1}$

(c) The actual speed of sound in air is  $330 \text{ m s}^{-1}$ .

Comment on the value for the speed of sound in air at this temperature obtained from the student's results, referring to any possible sources of error.

(3)

The student's error was likely due to the measurement of the time interval, with a  $0.1 \text{ m s}$  uncertainty on results as small as  $1.5 \text{ m s}$  (up to a 7% error margin), leading to an inaccurate value of the speed of sound being calculated. ~~It would~~ There would also have been an error in the measurement of the distance between the microphones, although this would have been far smaller (between 0% uncertainty in  $0.50 \text{ m}$  to 1% uncertainty in  $1.00 \text{ m}$ ).



(b)(i) Both axes labelled correctly (MP1) with a scale that goes up with each small 2mm square in 0.4s, a scale that is not permitted (a scale may only go up in multiples of 1,2,5) so no MP2. Points plotted correctly (MP3) and a suitable line of best fit (MP4).

(b)(ii) A large triangle has been used to determine the gradient obtaining a value in range of  $310 \text{ m s}^{-1}$  so full marks.

(c) MP2 only for the idea that there is a large percentage uncertainty in the measured time; this was shown through a calculation and such a method was sufficient for MP2.

## Question 16 (a) (i)

Question 16 was the synoptic question drawing on aspects of light waves from unit two along with aspects of electricity from unit one . 16(a)(i) required candidates to give a standard definition of what polarisation is of plane polarised light. This appeared many times on the previous specification and candidates did not always successfully define plane polarisation. Those that attempted the description in terms of direction but generally more successful is picking up both marks. Those describing the oscillations in one plane only were not as precise enough in their explanation of this plane including the direction of energy transfer of and confusing this and discussing this in terms of the plane including perpendicular to the direction of energy transfer.

A good response scoring both marks.

**16** A liquid-crystal display uses a series of segments to form letters and numbers on a screen.

(a) The construction of a display segment is shown.

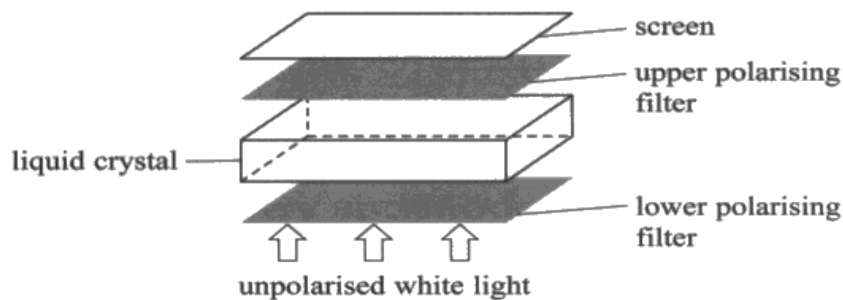

- Unpolarised white light passes through the lower polarising filter and becomes plane polarised.
- When there is no potential difference (p.d.) across the liquid crystal, the molecules in the liquid crystal rotate the plane of polarisation by  $90^\circ$ .
- Light then passes through the upper polarising filter and appears on the screen.
- When a p.d. is applied across the liquid crystal, the molecules no longer rotate the plane of polarisation. The light will not pass through the upper polarising filter and the screen appears dark.

(i) Describe what is meant by plane polarised light.

light waves that only consist of oscillations<sup>(2)</sup> in a single plane (including direction of energy transfer)



A clear answer including a reference to the oscillations in a single plane and a reference to the direction of the energy transfer of travel.

An incomplete response scoring just 1 mark.

**16** A liquid-crystal display uses a series of segments to form letters and numbers on a screen.

(a) The construction of a display segment is shown.

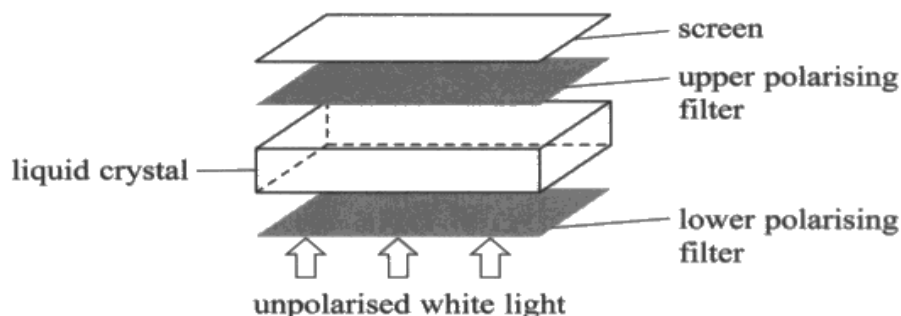

- Unpolarised white light passes through the lower polarising filter and becomes plane polarised.
- When there is no potential difference (p.d.) across the liquid crystal, the molecules in the liquid crystal rotate the plane of polarisation by  $90^\circ$ .
- Light then passes through the upper polarising filter and appears on the screen.
- When a p.d. is applied across the liquid crystal, the molecules no longer rotate the plane of polarisation. The light will not pass through the upper polarising filter and the screen appears dark.

(i) Describe what is meant by plane polarised light.

(2)

Light that is forced to oscillate  
in only one plane.



Just MP1 awarded for a reference to the oscillations being in only one plane. No comment was made as to the direction of the energy transfer or travel etc.

This response did not score any marks.

**16** A liquid-crystal display uses a series of segments to form letters and numbers on a screen.

(a) The construction of a display segment is shown.

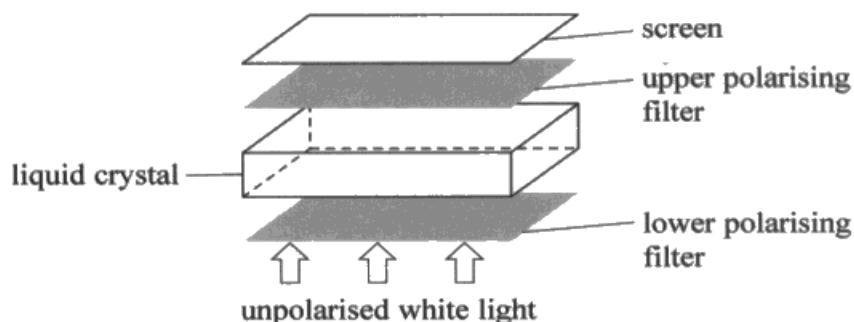

- Unpolarised white light passes through the lower polarising filter and becomes plane polarised.
- When there is no potential difference (p.d.) across the liquid crystal, the molecules in the liquid crystal rotate the plane of polarisation by  $90^\circ$ .
- Light then passes through the upper polarising filter and appears on the screen.
- When a p.d. is applied across the liquid crystal, the molecules no longer rotate the plane of polarisation. The light will not pass through the upper polarising filter and the screen appears dark.

(i) Describe what is meant by plane polarised light.

light that only travels in one direction, meaning it either has a horizontal component or a vertical, as it will have both. <sup>(2)</sup>



No reference has been made to oscillations so MP1 could not be awarded.

In addition to this, no reference has been made to the direction of energy transfer or travel of the wave.



## Question 16 (a) (ii)

16(a)(ii) required the students to have processed the context by reading the four bullet points given at the beginning of the questions thoroughly. This was answered well with many candidates appreciating that the crystal rotated the light by  $90^\circ$  when no p.d. was applied and therefore the two polarising filters needed to be perpendicular to each other in order to let the light through. Only a small number of students discussed continually rotating screens and did not appreciate the purpose of the crystal.

This response scored 1 mark.

- (ii) Explain the angle of polarisation of the upper polarising filter relative to the lower polarising filter.

they are  $90^\circ$  <sup>difference</sup> ~~to each other~~ as the polarised (2)  
light only passes through one of them then all  
the light is perpendicular to the other plane so  
no light is shown on the screen.



The student has described the angle of polarisation of the upper filter to the lower filter as  $90^\circ$ . They have not mentioned the crystal or that fact that there is a p.d. so the crystal does not rotate the light, making the screen appear dark. Therefore only MP1 could be awarded.

This response scored 0 marks.

- (ii) Explain the angle of polarisation of the upper polarising filter relative to the lower polarising filter.

o It will be in the same plane as the lower polarising filter <sup>(2)</sup>  
so ~~at~~ ~~light~~ light can pass through it and not be absorbed.



This student has not understood the purpose of the filter and has just assumed that the polarising filters should lie in the same plane, i.e. a polarising angle of  $0^\circ$  or  $180^\circ$  etc to let any light pass through the upper filter. Therefore no marks could be awarded.

This response scored both marks.

- (ii) Explain the angle of polarisation of the upper polarising filter relative to the lower polarising filter.

the upper filter is at  $90^\circ$  to the lower filter <sup>(2)</sup>  
as when the ~~light~~ plane of polarisation isn't  
rotated ~~no~~ (p.d. applied) not light gets through  
 $\therefore$  filters must be perpendicular to each other.



$90^\circ$  has been stated as the angle of polarisation of the upper to the lower polarising filter scoring MP1.

The student has also correctly described the condition where light is not rotated as there is no applied p.d. across the crystal, hence light cannot get through the the upper filter, scoring MP2.

## Question 16 (b)

Question 16(b) was carried out successfully by nearly all candidates, with most scoring full marks on both these items. The vast majority were able to use equation for intensity to obtain a power of 0.014 W in (b)(i) and then go on in part (b)(ii) to use this value with the calculated output power of 0.072 W to determine the efficiency of the power output of the LED.

This response scored full marks, (b)(i) 2 marks and (b)(ii) 3 marks.

- (b) (i) The intensity of the emitted light at the surface of a display segment is  $7.8 \text{ W m}^{-2}$ .  
The segment has an exposed area of  $1.8 \times 10^{-3} \text{ m}^2$ .

Calculate the power of the emitted light at the surface of the display segment.

(2)

$$I = P/A$$

$$I \times A = P$$

$$7.8 \times 1.8 \times 10^{-3} = 0.01404 \text{ W}$$

2 sig fig

$$\text{Power of emitted light} = 0.014 \text{ W}$$

- (ii) A light-emitting diode (LED) is used to provide the unpolarised white light for the liquid-crystal display.

Calculate the efficiency of the liquid-crystal display segment.

(3)

current in LED = 20 mA

p.d. across LED = 3.6 V

P, I, V

$$P = VI \quad P = 20 \times 10^{-3} \times 3.6 \quad P = 0.072 \text{ W}$$

$$\frac{0.014}{0.072} \times 100\% = 19.44\%$$

$$\text{Efficiency of liquid-crystal display segment} = 19.4\%$$



(b)(i) Intensity = power/area used correctly to determine the power of the emitted light.

(b)(ii)  $P = VI$  used correctly to determine the input power of the LED of 0.072 W, followed by successful use of the efficiency equation, obtaining an efficiency of 19.4 %.

This response scored (b)(i) 1 mark and (b)(ii) 2 marks.

- (b) (i) The intensity of the emitted light at the surface of a display segment is  $7.8 \text{ W m}^{-2}$ .  
The segment has an exposed area of  $1.8 \times 10^{-3} \text{ m}^2$ .

Calculate the power of the emitted light at the surface of the display segment.

(2)

$$I = \frac{P}{A}$$

$$P = IA$$

$$7.8 \times (1.8 \times 10^{-3}) = 0.01404$$

Power of emitted light = ~~0.01404~~ 0.014

- (ii) A light-emitting diode (LED) is used to provide the unpolarised white light for the liquid-crystal display.

Calculate the efficiency of the liquid-crystal display segment.

(3)

current in LED = 20 mA

p.d. across LED = 3.6 V

$$P = IV \quad (20 \times 10^{-3} \text{ A})(3.6 \text{ V}) = 0.72$$

$$\frac{0.014}{0.72} \times 100 = 1.94\%$$

Efficiency of liquid-crystal display segment = ~~1.94%~~ 1.9%

(2 s.f.)



(b)(i) Correct calculation and answer but the unit is missing so just MP1 awarded.

(b)(ii) Although the equation  $P = VI$  has been used correctly, they has been a power of 10 error and the answer of 0.72 for the power is incorrect. This value was then used correctly in the equation for efficiency. Therefore, two use of marks, MP1 and MP2 can still be awarded but not the final answer mark.

## **Question 16 (c)**

Question 16(c) was not answered as expected by students. This question required the students to analyse the given stress-strain graph for the two materials and then apply this to the context. It was made clear in the stem of the question that these were not the graphs to breaking point, only the graphs over the range of stresses that the screen would be under in normal use.

Good answers identified the difference in the Young moduli of materials X and Y and could make a sensible statement that Y was more suitable as it had a lower Young modulus and therefore would be more flexible. MP3 and MP4 were therefore the most commonly awarded marks. MP1 and MP2 required the students to think about the behaviour of the materials beyond everyday use, using larger stresses, for example if the screen is dropped or is under a lot of stress. Therefore, any reference to brittle behaviour or a large plastic material for why would not score the marks unless it was clearly identified at greater stresses.

Many did not look at the actual scaling height of either line as they both went up to the same maximum stress therefore comments such as a greater maximum stress, which could not be determined from the given graph, were inappropriate and not credited.

This response scored 2 marks.

- (c) Manufacturers are developing new materials for flexible screens for liquid-crystal displays. The graph shows how stress varies with strain for two materials X and Y up to typical stresses that would be applied to the screens in normal use. Both materials behave elastically over the ranges shown.

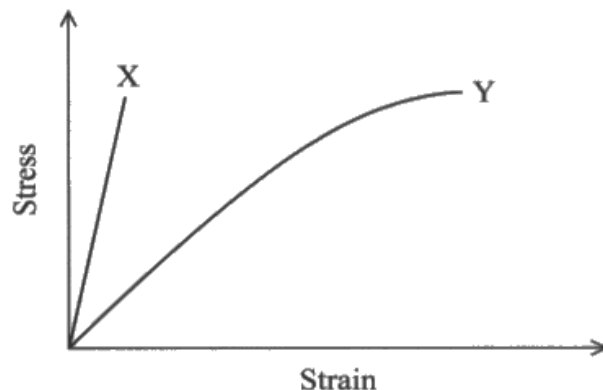

Deduce which material would be more suitable to use for the flexible screen in liquid-crystal displays.

(4)

$$\text{Stress} = \frac{F}{A}$$

$$\text{Strain} = \frac{\Delta x}{x} = \% \text{ extension}$$

Material X has high stress but low strain meaning it is very strong, but has little flexibility. Whereas Material Y has high stress & high strain, so it is very strong but also flexible at the same time. ~~B~~ So manufacturer should use Material Y

Material Y has low Young's Modulus  
Material X has high Young's Modulus

(Total for Question 16 = 13 marks)



MP3 and 4 awarded for a correct comparison of the Young Moduli of X and Y (MP3) in the last 2 lines.

MP4 awarded for a correct conclusion that Y is more suitable with the idea that it is more flexible.

This response scored 3 marks.

- (c) Manufacturers are developing new materials for flexible screens for liquid-crystal displays. The graph shows how stress varies with strain for two materials X and Y up to typical stresses that would be applied to the screens in normal use. Both materials behave elastically over the ranges shown.

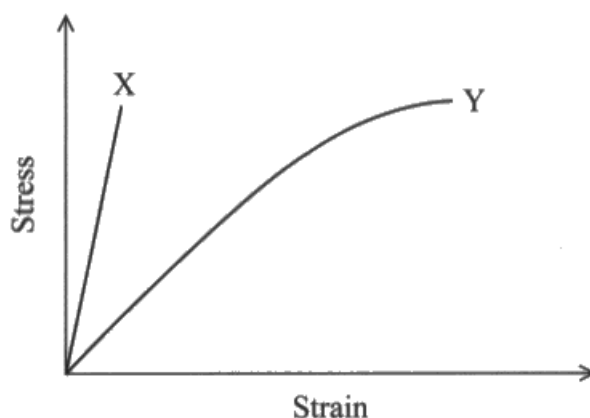

Deduce which material would be more suitable to use for the flexible screen in liquid-crystal displays.

(4)  
material Y as it has a lower young's modulus and so shows more strain for the same stress and is therefore more flexible. ~~however material X has a higher limit of proportionality and so would not show permanent deformation at normal~~ Both X and Y behave elastically at stresses higher than normal use so neither would show permanent deformation. X is more rigid and brittle than Y



MP3 and MP4 were awarded for the first three lines where the student has identified that Y is more suitable as it is more flexible and has a greater Young modulus.

The student has ventured into a discussion of the behaviour of X and Y at greater stresses, identifying that X is more brittle than Y which is MP1. Unfortunately they incorrectly stated that neither would show permanent defination at these greater stress which is not the case for material Y.

## Paper Summary

This paper provided students with a wide range of contexts from which their knowledge and understanding of the physics contained within this unit could be tested.

A sound knowledge of the subject was evident for many but the responses seen did not reflect this as the language lacked precision and its ambiguity prevented some marks from being awarded.

Based on their performance on this paper, candidates are offered the following advice:

- Slow down during the multiple choice items so that key words or directions in the command sentence responses are not missed however, do not spend a disproportionate amount of time on these questions as you may run out of time towards the end of the paper.
- Do not quote laws and principles. If a question requires you to use them then apply them to the context of the question as part of your answer.
- When plotting graphs your plots must use at least 50 % of the graph paper in either direction so make sure your scale is large enough.
- When using a graph to determine a gradient, the points taken for the gradient must actually sit on your line of best fit. If a plotted point does not sit on the line of best fit then it should not be one of the points you use for the gradient.
- Practice calculations using potential dividers as well resistors in parallel and series as seen in Q9b. Just knowing how to substitute values into Ohm's law and the formulae for the total resistance in series and parallel is not sufficient revision.

## Grade Boundaries

Grade boundaries for this, and all other papers, can be found on the website on this link:

<http://www.edexcel.com/iwantto/Pages/grade-boundaries.aspx>



