

Mark Scheme (FINAL)

Summer 2008

GCE

GCE Physics (6732/01)

General Marking Guidance

- All candidates must receive the same treatment. Examiners must mark the first candidate in exactly the same way as they mark the last.
- Mark schemes should be applied positively. Candidates must be rewarded for what they have shown they can do rather than penalised for omissions.
- Examiners should mark according to the mark scheme not according to their perception of where the grade boundaries may lie.
- There is no ceiling on achievement. All marks on the mark scheme should be used appropriately.
- All the marks on the mark scheme are designed to be awarded. Examiners should always award full marks if deserved, i.e. if the answer matches the mark scheme. Examiners should also be prepared to award zero marks if the candidate's response is not worthy of credit according to the mark scheme.
- Where some judgement is required, mark schemes will provide the principles by which marks will be awarded and exemplification may be limited.
- When examiners are in doubt regarding the application of the mark scheme to a candidate's response, the team leader must be consulted.
- Crossed out work should be marked UNLESS the candidate has replaced it with an alternative response.

Mark scheme notes

Underlying principle

The mark scheme will clearly indicate the concept that is being rewarded, backed up by examples. It is not a set of model answers.

For example:

(iii) Horizontal force of hinge on table top

66.3 (N) or 66 (N) **and** correct indication of direction [no ue] ✓ 1
[Some examples of direction: acting from right (to left) / to the left / West / opposite direction to horizontal. May show direction by arrow. Do not accept a minus sign in front of number as direction.]

This has a clear statement of the principle for awarding the mark, supported by some examples illustrating acceptable boundaries.

1. Mark scheme format

- 1.1 You will not see 'wtte' (words to that effect). Alternative correct wording should be credited in every answer unless the ms has specified specific words that must be present. Such words will be indicated by underlining e.g. 'resonance'
- 1.2 Bold lower case will be used for emphasis.
- 1.3 Round brackets () indicate words that are not essential e.g. "(hence) distance is increased".
- 1.4 Square brackets [] indicate advice to examiners or examples e.g. [Do not accept gravity] [ecf].

2. Unit error penalties

- 2.1 A separate mark is not usually given for a unit but a missing or incorrect unit will normally cause the final calculation mark to be lost.
- 2.2 Incorrect use of case e.g. 'Watt' or 'w' will **not** be penalised.
- 2.3 There will be no unit penalty applied in 'show that' questions or in any other question where the units to be used have been given.
- 2.4 The same missing or incorrect unit will not be penalised more than once within one question but may be penalised again in another question.
- 2.5 Occasionally, it may be decided not to penalise a missing or incorrect unit e.g. the candidate may be calculating the gradient of a graph, resulting in a unit that is not one that should be known and is complex.
- 2.6 The mark scheme will indicate if no unit error penalty is to be applied by means of [no ue].

3. Significant figures

- 3.1 Use of an inappropriate number of significant figures in the theory papers will normally only be penalised in 'show that' questions where use of too few significant figures has resulted in the candidate not demonstrating the validity of the given answer.
- 3.2 Use of an inappropriate number of significant figures will normally be penalised in the practical examinations or coursework.
- 3.3 Using $g = 10 \text{ m s}^{-2}$ will **not** be penalised.

4. Calculations

- 4.1 Bald (i.e. no working shown) correct answers score full marks unless in a 'show that' question.
- 4.2 If a 'show that' question is worth 2 marks then both marks will be available for a reverse working; if it is worth 3 marks then only 2 will be available.
- 4.3 **use** of the formula means that the candidate demonstrates substitution of physically correct values, although there may be conversion errors e.g. power of 10 error.
- 4.4 **recall** of the correct formula will be awarded when the formula is seen or implied by substitution.
- 4.5 The mark scheme will show a correctly worked answer for illustration only.
- 4.6 Example of mark scheme for a calculation:

'Show that' calculation of weight

Use of $L \times W \times H$	✓
Substitution into density equation with a volume and density	✓
Correct answer [49.4 (N)] to at least 3 sig fig. [No ue] [Allow 50.4(N) for answer if 10 N/kg used for g.] [If 5040 g rounded to 5000 g or 5 kg, do not give 3 rd mark; if conversion to kg is omitted and then answer fudged, do not give 3 rd mark] [Bald answer scores 0, reverse calculation 2/3]	✓

3

Example of answer:

$$80 \text{ cm} \times 50 \text{ cm} \times 1.8 \text{ cm} = 7200 \text{ cm}^3$$

$$7200 \text{ cm}^3 \times 0.70 \text{ g cm}^{-3} = 5040 \text{ g}$$

$$5040 \times 10^{-3} \text{ kg} \times 9.81 \text{ N/kg}$$

$$= 49.4 \text{ N}$$

5. Quality of Written Communication

- 5.1 Indicated by QoWC in mark scheme, placed as first mark.
- 5.2 Usually it is part of a max mark.
- 5.3 In SHAP marks for this are allocated in coursework only but this does not negate the need for candidates to express themselves clearly, using appropriate physics terms. Likewise in the Edexcel A papers.

6. Graphs

- 6.1 A mark given for axes requires both axes to be labelled with quantities and units, and drawn the correct way round.
- 6.2 Sometimes a separate mark will be given for units or for each axis if the units are complex. This will be indicated on the mark scheme.
- 6.3 A mark given for choosing a scale requires that the chosen scale allows all points to be plotted, spreads plotted points over more than half of each axis and is not an awkward scale e.g. multiples of 3, 7 etc.
- 6.4 Points should be plotted to within 1 mm.
 - Check the two points furthest from the best line. If both OK award mark.
 - If either is 2 mm out do not award mark.
 - If both are 1 mm out do not award mark.
 - If either is 1 mm out then check another two and award mark if both of these OK, otherwise no mark.
- 6.5 For a line mark there must be a thin continuous line which is the best-fit line for the candidate's results.

Question Number	Answer	Mark
1 (a)	Diode or LED (1)	1
(b) (i)	Use of $R = V / I$ current between 75 and 90 ignoring powers of 10 (1) answer 6.7 – 8.0 Ω (1) Example of answer $R = 0.60 \text{ V} \div (85 \times 10^{-3}) \text{ A}$ $R = 7.06 \Omega$	2
(b) (ii)	Infinite OR <u>very</u> high OR ∞	1
(c)	ANY ONE Rectification / AC to DC / DC supply [not DC appliances] Preventing earth leakage Stabilising power output To protect components A named use of LED if linked to LED as component in (a) (eg calculator display / torch) A voltage controlled switch (Allow current in only one direction) [Stopping current going the wrong way 1/1 it stops current 0/1 produces light 0/1]	1
Total for question		5

Question Number	Answer	Mark
2 (a)	<u>Resistivity definition</u> Resistivity = resistance × (1) × <u>cross sectional</u> area / length (1) $\rho = RA/l$ with symbols defined scores 2/2 equation as above without symbols defined scores 1/2 equation given as $R = \rho l/A$ with symbols defined scores 1/2 (1st mark is for linking resistivity to resistance with some other terms) [An answer = resistance of length of 1 m, cross sectional area of 1 m ² scores first mark only]	2
(b) (i)	<u>Resistance calculation</u> Converts kW to W (1) Use of $P = V^2/R$ OR $P = VI$ and $V = IR$ (1) Resistance = 53 Ω (1) Example of answer $R = (230 \text{ V})^2 \div 1000 \text{ W}$ $R = 53 \Omega$	3
(b) (ii)	<u>Length calculation</u> Recall $R = \rho l/A$ (1) Correct substitution of values (1) Length = 6.3 m (accept 6.2 m) (1) ecf value of R Example of answer $l = (52.9 \Omega \times 1.3 \times 10^{-7} \text{ m}^2) \div (1.1 \times 10^{-6} \Omega \text{ m})$ $l = 6.3 \text{ m}$	3
(b) (iii)	Proportion method Identifies a smaller diameter is needed (1) Diameter = 0.29 mm (1) OR Calculation method Use of formula with $l =$ half their value in (b)(ii) (1) Diameter = 0.29 mm (1) (Ecf a wrong formula from part ii for full credit) Example of answer $d_{\text{new}} = 0.41 \text{ mm} \div \sqrt{2}$ $d_{\text{new}} = 0.29 \text{ mm}$	2
Total for question		10

Question Number	Answer	Mark
4 (a)	<p><u>Circuit diagram</u></p> <p>Potentiometer correctly connected i.e potential divider circuit (1)</p> <p>Ammeter in series and voltmeter in parallel with bulb (1)</p> <p>(light bulb in series with resistance can score second mark only)</p>	2
(b) (i)	<p><u>Graph</u></p> <p>+I,+V quadrant; curve through origin with decreasing gradient (1)</p> <p>[do not give this mark if curve becomes flat and then starts going down i.e. it has a hook]</p> <p>-I,-V quadrant reasonably accurate rotation of +I,+V quadrant (1)</p> <p>[labelling only required to identify the axes, e.g. accept A for current]</p> <p>[description above assumes I on y axis, give full credit if I on x-axis providing curve correct.]</p> <p>[If axes are not labelled, second mark can be scored. Straight line graph can score second mark but need to apply ecf below]</p>	2
(b) (ii)	<p><u>Shape of graph</u></p> <p>As current/voltage increases, temperature of the lamp increases / lamp heats up (1)</p> <p>Leading to increase in resistance of lamp (1)</p> <p>Rate of increase in current decreases OR equal increases in V lead to smaller increases in I (1)</p> <p>Qowc (1)</p> <p>[ignore incorrect statements e.g. gradient of graph is resistance, providing they don't contradict a statement you are giving credit for.</p> <p>If graph in (i) curves wrong way, ignore when marking description, i.e. full marks can be scored for description]</p> <p>Ecf if a straight line graph is drawn max 3</p> <p>R constant (1)</p> <p>$V \propto I$ (1)</p> <p>Qowc (1)</p>	4
Total for question		8

PHY2 June 08 Examples of Diagrams / graphs.

Q4 Answer requires a potentiometer circuit.

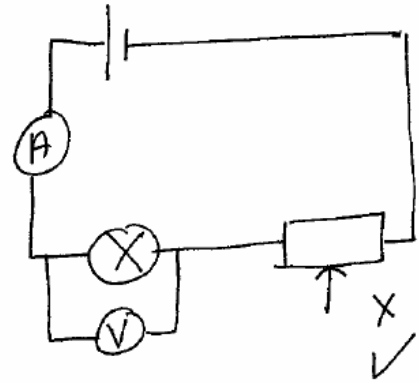
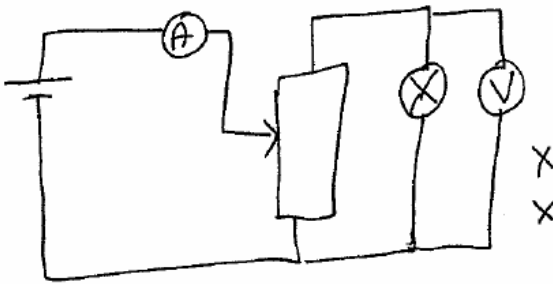
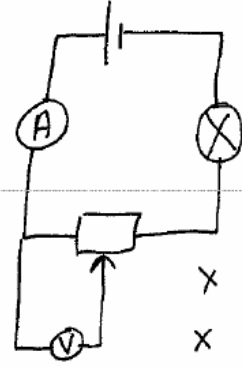
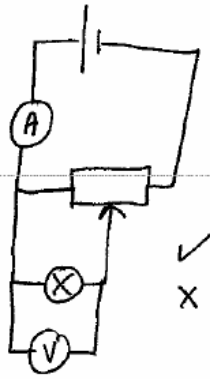
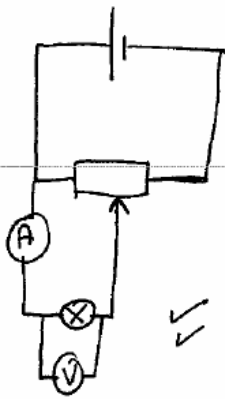

Q4 graph.

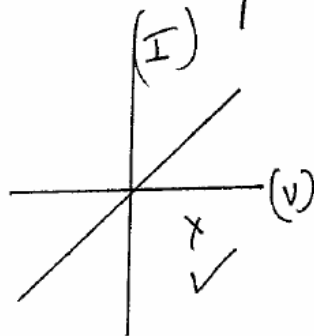
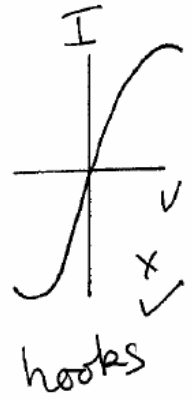
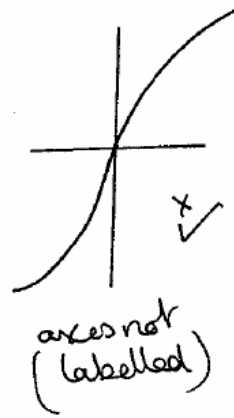
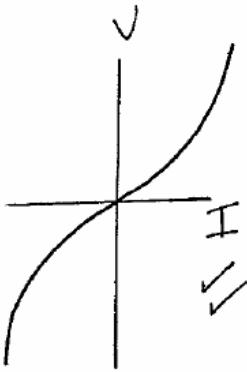
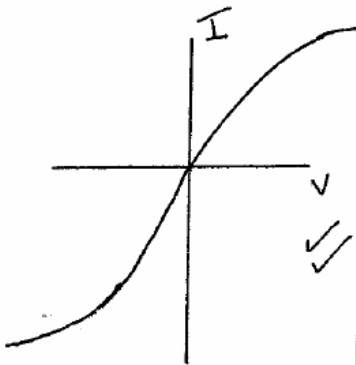

Question Number	Answer	Mark
5(a)	<u>Thermal contact</u> Allows <u>energy</u> to flow from one body/object to another (1) [Give credit for the idea of movement of energy]	1
(b)	<u>Thermometer</u> Difficulty (1) } x 2 Explanation (1) } (Difficulty and explanation might occur in one section or wrong way round) Examples of answers that score 1 or 2 marks. Size of the sample (1) poor thermal contact OR not all of the thermometer in contact with sample (1) Glass/gas is poor conductor (1) slow to respond to temperature changes (1) Slow to respond (1) apparatus is large/bulky or has a large mass (1) Can't measure temperature of a solid (1) poor thermal contact (1) Limited range of temperatures (1) can explode if it gets too hot, or pressures too high. Might make reference to gas liquifying or glass melting (1). Not everything is at the same temperature (1) length of tubing or size of apparatus or size of sample (1). Glass bulb might expand on heating (1) so volume might not be constant (1) Thermometer takes heat from sample (1) so result not accurate (1) Coarse scale on pressure gauge (1) inaccurate results (1) Examples of answers that score 1 mark maximum Not very portable (1) Calculations have to be done (1) Takes a long time to set up (1) Fragility of glass (1) [Bald statement 'inaccurate results' scores zero] [any reference to insulation or energy loss or leaky tubing gains no credit]	4
Total for question		5

Question Number	Answer	Mark
6(a)	<p><u>Absolute zero of temperature</u> (Temperature at which) pressure / volume (of a gas) is zero. (1) OR (Temperature at which) the <u>kinetic energy</u> of the molecules is zero [accept particles or atoms]</p>	1
(b) (i)	<p><u>Number of moles show that calculation</u></p> <p>Recall $pV = nRT$ (1) Addition of air pressure (1) Conversion to kelvin (1) Number of moles = 0.52 (mol) (1) [you must work through the calculation correct $pV = 1218$ correct $RT = 2349$ if pressures are not added $n = 0.27$ so 2/4]</p> <p>Reverse calculations using $n = 0.5$ to arrive at one of the other values can score maximum 3</p> <p>Example of answer</p> $n = \frac{((1.0 + 1.1) \times 10^5 \text{ Pa} \times 5.8 \times 10^{-3} \text{ m}^3)}{8.31 \text{ J K}^{-1} \text{ mol}^{-1} \times (273 + 10) \text{ K}}$ <p>$n = 0.52 \text{ mol}$</p>	4
(b) (ii)	<p><u>Mass of air</u> Mass = $1.5 \times 10^{-2} \text{ kg}$ (1) [use of $n = 0.5 \text{ mol}$ gives mass = 0.0145 kg and scores mark] [ecf incorrect values of n]</p> <p>Example of answer mass = $0.52 \text{ mol} \times 0.029 \text{ kg mol}^{-1} = 0.015 \text{ kg}$</p>	1
(b) (iii)	<p><u>Temperature calculation</u></p> <p>Use of $P_1/T_1 = P_2 / T_2$ (1) Correct $P_2 1.6 \times 10^5 \text{ Pa}$ (1) Lowest temperature = 216 K (-57 °C) (1)</p> <p>OR</p> <p>Use of $pV = nRT$ (must see correct value of R) (1) Correct $P_2 1.6 \times 10^5 \text{ Pa}$ (1) Lowest temp 215K - 223K (-58 to -50 °C) (1)</p> <p>[if candidates <u>do not add AP in (b)(i) or have incorrect conversion to K</u> do not penalise them again. Failing to add AP leads to 80.9 or 81 K]</p> <p>Example of answer</p> $T_2 = \frac{((1.0 + 0.6) \times 10^5 \text{ Pa} \times 283 \text{ K})}{2.1 \times 10^5 \text{ Pa}}$ <p>$T_2 = 216 \text{ K}$</p>	3
Total for question		9

Question Number	Answer	Mark
7(a)	<u>Smoke particle motion</u> (Smoke particles) move due to collisions with air <u>molecules</u> [accept pushed by] (1) Resultant force is produced by the collision imbalance/multiple collisions OR Idea of varying or different resultant force OR change of momentum (1)	2
(b)	<u>Air molecules motion</u> Motion of (air molecules) is random OR collisions are random (1) [Molecules have different directions and speeds scores this mark] EITHER: They are moving fast/faster than smoke particles OR The smoke particles are hit by different numbers of (air molecules) OR Large number of (air molecules) (1)	2
(c)	<u>Motion of one particle</u> A single path that has Different length straight sections (arrows not necessary) (min 5) (1) In different directions (1) [Repetitive pattern can score 1/2]	2
Total for question		6

Question Number	Answer	Mark
8(a)	<u>Mean square speed</u> Attempt to find either squares or a mean of all 5 values (1) $\langle c^2 \rangle = 3.1 \times 10^5$ (311640) as answer (1) $\text{m}^2 \text{s}^{-2}$ (1) (The unit mark is independent)	3
(b)	<u>Real gas molecules</u> No forces (negligible force) act or no bonds (1) Between molecules / particles / atoms (1) (consequent mark) (No external force is acceptable for the first mark.) (Ignore reference to gravity / gravitational forces) (collisions are elastic so there is no PE scores zero)	2
Total for question		5
Total for paper		60