

1. No mark scheme available

2. The list gives some quantities and units. *Underline* those which are base quantities of the International (SI) System of units.

coulomb    force    length    mole    newton    temperature interval

(2 marks)

Define the volt.

**Volt = Joule/Coulomb or Watt/Ampere**

(2 marks)

Use your definition to express the volt in terms of base units.

**Volt = J/C**

**= kg m<sup>2</sup> s<sup>-2</sup>/A s**

**= kg m<sup>2</sup> s<sup>-3</sup> A<sup>-1</sup>**

(3 marks)

Explain the difference between scalar and vector quantities

**Vector has magnitude and direction**

**Scalar has magnitude only**

(2 marks)

Is potential difference a scalar or vector quantity?

**Scalar**

(1 mark)

[Total 10 marks]

3. The diagram shows a lever with two arms of equal length and with a 30 kg mass at one end. The force  $F$  is just strong enough to raise the 30 kg mass off the ground.

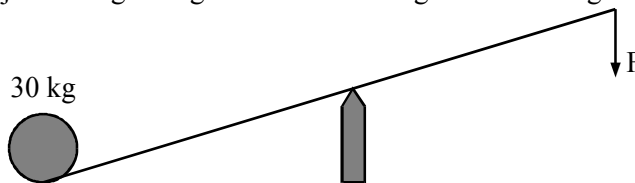

Calculate the magnitude of the force  $F$

**$F = 30 \times 9.81$  or  $30 \times 10$**

**$F = 294 \text{ N}$  or  $300 \text{ N}$**

(2 marks)

Instead of applying the force  $F$  to the far end of the lever, a 34 kg mass is placed there.

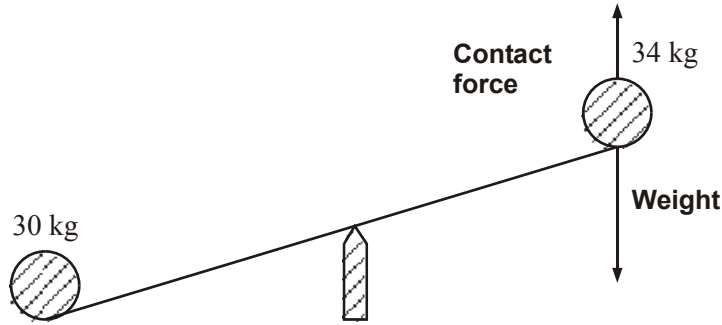

Draw on the diagram above, the forces acting on the 34 kg mass. Explain why it accelerates downwards.

**There is a resultant force downwards because the weight exceeds the contact force.**

**(4 marks)**  
**[Total 6 marks]**

4. The graph shows how the height above the ground of the top of a soft bouncing ball varies with time.

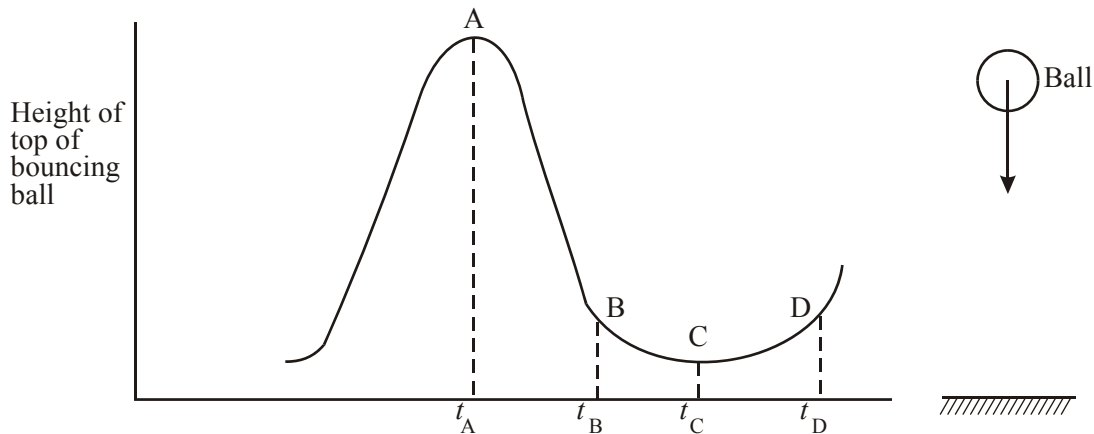

Describe briefly the principal energy changes which occur between the times

$t_A$  and  $t_B$

**The ball loses gravitational potential energy and gains kinetic energy**

**(2 marks)**

$t_B$  and  $t_C$

**The kinetic energy is transformed into elastic potential energy when the ball deforms on the ground.**

**(3 marks)**

$t_C$  and  $t_D$

**The elastic potential energy is converted back into kinetic energy**

**(1 mark)**

**[Total 6 marks]**

5. Draw a labelled diagram of the apparatus you would use to measure the acceleration of a body in free fall.

**Diagram showing**

**relevant distance**  
**timing devices**  
**disposition of equipment**

**(3 marks)**

List the measurements you would make and show how you would use them to calculate the acceleration.

**measure and record which distance**  
**measure and record which time**  
**repeat for other distances**  
**graph of distance against time<sup>2</sup>**  
**acceleration of free fall**  
**equals twice the gradient**

**(5 marks)**

**[Total 8 marks]**

6.  $^{12}_6\text{C}$  and  $^{14}_6\text{C}$  are two isotopes of carbon.

State the number of electrons in a neutral atom of  $^{14}_6\text{C}$

**6**

State the number of neutrons in a neutral atom of  $^{14}_6\text{C}$

**8**

**(2 marks)**

$^{14}_6\text{C}$  decays by beta minus emission. Complete the nuclear equation below.

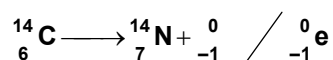

**(2 marks)**

Describe briefly how you would test whether  $^{14}_6\text{C}$  decays *only* beta emission

**(Using G.M. Tube) Take background reading (1)**

**Valid test to show  $\alpha$  present/absent eg insert paper + effect on c.p.m. (1)**

**Valid test to show  $\beta$  present/absent (1)**

**Other methods: apply same 3 points**

**(3 marks)**

**[Total 7 marks]**

7. State Newton's second law of motion.

**Statement for magnitude (1)**

**Statement for direction (1)**

**(2 marks)**

A student says, incorrectly, "Momentum is conserved completely in elastic collision, but not in inelastic collisions." Rewrite this sentence to make a correct statement about momentum conservation.

**Momentum is conserved in any collision**

(1 mark)

In what circumstance is kinetic energy conserved in a collision?

**Kinetic energy is conserved in elastic collisions**

(1 mark)

**[Total 4 marks]**

8. At the battle of Agincourt in 1415, the English archers overcame a much stronger French army by shooting arrows from longbows which required a maximum force of about 800N to draw the string back a distance of half a metre. The graph shows the force-extension graph for a helical spring stretched elastically throughout this distance by this force.

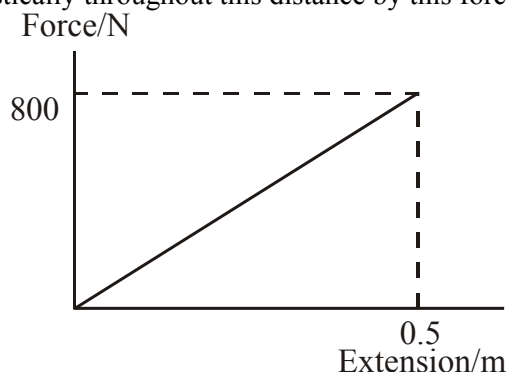

Calculate the energy stored in the spring for an extension of half a metre.

**Energy stored = correct area or  $\frac{1}{2} \times \text{force} \times \text{extension}$  (1)**

**$= \frac{1}{2} (800 \text{ N}) (0.50\text{m})$**

**Energy = 200 J (1)**

**(2 marks)**

The arrows used at Agincourt were able to penetrate light armour and had a mass of about 60 g. Use your calculated value of energy to find an approximate value for the speed at which the arrow would leave the bow.

**$\frac{1}{2} mv^2 = 200$  (1)**

**$v = \frac{\sqrt{(200 \text{ J}) \times 2}}{0.060 \text{ kg}}$  (1)**

**$= 82 \text{ m s}^{-1}$  (1)**

**(3 marks)**

In practice, the energy stored in the drawn bow is more than that stored in the helical spring stretched the same amount by the same force. Sketch, on the axes bow, a possible force-extension graph for this bow.

**Line drawn on graph at beginning of question with the same start and finish points (1)**

**and enclosing larger area below (1)**

**(2 marks)**

The arrows were fired upwards at an angle of  $45^\circ$  to the horizontal. Describe and explain what happens during the flight to the

- (i) horizontal velocity component  
**(Modest) decrease (1)**  
**due to air resistance (1)**  
**OR no change because no forces are operating (1 only)**

(2 marks)

- (ii) vertical velocity component  
**Upwards velocity decreases to zero (1)**  
**and then increases downwards (1)**  
**because of gravity (1)**  
**(Accept alternative answer in terms of energy changes)**

(3 marks)

[Total 12 marks]

9. Describe, with the aid of a diagram, how you would measure the acceleration of free fall by a method involving the use of a freely-falling body.

**Diagram showing any apparatus which could be used for this purpose (1)**

**Clear statement of two separate measurements which could lead to a value for 'g' (1) each  $\times 2$  (2)**

**How 'g' is to be found from these measurements (2)**  
**(-1) for each error or omission**

**Repetition or a graph from a series of measurements (1)**

(6 marks)

Identify and explain one precaution you would take to minimise the errors in your experiment.

**Increase fall time (1)**  
**to minimise timing errors (1)**  
**or several readings at each distance (1) to minimise random errors (1)**  
**or suitable alternatives (2)**

(2 marks)

[Total 8 marks]

10. (a) (i)  **$Y = \underline{637 \text{ N to } 650 \text{ N}}$  (1)**  
 **$X = \underline{520 \text{ N}}$  (1)**

- (ii) **Component  $Y$  and the weight (638 N) form/ there is an anticlockwise couple/moment/torque (1)**

**Equilibrium is achieved if  (1)**

(4 marks)

- (b) **Attempt to use  $ma = F$  (1)**  
 **$(65 \text{ kg})a = 520 \text{ N}$  (1)**

**$\Rightarrow a = \underline{8.0 \text{ m s}^{-2}}$  (1)**

**Force  $X$  reduces as she slows/  $X$  depends on speed (1)**

(4 marks)

- (c) (i) Moving in curved path means added sideways component of force/accelerating centripetally (1)  
and more/extra force/tow rope pull is required for this (1) (2 marks)
- (ii) The only vertical force on her is her weight/gravity (1)  
(not "no vertical reaction")  
(so) she accelerates vertically at  $9.8 \text{ m s}^{-2}/g$  /in free fall (1) (2 marks)

(d)

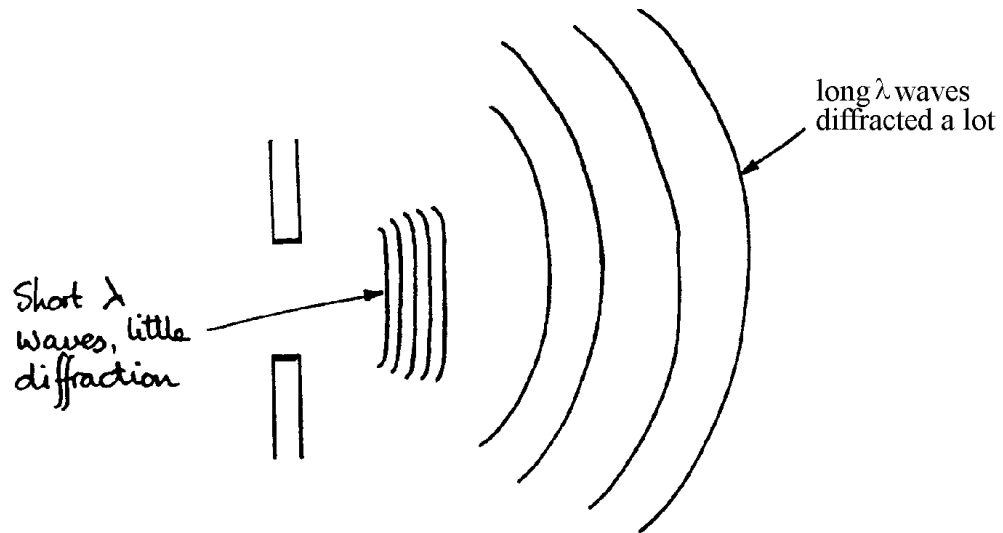

- Word "diffraction" in text or on diagram (1)  
Long  $\lambda$  further on than short  $\lambda$  (1)  
Gap (2 m) and waves reasonable scale (1)  
Short  $\lambda$  shown with little diffraction (1)  
Long  $\lambda$  shown with lots of diffraction (1)

(4 marks)  
[Total 16 marks]

11. (a) (i)  $P = \frac{mgh}{t}$  (Allow  $P = Fv$ )  $54.9 \text{ N} \times 2.31 \times 10^{-6} \text{ m s}^{-1}$  (1)  
 $= \frac{5.6 \text{ kg} \times 9.8 \text{ N kg}^{-1} \times 1.4 \text{ m}}{7 \times 24 \times 3600 \text{ s}}$  (1)  
 $= 1.3 \times 10^{-4} \text{ W}$  (1)

If only  $mgh$  calculated (77 J), max (1)

(3 marks)

- (i) Use of  $mc\Delta\theta$   
 A valid expression for  $\theta$   
 or answer  $0.038 \text{ }^\circ\text{C/K}$  (0.039 if 10 used) (1)  
 Assumption: all g.p.e. becomes internal energy/  
 all heat in the cylinder / no heat loss / no air friction (1)

(3 marks)

- (b) (i) **Mention of Earth's magnetic field** (1)  
**[Look for back credit from part (c)]**  
**Pendulum cuts this field/flux** (1)  
**So e.m.f./p.d. is induced (not current)** (1)

(3 marks)

(ii)

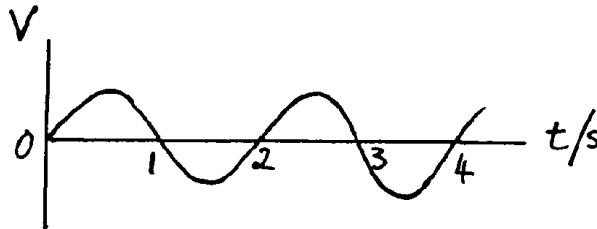

- Any repetitive graph** (1)  
**Sinusoidal in shape** (1)  
**Time scale correct (i.e. period 2 s)** (1)

(3 marks)

- (c) **Statement that energy conservation is violated/**  
**perpetual motion machines are impossible/**  
**drawing power would damp oscillation** (2)  
**(Allow not practicable to connect to bottom of pendulum for 1 mark only)**  
**Discussion: induced p.d./e.m.f. could produce a current** (1)  
**which would dissipate/use energy** (1)  
**Switches could attract steel at correct part of swing** (1)

(Max 4 marks)  
 [Total 16 marks]

12. With the aid of an example, explain the statement "The magnitude of a physical quantity is written as the product of a number and a unit".

- Both number and unit identified in an example** (1)  
**followed by the idea of multiplication** (1)

(2 marks)

Explain why an equation must be homogeneous with respect to the units if it is to be correct.

- If the units on one side differ from those on the other, then the two sides of the equation relate to different kinds of physical quantity. They cannot be equal [or similar positive statements]** (1)

(1 mark)

Write down an equation which is homogeneous, but still incorrect.

- Any incorrect but homogeneous algebraic or word equation :**  
 **$2mgh = \frac{1}{2}mv^2$ ,  $2 \text{ kg} = 3 \text{ kg}$ , pressure = stress/strain** (2 or 0)

(2 marks)  
 [Total 5 marks]

13. An athlete of mass 55 kg runs up a flight of stairs of vertical height 3.6 m in 1.8 s. Calculate the power that this athlete develops in raising his mass.

$$\text{Power} = \frac{(55 \text{ kg}) \times (9.81 \text{ N/kg}) \times (3.6 \text{ m})}{(1.8 \text{ s})}$$

**Numerator correct (1)**

**Denominator correct (1)**

$$\text{Power} = 1080 \text{ W} \quad (1)$$

**(3 marks)**

One way of comparing athletes of different sizes is to compare their power-to-weight ratios. Find a unit for the power-to-weight ratio in terms of SI base units.

**Units correctly attached to a correct equation (1)**

$$\text{e.g. } \frac{\text{power}}{\text{weight}} = \frac{\text{N m s}^{-1}}{\text{N}} \quad (1)$$

$$= \text{m s}^{-1} \quad (1)$$

**(0) if m s<sup>-1</sup> is derived wrongly**

**(2 marks)**

Calculate the athlete's power-to-weight ratio.

$$\text{Power to weight ratio} = \frac{(1080 \text{ W})}{(55 \text{ kg}) \times (9.81 \text{ m s}^{-2})} \quad (1)$$

$$\text{Power-to-weight ratio} = 2 \text{ [m s}^{-1}] \quad (1)$$

**(Unit error not penalised in final part)**

**(2 marks)**

**[Total 7 marks]**

14. The diagram shows a velocity-time graph for a ball bouncing vertically on a hard surface.

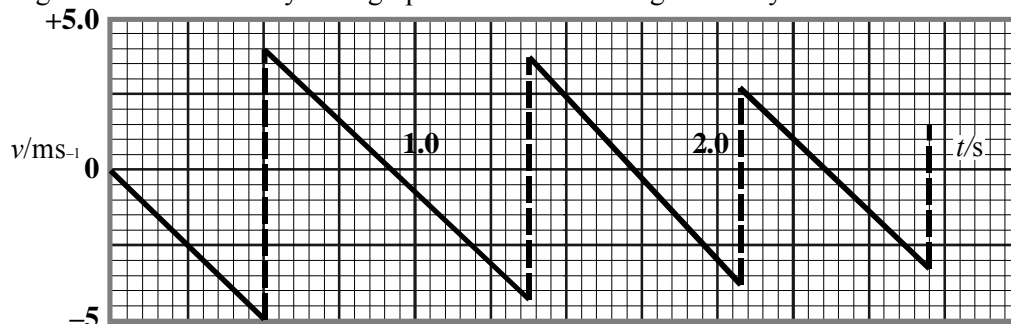

At what instant does the graph show the ball to be in contact with the ground for the third time?

$$2.05 \text{ s} \leq t \leq 2.10 \text{ s} \quad (2)$$

**OR**

$$2.00 \leq t \leq 2.20 \text{ s} \quad (1)$$

**(2 marks)**

The downwards-sloping lines on the graph are straight. Why are they straight?

**Acceleration of the ball or force on the ball or gravitational field strength is constant or uniform (2 or 0)**

**(2 marks)**

Calculate the height from which the ball is dropped.



Relevant equation or correct area (1)

Substitution correct (1)

Answer ( $1.2 \text{ m} \leq \text{height} \leq 1.3 \text{ m}$ ) (1)

(3 marks)

Sketch a displacement-time curve on the axes below for the first second of the motion.

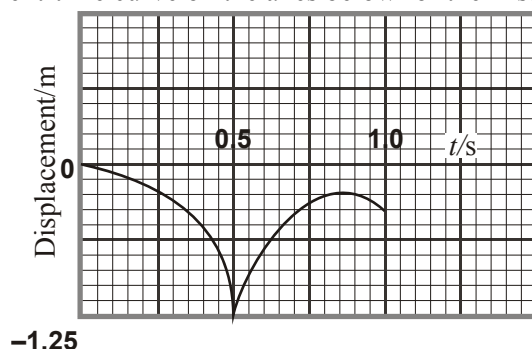

Displacement scale agreeing with above (1)

First half of curve correct (1)

Second half correct with reduced height (1)

(3 marks)

What is the displacement of the ball when it finally comes to rest?

**-1.25 m (correct magnitude *and* direction)**

**(Look at candidate's displacement origin)**

(1 mark)

[Total 11 marks]

15. Describe an experiment you would perform to provide a *single* illustration of the principle of conservation of linear momentum.

(i) Sketch and label a diagram of the apparatus you would use.

**Air track or apparatus with identified friction compensation (1)**

**Possibility of collision (1) (allow 'explosion')**

**[If there is no possibility of a collision, then maximum of (1) for question]**

(2 marks)

(ii) List the physical quantities you would measure and state how you would measure them.

**Method for measuring masses (1)**

**Measure speed (1)**

**Identify which speeds are to be measured (1)**

**How speed is measured (1)**

(4 marks)

(iii) How would you use this information to provide a single illustration of the law

**Evaluate momentum before collision and momentum after collision (1)**

**Explain how the law is illustrated (1)**

(2 marks)

[Total 8 marks]

16. In 1909 Geiger and Marsden carried out an important experiment to investigate alpha particle scattering. Alpha particles were directed towards a thin gold sheet and detectors were used to observe the distribution of scattered alpha particles.

State what was observed in this experiment.

**Some  $\alpha$  particles pass } straight through (or equivalent) (1)**  
**Some flashes are seen }**

**Some are deflected slightly (1)**

**Some rebound (or equivalent) (1)**

**(3 marks)**

Explain why these observations led to the conclusion that an atom was composed mainly of space, with very small positive nucleus.

**(Repulsion) links positive  $\alpha$  particles and positive nucleus (1)**

**Link large proportion straight through and (1)**

**small proportion strongly deviated with mainly space and small nucleus (1)**

**(3 marks)**

State an approximate value for

(i) the diameter of a gold atom  
 **$10^{-9}/10^{-10}/10^{-11}$  m (1)**

(ii) the diameter of a gold nucleus  
 **$10^{-13}/10^{-14}/10^{-15}$  m (1)**

**Unit penalty once**

**(2 marks)**

**[Total 8 marks]**

17. Name *two* sources of natural background radiation.

**1) Two sources of different origin,**

**2) e.g. cosmic radiation; rocks (1) (1)**

**(2 marks)**

Caesium-137 is a by-product of nuclear fission within a nuclear reactor. Complete the two boxes in the nuclear equation below which describes the production of  $^{137}_{55}\text{Cs}$ .



**37 (1), 4 (1)**

**(2 marks)**

The half-life of caesium-137 is 30 years. When the fuel rods are removed from a nuclear reactor core, the total activity of the caesium-137 is  $5.8 \times 10^{15}$  Bq. After how many years will this activity have fallen to  $1.6 \times 10^6$  Bq.

$$1.6 \times 10^6 = 5.8 \times 10^{15} e^{-\lambda t} \text{ (OR } N_t = N_o \dots) \quad (1)$$

Correct value of  $\lambda$  (1)

Correct use of ln's (1)

$$\text{OR Use of } \frac{1.6 \times 10^6}{5.8 \times 10^{15}} = (1/2)^n \text{ for full credit}$$

$$\text{Number of years} = 950 - 960 \quad (1)$$

(4 marks)

Comment on the problems of storage of the fuel rods over this time period.

Two problems which are relevant to (1)

the very long storage time involved (1)

eg deterioration of container; finding a site which will remain safe;  
long term monitoring.

(2 marks)

[Total 10 marks]

18. An artery has a cylindrical cross-section of diameter 8 mm. Blood flows through the artery at an average speed of  $0.3 \text{ m s}^{-1}$ .

Calculate the average mass of blood flowing per second through the artery.

Density of blood at body temperature,  $37^\circ\text{C} = 1060 \text{ kg m}^{-3}$ .

Use of  $\pi r^2 h$  (1)

Substitute ( $4 \times 10^{-3}$ ) and (0.3) (1) (1)

(Volume  $\rightarrow$  multiply by density)  $\times 1060$  (1)

Mass of blood =  $1.6 \times 10^{-2} \text{ kg/kg s}^{-1}$  (1)  
or  $16 \text{ g/g s}^{-1}$

Error carried forward: wrong value for radius

Unit penalty

(5 marks)

How would you verify experimentally the value of the density of blood quoted above, given a sample of volume approximately  $5 \text{ cm}^3$ ?

Measure volume in small measuring cylinder/syringe/pipette (1)

Volume taken at  $37^\circ\text{C}$ /volume not significantly different at  $37^\circ\text{C}$ /  
measure mass and volume in same container/  
use balance  $\rightarrow 0.01 \text{ g} \rightarrow$  highly sensitive (1)

Mass blood = total mass - container mass (1)

(3 marks)

[Total 8 marks]

19. State Coulomb's law for the electric force between two charged particles in free space.

**Force is proportional to the product of the charges and inversely proportional to the distance between them squared (1) (1)**

**(OR  $F = \frac{kQ_1Q_2}{r^2}$  with symbols defined (1) (1))**

**(2 marks)**

What are the base units of  $\epsilon_0$  (the permittivity of free space)?

$\epsilon_0 \rightarrow \text{A}^2 \text{ s}^4 \text{ kg}^{-1} \text{ m}^{-3}$  (1) (1)

**[Compensation marks, Maximum 1/2:  $C^2 = A^2 s^2$**

**$\mu_0 = \text{kg m s}^{-2} \text{ A}^{-2}$**

**Farad  $\text{m}^{-1} = \text{A s m}^{-1} \text{ V}$**

**Force  $\times r^2 = \text{kg m}^3 \text{ s}^{-2}$ ]**

**(2 marks)**

**[Total 4 marks]**

20. (a) Describe briefly how you would determine a value for the *specific heat capacity*  $c$  of water using normal laboratory apparatus.

**Electrical method**

**Method of mixtures**

**Electrical heater**

**Know temperature of hot body (1)**

**Water in container with thermometer**

**Water in container with thermometer (1)**

**$I V t$  or  $Pt$  or joulemeter**

**Heat capacity of apparatus (1)**

**$mc\Delta\theta$**

**$mc\Delta\theta$  (1)**

**Precaution: low C container/insulation/lid/stir (1)**

**(Max 4 marks)**

(b) A jogger of mass 75 kg, who runs for 30 minutes, generates 840 kJ of thermal energy.

(i) Explain, in molecular terms, the way in which the removal of some of this energy by evaporation can help to prevent the jogger's body temperature from rising.

**Fast energetic molecules escape/evaporate (1)**

**Remaining ones have less kinetic energy/when bonds broken (1)**

**Reference to latent heat from jogger (1)**

**(3 marks)**

If 40% of the thermal energy is removed by evaporation, calculate the mass of water evaporating during the 30 minute jog. Take the specific latent heat (enthalpy) of vaporisation of water to be 2260 kJ  $\text{kg}^{-1}$  and the density of water to be 1000  $\text{kg m}^{-3}$

**40% of 840 kJ =  $336 \times 10^3 \text{ J}$  (1)**

**$H = ml \Rightarrow m = H/l$  (1)**

**$\Rightarrow m = 0.15 \text{ kg}/150 \text{ g}$  (1)**

**(3 marks)**

- (c) During a single stride the *horizontal push*  $F$  of the ground on the jogger's foot varies with time  $t$  approximately as shown in the graph.  $F$  is taken to be positive when it is in the direction of the jogger's motion.

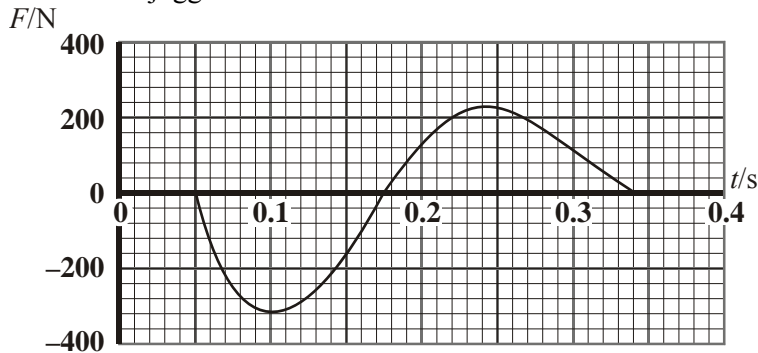

- (i) What physical quantity is represented by the area between the graph line and the time axis?

**Impulse/change of momentum (1)**

Estimate the size of this quantity for the part of the graph for which  $F$  is positive.  
Explain how you made your estimate.

**Area: counting squares or  $F_{av} \times t$  or use of triangles (1)**

**$\geq 15 \leq 25$  (1)**

**$N \text{ s/kg m s}^{-1}$  (1)**

**(4 marks)**

- (ii) The area above the time axis is the same as the area below it. Explain what this tells you about the motion of the jogger.

**Net impulse/change of momentum zero (1)**

**so jogger has constant speed/velocity (1)**

**(2 marks)**

**[Total 16 marks]**

21. An  $\alpha$ -source with an activity of 150 kBq is placed in a metal can as shown. A 100 V d.c. source and a  $10^9 \Omega$  resistor are connected in series with the can and the source. This arrangement is sometimes called an ionisation chamber.

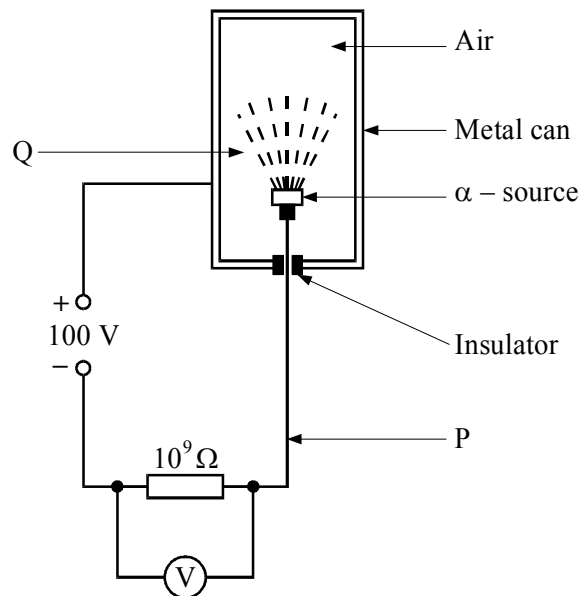

- (a) What is meant in this case by *an activity of 150 kBq*?  
 **$150 \times 10^3$  particles/decays/disintegrations (1)**  
**per second (1)**

(2 marks)

- (b) Describe how the nature of the electric current in the wire at P differs from that in the air at Q.

**At P: negatively charged/delocalised (1)**  
**electrons (1)**

**At Q: ions (1)**

(3 marks)

- (c) A potential difference of 3.4 V is registered on the voltmeter.

- (i) Calculate the current in the wire at P. State any assumption you make.

$$I = \frac{V}{R} \quad (1)$$

$$\Rightarrow I = 3.4 \times 10^{-9} \text{ A} \quad (1)$$

**Assume resistance of voltmeter greater than  $10^9 \Omega$ /very big or no/very little current voltmeter (1)**

- (ii) Calculate the corresponding number of ionisations occurring in the metal can every second. State any assumption you make.

**Assume ions singly charged/there is no recombination (1)**

**Use of  $1.6 \times 10^{-19} \text{ C}$  (1)**

$$\Rightarrow N = \frac{3.4 \times 10^{-9} \text{ C}}{1.6 \times 10^{-19} \text{ C}} \quad (1)$$

(Max 5 marks)

- (d) With the  $\alpha$ -source removed from the metal can, the voltmeter still registers a potential difference of 0.2 V. Suggest two reasons why the current is not zero.

**Insulator not perfect (1)**

**Voltmeter has zero error (1)**

**Background radiation (1)**

(2 marks)

- (e) The half-life of the  $\alpha$ -source is known to be 1600 years. Calculate the decay constant and hence deduce the number of radioactive atoms in the source.

$$\lambda t_{1/2} = \ln 2 \quad (1)$$

$$\Rightarrow \lambda = 1.37 \times 10^{-11} \text{ s}^{-1} \text{ or } 4.33 \times 10^{-4} \text{ y}^{-1} \quad (1)$$

$$\Rightarrow N = 1.1 \times 10^{16} \quad (1)$$

(4 marks)

[Total 16 marks]

22. The free-body force diagram shows the two principal forces which act on a parachutist at the instant of first contact with the ground.

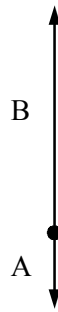

What does the force A represent?

**Weight of parachutist (1)**

(1 mark)

What does the force B represent?

**Reaction from ground on parachutist (1)**

(1 mark)

Why are these forces not equal?

**Because the parachutist has a negative acceleration (1)  
which requires a net upwards force (1)**

(2 marks)  
[Total 4 marks]

23. The diagram illustrates an elastic collision between two spheres, A and B, of equal mass.

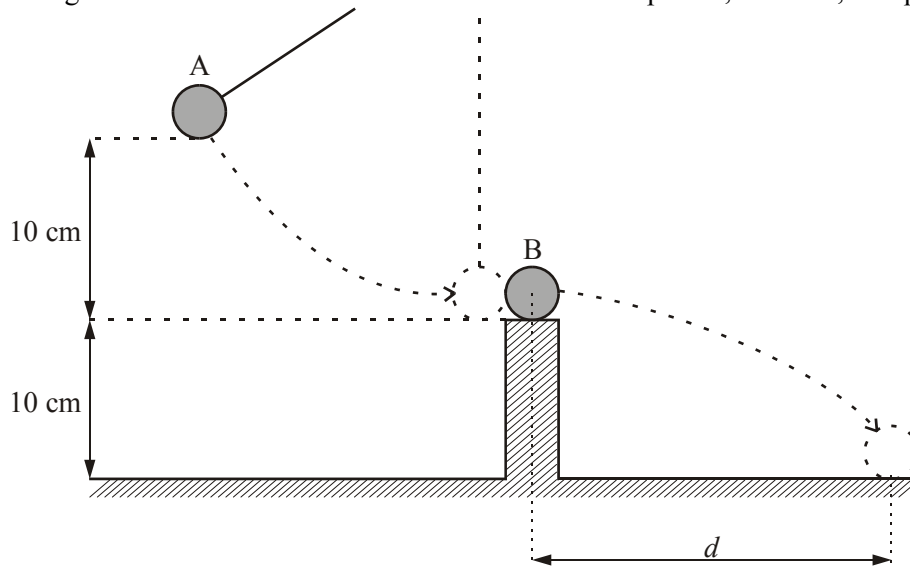

Sphere A is tied to the end of a long vertical thread and pulled to one side until it has risen a distance of 10 cm. It is then released and comes to rest when it strikes the sphere B which is resting on a smooth flat support.

Sphere B travels a horizontal distance  $d$  before it hits the ground after falling 10 cm.

Calculate the speed of A as it strikes B.

**Gain of kinetic energy = loss in potential energy (1)**

$$v = \sqrt{2gh} \quad (1)$$

$$\sqrt{2 \times (9.8 \text{ m s}^{-2}) \times (0.10 \text{ m})} \quad (1)$$

**Speed = 1.4 m s<sup>-1</sup> (1)**

(4 marks)

How long does B take to fall 10cm?

$$t = \sqrt{2s/g} \quad (1)$$

$$= \sqrt{2 \times (0.10 \text{ m}) / (9.8 \text{ m s}^{-2})} \quad (1)$$

**Time = 0.14 s (1)**

(3 marks)

What is the speed of B just after the collision?

**1.4 m s<sup>-1</sup> (1)**

(1 mark)

Calculate the distance  $d$

**Distance = speed  $\times$  time = (1.4 ms<sup>-1</sup>) (0.14s) (1)**

**Distance = 0.20 m (1)**

(2 marks)

Explain briefly why B drops a distance of 10 cm much more quickly than A.

**B is in free fall (1)**

**while the downwards acceleration of A is inhibited by the upward tension in the string (1)**

(2 marks)

[Total 12 marks]

24. The graph shows the horizontal speed  $v$  of a long jumper from the start of his run to the time when he reaches the take-off board.

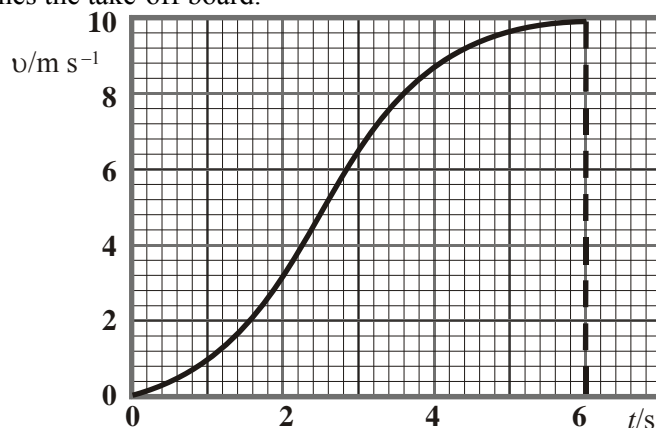



Use the graph to estimate his maximum acceleration.

$$\text{Maximum acceleration} = \text{maximum gradient} \quad (1)$$

$$= (10 \text{ m s}^{-1} / (2.5 \text{ s})) \quad (1)$$

$$\text{Acceleration} = 4 \text{ m s}^{-2} \text{ (allow } \pm 0.5 \text{ m}^{-2}) \quad (1)$$

(3 marks)

Use the graph to estimate the distance of the 'run-up'.

$$\text{Distance} = \text{area between graph and time axis} \quad (1)$$

$$\text{Distance} = 33 \text{ m (allow } \pm 3 \text{ m)} \quad (1)$$

(2 marks)

[Total 5 marks]

25. The diagram shows a mass attached by a piece of string to a glider which is free to glide along an air track.

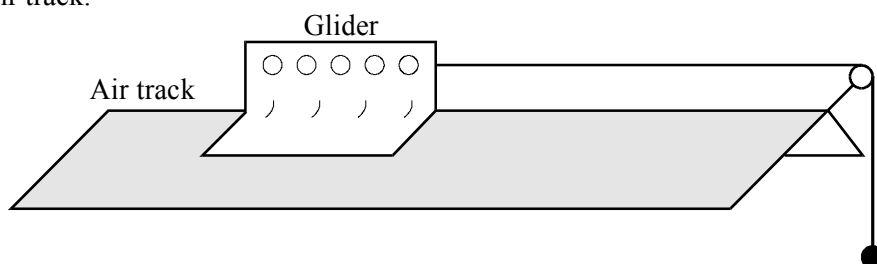

A student finds that the glider takes 1.13 s to move a distance of 90 cm starting from rest.

Calculate the speed of the glider after 1.13 s.

$$\text{Since } u = 0 \quad (1)$$

$$\text{Final speed} = 2 \times \text{average speed} \quad (1)$$

$$= 2 \times (0.90 \text{ m}) / 1.13 \text{ s} \quad (1)$$

$$\text{Speed} = 1.59 \text{ m s}^{-1} \quad (1)$$

(4 marks)

Calculate its average acceleration during this time.

$$\text{Average acceleration} = \text{increase in speed/time} \quad (1)$$

$$= (1.59 \text{ m s}^{-1} / (1.13 \text{ s})) \quad (1)$$

$$\text{Average acceleration} = 1.41 \text{ m s}^{-2} \quad (1)$$

(3 marks)

How would you test whether or not the acceleration of the glider is constant?

$$\text{Attach ticker tape to glider} \quad (1)$$

$$\text{Cut tape up into 10 dot lengths and lay them side by side} \quad (1)$$

$$\text{They should form a straight line graph for constant acceleration} \quad (1)$$

(3 marks)

[Total 10 marks]

26. A mass is oscillating vertically on the end of a spring. Explain what happens to the following quantities as the mass rises from the bottom of its motion to the top.

Kinetic energy

**Increases from zero at bottom to maximum at midpoint (1)  
and falls back to zero at the top (1)**

**[1 only for increases and then decreases]**

Gravitational potential energy

**Increases as the height increases (1)**

Elastic potential energy

**Decreases from maximum position at bottom (1)**

**(ignore reference to possible eventual increase)**

**(4 marks)**

After a long time, the mass stops oscillating. What has happened to the energy?

**Transformed (by friction) into heat (1)**

**in the spring or in the surroundings (1)**

**(2 marks)**

**[Total 6 marks]**

27. Using the usual symbols write down an equation for

- (i) Newton's law of gravitation

$$\mathbf{F} = \mathbf{G} \frac{\mathbf{M}_1\mathbf{M}_2}{\mathbf{R}^2} \quad (1)$$

- (ii) Coulomb's law

$$\mathbf{F} = \mathbf{K} \frac{\mathbf{Q}_1\mathbf{Q}_2}{\mathbf{R}^2} \quad (1)$$

**(2 marks)**

State one difference and one similarity between gravitational and electric fields.

Difference

**Gravitational fields are attractive but electric fields can be attractive or repulsive (1)**

Similarity

**Both have an  $\propto$  range (1)**

**(2 marks)**

A speck of dust has a mass of  $1.0 \times 10^{-18}$  kg and carries a charge equal to that of one electron. Near to the Earth's surface it experiences a uniform downward electric field of strength  $100 \text{ N C}^{-1}$  and a uniform gravitational field of strength  $9.8 \text{ N kg}^{-1}$ .

Draw a free-body force diagram for the speck of dust. Label the forces clearly.

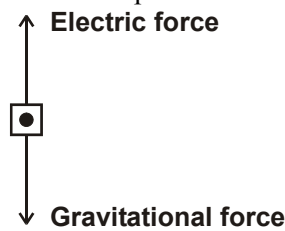

Calculate the magnitude and direction of the resultant force on the speck of dust.

**Electric force** =  $100 \text{ N C}^{-1} \times 1.6 \times 10^{-19} \text{ C}$   
 =  $1.6 \times 10^{-17} \text{ N}$  (1)

**Weight** =  $9.8 \times 10^{-18} \text{ N}$  (1)

**Net force is upward** (1)

**Force =  $6.2 \times 10^{-18} \text{ N}$**  (1)

(6 marks)  
 [Total 10 marks]

28. For each of the four concepts listed in the left hand column, place a tick by the correct example of that concept in the appropriate box.

A base quantity	mole	<input type="checkbox"/>	length	<input checked="" type="checkbox"/>	kilogram	<input type="checkbox"/>
A base unit	coulomb	<input type="checkbox"/>	ampere	<input checked="" type="checkbox"/>	volt	<input type="checkbox"/>
A scalar quantity	torque	<input type="checkbox"/>	velocity	<input type="checkbox"/>	kinetic energy	<input checked="" type="checkbox"/>
A vector quantity	mass	<input type="checkbox"/>	weight	<input checked="" type="checkbox"/>	density	<input type="checkbox"/>

[Total 4 marks]

29. The diagram shows a man standing on a planet.

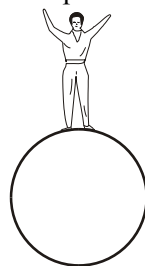

Complete and label two free-body force diagrams in the space below, one for the man and one for the planet.

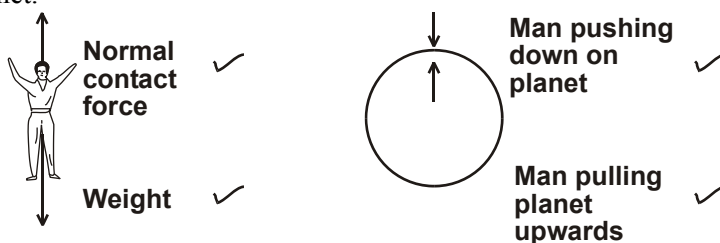

(4 marks)

The man is in equilibrium. Explain what can be deduced about the forces acting on the man.

**The two forces are equal in magnitude and opposite in direction.**

(1 mark)

[Total 5 marks]

30. The diagram shows a lorry on a bridge.

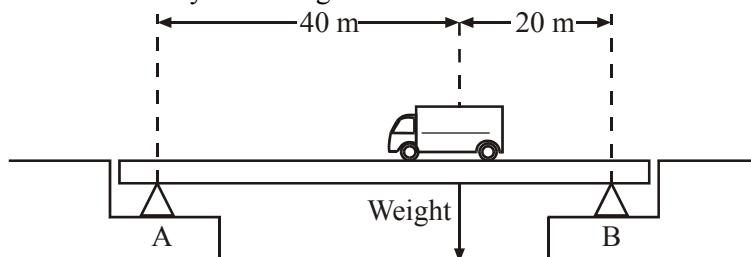

The total mass of the lorry is 45 000 kg. Calculate its weight.

$$\begin{aligned} \text{Weight} &= (45\,000\text{ kg})(9.81\text{ ms}^{-2}) \\ &= 441\,000\text{ N [or 441 kN]} \end{aligned}$$

(1 mark)

By taking moments about A, find the increase in the upward force provided by support B when the lorry is on the bridge and in the position shown in the diagram.

$$\begin{aligned} &\text{Increase in upward force at support B} \times (60\text{ m}) \\ &= (441\,000\text{ N}) \times (40\text{ m}) \text{ [or 441 kN]} \\ &= 294\,000\text{ N [or 294 kN]} \end{aligned}$$

(2 marks)

Calculate the corresponding increase in the force provided by support A.

$$\begin{aligned} &\text{Increase in upward force at support A} \\ &= 441\,000 - 294\,000 \text{ [or 4441kN - 294 kN]} \\ &= 147\,000\text{ N [or 147 kN]} \end{aligned}$$

(1 mark)

[Total 4 marks]

31. State Newton's second law of motion.

**Magnitude of forces proportional to rate of change of momentum (1) and direction of force same as the direction of the change in momentum (1).**

(2 marks)

You are asked to test the relation between force and acceleration.

Draw and label a diagram of the apparatus you would use.

**Diagram showing**

1. **how a range of quantifiable forces can be applied to a movable object of constant mass (1)**

**and**

2. **equipment suitable for measuring the acceleration (1).**

State clearly how you would use the apparatus and what measurements you would make.

**A statement of how the magnitude of the variable force is known. (1)**

**The identification of the distance and (1)**

**time measurements that could yield a value for the acceleration (1)**

**Repeat the acceleration measurements for different forces (1)**

**(6 marks)**

Explain how you would use your measurements to test the relationship between force and acceleration.

**Method of determining the acceleration from the distance and time measurements. (1)**

**Draw a graph of force against acceleration. (1)**

**Proportionality indicated by a straight line passing through the origin. (1)**

**(3 marks)**

**[Total 11 marks]**

32. A semiconducting strip, 6 mm wide and 0.5 mm thick, carries a current of 8 mA. The carrier density is  $7 \times 10^{23} \text{ m}^{-3}$ . Calculate the carrier drift speed.

**Drift speed  $v = I/nAq$  (1)**

$$\frac{8 \times 10^{-3} \text{ A}}{(7 \times 10^{23} \text{ m}^{-3})(3 \times 10^{-6} \text{ m}^2)(1.6 \times 10^{-19} \text{ C})} \quad (1)$$

**Drift speed  $24 \times 10^{-3} \text{ m s}^{-1}$  (1)**

**(3 marks)**

An approximate value for the drift speed in a copper wire of the same dimensions and carrying the same current would be about  $10^{-7} \text{ m s}^{-1}$ . Compare this figure with your calculated result and account for any difference in terms of the equation  $I = nAqv$ .

**The drift speed in the copper wire is much lower (1)**

**but  $I$ ,  $A$  and  $q$  are the same the two specimens (1)**

**$n$  must be much larger in copper than in the semiconducting material (1)**

**(3 marks)**

Explain why the resistance of a semiconducting strip decreases when its temperature rises.

**The carrier density in the semiconductor increases with temperature (1)**

**because the stronger thermal vibrations release more electron-hole pairs (1)**

**(2 marks)**

**[Total 8 marks]**

33. The “engine” of a hang-glider is the gravitational field of the Earth. Hang-gliders drop slowly through the air during their flight. The weight of a reasonably efficient hang-glider, including the pilot, is about 900 N. When the forward flight speed has a steady value of  $18 \text{ m s}^{-1}$ , the sinking speed is approximately  $1.2 \text{ m s}^{-1}$ .

Calculate the decrease in potential energy per second.

**Decrease in potential energy per second = weight  $\times$  weight loss per second  
= (900 N)(1.2 m) (1)**

**Decrease = 1.08 kJ (1)**

Explain what happens to this potential energy.

**It is mostly transferred to the surroundings (1)**

**in the form of increased thermal energy. (1)**

**(4 marks)**

The maximum steady power output of a fit racing cyclist over several hours is about 400 W. Explain why sustained man-powered flight is difficult to achieve.

**The shortfall in power (1080 W – 400 W) (1)  
is more than the man can provide over a long-enough period for  
sustained flight (1)**

**(2 marks)  
[Total 6 marks]**

34. Radon -220 (also known as thoron) is a radioactive gas which decays by  $\alpha$  emission to polonium  $^{216}_{84}\text{Po}$ . The half-life of this decay is approximately 1 minute.

Write a nuclear equation for this decay.

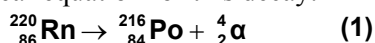

**(1 mark)**

Describe an experiment you could perform in a school laboratory to determine the half-life of an  $\alpha$  emitter of half-life approximately 1 minute.

**An appropriate set up for detecting  $\alpha$  radiation. (1)**

**Measurement of successive count rates. (1)**

**At 10-20 second intervals OR total duration  $\leq 5$  min. (1)**

**G-M tube methods: take background into account OR  
ionisation chamber: calibrate meter. (1)**

**Plot appropriate graph (1)**

**Measure  $t_{1/2}$  directly OR find gradient of  $\ln$  graph. (1)**

**Repeat for different coordinates OR  $t_{1/2} = \ln 2 / \text{gradient}$  (1)**

**ANY 5 POINTS**

**(5 marks)**

A sample of milk is contaminated with a very small quantity of strontium -90. This isotope decays by  $\beta^-$  emission with a half-life of approximately 28 years.

Give two reasons why it would be very difficult to use this contaminated sample of milk to obtain an accurate value for the half-life of strontium-90.

**Count rate so low, difficult to distinguish from background radiation  
OR from random fluctuations (1)**

**Very slow change in count rate difficult to detect over normal experimental  
times (1)**

**$\beta^-$  absorbed within sample. (1)**

**Any two points**

**(2 marks)  
[Total 8 marks]**

35. Two identical table tennis balls, A and B, each of mass 1.5 g are attached to non-conducting threads. The balls are charged to the same positive value. When the threads are fastened to a point P the balls hang as shown in the diagram. The distance from P to the centre of A or B is 10.0 cm.

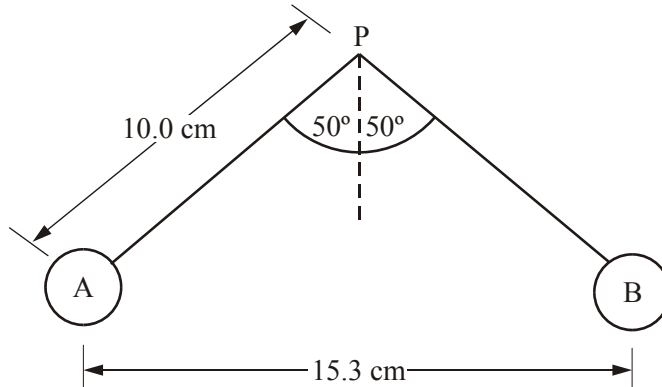

Draw a labelled free-body force diagram for ball A.

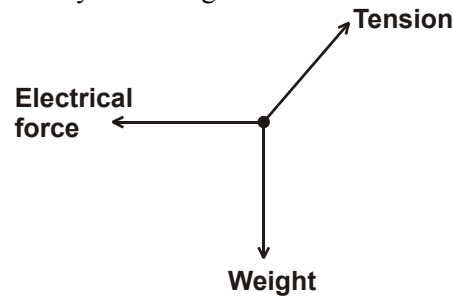

(3 marks)

Calculate the tension in one of the threads.

$$\begin{aligned} T \cos 50 &= mg \quad (1) \\ &= (1.5 \times 10^{-3} \text{ kg}) (9.81 \text{ N kg}^{-1}) \quad (1) \\ \text{Tension} &= 2.3 \times 10^{-2} \text{ N} \quad (1) \end{aligned}$$

(3 marks)

Show that the electrostatic force between the two balls is  $1.8 \times 10^{-2} \text{ N}$ .

$$F_E = (2.3 \times 10^{-2} \text{ N}) \sin 50 = 1.8 \times 10^{-2} \text{ N} \quad (1)$$

(1 mark)

Calculate the charge on each ball.

$$\begin{aligned} F_E &= k \frac{q_1 q_2}{d^2} \quad (1) \\ 1.8 \times 10^{-2} \text{ N} &= \frac{q^2}{4\pi\epsilon_0 \times (1.53 \times 10^{-2} \text{ m})^2} \quad (1) \\ \text{Charge} &= 2.1 \times 10^{-7} \text{ C} \quad (1) \end{aligned}$$

(3 marks)

How does the gravitational force between the two balls compare with the electrostatic force given opposite?

**It is very much smaller than the electrostatic force or a correctly calculated value. (1)**

**Gravitational force is attractive. (1)**

**(2 marks)**  
**[Total 12 marks]**

36. The diagram (not to scale) shows a satellite of mass  $m$ , in circular orbit at speed  $v_s$  around the Earth, mass  $M_E$ . The satellite is at a height  $h$  above the Earth's surface and the radius of the Earth is  $R_E$ .

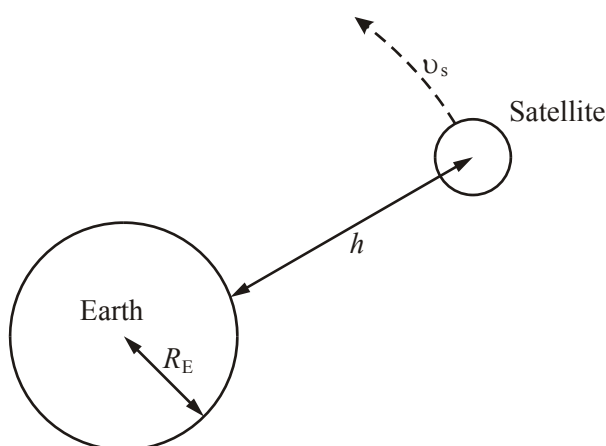

Using the symbols above write down an expression for the centripetal force needed to maintain the satellite in this orbit.

$$F = \frac{m_s v_s^2}{R_E + h} \quad (2)$$

**(2 marks)**

Write down an expression for the gravitational field strength in the region of the satellite.

$$g = \frac{GM_E}{(R_E + h)^2} \quad (2)$$

State an appropriate unit for this quantity.

$$\mathbf{N \, kg^{-1}} \quad (1)$$

**(3 marks)**

Use your two expressions to show that the greater the height of the satellite above the Earth, the smaller will be its orbital speed.

$$\frac{m_s v_s^2}{R_E + h} = \frac{GM_E m_s}{(R_E + h)^2} \quad (1)$$

$$v_s^2 = \frac{GM_E}{R_E + h} \quad (1)$$

**Greater  $h$   $\Rightarrow$  smaller  $v_s$  since  $G, M_E$  constant (1)**

**(3 marks)**



Explain why, if a satellite slows down in its orbit, it nevertheless gradually spirals in towards the Earth's surface.

**As it slows**  $\frac{GM_E m_s}{(R_E + h)^2} > \frac{m_s v_s^2}{R_E + h}$  (1)

**The "spare" gravitational force not needed to provide the centripetal acceleration pulls the satellite nearer to the Earth** (1)

(2 marks)  
[Total 10 marks]

37. Write down a word equation which defines the magnitude of a force.

**Force = mass × acceleration** (2)

(2 marks)

Two forces have equal magnitudes. State three ways in which these two equal forces can differ.

**Direction** (1)

**Act on different bodies** (1)

**Forces of different kinds** (1)

**Point of application/lines of action** (1)

**Act at different times/different durations** (1)

(Any three)

(3 marks)  
[Total 5 marks]

38. Demonstrate that the following equation is homogeneous with respect to units. The symbols have their usual meanings.

$$x = ut + \frac{1}{2} at^2$$

**Show that  $ut$  is in metre** (1)

**Show that  $\frac{1}{2} at^2$  is in metre** (1)

(2 marks)

The following graph shows the speed  $v$  of a body during a time interval of just 3 seconds.

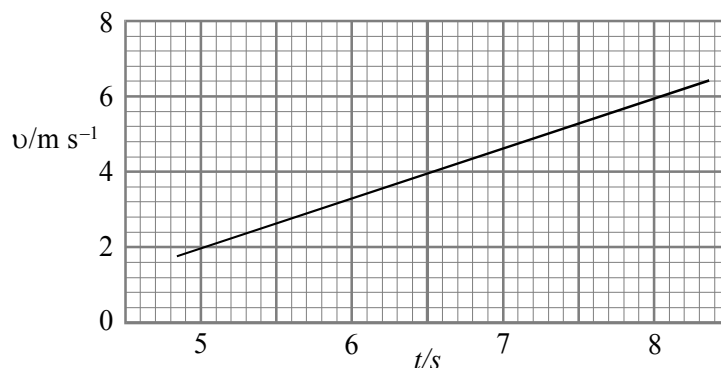

Use the graph to determine the magnitude of the acceleration  $a$ .

**Acceleration  $a$  = gradient of graph** (1)

$$= (4.0\ ms^{-2}) / (3.0s) \quad (1)$$

**Acceleration =  $1.3\ ms^{-2}$**  (1)

(3 marks)

Find the distance travelled by the body between  $t = 6$  s and  $t = 8$  s..

**distance travelled = area between graph & time axis (1)**

**=  $(4.67 \text{ ms}^{-1}) \times (2.0\text{s})$**

**Distance = 9.3 m (1)**

**(2 marks)**

**[Total 7 marks]**

39. The diagram on the left shows a crowbar being used to pull a nail out of a wooden floor.

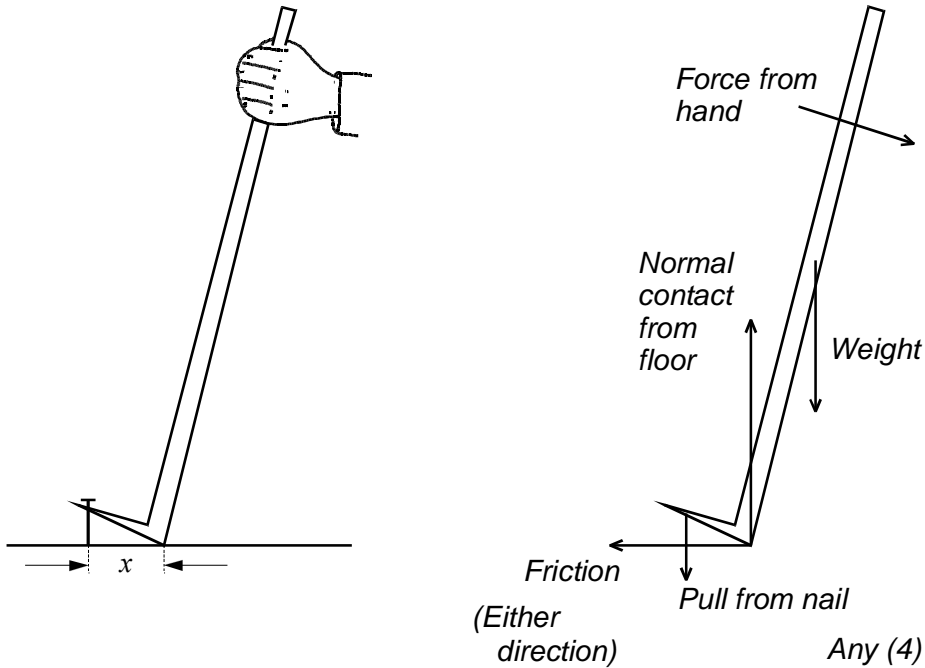

Any (4)

Use the diagram on the right to draw and to label a free-body force diagram for the crowbar. For each of the four forces which act on the crowbar, show the line of action, the direction and the source.

**(4 marks)**

Identify one of the above forces which is not involved in an energy transfer process. Explain your answer.

**Friction or normal contact force from floor (1)**

**There is no movement in the direction of the force (1)**

**(2 marks)**

Give one advantage and one disadvantage of keeping the distance  $x$  as small as possible.

Advantage **Greater leverage or alternative (1)**

Disadvantage **Nail pulled short distance or alternative (1)**

**(2 marks)**

**[Total 8 marks]**

40. Each of the following graphs can be used to describe the motion of a body falling from rest. (Air resistance may be neglected.)

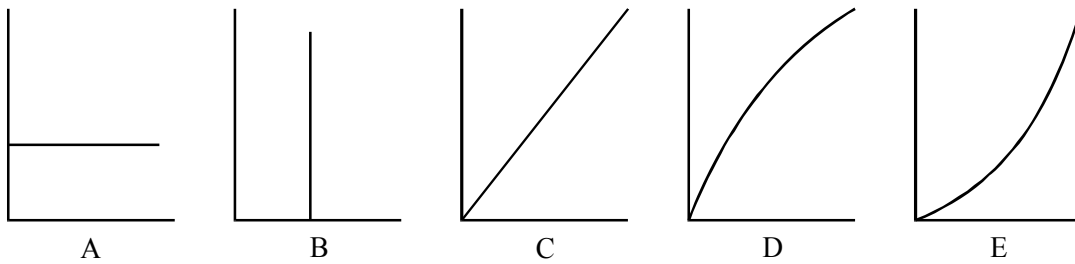

Which graph shows how the kinetic energy of the body ( $y$ -axis) varies with the distance fallen ( $x$ -axis)?

Graph **C** (1)

Explain your answer.

**Since kinetic energy gained = potential energy lost, (1)**

**Kinetic energy gained  $\propto$  distance fallen (1)**

**(3 marks)**

Which graph shows how the distance fallen ( $y$ -axis) varies with the time ( $x$ -axis)?

Graph **E** (1)

Explain your answer.

**Speed increases with time (1)**

**So gradient increases with distance (1)**

**(3 marks)**

Which graph shows the relationship between acceleration ( $y$ -axis) and distance ( $x$ -axis)?

Graph **A** (1)

Explain your answer.

**Acceleration is constant (1)**

**throughout the motion (1)**

**(3 marks)**

**[Total 9 marks]**

41. You are given a piece of resistance wire. It is between two and three metres long and has a resistance of about  $15\Omega$ . You are asked to measure the resistivity of the metal alloy it is made from.

Make the necessary additions to the following circuit to enable it to be used for the experiment.

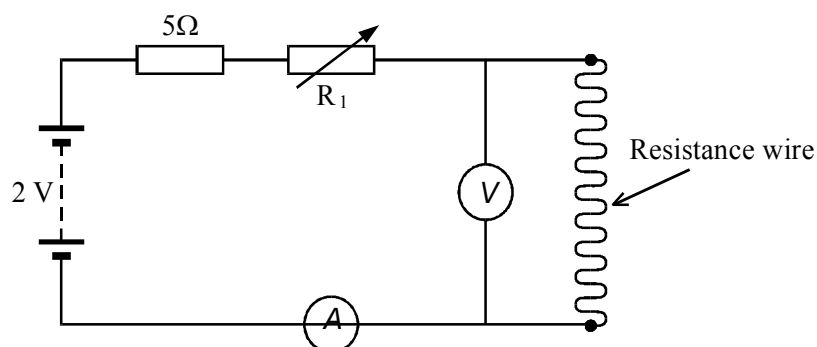

**(2 marks)**

Describe briefly how you would use the circuit above to measure the resistance of the wire.

**Record values of V and I (1)**

**for different values of V (1)**

**by changing  $R_1$  (1)**

**Draw a graph of V against I (1)**

**Resistance = gradient (1)**

**(5 marks)**

Once the resistance of the wire is known, two more quantities must be measured before its resistivity can be calculated. What are they?

**Length (1)**

**Diameter (1)**

**(2 marks)**

Is there any advantage in finding the resistance of the wire from a graph compared with calculating an average value from the measurements? Explain your answer.

**Allow any good reason for an implied 'yes' (z/o) (1)**

**Be ready to give full credit for an implied 'no' (1)**

**(2 marks)**

**[Total 11 marks]**

42. Classify each of the terms in the left-hand column by placing a tick in the relevant box.

**[Total 6 marks]**

43. State the principle of moments.

**For a body in an equilibrium state (1)**

**the sum of the clockwise moments equals the sum of the anticlockwise moments. (1)**

**(2 marks)**

The diagram shows a lorry on a light bridge.

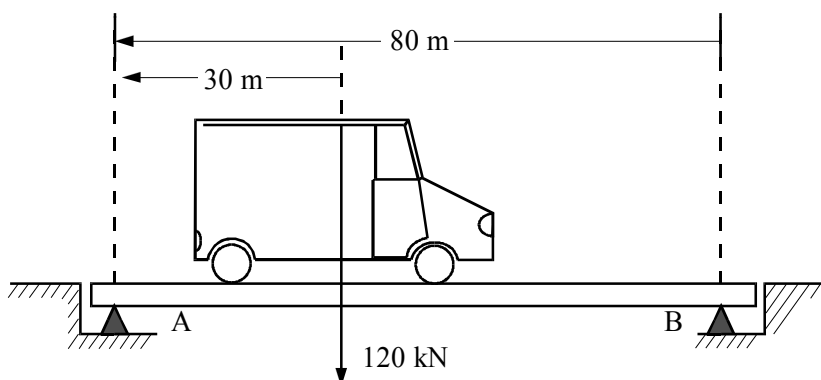

Calculate the downwards force on each of the bridge supports.

**$F_A \times (80\text{m}) = (120 \text{ KN}) \times (50 \text{ m})$  (1)**

**Force at A = 75 KN (1)**

**$F_B = (120 \text{ KN}) - F_A$  (1)**

**Force at B = 45 KN (1)**

**(4 marks)**

Sketch a graph on the axes below to show how the force on the support at A changes as the

centre of gravity of the lorry moves from A to B Mark the value of the intercept on the force axis.

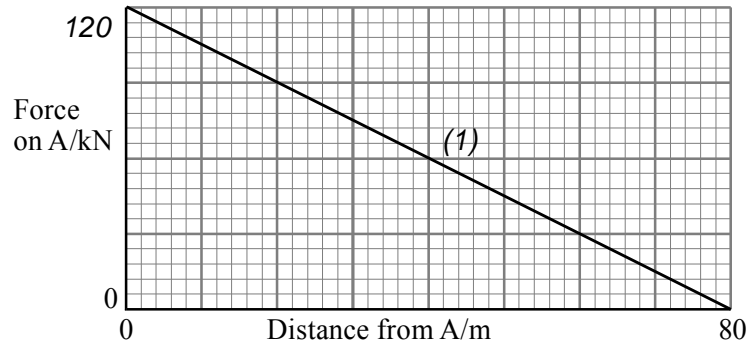

(3 marks)  
[Total 9 marks]

44. The diagram shows a smooth wooden board 30 cm long. One end is raised 15 cm above the other. A 100 g mass is placed on the board. The two forces acting on the 100 g mass are shown on the free-body force diagram.

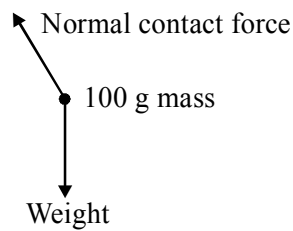
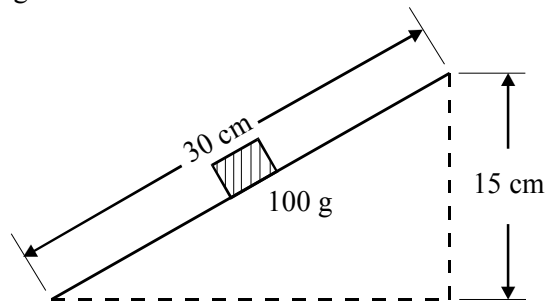

Explain with the aid of a sketch why the resultant force on the 100 g mass acts parallel to the board and downwards.

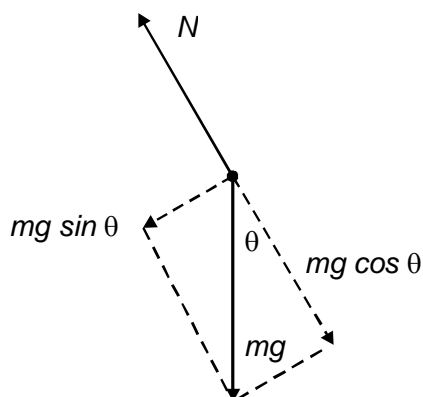

The normal contact force  $N$  balances  $mg \cos \theta$  (1)

$mg \sin \theta$ , an unbalanced force perpendicular to  $N$  acts down the plane. (1)  
(2 marks)

Calculate the magnitude of this resultant force.

$$mg \sin \theta = (0.100 \text{ kg}) 9.8 \text{ ms}^{-2} (0.5) \quad (1)$$

$$\text{Magnitude} = 0.49 \text{ N} \quad (1)$$

(2 marks)

Calculate the kinetic energy gained by the 100 g mass as it slides down 20 cm of the slope.

$$E_K = (0.49 \text{ N}) \times (0.20 \text{ m}) \quad (1)$$

$$\text{Kinetic energy} = 0.098 \text{ J} \quad (1)$$

(2 marks)

The smooth board is replaced by a similar rough board which exerts a frictional force of 0.19 N on the 100 g mass. Calculate the new value for the kinetic energy gained by the 100 g mass as it slides down 20 cm of slope.

$$E_K = (0.49 \text{ N} - 0.19 \text{ N}) \times (0.20 \text{ m}) \quad (1)$$

$$\text{Kinetic energy} = 60 \text{ m J} \quad (1)$$

(2 marks)

Explain why the final kinetic energy of the 100 g mass is greater when the board is smooth.

The work done against friction is smaller for the smooth board than for the rough board. (1)

So more of the energy transferred is transformed into kinetic energy. (1)

(2 marks)

[Total 10 marks]

45. A student carries out an experiment to determine the half-life of a radioactive isotope M. After subtracting the mean background count from the readings, the student plots the smooth curve shown on the graph below.

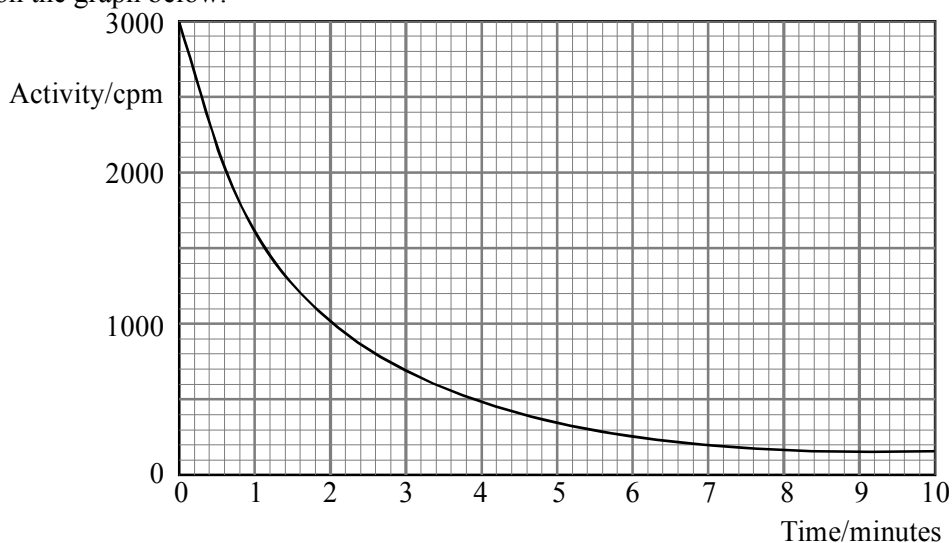

From this graph the student concludes that the isotope M is not pure, but contains a small proportion of another isotope C with a relatively long half-life.

State a feature of the graph that supports this conclusion.

**Graph has flattened off after 7 minutes OR non-consistent half-life. (1)**

**(1 mark)**

Estimate the activity of isotope C.

**150 cpm (1)**

**(1 mark)**

Determine the half-life of isotope M. Show clearly how you obtained your answer.

**Allow for 150 (1)**

**Two sets of readings averaged (1)**

**Half-life of M = 1.2 minutes (1)**

**(3 marks)**

Isotope M decays by  $\beta^-$  emission. Write down a nuclear equation showing how the  $\beta^-$  particles are produced.

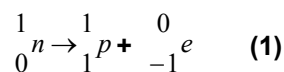

**(1 mark)**

Describe briefly how the student could determine the nature of the radiation emitted by isotope C.

**Wait until M has decayed (1)**

**Set up discussion about use of paper leading to  $\alpha$  (1)**

**Ditto to  $\beta$  (1)**

**OR**

**Use range in air arguments to distinguish  $\alpha$  from  $\beta$  [can score marks using  $\gamma$ ]**

**OR**

**Any other acceptable experiment.**

**(3 marks)**  
**[Total 9 marks]**

46. The diagram shows a positively charged oil drop held at rest between two parallel conducting plates A and B.

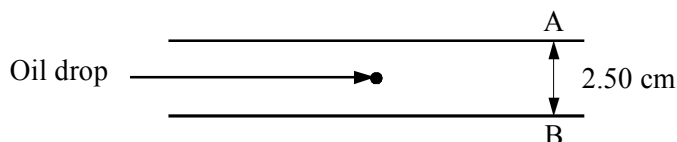

The oil drop has a mass  $9.79 \times 10^{-15}$  kg. The potential difference between the plates is 5000 V and plate B is at a potential of 0 V. Is plate A positive or negative?

**Negative (1)**

Draw a labelled free-body force diagram which shows the forces acting on the oil drop. (You may ignore upthrust).

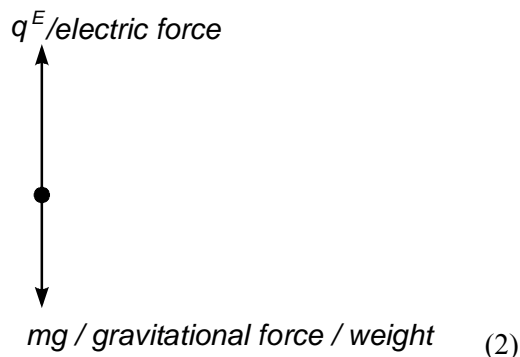

**(3 marks)**

Calculate the electric field strength between the plates.

$$E = \frac{5000V}{2.50 \times 10^{-2}m} \quad (1)$$

$$\text{Electric field strength} = 2 \times 10^5 \text{ V m}^{-1} \text{ [OR N C}^{-1}\text{]} \quad (1)$$

**(2 marks)**

Calculate the magnitude of the charge Q on the oil drop.

$$Mg = qE: \text{ use of equation} \quad (1)$$

$$\text{Charge} = 4.8 \times 10^{-19} \text{ C} \quad (1)$$



How many electrons would have to be removed from a neutral oil drop for it to acquire this charge?

**3 (1)**

**(3 marks)**  
**[Total 8 marks]**

47. A ball rolls over an obstacle which has been placed on a flat horizontal surface. The diagrams opposite show a velocity-time graph, a displacement-time graph and the axes for an acceleration-time graph for the horizontal motion of the ball. The time axes for the three graphs are identical.

Calculate the changes of displacement during the time intervals (i)  $t = 0$  to  $t = X$  and (ii)  $t = X$  to  $t = Y$ .

(i)  **$(4 \text{ ms}^{-1} \times 0.5 \text{ s})$**

**$0X = 2\text{m}$  (1)**

(ii) **Relevant equation of motion or  $3 \text{ ms}^{-1} \times 0.5 \text{ s}$  or attempt to find area**  
**(1)**

**$XY = 1.5 \text{ m..}$  (1)**

Add in the scale values for the displacement axis on the second graph.

**Allow mark for isolated correct value and no wrong values (1)**

Sketch the acceleration-time graph and add the scale values to the acceleration axis.

**Correctly placed hollow (1)**

**Correctly placed hump (1)**

**Correct rectangular shapes (1) (+4 and | or -4)  $\text{ms}^{-2}$  (1)**

Sketch the shape of a vertical cross-section of the obstacle (without showing any of the dimensions) in the space below.

**(2 marks)**

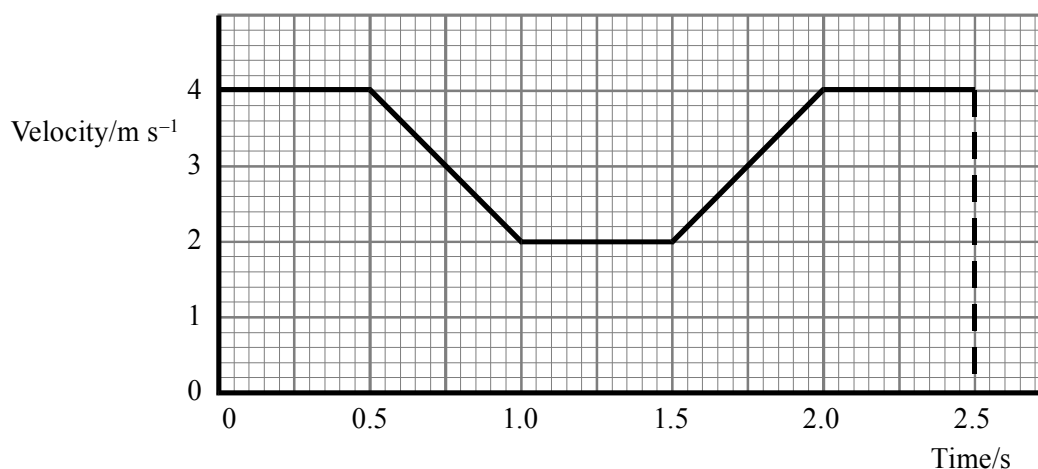
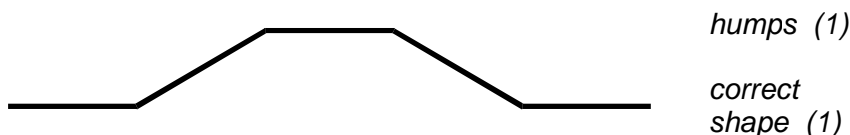

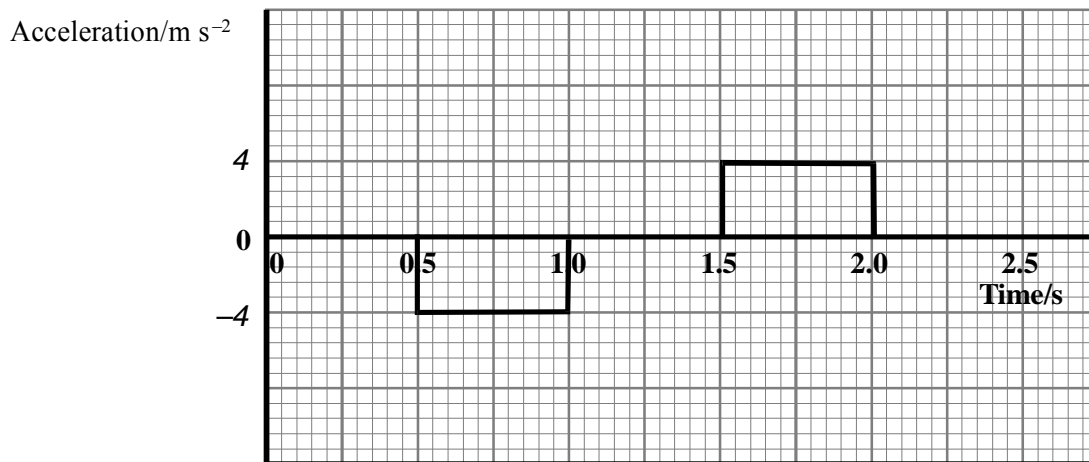
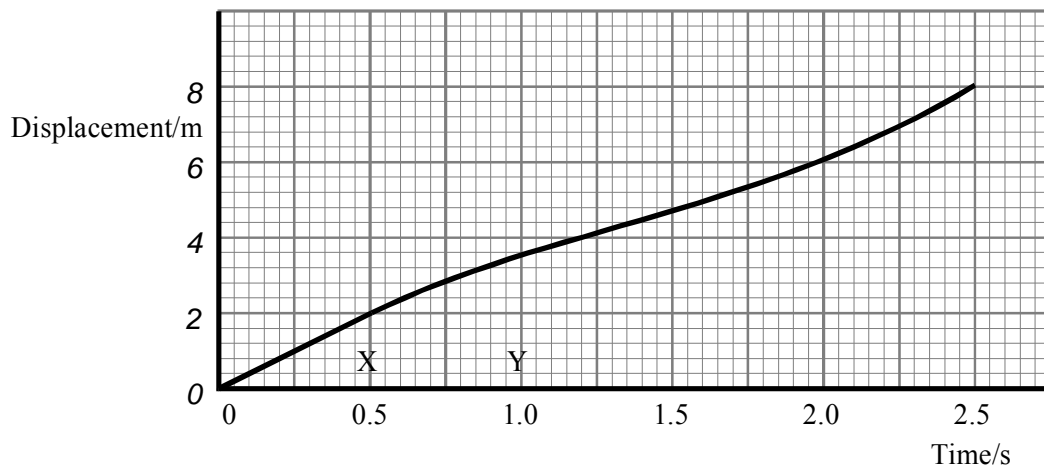

[Total 10 marks]

48. State the difference between scalar and vector quantities.

**Scalar quantities are non-directional (1)**

**Vector quantities are direction (1)**

A lamp is suspended from two wires as shown in the diagram. The tension in each wire is 4.5N.

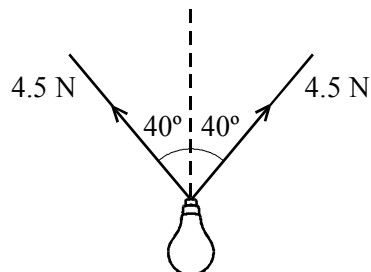

Calculate the magnitude of the resultant force exerted on the lamp by the wires.

**$4.5 \text{ N} \cos 40^\circ$  (1)**

**$\times 2$  (1)**

**Resultant force = 6.9 N (1)**

What is the weight of the lamp? Explain your answer.

**6.9 N (1)**

**Weight = Supporting force or it is in equilibrium (1)**

**[Total 7 marks]**

49. The diagram shows an old-style chemical balance. The total mass of the moving part (i.e arm, pointer and two scale pans) is 128 g and when the pointer is vertical the centre of mass is 3.0 cm vertically below the pivot.

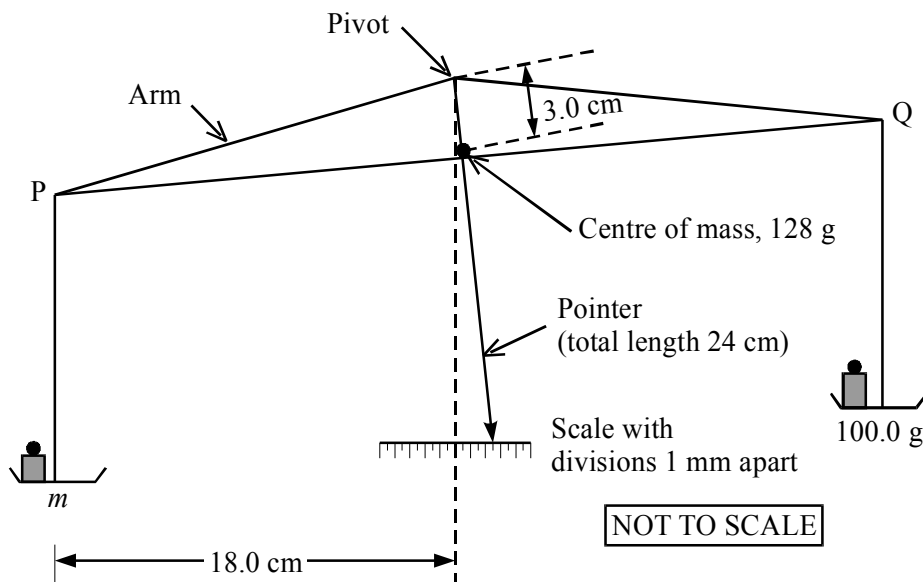

The pointer, which is 24.0 cm long, moves over a scale whose divisions are 1.0 mm apart. The pointer is deflected five scale divisions to the right.

Show that the horizontal displacement of the centre of mass is 0.625 mm.

**Identifying 8:1 ratio or Deflection = 1.194° (1)**

**5 mm/8 (allow 2.5 mm/8) 30 mm tan (1.194°) (1)**

**0.625 mm (allow 0.3125 mm) (1)**

The mass in the right-hand scale pan is 100.0 g. Assume that the horizontal distance of P and Q from the pivot are constant. Calculate the mass  $m$  in the left-hand scale pan.

**$m \times (18 \text{ cm})$  (1)**

**$= (100.0 \text{ g}) (18 \text{ cm}) + (128 \text{ g}) (0.0625 \text{ cm})$  (1)**

**{Allow 100.2 g if 0.3125 mm is used}**

**Mass  $m = 100.4 \text{ g}$  (1)**

Explain why the scale over which the pointer moves is not calibrated.

**The calibration of the scale changes (1)**

**If the masses on the scale pans change (1)**

**(2/0)**

**[Total 8 marks]**

50. It is thought that an extremely short-lived radioactive isotope  ${}_{110}^{269}\text{X}$ , which decays by  $\alpha$ -emission, has a half-life of 200  $\mu\text{s}$ .

After a series of  $\alpha$  decays the element  ${}_{104}^{\text{A}}\text{Y}$  is formed from the original isotope. There are no  $\beta$  decays.

Deduce the value of A.

$$\alpha\text{-particle is } \frac{4}{2} \text{? (1)}$$

$$\text{A} = 257 \text{ (1)}$$

Calculate the decay constant  $\lambda$  of  ${}_{110}^{269}\text{X}$ .

$$\lambda = 3.5 \times 10^3 \text{ s}^{-1} \text{ (1)}$$

The number of nuclei  $N$  of  ${}_{110}^{269}\text{X}$  in a sample of mass 0.54  $\mu\text{g}$  is  $1.2 \times 10^{15}$ . Determine the activity of 0.54  $\mu\text{g}$  of  ${}_{110}^{269}\text{X}$

$$\text{Substitute in } \frac{dN}{dt} = -\lambda N \rightarrow -3.5 \times 10^3 \text{ s}^{-1} \times 1.2 \times 10^{15} \text{ (1)}$$

$$\text{Activity} = 4.2 \times 10^{18} \text{ Bq (1)}$$

Why is this value for the activity only approximate?

$\lambda$  calculated from  $t_{1/2}$  which is very short so difficult to measure OR  
radioactivity is a random process so only average values of  $t_{1/2}$  /  $\lambda$  known. (1)

[Total 6 marks]

51. (a) Upward/electrical force equals/balances weight (1)

$$EQ = mg \text{ (1)}$$

$$E = \frac{V}{d} = \frac{500\text{V}}{5.8 \times 10^{-3} \text{ m}} \text{ (1)}$$

$$= 8.62 \times 10^4 \frac{\text{V}}{\text{m}} / \frac{\text{N}}{\text{C}}$$

$$= mg = (1.4 \times 10^{-14} \text{ kg}) (9.8 \text{ N kg}^{-1}) \text{ (1)}$$

$$= 1.37 \times 10^{-13} \text{ N}$$

$$\Rightarrow Q = \frac{1.37 \times 10^{-13} \text{ N}}{8.62 \times 10^4 \text{ NC}^{-1}} = 1.59 \times 10^{-18} \text{ C (1)}$$

Horizontal: so that two forces/ $EQ$  and  $mg$  are parallel (1)

6

- (b)  $\beta$  source emits electrons (1)  
which ionise air (molecules) (1)

Positive ions are attracted to sphere (1)

Free-body diagram showing upward drag/resistive force (1)

Max 3

- (c) Quantised: charge comes in lumps/discrete amounts/packets (1)

Other: energy/electro-magnetic wave (energy)/light (1)

Situation: photoelectric effect/spectra/energy levels (1)

Description of how the situation chosen shows quantisation (1)

4

- (d) Spheres are being hit/bombarded (1)  
 by air molecules/particles (1)  
 which are in random motion (1)

[Max 1 for simply Brownian motion]

Lower temperature: air molecules' speed/kinetic energy is reduced (1)

**Max 3**

**52.** Magnitude of force  $A$  compared to weight of block and explanation:

- Force  $A >$  weight of block (1)  
 Because block is thrown upwards  
 Or net upward force on block  
 Or satisfactory alternative (1)

Labels for forces  $F$  and  $C$ :

- Force  $F =$  push of mallet (1)  
 Force  $C =$  push from iron bar (OR pivot) (1)

**4**

Impulse applied to block:

- Area correctly indicated (eg within calculation) (1)  
 Impulse = 9 N s (1)

Maximum upward speed of block:

$$\text{Upward speed} = \frac{\text{momentum}}{\text{mass}} = \frac{9 \text{ N s}}{7.1 \text{ kg}} \quad (1)$$

$$\text{Speed} = 1.3 \text{ m s}^{-1} \quad (1)$$

Why forces unequal:

- The force from the board is opposed by the weight of the block  
 [Any satisfactory statement will include the idea of a 2<sup>nd</sup> force] (2)

**6**  
**[Total 10 marks]**

- 53.** (i) Displacement = area to left of 1.5 s (1)  
 = 23.8 m [Range 22 m - 26 m] (1)

**2**

- (ii) Acceleration = gradient of tangent  
 = values taken from graph (1)  
 = 15 m s<sup>-2</sup> → 24 m s<sup>-2</sup> (1)

**2**

[Methods based on equations of motion are invalid.  
 Acceleration is not constant.]

- (iii) Kinetic energy =  $\frac{1}{2} \times 420 \text{ kg} (62 \text{ m s}^{-1} - 63 \text{ m s}^{-1})^2$  (1)  
 0.80 MJ → 0.84 MJ (1)

**2**

[NB The permitted rounding error is on the generous side]

**[Total 6 marks]**

54. Explanation:

Identify the timing device (1)

Define time interval to be measured (1)

Either check length of truck value

or significant detail of timing process (1)

Speed = length of truck/time interval (1)

4

[2 max for correct description of the measurement of the wrong average speed, e.g. from A to B]

3 max for measuring an instantaneous speed

Calculation:

Either:

$$\text{Acceleration} = \frac{v^2 - u^2}{2s} = \frac{[(1.64 \text{ ms}^{-1})^2 - (1.52 \text{ ms}^{-1})^2]}{2 \times (1.20 \text{ m})} \quad (1)$$

$$= 0.158 \text{ m s}^{-2} \quad (1)$$

Or

$$\text{Time interval } t = \frac{2s}{v + u} = \frac{2 \times (1.20 \text{ m})}{(1.64 \text{ m s}^{-1}) + (1.52 \text{ m s}^{-1})} \quad (1)$$

$$= 0.76 \text{ s} \quad (1)$$

$$\text{Acceleration} = \frac{v - u}{t} = 0.158 \text{ m s}^{-2} \quad (1)$$

2

[Total 6 marks]

55. Work = force  $\times$  displacement (1)

in direction of force (1)

2

[ $W = F \times d$  or similar gets zero]

Explanation:

Kinetic energy of particle is constant (1)

Work done on particle is zero (1)

Distance moved by particle in direction of force is zero (1)

Direction of motion must be at right angles to direction of force (1)

Max 3

Diagram:

Identify velocity change ( $v_B - v_A$ ) (1)

and its direction (perpendicular to AB and towards left) (1)

Hence acceleration is towards centre (1)

3

[Total 8 marks]

56. Joule:  $\text{kg m}^2 \text{ s}^{-2}$  (1)

Coulomb: Derived unit (1)

Time: Scalar quantity (1)

Volt:  $\text{W} \times \text{A}^{-1}$  (1)

[Total 4 marks]

57. Incoming particle:  $\alpha$ -particle (1)  
 Target atoms: gold atoms (1)
- Conclusion about atomic structure:  
 Most of the volume of the atom is space (1)  
 The atom contains a small dense (relatively massive) centre (1)
- Diameters:  
 $10^{-15}$  m is diameter of nucleus (1)  
 $10^{-11}$  m is diameter of atom (1)

[Total 6 marks]

58. Deduction of properties of  $\alpha$ -particles from photograph:

Any four of

- They are charged/highly ionising (1)
- They all have the same energy (1)
- They are of two distinct energies (1)
- They are short range (1)
- They travel in straight lines/have "large" mass (1)

4

Use of Geiger counter:

- Take a reading very close to the source:  $C_1$  (1)
- Take a second reading through a sheet of paper:  $C_2$
- (Or at a distance 5 cm - 10 cm further)  $C_\alpha = C_1 - C_2$  (1)

2

[Total 6 marks]

59. Force A Lift: higher pressure below wing than above (1)  
 Force B Weight: earth's  $g$  field acting on mass of plane (1)  
 Force C Drag: resistance of air to motion of the plane (1)  
 Force D Thrust: reaction to exhaust gases (1)

4

Resultant force is zero (1)

- Because: Straight line motion at constant speed  
 or zero acceleration  
 or satisfactory alternative (1)

2

[Total 6 marks]

60. Energy given out =  $mc\Delta\theta$  (1)  
 =  $(1.2 \times 1000 \text{ kg})(4200 \text{ J kg}^{-1} \text{ K}^{-1})(98 \text{ }^\circ\text{C} - 65 \text{ }^\circ\text{C})$  (1)  
 Energy = 166 MJ (1) 3
- Time =  $\frac{\text{Energy}}{\text{Power}} = \frac{W}{P}$  (1)  
 =  $\frac{1.66 \times 10^8 \text{ J}}{6 \times (1.5 \times 10^3 \text{ W})}$  (1)  
 Time = 18 400 s/307 min/5.1 h (1) 3  
 [Do not penalise modest rounding differences]
- Any two of the following:  
 Temperature difference greater in morning than evening (1)  
 Clear reasons (1)  
 $\therefore$  greater output in morning than evening (1) 2  
**[Total 8 marks]**
61. Description of force C which forms a Newton's third law pair with A  
 Man pulling Earth upwards  
 with a gravitational force 2
- Similarities and differences  
*Similarities* [any 3]:  
 Magnitudes or equal  
 Kind (or type) of force *or* gravitational forces  
 Line of action [but **not** same plane, or point, or parallel]  
 Time interval or duration  
 Constant [not true in general but true in this instance] Max 3
- Differences:*  
 On different bodies [must say "bodies" or equivalent]  
 Direction [again, it answers this particular question] or opposite 2
- Two forces which show whether *or* not man is in equilibrium:  
 A and B 1
- [8]**
62. Calculation of total amount of energy released during flight:  
 $1.71 \times 10^5 \text{ litres} \times (38 \text{ MJ litre}^{-1})$   
 =  $6.5 \times 10^6 \text{ MJ}$  2
- Calculation of input power to engines:  
 $6.5 \times 10^{12} \text{ J} \div (47 \times 3600 \text{ s})$  [Allow e.c.f for energy released]  
 = 38 MW 2
- Calculation of aircraft's average speed:  
 $(41\,000 \text{ km}) \div (47 \text{ h})$  *or*  $(41 \times 10^6 \text{ m}) / (47 \times 3600 \text{ s})$   
 =  $870 \text{ km h}^{-1}$  *or*  $240 \text{ m s}^{-1}$   
 Multiply *maximum* thrust by average speed and comment on answer:



One engine:  $(700 \text{ kN} \times 870 \text{ km h}^{-1})$  or  $(700 \text{ kN} \times 240 \text{ m s}^{-1})$

Two engines:  $(2 \times 700 \text{ kN} \times 870 \text{ km h}^{-1})$   
or  $(2 \times 700 \text{ kN} \times 240 \text{ m s}^{-1}) = 340 \text{ MW}$

[Allow any correct unit with corresponding arithmetic, eg  $\text{kN km h}^{-1}$ ]

Statement recognising that the product is a power.

Either a comparison of the two powers or a comment on the engine thrusts. 6

[10]

63. Calculation of time bullet takes to reach top of its flight and statement of any assumption made:

$$-9.8 \text{ m s}^{-2} = (0 \text{ m s}^{-1} - 450 \text{ m s}^{-1})/t$$

$$t = 46 \text{ s}$$

Assumption: air resistance is negligible, acceleration constant or equivalent 3

Sketch of velocity-time curve for bullet's flight:

Label axes

Show the graph as a straight line inclined to axis

+  $450 \text{ m s}^{-1}$  and 46 s shown correctly

-  $450 \text{ m s}^{-1}$  or 92 s for a correctly drawn line

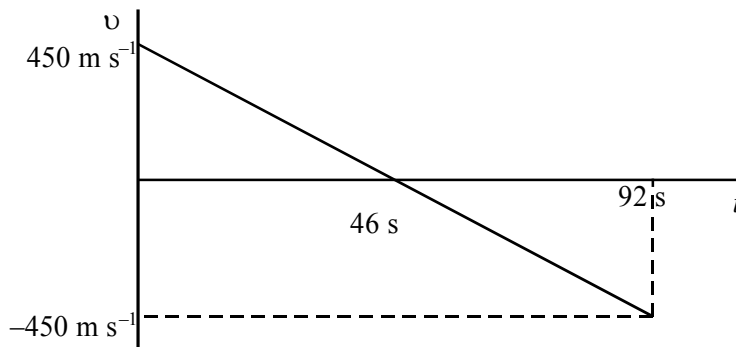

Explanation of shape of graph:

Why the line is straight - acceleration constant

or equivalent or why the velocity changes sign

or why the gradient is negative

Calculate the distance travelled by bullet, using graph:

Identification of distance with area between graph and time axis or implied in calculation

20 700 m for  $g = 9.8 \text{ ms}^{-2}$  or alternative answers from different but acceptable "g" values. 7

[Allow e.c.f with wrong time value.]

[10]

64. Type of radioactive decay  
 $\alpha$ -decay

Nuclear equation for decay

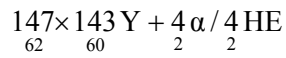

[1 mark for letters, 1 mark for numbers]

Addition of arrow to diagram

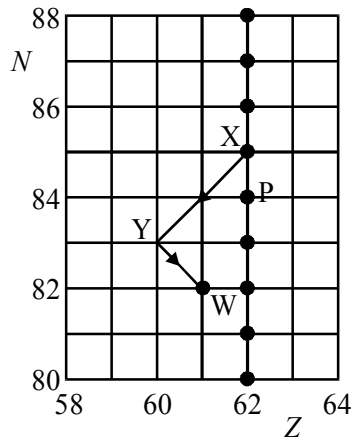

Point P on diagram

[5]

65. Design of experiment to find what types of radiation are emitted:

Soil in container with opening facing detector

Take background count /or shield apparatus

With detector close to soil, insert paper

or take close reading then at,  $\approx + 5$  cm; count rate reduced so  $\alpha$  present

Insert aluminium foil: further reduction  $\therefore \beta$  present

Insert lead sheet: count rate still above background or count rate reduced to zero,  $\therefore \gamma$  present.

or, if no count after aluminium foil, no  $\gamma$

or, if count rate above background with *thick* aluminium, then  $\gamma$  present

[5]

66. (a) Newton's second law implied  
 Idea of push of  $\text{CO}_2$  gases on system  
 Idea of system pushes out gases/Newton's third law  
 Newton's third law implied

Max 3

- (b) (i) Conservation of momentum stated  
 $(0.012 \text{ kg})v = (0.68 \text{ kg})(2.7 \text{ m s}^{-1}) / (0.668 \text{ kg})(2.7 \text{ m s}^{-1})$   
 $\rightarrow v = 153 \text{ m s}^{-1} / 150 \text{ m s}^{-1}$   
 Assume all  $\text{CO}_2$  small/no drag

4

- (ii) Kinetic energy  $\text{CO}_2 = \frac{1}{2} (0.012 \text{ kg}) (153 \text{ m/s})^2 / (150 \text{ m/s})^2$   
 $= 140 \text{ J}/135 \text{ J}$   
 Kinetic energy trolley  $= \frac{1}{2} (0.68 \text{ kg})(2.7 \text{ m/s})^2 / \frac{1}{2} (0.668 \text{ kg})(2.7 \text{ m/s})^2$   
 $= 2.5 \text{ J}/2.4 \text{ J}$  3
- (c) (i) energy is needed to evaporate  $\text{CO}_2$  go gaseous/latent heat  
 and this energy is taken from the system
- (ii) Use a thermocouple/thermistor  
 Difficulty: time delay in registering/thermal contact
- (iii) Measure mass of cylinder  
 Look up s.h.c. of cylinder (material) 6

**[16]**

67. What is meant by “an equation is homogeneous with respect to its units”:  
Each side/term has the same units 1

Equation  $x = ut + \frac{1}{2} at^2$ :

$$ut - (\text{m s}^{-1}) \text{ s} = \text{m}$$

$$at^2/2 (\text{m s}^{-2}) \text{ s}^2 = \text{m}$$

all 3 terms reduce to m 3

[Allow dimensions]

Explanation:

Wrong numerical constant/wrong variables

Units same, numbers wrong/

Units same, magnitudes wrong 1

Example = 1 kg + 2 kg = 5 kg

**[5]**

68. Magnitude of force  $Y$ :  
 $[g = 9.8 \text{ or } 10 \text{ m s}^{-2}]$   
 98 N [NOT 10 g] 1

Explanation of why  $X$  and  $P$  must have equal magnitude:  
 For equilibrium/for no (horizontal) motion/stays in place 1

Moment of the weight of cupboard about point A:

$$= 10 \text{ kg} \times 9.81 \text{ N kg}^{-1} \times 0.15 \text{ m} \text{ [formula and substitution] (e.c.f.)}$$

$$= 14.715 \text{ N m}$$

$$= 15 \text{ N m} \text{ [Do NOT accept J as alternative to N m]} 2$$

Value of force  $X$ :

$$0.60X = 14.715 \text{ [formula and substitution] (e.c.f.)}$$

$$X = 25 \text{ N} 2$$

Sketch graph:

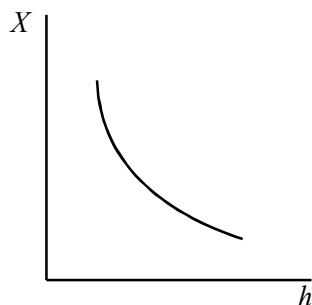

Axes labelled and line with negative gradient  
Correct curve [intercepts ignored]

2

Explanation:

So  $X$  is as small as possible

Screws less likely to be pulled from wall/other practical + specific reason

2

[10]

69. What happens when switch moved from A to B:

Ball released/drops

Clock starts

2

Time for ball to fall 1.00 m:

$$x = gt^2/2 \text{ [sufficient use of equation of motion]}$$

$$t^2 = 2 \times 1.00 \text{ m}/9.81 \text{ m s}^{-2} \text{ [correct substitution in all equations]}$$

$$t = 0.45 \text{ s}$$

3

Time for ball to reach ground, with reason:

0.45 s/same as before (e.c.f)

Horizontal and vertical motion independent/same (vertical) height

Same vertical distance/same (or zero) initial velocity

[NOT same force or acceleration]

2

Speed at which ball was fired:

$$2.00 \text{ m}/0.45 \text{ s (e.c.f)}$$

$$4.4 \text{ m s}^{-1}$$

2

[9]

70. In this experiment **alpha particles** were **scattered** by thin films of metals such as gold.

The experiment led to the conclusion that the atom had a **positively charged** nucleus of diameter approximately  $10^{-15} \text{ m}$  and containing

**most of the mass** of the atom

[5]

71. Half-life of radionuclide:  
 One value for half-life: 33 → 36 s  
 Repeat and average/evidence of two values (u.e.) 2
- Decay constant:  
 $\ln 2 \div \text{their value for } t_{1/2}$  calculated correctly  
 $= (0.02) \text{ s}^{-1}$  (u.e.) 1
- Rate of decay:  
 Tangent drawn at  $N = 3.0 \times 10^{20}$   
 Attempt to find gradient, ignore “-“ sign  
 $= 5.5 \rightarrow 6 \times 10^{18}$   
 [or Use of  $N = N_{0e}^{-\lambda t}$ , calculate  $\lambda$ , or other graphical means]
- [NB  $6.25 \times 10^{18} = 0/3$  as use of coordinates] 3
- Decay constant:  
 Substitute in  $dN/dt = -\lambda N$   
 e.g.  $6 \times 10^{18} = (-)\lambda \times 3 \times 10^{20}$  [their above]  
 $= (0.02)$  [their  $\lambda$  correctly calculated] 2
- Methods: 1  
 Either value chosen with a valid reason  
 e.g. 1<sup>st</sup> because can take several and average  
 1<sup>st</sup> because difficult to draw tangent

[9]

72. (a) (i) Reference to (individual) nuclei/atoms/particles  
 Each has a chance of decay/cannot predict which/when  
 will decay 2
- (ii) Use of  $\lambda t_{1/2} = \ln 2$   
 $\rightarrow \lambda = \ln 2 \div 600 \text{ s} = 1.16/1.2 \times 10^{-3} \text{ s}^{-1}$   
 $\therefore A = (1.16 \times 10^{-3} \text{ s}^{-1})(2.5 \times 10^5)$  [Ignore minus sign]  
 $= 288/290 \text{ Bq/s}^{-1}$  [c.a.o.] [Not Hz] [17 300  $\text{min}^{-1}$ ]
- (iii)  ${}^{13}_7\text{N} \rightarrow {}^0_1\text{e} / {}^0_1\beta + {}^{13}_6\text{C} / \text{X} (+ \nu_e)$  [N/O/C/X] [e.c.f.  $\beta^-$ ]  
 $[\beta^+$  on left, max 1/2] 5
- (b) (i) (Volume/level of)  $\text{CuSO}_4$  in burette =  ${}^{13}_7\text{N}$   
 Burette empties but N never reaches 0  
 (Volume of)  $\text{CuSO}_4$  in beaker =  ${}^{13}_6\text{C} / \text{X}$   
 Drops represent decay [accept represent  $\beta^+$ ]  
 (but) there is no randomness  
 and no particle given off  
 Exponential fall or rise in burette or beaker Max 3 marks

(ii) Use of  $R = \rho/lA$   
 $= (0.12 \Omega \text{ m})(0.050 \text{ m}) \div (0.02 \text{ m} \times 0.04 \text{ m})$  [Ignore units]  
 [Beware  $(0.04)^2$   
 $= 7.5 \Omega$  [e.c.f. 3.75  $\Omega$ ]  
 Add to 5.6  $\Omega$  [e.c.f.]  
 So  $I = V/R = 1.5 \text{ V} \div (5.6 \Omega + 7.5 \Omega)$  [e.c.f.]  
 $= 0.1145 \text{ A}/0.115 \text{ A}/0.114 \text{ A}/0.11 \text{ A}/0.1 \text{ A}$  [c.a.o.]

Assume: d.c. supply zero  $R$ / current perpendicular to plates.  
 E field perpendicular/ammeter  $R$  zero/no e.m.f. in beaker (e.g. bubbles) /  
 concentration electrolyte constant

[Not temperature constant]

6

[16]

73. The joule in base units:

$\text{kg m}^2 \text{ s}^{-2}$  [No dimensions] (1)

1

Homogeneity of formula:

$\rho$   $\text{kg m}^{-3}$  (1)

$r$   $\text{m}, f = \text{s}^{-1}$  (1)

(Right hand side units =  $(\text{kg m}^{-3}) (\text{m})^5 (\text{s}^{-1})^2$ ) [Correct algebra]

$= \text{kg m}^2 \text{ s}^{-2}$  [Only if 1<sup>st</sup> two marks are earned] (1)

3

[Ignore numbers; dimensions OK if *clear*]

Why formula might be incorrect:

The  $\frac{1}{2}$  could be wrong (1)

1

[5]

**74.** Demonstration of how statement leads to equation:

Momentum = mass × velocity (1)

Therefore force ∝ mass × rate of change of velocity (1)

Therefore force ∝ mass × acceleration (1)

Definition of newton or choice of units makes the proportionality constant equal 1 (1) 4

[Standard symbols, undefined, OK; “=” throughout only loses mark 4. No marks for just manipulating units. If no  $\Delta v$  (e.g.  $m v/t$ ), can only get marks 1 and 4]

Effect on time:

Time increases (1) 1

Explanation:

Acceleration smaller/momentum decreases more slowly/ $F = \frac{\Delta p}{\Delta t}$  (1)

[Need not say  $\Delta p = \text{constant}$ ]

So force is smaller (1) 2

[Independent mark, but must be consistent with previous argument]  
 [If *no* previous argument, this becomes fully independent mark] 7]

**75.** Calculation of work done:

Work = area under graph/average force × distance (1)

=  $\frac{1}{2} \times 0.040 \text{ m} \times 22 \text{ N}$  (1)

= 0.44 J (1) 3

[Allow any correct unit, e.g. N m. Penalise unit once only]  
 [ $Fd \rightarrow + 0.88 \text{ J}$  gets 1/3]

Calculation of energy:

GPE =  $0.024 \text{ kg} \times 9.81 \text{ (or } 10) \text{ m s}^{-2} \times 0.60 \text{ m}$  (1)

= 0.14 J (1) 2

Comparison:

Some energy transferred to some other form (1)

Reason [a mechanism or an alternative destination for the energy], e.g. (1)

- Friction
- Air resistance
- Heat transfer to named place [air, frog, surroundings etc]
- Internal energy
- Vibrational energy of spring
- Sound

OR quantitative comparison (0.3 J converted)

[No e.c.f. if gpe > work] 2

[7]

**76.** Explanation:

Changing direction/with no force goes straight on (along tangent) (1)  
 Acceleration/velocity change/momentum change (1) 2

Identification of bodies:

A: Earth [*Not* Earth's gravitational field] (1)

B: scales [*Not* Earth/ground] (1) 2

Calculation of angular speed:

Angular speed = correct angle ÷ correct time [any correct units] (1)

=  $4.4 \times 10^{-3} \text{ rad min}^{-1} / 0.26 \text{ rad h}^{-1} / 2\pi \text{ rad day}^{-1}$  etc (1) 2

Calculation of resultant force:

Force =  $mr\omega^2$  (1)  
 =  $55 \text{ kg} \times 6400 \times 10^3 \text{ m} \times (7.3 \times 10^{-5} \text{ rad s}^{-1})^2$  (1)  
 = 1.9 N (1) 3

[No e.c.f here unless  $\omega$  in  $\text{rad s}^{-1}$ ]

Calculation of value of force B:

Force B =  $539 \text{ N} - 1.9 \text{ N}$  (1)  
 = 537 N (1) 2

[e.c.f. except where R.F = 0]

Force:

Scales read 537 N (same as B) [allow e.c.f.]

Newton's 3rd law/force student exerts on scales (1) 1

**[12]**

77. Completion of nuclear equations:

${}_{92}^{238}\text{U}/{}_{92}^{238}\text{U}$  (1)

${}_{2}^{4}\alpha / {}_{2}^{4}\text{He}$  (1)

${}_{91}^{234}\text{X}$  [*Not* Th] (1)

${}_{-1}^{0}e / {}_{-1}^{0}\beta$  [*Not*  $-1e$ ] (1) 4



Use of magnetic field to distinguish alpha particles:

B field perpendicular to direction of motion of particles *or*

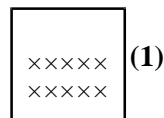

Particles deflected in opposite directions (1)

$\beta$  curve more than  $\alpha$  /  $\alpha$  harder to deflect /  $\beta$  affected more (1)

[Magnets marked +/-, 0/2]

$\alpha$   $\beta$  attracted / repelled by N/S, 0/2]

Max 2

[6]

78. Verification and other measurement:

Measurement of mass e.g. (top pan) balance (1)

Measurement of volume e.g. measuring cylinder/rectangular container (1)

Gradient/use of density = mass  $\div$  volume with mass corrected for container

Repeat reading/plot  $m$  v v/conversion of g to kg *or*  $\text{cm}^3$  to  $\text{m}^3$  (1)

[If states will use  $1 \text{ m}^3$  of water, then 0/3]

max 3

Temperature (1)

1

Explanation:

Atoms/molecular separation in gases is much greater (than in both solids and liquids) (1)

This means fewer atoms or less mass in the same volume

OR

This means a larger volume to contain same number of atoms

OR the same mass. (1)

2

[6]

79. Addition of forces to produce a free-body diagram for trolley:

[Unlabelled arrows = 0; ignore point of application of force] (1)

R/N/Reaction/push of slope/ normal contact force

[NOT normal]

should be approximately perpendicular to slope]

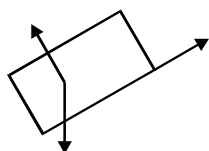

F/friction/drag/air resistance (1)

3

W/weight/mg/pull of Earth/gravitational force

[Not gravity] [Should be vertical by eye]

Evidence that trolley is moving with constant velocity: 1  
 Trolley travelled equal distances (in same time)  
 Acceleration of trolley down slope: 1  
 0 / no acceleration  
 What value of acceleration indicates about forces acting on trolley: 1  
 Forces balance OR  $\Sigma F = 0$  OR in equilibrium OR zero resultant  
 [Forces are equal 0/1]

[6]

80. Calculation of how long wheel takes to complete one revolution:

Time =  $2\pi \times 60 \text{ m} / 0.20 \text{ m s}^{-1}$  (1)  
 = 1900 s / 1884 s / 31.4 min (1) 2

Change in passenger's velocity:

Direction changes OR up (N)  $\rightarrow$  down (S) OR +  $\rightarrow$  - (1)  
 OR 180° (1) 2  
 0.40 m s<sup>-1</sup>  
 [0.40 m s<sup>-1</sup> without direction = 2/2]

Calculation of mass:

(G)pe =  $mgh$   
 $m = 80 \times 10^3 \text{ J} / 9.81 \text{ m s}^{-2} \times 120 \text{ m}$  (1)  
 [This mark is for rearranging the formula; accept 10 instead (1)  
 of 9.81 and 60 instead of 120 but do not e.c.f. to next mark]  
 $m = 68 \text{ kg}$  (1) 3

Sketch graph:

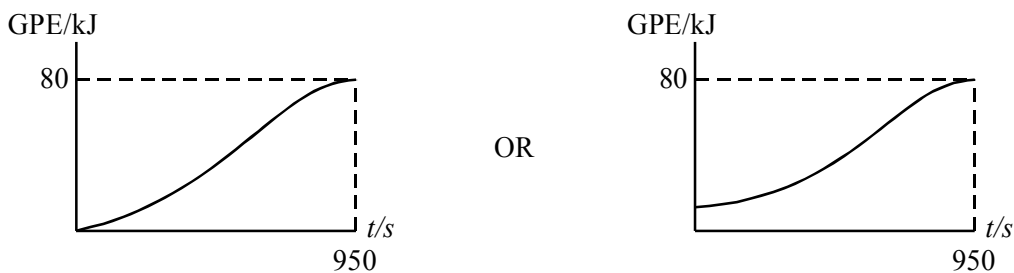

Labelled axes and line showing PE increasing with time  
 Sinusoidal shape (1)  
 (950 s, 80 kJ) (1)  
 [Accept half the time they calculated at start of question (1)  
 instead of 950 s as e.c.f.]  
 [PE v h 0/3] 3

Whether it is necessary for motor to supply the gpe:

No, because passenger on other side is losing gpe (1)  
If wheel equally loaded OR balanced with people (1)

OR

Yes, because no other passengers (1)  
so unequally loaded (1)

2

[12]

81. Definition of linear momentum:

Mass  $\times$  velocity [Words or defined symbols; NOT *ft*] (1)

1

Newton's second law:

Line 3 only (1)

1

Newton's third law:

Line 2 OR 1 & 2 (1)

1

Assumption:

No (net) external forces/no friction/drag (1)

In line 3 (he assumes the force exerted by the other trolley is  
the resultant force) [Only if 1<sup>st</sup> mark earned] (1)

2

Description of how it could be checked experimentally that momentum is conserved in a  
collision between two vehicles:

Suitable collision described and specific equipment to  
measure velocities [e.g. light gates] (1)

Measure velocities before and after collision (1)

How velocities calculated [e.g. how light gates used] (1)

Measure masses / use known masses/equal masses (1)

Calculate initial and final moment a and compare OR  
for equal trolleys in inelastic collision, then  $v_1 = \frac{1}{2} v_2$  (1)

Max 4

[9]

82. Number of protons and neutrons:

Number of protons = 6 (1)

Number of neutrons = 8 (1)

2

Demonstration of volume of a carbon-14 nucleus:

Use of cube or sphere (1)

Volume =  $8.2 \times 10^{-44} \text{ m}^3$  (1)

2

[2<sup>nd</sup> mark only for a sphere calculation]

Determination of density of nucleus:

Correct use of density =  $m/V$  (1)

Density =  $2.8 - 2.9 \times 10^{17} \text{ kg/m}^3$  [To 2 sig. figs] (1)

2

[No e.c.f from wrong volume]

How value compares with densities of everyday materials:

Massive/much higher (1)	
[E.c.f. from their value]	1
Meaning of term half-life:	
Average (1)	
Time taken for the activity/mass/no. of nuclei/no. of atoms/ count rate to drop by half OR time for half the sample to decay (1)	2
Calculation of decay constant of carbon-14 in $s^{-1}$	
$\lambda = 0.69 / (5700)$ [Rearrange and insert half-life in any unit] (1)	
$\lambda = 3.8 \times 10^{-12}$ [no e.c.f for wrong half-life] (1)	2

[11]

83. Completion of diagram:

Newton balance /scales [somewhere in diagram] (1)	
Supports at each end [i.e. newton balance/scales] (1) [within 5 mm of the ends] [Allow non-vertical spring balances]	2

Principle of moments:

<u>Total</u> (sum of) clockwise moment = <u>total</u> (sum of) anticlockwise moment about the same point (1)	
for a body in equilibrium (1)	2

Use of principle to explain why  $Q$  increases as  $d$  increases:

Moment of $V$ [OR clockwise moment] increases (1)	
$Q$ must increase for its moment [OR the anticlockwise moment] to balance this (1)	2

Calculation of  $W$  using information from graph:

Use the point $d = 0$ (1)	
$WN \times 0.5 \text{ m} = 0.45 \text{ N} \times 1 \text{ m}$ (1)	
$W = 0.90 \text{ N}$ (1)	
Other methods:	
Get necessary information from graph (1)	
Correct equations (1)	
0.90 N (1)	3

[9]

84. How to determine background radiation level in laboratory:

Source not present/source well away from GM tube [ $> 1 \text{ m}$ ] (1)	
Determine - count over a specific period of time $> 1 \text{ min}$ OR repeats (1)	2

How student could confirm that sample was a pure beta emitter:

To demonstrate no  $\gamma$ :

Al between tube and source: reading  $\rightarrow$  0 or background (1)

No  $\gamma$  /  $\gamma$  not stopped by Al (1)

To demonstrate no  $\alpha$ :

GM moved from very close (or  $\approx$  1 cm) to source  
to  $\approx$  10 cm: count rate does not drop (or no sudden drop) (1)

No  $\alpha$  /  $\alpha$  stopped by a few cm air (1)

Clarity: Only available if at least 2 of above 4 marks  
awarded. Use of bullet points acceptable. (1)

5

[7]

85. Completion of table:

	Alpha particle scattering	Deep inelastic scattering
Incident particles	Alpha particles	<i>Electrons/ neutrinos/leptons</i>
Target	<i>Gold foil/ gold atoms/gold nuclei</i>	Nucleons

Gold foil / gold atoms / gold nuclei (1)

Electrons/neutrinos/leptons [NOT  $\beta$ ] (1)

2

Description of conclusion from each experiment:

Alpha particle scattering

Atom is mainly space/contains small nucleus

Contains a dense/massive nucleus [NOT small]

[Ignore “+ charge”]

Deep inelastic scattering:

Nucleons/protons/neutrons have a substructure/are not  
fundamental particles/can be split up (1)

of quarks [only if previous mark awarded] (1)

[e.g. “the nucleus is made of quarks” gets 2]

4

[6]

86. Calculation of resultant force:

$$[a = (v - u)/t = 16 \text{ m s}^{-1} / (4 \times 60) \text{ s}]$$

$$= 0.0666 \text{ m s}^{-2}$$

$$F = ma = 84\,000 \text{ kg} \times 0.0666 \text{ m s}^{-2} = 5600 \text{ N}]$$

OR

Use of $\frac{(v - u)}{t}$	use of $m v$	(1)	
Use of $F = ma$	use of $\frac{m v}{t}$	(1)	
5600 N	5600 N	(1)	3

Free-body force diagram:

Diagram [truck can be just a blob] showing:

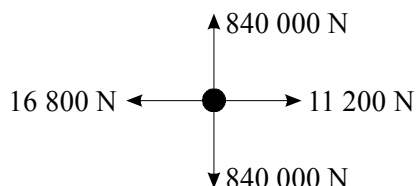

823 200 – 840 000 N down	(1)
same as down      up	(1)
11 200 N      either way	(1)
correct resultant      to left	
[e.c.f.]	

4

[Ignore friction. Each extra force –1]

Calculation of average power:

Power = KE gained/time = $\frac{1}{2}mv^2/t$	OR	KE = $3.84 \times 10^8$ J	(1)
= $3.84 \times 10^8$ J/(4 × 60) s			(1)
= $1.60 \times 10^6$ W [OR J s <sup>-1</sup> ]			(1)

3

Other credit-worthy responses:

$\frac{1}{2} m v^2$	Fv	$\frac{F d}{t}$	(1)
$\frac{1}{2} \times \frac{3 \times 10^6 \times 16^2}{240}$	$3 \times 10^6 \times 0.666 \times 8$	$\frac{3 \times 10^6 \times 0.666 \times 1920}{240}$	(1)
		[e.c.f. 0.666 and 1920 possible]	
$1.6 \times 10^6$ W	$1.6 \times 10^6$ W	$1.6 \times 10^6$ W	(1)

3

Calculation of average current:

$P = IV = I \times 25\,000 \text{ V} = 1.60 \times 10^6 \text{ W}$	Use of $P = IV$	2
--	-----------------	---

[12]

87. Correct quantities on diagram:

Upper ellipse	capacitance	[ <b>not</b> energy]	[Accept capacitance <sup>-1</sup> ]	(1)
Lower ellipse	resistance	[ <b>not</b> power]	[Accept conductance/resistance <sup>-1</sup> ]	(1)
				2

Explanation:

Base quantities/units	[ <b>Not</b> fundamental]	(1)
Not derived from other (physical) quantities		(1)
OR other (physical) quantities are derived from them		
OR cannot be split up/broken down		
		2

[4]

88. Show that force  $R = 24\,300\text{ N}$

Force  $R =$  weight of wall B +  $\frac{1}{2}$  weight of floor C

OR  $R = 2300\text{ N} + (\frac{1}{2} \times 44\,000\text{ N})$  [No unit penalty here] (1)

Addition of force onto the diagram:

Weight arrow added to joist A

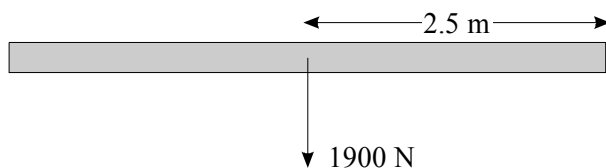

1

[Ignore missing units; penalise wrong units] (1)

Labelled 1900 N **and** acting downwards (1)

Labelled as being central 2

Calculation:

Any use of moments.... "A force  $\times$  a distance" (1)

$P = 6300\text{ N} - 6400\text{ N}$  (1)

$Q = 32\,000\text{ N} - 33\,000\text{ N}$  (1)

3

[6]

89. Principle of conservation of linear momentum:
- [Not just equation – symbols must be defined]
  - Sum of momenta/*total* momentum remains constant (1)
  - [Equation can indicate]
  - [Not “conserved”]
  - If no (resultant) external force acts (1)
  - [**Not** “closed/isolated system”] 2
- Laws of Motion:
- 2<sup>nd</sup> and 3<sup>rd</sup> laws (1)
  - 1
- Description:
- Measure velocities/speeds before and after collision (1)
  - Suitable technique for measuring velocity
  - e.g. ticker tape/ticker timer
  - light gate(s)
  - motion sensor (1)
  - [Not stop clock or just datalogger]
  - How velocity is found from **their** technique
  - [Need distance ÷ time + identify distance and time. Could get with stopclock method.] (1)
  - (1)
  - $v_{\text{after}} = \frac{1}{2} v_{\text{before}}$  / calculate  $m v$  before and after/check e.g.  $m_1 v_1 = (m_1 + m_2) v_2$  4
- Reason for discrepancy:
- Friction/air resistance (1)
  - [Ignore any reference to energy] (1)
- Explanation:
- The Earth (plus car) recoils (1)
  - With same momentum as the car had (1)
  - 2

[10]

90. Description of motion:
- AB: uniform acceleration OR *v* increases at constant rate (1)
  - [**Not** accelerates constantly]
  - BC: sudden deceleration OR slows down/stops rapidly (1)
  - 2



Explanation of cause of motion:

AB: Attraction to positive/power supply/the voltage/energy of supply/(electric) force from supply OR electric field (in wire) (1)

BC: collision with ion/atom/electron/nucleus/lattice (1)  
2

Explanation of term *drift velocity*:

Drift velocity: average mean/net/overall velocity of electron along wire (1)  
[Not speed]

Value shown on graph (allow between 1/3 and 2/3 of maximum velocity) (1)  
[Line or mark on graph axis, label not needed if only one line/mark] 2

Explanation of why wire gets warm:

Collision makes ion/atom vibrate more vigorously  
OR in collision energy is transferred to lattice (1)  
1

[7]

91. Nuclear equation:

${}_{15}^{32}\text{P} \rightarrow {}_{16}^{32}\text{S} + \beta^{-} \left| \begin{smallmatrix} 0 & \beta \\ -1 & \beta \end{smallmatrix} \right| e^{-} \quad [\text{Ignore } + \gamma + \nu]$  (1)  
1

Description:

Take background count (1)

Take count close to source, then insert paper/card and count (1)

Little/no change (1)

[OR absorption in air: Take close reading and move counter back; no sudden reduction (1)(1)]

Insert sheet aluminium and count (1)

Down to background, or zero (1)

Max 4

Diagram: Any region above dots [show (1) or (X)]

(1)  
1

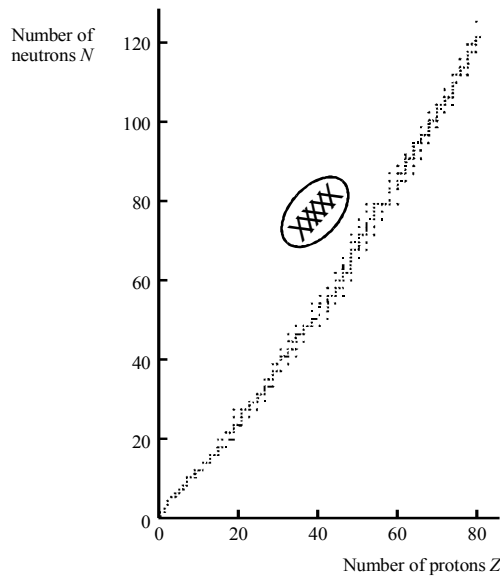

Explanation:

1.  $\beta^-$  decay involves a neutron  $\rightarrow$  a proton Any two from: (1)  
Any two from:
2. on the diagram this means  $\downarrow^{-1}$  ( $+1$  / diagonal movement
3. so nuclide moves towards dotted line
4. decay means greater stability (1)(1)  
[ $\beta^-$  in wrong region, (1) and (4) only available.  
Decay towards drawn  $N=Z$  line 1 and 2 only available]

[9]

92. Momentum of driver:

Correct use of  $p = mv$  [OR with numbers] (1)

= 1500 N s OR 1500 kg m s<sup>-1</sup> (1) 2

Average resultant force:

Correct choice of  $F \times t = \Delta p$  OR  $F = ma$  (1)

$F \times 0.07$  (s) = 1500 (N s)  $F = 50 \times 429/50 \times 30/0.07$  (1)

= 21 kN = 21 kN (1) 3

[Ignore sign of answer]

Why resultant force is not the same as force exerted on driver by seatbelt:

Air bags /floor/friction/seat/steering wheel (1)

[Named force other than weight/reaction] 1

[6]

93. Why alpha particles only travel a short distance:  
 Strongly /highly likely to collide OR lost energy rapidly (1)  
 Description of the process/ionising (1) 2

Significance of radioactive half-life for health of the worker – any two:  
 (Average) time for half nuclei/atoms (not particles or mass) to decay OR (1)  
 activity to halve  
 If short (most decay before excretion) so large dose (1)  
 consequent damage (1)  
 OR  
 If long (few decay before excretion) so small dose (1)  
 consequent damage (1) Max 2  
 [Do not accept argument in terms of what would happen if material not excreted]

[4]

94. Completion of table:

Force	Description of force	Body which exerts force	Body the force acts on
<i>A</i>	Gravitational	Earth	Child
<i>B</i>	<i>(Normal) reaction OR contact OR E/M (1)</i>	<i>Earth/ground (1) for both</i>	<i>Child</i>
<i>C</i>	<i>Gravitational [Not gravitational weight] (1)</i>	<i>Child (1) for both</i>	<i>Earth</i>

4

Why *A* and *B* are equal in magnitude:

Child is at rest/equilibrium OR otherwise child would move/accelerate (1)  
 [NB use of N3 would contradict this]

Why must forces *B* and *D* be equal in magnitude:

Newton's third law OR action + reaction equal and opposite (1)  
 [NB use of N1 or N2 here would contradict this] [Not Newton pair] 2

What child must do to jump and why he moves upwards:

Push down, increasing *D* (1)  
 $\therefore$  *B* increases [must be clearly *B* or description of *B*] (1)  
 and is  $> A$  OR there is a resultant upward force [clearly on child] (1)  
 [Not "movement"] 3

[9]

95. Force:

200 N (1)

1

Free body force diagram:

[Unlabelled arrows = 0; ignore point of application of force]

[Double arrows = 0] [Arrows required for marks]

$W$  / weight / 400 N /  $mg$  / pull of Earth / gravitational force (1)

[Not gravity]

Two tensions OR Two  $\times$  300 N OR two  $\times$  311 N (1)

[Accept  $T$  for tension OR any label that is not clearly wrong,

e.g. R/W/N 200 N]

2

Applied force:

Attempt to resolve vertically (1)

$2T \sin 40 = 400$  (1)

[ $400 \times \cos 40 \rightarrow 306$  N (no marks)

$400 \times \sin 40 \rightarrow 257$  N (no marks)

$200/\cos 40^\circ = 261$  N  $\rightarrow$  gets 1 out of 3 (attempted to resolve)]

$T = 310$  (N) OR 311 (N) [No unit penalty] (1)

3

Two reasons why first method is easier:

Force applied is smaller/feels lighter/tension smaller [Not weighs less] (1)

They are not pulled sideways/forces only upwards/pulling against each other (1)

[Answer must be in terms of forces]

2

Why solution is not sensible:

Because the tension (or description of tension) would be greater (1)

OR bigger sideways force

1

[Do not accept bigger force]

[9]

96. Completion of diagram:

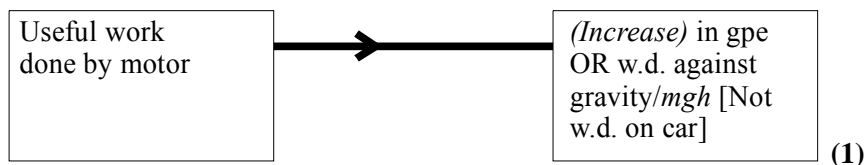

1

(i) Useful work done by motor:

Correct substitution in  $mgh$ , i.e.  $3400$  (kg)  $9.81$  ( $\text{m s}^{-2}$ )  $\times$   $30$  (m) (1)

$= 1.00$  MJ OR  $\text{M Nm}$  [ $1.02$  MJ] (1)

(ii) Power output of motor:

Power = above (J) /  $15$  (s) (1)

$= 67$  kW [e.c.f.] (1)

4

Overall energy conversion occurring as vehicle travels from B to C:

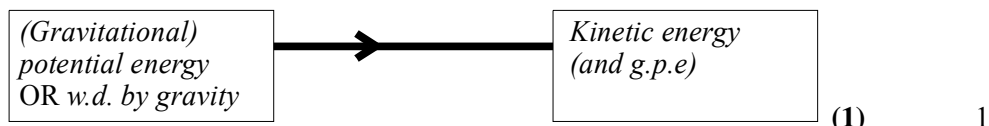

Speed of vehicle at point C:

$$\Delta h = 18/(30 - 12) \text{ (1)}$$

$$\text{Use of } \frac{1}{2} mv^2 = \text{g.p.e. lost (1)}$$

[If get height wrong, can only get second mark]

$$v = 19 \text{ m s}^{-1} [18.8 \text{ m s}^{-1}] \quad 3$$

How speed at C would be expected to differ from previous answer:

Same speed/no effect [If this is wrong, no marks] (1)

GPE and KE both symbol  $\frac{1}{2} mv^2$  OR  $g$  same for all masses OR  $ms$  cancel (1) 2

[Not  $g$  is constant]

[11]

97. Temperature at which density is a maximum:

$$4.0 - 4.2^\circ\text{C} \text{ [NB Unit error] (1)} \quad 1$$

Sketch graph:

Opposite shape (1)

Mirror image  $\rightarrow$  Max density at about  $4^\circ\text{C}$  (1)

Attempt to use  $D = m/V$  (1) Max 3

How to demonstrate that volume of water behaves in manner indicated:

Method of measuring volume, e.g. measuring cylinder/syringe/test tube (1)  
[not beaker]

Method of heating, e.g. water bath from approx.  $0^\circ\text{C}$  – about  $10^\circ\text{C}$  (1)  
[no bunsen burners] OR freezing + allowing to warm up in air

Magnification of small volume change (1)

Clarity mark in context: Context = measuring  $D$  or  $V$  of liquid (1) Max 3

[7]

98. Sources of background radiation:

Radioactive rocks/radon gas/cosmic rays or solar wind (1)

Fall out/leaks from nuclear installations  
named materials, e.g. uranium/granite/ $^{14}\text{C}$  (1) 2

Nuclear equation:

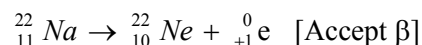

22 and 0 (1)

10 and +1 OR 10 and 1 (1)

20 – 26 Na [NOT  $^{22}\text{Na}$ ] [Must have correct proton number, if given] (1) 3

Decay constant of sodium-22 in  $s^{-1}$ :

$$\lambda = 0.69/2.6 \text{ [Ignore conversion to seconds] [Not } 0.69/1.3 \text{] (1)}$$

$$\lambda = 8.4 \times 10^{-9} \text{ [No unit, no e.c.f.] (1)}$$

Number of nuclei:

$$2.5 = 8.4 \times 10^{-9} N \text{ (1)}$$

$$N = 3.0 \times 10^8 \text{ (1)}$$

4

Whether salt is heavily contaminated:

(No.) This is a small number (compared to no. of atoms in a spoonful of salt)

OR

Rate < background (1)

1

[10]

99. Uranium correctly marked at (92, 142) (1)

Beta decay: SE at  $45^\circ$  [One box] into the uranium (1)

Alpha decay: Proton number down 2 (1)

Neutron number down 2 (1)

[NB No arrows needed, but lines must be labelled appropriately; lines not essential if clear]

[4]

100.  $t = 2.1s$

1

Represents acceleration of the ball

Force on ball *or* gravitational field strength  
*or* acceleration is constant *or* uniform

2

Relevant equation *or* correct area

Substitution correct

2

Displacement /m

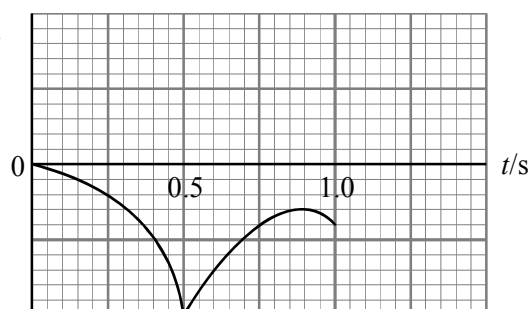

Displacement scale as shown above

First half of curve correct

Second half correct with reduced height

3

-1.25 m (correct magnitude *and* direction)

[Look at candidate's displacement origin]

1

[9]

101. Gain in g.p.e. =  $(55.0 \text{ kg}) \times (9.81 \text{ N kg}^{-1}) \times (3.60 \text{ m})$   
 = 1940 J  
 Power = gain in g.p.e./time  
 Power = 1080 W 4  
 Units correctly attached to a correct equation  
 e.g.  $\frac{\text{Power}}{\text{Weight}} = \frac{\text{Nms}^{-1}}{\text{N}}$   
 =  $\text{ms}^{-1}$  2  
 Power to weight ratio =  $\frac{1080 \text{ W}}{(55.0\text{kg}) \times (9.81\text{ms}^{-2})}$   
 (allow e.c.f. for power)  
 Power to weight ratio = 2 [ $\text{ms}^{-1}$ ] 2
- [8]**
102.  $30 \text{ m} \div (5 \times 0.62 \text{ s})$   
 =  $9.7 \text{ m s}^{-1}$  2  
 $(7000 \text{ kg} \times 9.7 \text{ m s}^{-1})$  [allow  $10 \text{ m s}^{-1}$  as e.c.f.]  
 = 68 000 ( $\text{kg m s}^{-1}$ ) 2  
 Momentum before = momentum after  
 $(7000 \text{ kg} \times 9.7 \text{ m s}^{-1}) + 0 = (7000 \text{ kg} + 5000 \text{ kg}) \times v$   
 $v = (7000 \text{ kg} \times 9.7 \text{ m s}^{-1}) \div (12 000 \text{ kg})$   
 =  $5.7 \text{ m s}^{-1}$  [allow 5.8 if e.c.f. of  $10 \text{ m s}^{-1}$ ] 3  
 Force = change in momentum  $\div$  time  
 =  $7000 \text{ kg} \times [9.7 \text{ m s}^{-1} - 5.7 \text{ m s}^{-1}] \div 0.30 \text{ s}$   
 = 93 000 N [98 000 N if  $10 \text{ m s}^{-1}$  used] 3
- [10]**
103. Average force  
 multiplied by distance moved in direction of force 2  
 Work done negative when force is in opposite direction to displacement  
 Kinetic energy is reduced/gets less 2  
 Free body diagram:  
 Weight vertically downwards (1)  
 Produced by gravitational pull of Earth (1)  
 F (resistive force/drag) parallel to slope and upwards (1)  
 Produced by (friction with) snow/air (1) Max 3  
 Resultant force: zero  
 Work done by N: zero 2
- [9]**
104. For a body in an equilibrium state  
 the sum of the clockwise moments equals the sum of the  
 anticlockwise moments (about the same point) 2  
 Force at A:

$$F_A \times (80 \text{ m}) = (120 \text{ kN}) \times (50 \text{ m})$$

$$= 75 \text{ kN}$$

Force at B:

$$F_B = (120 \text{ kN}) - F_A$$

$$= 45 \text{ kN}$$

4

[Accept calculation of B leading to calculation of A ]

[6]

105. Two sources of different origin, e.g. cosmic radiation, rocks

2

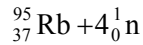

i.e.  ${}_{4}^{37}$

2

$6.4 \times 10^{15}$  atoms/nuclei of Cs decay  
on average each second

2

Either:

$$6.4 \times 10^{15} \div 2.5 \times 10^{13} = 256$$

$$= 2^8 \text{ i.e. } 8 \text{ half-lives}$$

Or

$6.4 \times 10^{15} \div 2$  successively  
until, after 8 times, gives  $2.5 \times 10^{13}$

2

Two problems which are relevant to the very long storage time involved  
e.g. deterioration of container; finding a site which will remain safe;  
long term monitoring

2

[10]

106. Most  $\alpha$  particles pass }  
Some flashes are seen } *straight through (or equivalent)*  
Some are deflected slightly  
Some rebound (or equivalent)

3

(Deflection) links positive  $\alpha$ -particles and positive nucleus  
Link large proportion straight through and small proportion strongly deviated  
with mainly space and small nucleus

3

Diameter of gold atom:  $10^{-9}\text{m}$   
Diameter of a gold nucleus:  $10^{-15}\text{m}$

2

[8]

107. Density (1)

Displacement [not distance] (1)

Acceleration due to gravity/gravitational field  
strength/acceleration of free fall/acceleration g  
[not gravity or gravitational force/pull] [not g]  
[not acceleration by itself] (1)

Number of nuclei/atoms [not particles, molecules]  
[not amount of substance] [not nuclides, decayed nuclei] (1)

[4]

108. Diagram:



Shown and labelled

Ticker timer at top **or** Strobe light (1)  
Tape from trolley through timer **or** camera [consequent] (1)

OR

Motion sensor pointing at trolley **or** video (1)  
Connection to datalogger/computer **or** rule [both consequent] (1)

OR

**Three** or more light gates (1)  
Connection to datalogger/computer [consequent] (1)

[**Two** light gates connected to 'timer' – max 1]

[Rule **and** stop clock - max 1]

Values for  $v$  and  $a$ :

2

**0.95** m s<sup>-1</sup> [2 s.f.] (1)

Use of gradient or formula (1)

**0.79** m s<sup>-2</sup> [no e.c.f. if  $u = 0$ ] (1)

Distance AB:

3

AB = 'area' under graph, or quote appropriate equation of motion (1)

Physically correct substitutions (1)

**0.86** m [allow **0.9** m] [e.c.f. wrong  $u$  or  $a$ ] (1)

Graph:

3

Smooth curve rising from origin, getting steeper (1)

Initial gradient non-zero [consequent] (1)

(**0.70**, **0.86**) matched (e.c.f. on distance) (1)

3

[11]

**109.** Engine (or plane) pushes/forces the gases (1)

Gases push forwards/opposite direction on engine (or plane) (1)

**Relating** this to Newton's third law (1)

Force accelerates plane/increases its momentum, **by** Newton's second law/

$F = ma$  (1)

Max 3

Clarity of answer (1)

1

[4]

**110.** Resultant moment:

Use of moment = force  $\times$  distance (1)

**1.2** N m (1)

Resultant force:

$$\begin{aligned} \text{Resultant force} &= \frac{\sqrt{(5.0 \text{ N})^2 + (5.0 \text{ N})^2}}{2 \times 5.0 \text{ N} \times \cos 45} & (1) \\ &= 7(.1) \text{ N} \text{ [not } \sqrt{50}] & (1) \\ &\quad \text{at } 45^\circ \text{ [can be on diagram]} & (1) \\ &\quad \text{approx. N.E. [can be on diagram]} & (1) \end{aligned}$$

Diagram:

Any arrow vertically downwards [2 arrows 0/2] [ignore values] (1)  
 Any line through O (1)

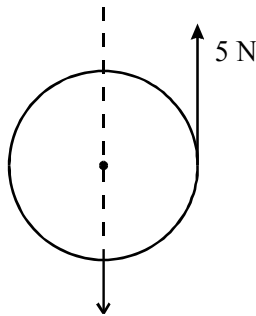

[8]

111. [Accept use of 0.5 s or 0.6 s intervals in calculations. Values using 0.6 s are shown in square brackets.] (1) 2

Speed:

Use of distance/time (1)

$$6.4 \text{ m s}^{-1} \quad [5.3 \text{ m s}^{-1}]$$

Conservation of momentum:

$$\text{Final } v_A = 4.4 \text{ m s}^{-1} (2.2/0.5) [3.7 (2.2/0.6)] \quad (1)$$

$$\text{OR } v_B = 8.4 \text{ m s}^{-1} (4.2/0.5) [7.0 (4.2/0.6)] \quad (1)$$

Any use of  $p = mv$

$$\text{Use of } p_i = (\Sigma m) u_i \quad (1)$$

$$\text{Use of } p_f = (\Sigma m v_f) \quad (1)$$

$$p_i = 832 \text{ N s/kg m s}^{-1} [689], p_f = 792 \text{ N s/kg m s}^{-1} [662.5] \quad (1)$$

(both  $\pm 5$ ) [consequent on all 4 above] 5

Reason:

On ice friction is small / No external forces/friction (1) 1

Explanation:

Total kinetic energy increases (1)

Skater does work pushing partner away [conditional] (1) 2

[10]

Explanation:

- 1  $\beta^-$  decay involves a neutron  $\rightarrow$  a proton Any two from: (1)  
Any two from:
2. on the diagram this means  $\downarrow^{-1}$  ( $+1$  / diagonal movement
3. so nuclide moves towards dotted line
4. decay means greater stability (1)(1)

$[\beta^-$  in wrong region, (1) and (4) only available.

Decay towards drawn  $N = Z$  line 1 and 2 only available]

[9]

**112.** Calculation of g.p.e:

Use of  $m = \rho V$  (1)

Use of  $E_p = mgh$  [ $m = 8.1 \times 10^x$  kg] (1)

64 J (1) 3

Explanation:

(Some) water has moved up (1) 1

Why g.p.e. is less:

Water has less mass (1)

Water has lower density/ moved up same distance/where the block was. (1)

OR

Some energy is dissipated/lost to surroundings/converted to other forms (1)

K.E./internal energy/heat/sound (1)

OR

Mechanism: via friction or drag/because the block or water accelerates/as block hits the bottom (2) 2

[6]

**113.** Compositions of nuclei:

Different number of neutrons (1)

Same number of protons / proton no. (1)

Physical property:

Boiling point/melting point/density/ [ not mass; heavier; RAM] (1) 3

Nuclear Equation:

$\left(\begin{smallmatrix} 3 \\ 1 \end{smallmatrix}\right)\text{H}$  (1)

$\left(\begin{smallmatrix} 3 \\ 2 \end{smallmatrix}\right)\text{He}$  (1)

$\left(\begin{smallmatrix} 0 \\ -1 \end{smallmatrix}\right)\beta$  (1) 3

Experiment:

GM tube [allow ionisation chamber, cloud chamber] (1)

How to check no alpha:

Source close/next to/near/up to 5 cm to GM or ionisation /cloud chamber, insert paper, no change in 'count rate'

OR

Source close to GM, move away, no sudden drop in count rate (1)

How to check no gamma:

Insert a few mm aluminium, count rate reduced to zero

OR

Apply E or B field, GM tube fixed, count rate to zero (1)

Correcting/Allowing for background (i.e. measure it, and look for count reducing to background in "no gamma" test) (1)

4

[10]

**114. Half-life:**

Use of  $t_{1/2} \quad \lambda = 0.69$  (1)

13 (1)

Initial number of nuclei:

Use of  $A = \lambda N$  (ignore wrong time units) (1)

$1.0 \times 10^{15}$  (1)

4

Graph:

Horizontal line from same initial point (1)

[max drop 1 small square]

Initial activity marked as  $6.4 \times 10^8$  Bq or equivalent scale (1)

Their half-life marked where  $A = 3.2 \times 10^8$  Bq, or equivalent scale (1)

3

[7]

**115. Graphs:**

Variable on y axis	Variable on x axis	Graph
Activity of a radioactive source	Time	C
Increase in gravitational potential energy of a body	Vertical height body is raised	A
Acceleration produced by a constant force	Mass of body being accelerated	B
Half-life of a radioactive source	Number of nuclei present in the source	E

4

[4]

- 116.** Composition of alpha, particle  
 2 protons + 2 neutrons **only** (1) 1
- Explanation of ionise  
 Change number/Add/Remove **electrons** (1) 1
- Estimation of time alpha particle would take to travel  
 Use of  $E_k = mv^2/2$  (1)  
 Use of  $t = \text{diameter}/v$  (1)  
 $6.3 \times 10^{-18}$  s [no ecf] (1) 3
- Explanation comparing speed of alpha and beta particles  
 Faster (1)  
 Less massive/lighter/less weight (1) 2
- Reason why beta particles less effective  
 Beta spends less time in the atom/goes through atom more quickly/less charge (1) 1

[8]

- 117.** Explanation of essential difference between 2 definitions  
 Distance in direction of force against distance perpendicular to force (1)  
 Correctly identifying which is which (1) 2
- Principle of moments  
 $AP = 80$  mm,  $PB = 32$  mm [allow  $\pm 1$  mm] [no ue] (1)  
 Demonstrate that moments are equal. [allow any distance values] (1) 2
- Distance load at B raised  
 Use of work = force  $\times$  distance use of  $mgh$  [beware  $m = 20$ ] (1)  
 Use of work out = work in / use of  $mgh$  lost  $mgh$  gained (1)  
 $2.4 \times 10^{-3}$  m (1)
- OR
- Similar triangles/distance moved  $\propto$  distance from pivot (1)  
 $x/6 \times 10^{-3} = 32/80$  or equivalent (1)  
 $2.4 \times 10^{-3}$  m (1) 3

[7]

- 118.** Deceleration of cars  
 Acceleration = gradient / suitable eqn. of motion. (1)  
 Correct substitutions [ 0.9 for t is wrong] (1)  
 $6.1 - 6.3$  m s<sup>-2</sup> [-ve value -1] [no ecf] (1) 3
- Area under velocity-time graph  
 Distance/displacement (1) 1
- Shaded area  
 $6.9 - 7.5$  (1)  
 m (1) 2
- [Allow 1 mark for  $5.5 - 6.1$  cm<sup>2</sup>.]
- Minimum value of the initial separation  
 Same as above [ecf] (1)  
 Area is the extra distance car B travels/how much closer they get (1) 2

Graph

Both sloping lines continued down to time axis [by eye] (1) 1

Explanation

Area between graphs is larger/B travels faster for longer/B still moving when A stops (1)

Extra distance B goes is larger/ > '7.2' (1)

Initial separation must be greater (1) Max 2

[11]

**119.** Experiment

2 light gates (1)

Gate gives time trolley takes to pass [ not just 'the time'] (1)

Speed = length of 'interrupter'/time taken (1)

OR

2 ticker timers (1)

Dots at known time intervals (1)

Speed = length of tape section/time taken (1) 3

[ruler + clock could obtain third mark only, specifying a length/time]

Total momentum of trolleys

Zero (1)

It was zero initially **or** momentum is conserved [consequent] (1) 2

Speed  $v$  of A

Use of momentum = mass  $\times$  velocity (1)

Use of mass  $\times$  speed (A) = mass  $\times$  speed (B) (1)

1.8 m s<sup>-1</sup> [ignore -ve signs] (1) 3

[8]

**120.** Explanation of why kicking a door is more effective

Quality of written communication (1) 1

Foot decelerates/ loses momentum (1)

This takes place rapidly giving a large force by Newton 2 or equation versions [consequent] (1)

Door is providing this force [consequent on mark 1] (1)

Door acts on foot; by 'Newton 3' foot acts on door' (1) Max 3

[4]

**121.** Free-body force diagram

Normal reaction/contact force [or Nor R or push of table] upwards (1)

E-M/Magnetic force [or magnetic attraction or pull of magnet] to right (1)

Weight [or W or mg or gravitational force or gravitational attraction or pull of Earth] downwards (1) 3

[Ignore labelled forces of fiction. or drag] [if unlabelled -1 each force]

Forces

Pull on earth (1)

Upwards [consequent] (1)

OR

Push/contact force/force on table (1)

Downwards [consequent] (1)

OR

Force on magnet X (1)

To left [consequent] [allow ecf] (1)

2

[5]

**122. Precautions**

Measure background radiation //shield apparatus (1)

Subtract it off/ because it may vary//to eliminate background (1)

Repeat the count and average (1)

Because count (or emission) is random/varying (1)

Source the same distance from GM on both occasions (1)

Because count rate varies with distance (1)

Max 3

[NB Marks must come from any TWO precautions.]

Ratio

0.88 or 1.1 [min. 2 sfi [not %] (1)

1

Count for year 3

11 994 (1)

1

Graph

Suitable axes and scales [don't award if factors 3, 7 used] [not Bq] (1)

Correct plotting of points (1)

Use of curve and halving count rate (1)

5.3 to 5.4 yr (1)

4

[9]

**123. Name of nuclei**

Isotopes [not radioisotopes] (1)

Nuclear equation

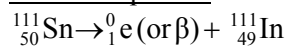

Electron numbers correct anywhere (1)

Correctly balanced (1)

Densest material

Sn-115 (1)

[4]

**124. Gradient**

Use a gradient or use of  $v = u + at$  (1)

10 (either no unit or  $\text{m s}^{-2}$ ) (1)

[A bare answer of 9.8 gets no marks; A bare answer of 10 gets 2 marks]

Significance

It is the acceleration (due to gravity) or close to  $g$  (1) 3

Ball at point A

It hit the floor/bounces/(idea of collision with floor) (1) 1

Calculation of height of window above ground

An area / quote an equation of motion (1)

Put in relevant numbers for large triangle / correct substitution  
[ecf from first part, or use of 9.8] (1)

45 m [accept 44 to 46] (1) 3

[7]

125. Free-body force diagrams

Tension/T/pull of string/NOT pull of ceiling  
Reaction force from string/Contact force from string (1)

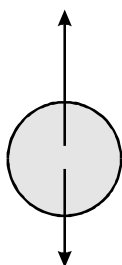

Weight/W/mg/pull of Earth/ $F_g$   
gravitational pull/NOT gravity

Situation 1

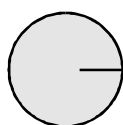

Gravitational force /  
pull of Sun / weight/  
 $F_g/mg$

Situation 2

[Cancel a mark for every extra force (within each diagram); correct line of action required; penalise “gravity” once only.]

Force	Newton’s third law pair, noting its direction and the body on which it acts	
Weight	On Earth.....Upwards	(1)
Tension	On string.....Downwards [N.B. allow ecf from ceiling pull in previous part]	(1)
Gravitational force	On Sun.....Towards Earth/to the left	(1)

[No other ecfs from incorrect forces: “in opposite direction” penalise once only.] 3

[6]

126. Mass approximately 4 kg

Use of volume =  $\pi r^2 \times h$  (1)

Use of mass = their volume above  $\times$  density (1)

Mass = 3.75 (i.e.  $\approx 4$ ) [no u.e.] [Must be calculated to 2 significant figures at least] (1)

3



Calculation of change in g.p.e

Use of  $\Delta \text{g.p.e} = mg\Delta h$  (ecf from above) (1)

39 – 44 J (positive or negative) (1) 2

Calculation of average power output

Use of Power = energy/time or use of  $P = Fv$  ( $v = 1.8 \times 10^{-6} \text{ m s}^{-1}$ ) (1)

Correct conversion of time into seconds (604 800 s) (1)

6.4 –  $7.3 \times 10^{-5} \text{ W}$  [e.c.f. gpe above] (1) 3

[Answer in J/day, J/week, J/hour – can get 2 marks, i.e. 1<sup>st</sup> and 3<sup>rd</sup> marks]

[8]

**127.** Explanation in terms of principle of moments

Large distance ratio (1)

can lead to a small effort/load ratio [consequent] (1) 2

OR

Large distance from the pivot can lead to a small force needed (1)

to produce the same moment/to balance moments [consequent] (1)

OR (1)

Larger distance from the pivot gives a larger moment (1)

which can balance moments [consequent]

[No reference to Earth needed]

Practicality of Archimedes' suggestion

Any two from:

Where would you stand?/What pivot?/Lever would need to be too long,/Lever likely to break/Earth is already moving,/Difficulty of applying a force in space (1) (1) 2

[4]

**128.** (a) Newton's second law of motion

Rate of change of momentum  $\propto$  (OR =) force/

Force = mass  $\times$  acceleration /  $F \propto$  (OR =)  $ma$  with symbols defined/

$a \propto F$  and  $a \propto 1/m$  with symbols defined (1)

Acceleration or (rate of) change of momentum in direction of force (1) 2

Description of demonstration that acceleration is proportional to resultant force

Technique for reducing/compensation for friction (1)

e.g. Air track/friction compensated runway/low friction wheels or track/slight slope drawn or mentioned [not if slope used to vary the force] / smooth runway

Correct technique for applying a constant “known” force (1)

e.g. Forcemeter/elastic of constant length/slope where  
 $F = mg \sin \theta$  / mass on string and pulley if masses are small or moved from pulley to trolley

Apparatus for measuring acceleration (1)

e.g. Ticker timer/ light gate plus double interrupt/ two light gates plus one interrupt/ motion sensor/ strobe camera/ video

Principle behind the measurement (1)

e.g. gives position at known time intervals or times for known distances

Vary  $F$  (1)

Graph of  $a$  versus  $F$  should be a straight line through the origin (1) **Max 5**  
OR values of  $F/a$  are constant

(b) Explanation of observations

Quality of written communication (1) 1

Pencil is accelerating/increasing momentum (1)

This requires a forward force (1)

Back edge of shelf pushes forwards (1)

Converse argument for deceleration (1)

OR

Pencil travels at constant velocity / constant momentum little acceleration / stays at rest (1)

In line with Newton I/due to its inertia/because little or no force on it (1)

If car accelerates, it “catches up” with pencil (1)

Converse argument for deceleration (1) 4

[12]

129. Amount of work done by each of the forces

(Each of the forces does) zero (1)

Forces perpendicular to motion [consequent] (1) 2

[No marks if imply that work = 0 because forces cancel]

Determination of force  $F$

Use of gradient seen/implied (1)

$F = 2.7 - 2.9$  N (1) 2

Graph

Straight line finishing at (1.8, 0) (+ or – 1 small square) (1)

Starting at (0, 5) (+ or – 1 small square) (1) 2

Calculation of speed

Use of  $k.e. = \frac{1}{2}mv^2$  / use of  $F = ma$  and equation of motion (1)

$v = 3.5 \text{ ms}^{-1}$  (ecf) (1) 2

Sketch of graph

Ascending line whose gradient decreases as  $d$  increases (1) 1

Shape of graph

Force greater at higher speed/gradient is the force/force decreases with distance (1) 1

[10]

**130.** Number of neutrons

8 (1)

Decay constant

Use of  $\lambda = 0.69/t_{1/2}$  (1)

$\lambda = 1.2 \times 10^{-4} \text{ yr}^{-1}$  OR  $3.9 \times 10^{-12} \text{ s}^{-1}$  (1) 3

Number of nuclei

$3.0 \times 10^{14}$  (1)

Calculation of activity

Their  $N \times$  their  $\lambda$  (1)

= 1170 Bq [No e.c.f. if **no** conversion to seconds] (1) 3

Nuclear equation

${}^{14}_6\text{C} \rightarrow {}^{14}_7\text{N} + {}^0_{-1}e$  (1) (1) 2

[8]

[1 mark for  ${}^{14}_7\text{N}$ , 1 mark for  ${}^0_{-1}e$  as  ${}^0_{-1}\beta$ ]

[Must be on correct side of arrow]

**131.** Outline of evidence from Geiger's and Marsden's scattering experiment

Most alpha particles went (almost) straight through (1)

Some or a few deflected at larger angles/ $>90^\circ$ /rebounded (1)

A tiny minority [e.g. 1 in 8000] were deflected at angles  $> 90^\circ$  OR rebounded (1) 3

Suggestion

No large deflections/all go (almost) straight through (1)

Explanation

No concentrated charge/mass OR no massive object (to hit) no dense object to hit [consequent] (1) 2

[5]

<b>132. <u>Magnitude of resultant force</u></b>	
4 cm line S / 1.7 cm line N	1
8 cm line NE / 8N resolved into two perp. components (5.7E & 1.7N or 5.7N)	1
Correct construction for vector sum	1
5.7-6.1N	1
<u>Name of physical quantities</u>	
Vectors	1
<u>Two other examples</u>	
Any two named vectors other than force (if >2, must all be vectors)	1

[6]

<b>133. <u>Acceleration of free fall</u></b>	
Advantage:	
So time/distance can be measured more precisely/accurately [Allow reaction time less important]	1
Disadvantage:	
Air resistance becomes important [NOT air resistance acting for longer time ]/may reach terminal velocity/harder to hit trap door	1
<u>Experimental method</u>	
Diagram:	
Labelled start mechanism (any part)	1
Labelled stop mechanism (any part)	1
Releasing ball starts timer	1
Ball opening trap door/switch stops timer	1
OR	
Diagram:	
Ticker timer	1
Tape from sphere through timer [at least one labelled]	1
Timer makes dots at known rate	1
Time = number of spaces × time interval between dots	1
OR	
Diagram:	
Camera	1
Strobe lamp	1
Lamp flashes at known frequency	1
Time = number of spaces between images × time interval between flashes	1

OR	
Diagram	
Light gate joined to timer	1
Second light gate also joined to timer [one labelled]	1
Ball passing gate starts timer	1
Ball passing second gate stops timer	1
OR	
Diagram	
Labelled stopwatch -one mark only out of 4	1
OR	
Diagram	
Motion sensor labelled	1
At top or bottom	1
Produces distance time graph/pulses emitted at known time intervals	1
Time read off from graph	1
OR	
Diagram	
Video camera	1
At side	1
Frames at known frequency/time interval	1
Time = no. of frames $\times$ time interval	1
<u>Statement</u>	
Weight = mass $\times$ $g$ (allow ' $W = mg$ ')	1
$g$ is the same (for all objects) [NOT 'gravity' is constant]	1

[8]

134. Addition to diagram

Downwards arrow $Y$ through middle third of left leg	1
Downward arrow $Z$ with correct line of action	1
[Ignore lengths of arrows and point of action]	
[Must have at least one correct label to get 2 marks; no labels gets max 1 out of 2]	
[One correct label can get 2 marks]	
<u>Explanation</u>	
Quality of written communication	1
Clockwise moments = Anticlockwise when balanced	1
$Y$ is smaller than $X$ , but acts further from $P$	1
Moment of $X = X \times XP$ / Moment of $Y = Y \times YP$	1
$Z$ has little or no moment about $P/Z$ acts through $P$	1

[7]

<b>135. <u>Gravitational potential energy</u></b>		
Use of $mgh$		1
Vertical drop per second = $(8.4 \text{ m}) \sin (3^\circ)$		1
$3.9 \times 10^2 \text{ J/Js}^{-1}/\text{W}$		1
<u>What happens to this lost gpe</u>		
Becomes internal energy/used to do work against friction and/or drag/heat/thermal energy. [mention of KE loses the mark]		1
<u>Estimate of rate at which cyclist does work</u>		
Rate of working = $2. \times 3.9 \times 10^2 \text{ W}$		1
$=7.8 \times 10^2 \text{ W}$		1
[ $3.9 \times 10^2 \text{ W}$ earns 1 out of 2]		
		<b>[6]</b>

<b>136. <u>Momentum and its unit</u></b>		
Momentum = mass $\times$ velocity		1
$\text{kg m s}^{-1}$ or $\text{N s}$		1
<u>Momentum of thorium nucleus before the decay</u>		
Zero		1
<u>Speed of alpha particle/radium nucleus and directions of travel</u>		
Alpha particle because its mass is smaller/lighter		1
So higher speed for the same (magnitude of) momentum OR N3 argument		1
Opposite directions/along a line		1
		<b>[6]</b>

<b>137. <u>Nuclear equation</u></b>		
${}_{49}^{115}\text{In} \rightarrow {}_{50}^{115}\text{Sn} + {}_{-1}^0\text{e}/{}_{-1}^0\beta$		
Correct symbol and numbers for tin OR beta		1
Correct symbols and numbers for the other two		1
<u>Decay constant</u>		
Use of $\lambda = 0.69/t_{1/2}$		1
$1.57 \times 10^{-15} \text{ y}^{-1}$ OR $4.99 \times 10^{-23} \text{ s}^{-1}$		1
<u>Activity of source and comparison with normal background count rate</u>		
Use of $A = \lambda N$ .		1
0.11/0.12 (Bq)		1
Lower (than background) [Allow ecf- assume background = 0.3 to 0.5]		1
		<b>[7]</b>

138. Radiation tests

Alpha:

Test 2 or 2 and 1 1

Count drops when alphas have been stopped by the air / alphas have a definite range / (only) alpha have a short range (in air) 1

Beta:

Test 3/3 and 1, because 1 mm aluminium stops (some) beta/does not stop any gamma rays 1

Gamma:

Test 4 or 4 and 1, because 5 mm aluminium will stop all the betas, (so there must be gamma too) / gamma can penetrate 5 mm of aluminium 1

[4]

139. Table

	Alpha scattering	Deep inelastic scattering
Target	<b>Gold atoms/gold foil/ gold leaf/gold film/very thin sheets of gold/metal foil etc. [NOT thin gold sheet]</b>	<b>Protons/neutrons/nucleons /liquid hydrogen/nuclei</b>

2

Conclusions

(i) Atom mainly empty space/nucleus is very small 1

Nucleus dense/massive 1

(ii) Nucleons have a substructure 1

Made of quarks 1

[6]

140. (i) Distance travelled

Attempt to find area under curve/use of suitable equations (1)

Distance = 300 m (1)

(ii) Average speed

Use of total distance/20 (1)

Average speed =  $15 \text{ m s}^{-1}$  [e.c.f. distance above] (1)

[4]

141. Average deceleration

Select  $v^2 = u^2 + 2ax$ ,  $\frac{1}{2} m v^2 = Fx$  and  $F = ma$  OR equations of motion (1)

Correct substitutions of 40 m and  $25 \text{ m s}^{-1}$  (1)

$a = 7.8 \text{ m s}^{-2}$  [If  $a = -7.8 \text{ m s}^{-2} \rightarrow 2/3$ ] (1) 3

Depth of sand and stopping distance

More sand  $\Rightarrow$  shorter stopping distance/stops more quickly/slows down faster **Because** lorry sinks further/ bigger resisting force / bigger friction force (1)

1

[4]

142. Isotope

Different	Same
Number of neutrons Neutron number Nucleon number Atomic mass Mass number	Number of protons Proton number Atomic number

(1)

1

Two nuclides

Circle(s) on both isotopes with  $Z = 90$  OR  $Z = 92$  (1)

1

Grid

Alpha decay correct Z correct A changes (1)

SW line *from* any one of (238, 92); (234, 92); (230, 90) (1)

Beta change horizontal line (1)

[-1 if missing any arrows; -1 if both labels missing]

Y (234, 90) and X (234, 91) OR Y (234, 91) X (234, 92) (1)

[Allow ecf is correctly drawn  $\beta$  decay shown]

$e$  (0, -1) (1)

5

[7]

143. Alpha particle scattering experiment

Quality of written communication (1)

Most alpha went straight through/deflected very little (1)

A tiny minority were deflected through large angles /  $> 90^\circ$  (1)

Atom had a dense/massive nucleus (1)

Most of the atom was empty space/small nucleus (1)

[5]

144. Resultant force

4 N to the right / 4 N with correct arrow (1)

1

Motion of object

(i) Constant velocity /  $a = 0$  / constant speed (1)

(ii) Accelerates upwards (1)

(iii) Slows down (1)

3



Student's argument

The forces act on different bodies (1)

Therefore cannot cancel out / there is only one force acting on the body [consequent]

2

[6]

**145. Graph**

Sensible scale + point (0, 192) plotted (1)

Rest of points [ -1 mark for each misplot] (1) (1)

3

[(1,96); (2, 48); (4, 12)]

[Accept bar chart]

Random process

Cannot predict which nuclei will decay/when a particular nucleus will decay (1)

1

Model

Cannot predict which children will flip a head/which coins will be heads/when a particular coin /child will flip a head (1)

1

Half-life

Time taken for activity/count rate to drop by half/time taken for half the atoms/nuclei to decay (1)

1

How model illustrates half-life

Yes, if children were told to flip coin at regular time interval

OR

Yes, because about half of the children flipped a head each time

OR

No, because time is not part of the experiment (1)

1

[7]

**146. Mass of head of mallet**

Selecting density x volume (1)

Correct substitutions (1)

Mass = 1.15 (kg) [3 significant figures, minimum] (1)

3

Momentum change

$p = mv$  used (1)

$\Delta p = 1.15$  or  $1.2$  kg  $(4.20 + 0.58)$  m s<sup>-1</sup> (1)

$= 5.50 / 5.74$  kg m s<sup>-1</sup>/N s (1)

3

Average force

Their above / 0.012 s (1)

$F = 458/478$  N [e.c.f.  $\Delta p$  above] (1)

2

Value for force

Handle mass/weight/ head weight/force exerted by user (handle) neglected (1)

1

Effectiveness of mallet with rubber head

$\Delta t$  goes up/ $\Delta p$  goes up (1)

$\Rightarrow$  less force, less effective/more force, more effective [consequent] (1)

2

[11]

**147.** Vehicle movement

$mgh$  and  $\frac{1}{2}mv^2$  [Both required] /  $mgh$  and  $mgh / \frac{1}{2}mv^2$  and  $\frac{1}{2}mv^2$  (1)

1

Expression for speed

Kinetic energy gained = gravitational potential energy lost /

$$mgh = \frac{1}{2}mv^2 \text{ (1)}$$

$$v = \sqrt{(2gh)} \text{ (1)}$$

2

Assumption

No friction/air resistance/rolling (1)

1

Explanation

Yes, because C is lower than A / potential energy is lower at C than at A (1)

Yes so it will still have some kinetic energy at C (1)

No because:

Frictional forces do act to slow the vehicle (1)

even though C is lower than A the vehicle has insufficient kinetic energy to reach C (1)

2

[6]

**148.** Total mass

$$m = 77.5 / 76 \text{ kg (1)}$$

1

Painter on plank

(i) *Either*

Moment of Q about A, B or C would get smaller (1)

Distance remains the same (1)

*Or*

Moment of Q about A, B or C gets smaller (1)

As the moment of the painter/X about A, B or C gets smaller (1)

2

(ii) Plank would start to tilt/painter would fall (1)

Use of  $P = 980$  (N) or choosing B to take moments about (1)

Use of POM (1)

0.41 m (1)

4

Explanation of how value of  $l$  would change if painter had smaller mass and how painter could avoid  $Q$  reaching zero

Lighter painter produces a smaller moment (at a given distance) / lighter painter can stand a further distance from a pivot for the same moment (1)

$\Rightarrow l$  goes down [consequent] (1)

Move support(s) to end of plank/move B to position A / put heavy weight to right of B (1)

3

[10]

149. Table

Type of force	Example	
Gravitational	Weight/attraction between two masses	(1)
Electromagnetic	Normal reaction/friction/drag/tension/force between two charges or magnets/ motor effect/ elastic strain forces/contact forces	(1)
Nuclear	Strong/Weak/force keeping protons (and/or neutrons) together/beta decay/forces within nucleus	(1)

3

Forces

Any three from:

- same type (1)
- same magnitude/equal (1)
- act on different bodies/exerted by different bodies (1)
- opposite direction (1)
- same line of action (1)
- acts for same time (1)

Max 3

[6]

**150. Deceleration of trolley**

Select  $v^2 = u^2 + 2ax$  /both appropriate formulas (1)

Correct substitutions (1)

0.309 [2 significant figures minimum](1) 3

Frictional force

Use of  $F = ma$  (1)

8.7 / 8.6 N [8.4 if 0.3 used] (1) 2

Power

Use of  $P = Fv$  (1)

9.6 / 9.5 W [9.2 if 0.3 used] (1) 2

Force

Use of  $a = (v - u)/t$  (1)

Add 8.6 /8.7 N to resultant force [8.4 if 0.3 used] (1)

42.8 N [42.6 if 0.3 used] [Accept 42.2 N] (1) 3

**[10]**

**151. Explanation**

Some energy converted to internal energy [or heat or sound] / work done against friction [or air resistance] (1) 1

Experiment

Measure  $v$  at the bottom (1)

Suitable apparatus, e.g. motion sensor and data logger/light gate(s) and timer or computer (1)

Detail of technique, e.g. sensor sends pulses at regular time intervals and time to return is measured/gate measures time for card of known length to pass/tickertape measures length between dots made at regular time intervals (1)

Measure mass of trolley with balance (1)

Calculate kinetic energy from  $mv^2/2$  (1)

Measure vertical drop with ruler (1)

Calculate (gravitational) potential energy from  $mgh$  (1)

Calculate  $\frac{ke}{gpe} \times 100$  Max 6

**[7]**

**152. Diagram**

Arrow to right, at A, labelled *Y* (1) 1

Force *X*

Correct use of P of M (1)

1.84 kN (1) 2

Explanation

Vertical forces approximately through A / vertical forces (1) approximately through pivot 1

Force *Y* calculation

1.84N – 0.31 N/use of principle of moments (1)

1.53 kN (1) 2

Explanation

If cut low down, distance to “pivot” is small (1)

Moment produced by force is small/very large force needed to give (1) 2

sufficient moment

[8]

**153. Momentum**

Use of  $p = mv$  (1)

Total momentum = 0.32 kg m s<sup>-1</sup> or N s (1) 2

Velocity

Use of conservation of momentum (1)

0.062 m s<sup>-1</sup> [Allow e.c.f. from wrong first answer] (1)

East/in same direction as B moved originally (1) 3

[Only award last mark if momenta subtracted in first part]

[5]

**154. Isotopes**

same	different	
Number of protons	Number of neutrons	
Atomic number	Neutron number	
Element	Nucleon number	
Proton number	Atomic mass	
	Mass number	(1) 1

Polonium decay

Po at (84, 210) with label (1)

2 steps west (1)

4 steps south (1)

3

Experimental check

Use of GM tube (1)

Inserting sheet of paper/aluminium foil/very thin aluminium/a few cm of air stops the count (1)

Measure background, and look for count rate dropping to background (1)

3

**NB Award points 2 and 3 for correct converse argument.**

**[7]**

**155.** Meanings of terms

Range: distance travelled (before being stopped) (1)

Ionises: removes electron(s) from atoms (1)

2

Explanation

More strongly ionising means shorter range (1)

ionising means energy lost (1)

2

Mass

Use of  $m = \rho V$  (1)

8.1 kg (1)

2

Thickness of lead sheet

Use of  $8.1 \text{ kg}/\rho$  OR  $t$  proportional to  $1/\rho$  (1)

0.7 mm (1)

2

**[8]**

**156.** Rutherford scattering experiment

Most went (nearly) straight through (1)

A small proportion deflected through large angles (1)

2

Arrows to diagram

Two arrows directed away from N (1)

1

Sketch graph

Speeds equal at A and B (1)

A non-zero minimum at P (1)

2

Shape of graph

A to P: Force (component) against velocity so decelerates (1)  
P to B: Force (component) in direction of velocity so accelerates (1) 2

Add to diagram

Same initial path but deflected through larger angle (1) 1

Observations

More alpha particles deflected/ alphas deflected through larger angles/fewer pass straight through (1) 1

[9]

**157.** Six physical quantities

Momentum (1)

Power / force (1)

Power (1)

Power (1)

Moment **and** energy (1)

[5]

**158.** Momentum of neutron

Use of  $p = m v$  (1)

$p = 5.03 \times 10^{-20} \text{ N s/kg m s}^{-1}$  (1) 2

Speed of nucleus

Total mass attempted to be found (1)

Conservation of momentum used (1)

$v = 2.01 \times 10^6 \text{ m s}^{-1}$  [ecf from  $p$  above only] (1) 3

Whether collision was elastic

Use of  $\text{k.e.} = \frac{1}{2} m v^2$  (1)

$\text{ke} = 7.45 \times 10^{-13} \text{ (J)} / 5.06 \times 10^{-14} \text{ (J)}$  (ecf) (1)

A correct comment based on their two values of ke. (1) 3

[8]

**159. Maximum velocity**

Area = 100 m (1)

Attempt to find area of trapezium by correct method (1)

$$v = 10 \text{ m s}^{-1} \text{ (1)}$$

3

Sketch graph

Horizontal line parallel to x axis

Some indication that acceleration becomes  $0 \text{ m s}^{-2}$

The initial acceleration labelled to be  $v_{\text{max}} \div 2$  [ initial  $a = 5 \text{ (m s}^{-2}\text{)} \text{ (1)}$   
(ecf)]

$t = 2 \text{ (s)}$  where graph shape changes (1)

4

[7]

**160. Nuclear equation for decay of isotope**

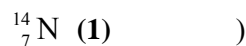

3

Value for  $n$

-14 to -15 (1)

1

Density of nucleus

Use of  $D = m/V$  (1)

Use of nucleus as sphere/cube (1)

If the nucleus is thought of as a cube:

$$\text{and } n = -14, \text{ then } D = 2 \times 10^{16} \text{ kg m}^{-3}$$

$$\text{and } n = -15, \text{ then } D = 2 \times 10^{19} \text{ kg m}^{-3}$$

If the nucleus is thought of as a sphere:

$$\text{and } n = -14, \text{ then } D = 3.8 \times 10^{16} \text{ kg m}^{-3}$$

$$\text{and } n = -15, \text{ then } D = 3.8 \times 10^{19} \text{ kg m}^{-3}$$

[e.c.f. candidate's  $n$ ] (1)

3

Comment on value

Liquids/solids have densities  $\approx 10^{3-4} \text{ (kg m}^{-3}\text{)}/\approx 10^{0-1} \text{ g cm}^{-3} \text{ (1)}$

» /much greater (1)

2

[9]



**161. Decay constant**

$\lambda = 0.69/432 \text{ (yr}^{-1}\text{)} \text{ (1)}$

$\lambda = 5.1 \times 10^{-11} \text{ (s}^{-1}\text{)} \text{ [At least 2 significant figures] (1)}$  2

Number of nuclei

$3.0 \times 10^{13} \text{ (1)}$  1

Activity calculation

Use of  $A = \lambda N \text{ (1)}$

$A = 1.5 \times 10^3 \text{ Bq / s}^{-1} \text{ [ecf] (1)}$  2

Explanation

Range few cm in air / short range (1)

Alpha would produce enough ions (to cross gap) OR ionises densely/strongly/highly (1) 2

Features of americium sample

Half-life long enough to emit over a few years (1)

Count well above background (1)

Suitable as safe as range very low / shielded (1) 3

**[10]**

**162. Description of how claim could be tested experimentally**

Apparatus [i.e. (i)]

[NB 1 mark per row from table; no mixed methods]

<b>Tickertape</b>	<b>Light gate(s)</b>	<b>Motion sensor</b>	<b>Video</b>	<b>(1)</b>
Tickertimer	Datalogger/PC	Datalogger/PC	m scale	<b>(1)</b>

How apparatus is used [i.e. (ii)]

How the apparatus gives a velocity ie that it measures distance and (1) time

Method measures at least 3 velocities and correct time intervals (1) /distances

Analysis [i.e. part (iii)]

Plot velocity-time graph / calculate 2 or more accelerations (1) [consequent mark]

Straight line indicates uniform acceleration /  $a$  is equal (1) 6

Constant acceleration

(Acceleration is due to) weight of trolley which is constant (1)

Component of weight constant / slope constant (1)

Air resistance is negligible / friction is constant (1)

Max 2

Explanation

No, because air resistance would become significant (1)

1

[9]

**163.** Criticism of statement

Not a Newton third law pair (1)

Forces in equilibrium but not for reason stated (1)

N3 pairs act upon different bodies (1)

N3 pairs same type (1)

Line of action different / rotation (1)

Max 3

Table

Gravitational (1)

Earth (1)

Upwards **and** downwards [**both** must be correct] (1)

Table (1)

4

Force	Type of force	Direction of Newton 3 <sup>rd</sup> law 'pair' force	Body 'pair' force acts upon
Weight	Gravitational	Upwards	Earth
Push of table	Electro-magnetic	Downwards	Table

[7]

**164.** Principal energy transformation

Kinetic energy to internal energy/heat/work done against friction (1)

1

Explanation of braking distance

$Q_0WC$  (1)

Car is (also) losing gpe (1)

Total work done against friction is greater OR more energy to be converted to heat (in the brakes) (1)

Since force is same, distance must be greater [consequent] (1)

4

[5]

165.

Unit	Physical Quantity	
$\text{m s}^{-1}$	<i>Velocity</i>	
$\text{m s}^{-2}$	Acceleration / deceleration	(1)
$\text{kg m}^{-3}$	Density	(1)
$\text{N m}$	Moment / energy / (gravitational)potential energy / kinetic energy/heat/work (done) / torque	(1)
$\text{kg m s}^{-1}$	Momentum / impulse	(1)
$\text{N m s}^{-1}$	Power	(1)

5

[5]

166. (a) Free body force diagram for magnet  
(Electro)magnetic / (force of) repulsion / push (1)



Weight /  $W$  /  $mg$  / pull (of Earth) / gravitational (attractive force) / attraction (of Earth) (1)  
[NOT gravity]  
[An additional incorrect force cancels 1 mark awarded]

2

- (b) Newton's third law pairs

6

Force	Body on which corresponding force acts	Direction of the corresponding force	
Contact	(Wooden) stand/base	Downwards / down / $\downarrow$	(1) (1)
Magnetic	(Magnet) $M_1$	Upwards / up / $\uparrow$	(1) (1)
Weight	Earth / Earth's surface	Upwards / up / $\uparrow$	(1) (1)

[8]

167. (a) Principle of moments

In equilibrium (1)

sum of clockwise moment (about any point) is equal to sum of anticlockwise moment (about that point) (1)

2

- (b) (i) Weight  
 Use of “width x thickness x length” (1)  
 Use of “density =  $\frac{\text{mass}}{\text{volume}}$ ” (1)  
 Correct value (1) 3  
 $V = 1.2 \times 0.6 \times 200 \text{ (cm}^3\text{)} = 144 \text{ (cm}^3\text{)}$   
 Using  $\rho = \frac{m}{V}$ ,  $m = 8 \text{ (g cm}^{-3}\text{)} \times 144 \text{ (cm}^3\text{)} = 1152 \text{ g}$   
 $\text{Weight} = mg = 1152 \times 10^{-3} \text{ (kg)} \times 9.81 \text{ (m s}^{-2}\text{)} = 11.3 \text{ (N)} / 12 \text{ (N)}$
- (ii) Force F  
 Correct substitution into correct formula (1)  
 Correct value with correct unit (1) 2  
 $F \times 60 \text{ (cm)} = 11.3 \text{ (N)} \times 40 \text{ (cm)} / 12 \text{ (N)} \times 40 \text{ (cm)} / 11 \text{ (N)} \times 40 \text{ (cm)}$   
 $= 7.5 \text{ N} / 8 \text{ N} / 7.3 \text{ N}$
- (iii) Force R  
 18.3 N / 18.8 N / 20 N (1) 1
- (iv) Sketch graph  
 Any line upwards(1)  
 Correct shape for F [concave shaped curve](1) 2

**[10]**

168. (a) Moment  
 Correct substitution into correct formula (1)  
 Correct value with correct unit (1) 2  
 Moment = force  $\times$  distance  
 $= 1 \times 10^{-4} \text{ (kg)} \times 9.81 \text{ (N kg}^{-1}\text{)} \times 5 \times 10^{-2} \text{ (m)}$   
 $= 4.9 \times 10^{-5} \text{ N m}$

- (b) Work done  
 Correct substitution of a distance and weight into correct formula (1)  
 Calculation of distance (1)  
 Correct value(1) 3
- Work done = force  $\times$  distance in the direction of the force  
 EITHER  
 Use circumference =  $2\pi r$   
 whence distance =  $\frac{2\pi 5 \times 10^{-2}}{60} = 5.2 \times 10^{-3}$  (m)  
 OR  
 Use  $\sin 6^\circ = \frac{\text{distance}}{5 \times 10^{-2}}$   
 whence distance =  $5 \times 10^{-2} \times 0.1045 = 5.2 \times 10^{-3}$  (m)  
 Work done =  $1 \times 10^{-4}$  (kg)  $\times$   $9.81$  (N kg<sup>-1</sup>)  $\times$   $5.2 \times 10^{-3}$  (m) =  
 $5.1 \times 10^{-6}$  (J)  
 OR  
 Use  $\tan 6^\circ = \frac{\text{distance}}{5 \times 10^{-2}}$   
 whence distance =  $5 \times 10^{-2} \times 0.1051 = 5.3 \times 10^{-3}$  (m)  
 Work done =  $1 \times 10^{-4}$  (kg)  $\times$   $9.81$  (N kg<sup>-1</sup>)  $\times$   $5.3 \times 10^{-3}$  (m) =  $5.2 \times 10^{-6}$  (J)
- (c) Comparison  
 No work is done on the hand to move it horizontally (so value is less) / as movement is perpendicular to force / distance moved in (1) 1  
 direction of force is zero/less / moment is smaller.
- (d) Average power  
 Identifying “power =  $\frac{\text{work done / energy}}{\text{time}}$ ” (1)  
 Correct value with correct unit (1) 2  
 Centre of gravity raised by  $10 \times 10^{-2}$  (m)  
 Work done =  $1 \times 10^{-4}$  (kg)  $\times$   $9.81$  (N kg<sup>-1</sup>)  $\times$   $10 \times 10^{-2}$  (m)  
 =  $9.81 \times 10^{-5}$  (J)  
 Average power =  $\frac{\text{work done}}{\text{time taken}} = \frac{9.81 \times 10^{-5} \text{ (J)}}{30 \text{ (s)}} = 3.3 \times 10^{-6}$  W
- (e) Different design  
 Less/zero work done / less friction / less wear on the mechanism (1)  
 the c of g/weight is not raised OR less/zero moment OR (1)  
 (hand is) balanced/in equilibrium 2

[10]

169. (a) Explanation  
 $V_b$  has a horizontal component equal to  $V_a$  (1)  
 $V_b$  has a vertical component (1) 2  
 [ $V_b$  has two components of velocity is 1 mark]  
 [ $V_b \cos 45 = V_a$  is 2 marks]
- (b) Explanation  
 EITHER

QoWC (1)  
 The average speed / velocity of A is greater (than B) / converse (1)  
 (because) A continually accelerates whereas B slows down / (1)  
 decelerates (initially)  
 [description of both A and B necessary for this 2<sup>nd</sup> physics mark]  
 OR  
 QoWC (1)  
 $V_a$  = horizontal component of  $V_b$  and they travel the same (1)  
 horizontal distance  
 Vertical component of projectile's motion does not affect (1)  
 horizontal motion

3

[5]

170. (a) Energy change

Both parts correct [NB 1 mark only] (1)  
Gravitational potential (energy) to kinetic / movement (energy) /  
 work done

1

(b) Principal of conservation of energy

EITHER (1) (1)  
 Energy can be neither created nor destroyed  
 OR  
 Energy cannot be created/destroyed / total energy is not (1)  
 lost/gained  
 merely transformed from one form to another / in a  
 closed/isolated system (1)

2

(c) Speed of water

Correct substitution into correct formula (1)  
 Correct value with correct unit (1)  
 Power = force  $\times$  velocity  
 $1.7 \times 10^9 \text{ (W)} = 3.5 \times 10^8 \text{ (N)} \times V$   
 $V = 4.86 \text{ m s}^{-1}$

2

(d) Explanation

Not all the energy of the falling water is transferred to the output  
 power OR system is not 100% efficient OR water is not brought (1)  
 to rest OR friction OR some of the energy is transferred to  
 heat/sound/surroundings.

1

(e) Time

Correct value with correct unit. (1)  

$$\text{Time} = \frac{7 \times 10^6 \text{ (m}^3\text{)}}{390 \text{ (m}^3\text{s}^{-1}\text{)}} = 17\,949 \text{ s (= 299 min) (= 5 h)}$$

1

(f) Work done

Correct substitution into correct formula to find mass of water (1)

Identifying

“work done = force x distance moved in direction of force” (1)

Correct value with correct unit (1)

Mass of water = volume × density 3

$$= 7 \times 10^6 \text{ (m}^3\text{)} \times 10^3 \text{ (kg m}^{-3}\text{)} (= 6.9 \times 10^9 \text{ kg)}$$

Work done = force × distance

$$\text{Work done} = 6.9 \times 10^9 \text{ (kg)} \times 9.81 \text{ (ms}^{-2}\text{)} \times 500 \text{ (m)}$$

$$= 3.43 \times 10^{13} \text{ J}$$

[10]

171. (a) (i) Complete equation

Correct identification of  ${}^4_2\alpha$  for  $\alpha$  (1)

Correct substitution (1) 2

${}^{27}_{13}\text{Al}$  OR correct values which balance the candidate's equation

(ii) Completion of 2<sup>nd</sup> equation

${}^0_1\text{e}$  (1)

Correct identification of positron / positive (+ ve) electron /  $\beta^+$  / (1) 2  
antilepton

[If incorrectly given  ${}^0_{-1}\text{e}$  allow electron /  $\beta^-$  ie 1 mark]

[Correct spelling only]

(b) Half-life

Average (1)

Time taken for the activity/intensity/count rate to drop by half

OR time taken for half the atoms/nuclei to decay (1)

[NOT mass, count, particles, radioisotope, sample]

Isotope

Same: proton number / atomic number (1)

[Not same chemical properties]

Different: neutron number / nucleon number / mass number (1)

Max 3

[Not different physical properties/density]

- (c)  $\gamma$ -ray emission 1
- EITHER OR
- (The loss of a helium nucleus/electron has left the remaining) nucleus in an excited state/with a surplus of energy
- The nucleus emits its surplus energy (in the form of a quantum of  $\gamma$ -radiation) (1)

[8]

172. (a) Inelastic scattering 1
- Kinetic energy is not conserved / (some) kinetic energy is 'lost' (1)
- (b) Structure 1
- There are point charges/quarks/smaller particles within the nucleon OR mass not uniform
- (c) Quantity conserved 1
- Momentum / energy / charge / mass (1)
- (d) No information 1
- Electron was repelled (by the (outer) electron shell(s)) OR captured to make an ion.

[4]

173.

<i>Graph</i>	<i>Physical quantity represented by area under graph</i>
(i)	Work (done) / (change in)energy (stored) (1)
(ii)	Distance / displacement (change) (1)
(iii)	Speed / velocity (change) (1)
(iv)	Impulse / (change in) momentum (1)

For ii ignore total if written

For iii average velocity or average speed is wrong

[4]

174. (a) Principle of moments
- For equilibrium / balance (1)
- sum of moments clockwise = sum of moments anti-clockwise (1) 2
- or sum of moments (about a point) is zero
- [Sum or equivalent eg total/net/resultant [NOT all] must be seen at least once]



- (b) (i) Weight of retort stand  
 Use of principle of moments (1)  
 i.e.  $180 \times (10^{-3} \text{ m}) \times W = 228 \times (10^{-3} \text{ m}) \times 9 \text{ (N)}$   
 [Allow 1 wrong distance]  
 11.4 (N) (1) 2  
 [At least 3 sig fig required. No u.e.] [In this question allow reverse calculation to gain full marks] [Bald answer scores 0]
- (ii) Reading on newtonmeter and normal contact  
 Fully correct moment equation (1)  
 $F \times 448 \times (10^{-3} \text{ m}) = 11.4 \text{ (N)} \times 40 \times (10^{-3} \text{ m})$   
 [allow  $11 \text{ N} \times 40 \times (10^{-3}) \text{ m}$  or ecf from (b)(i)]  
 $= 1.0 \text{ N (1)}$   
 Normal contact force  $(11.4 \text{ N}/11 \text{ N} - 1 \text{ N}) = 10.4 \text{ N}$  or  $10 \text{ N (1)}$  3  
 (upwards)[ecf]

[7]

175. (a) Calculation of weight  
 Use of  $L \times W \times H$  (1)  
 Substitution into density equation with a volume and density (1)  
 Correct answer [49.4 (N)] to at least 3 sig fig. [No ue] (1) 3  
 [Allow 50.4(N) for answer if 10 N/kg used for g.]  
 [If 5040 g rounded to 5000 g or 5 kg, do not give 3<sup>rd</sup> mark; if conversion to kg is omitted and then answer fudged, do not give 3<sup>rd</sup> mark]  
 [Bald answer scores 0, reverse calculation 2/3]  
 $80 \text{ cm} \times 50 \text{ cm} \times 1.8 \text{ cm} = 7200 \text{ cm}^3$   
 $7200 \text{ cm}^3 \times 0.70 \text{ g m}^{-3} = 5040 \text{ g}$   
 $5040 \text{ g} \times 10^{-3} \times 9.81 \text{ N/kg}$   
 $= 49.4 \text{ (N)}$   
 [May see :  
 $80 \text{ cm} \times 50 \text{ cm} \times 1.8 \text{ cm} \times 0.7 \text{ g m}^{-3} \times 10^{-3} \times 9.81 \text{ N/kg}$   
 $= 49.4 \text{ (N)}$ ]
- (b) (i) Horizontal and vertical components  
 Horizontal component =  $(83 \cos 37 \text{ N}) = 66.3 \text{ N} / 66 \text{ N (1)}$   
 Vertical component =  $(83 \sin 37 \text{ N}) = 49.95 \text{ N} / 50 \text{ N (1)}$  2  
 [If both calculated wrongly, award 1 mark if the horizontal was identified as  $83 \cos 37 \text{ N}$  and the vertical as  $83 \sin 37 \text{ N}$ ]

- (ii) Add to diagram  
 Direction of both components correctly shown on diagram (1) 1
- (iii) Horizontal force of hinge on table top  
 66.3 (N) or 66 (N) **and** correct indication of direction [no ue] (1) 1  
 [Some examples of direction: acting from right (to left) / to the left / West / opposite direction to horizontal. May show direction by arrow. Do not accept a minus sign in front of number as direction.]

[7]

176. Expression for  $E_k$  and work done / base unit

- (a) (i) Kinetic energy =  $\frac{1}{2} mu^2$   
 Work done =  $Fd$   
 [must give expressions in terms of the symbols given in the question] (1) 1
- (ii) Base units for kinetic energy =  $(\text{kg (m s}^{-1}\text{)}^2) = \text{kg m}^2 \text{ s}^{-2}$  (1)  
 Base units for work done =  $\text{kgms}^{-2} \cdot \text{m} = \text{kg m}^2 \text{ s}^{-2}$  (1)  
 [derivation of  $\text{kg m}^2 \text{ s}^{-2}$  essential for 2<sup>nd</sup> mark to be given] 2  
 [Ignore persistence of  $\frac{1}{2}$ ] [ For 2<sup>nd</sup> mark ecf  $mgh$  for work from (a)(i)]

- (b) Show that the braking distance is almost 14 m

[Bald answer scores 0; Reverse calculation max 2/3]

**Either**

Equating work done and kinetic energy [words or equations] (1)

Correct substitution into kinetic energy equation **and** correct substitution (1) into work done equation

Correct answer [13.8 (m)] to at least 3 sig fig. [No ue] (1)

$$0.5 \times m \times (13.4 \text{ m s}^{-1})^2 = m \times 6.5 \text{ m s}^{-2} \times d$$

$$\frac{0.5 \times m \times (13.4 \text{ ms}^{-1})^2}{m \times 6.5 \text{ ms}^{-2}} = 13.8 \text{ (m)} \quad 3$$

[ $m$  may be cancelled in equating formulae step and not seen subsequently]

**OR**

Selecting  $v^2 = u^2 + 2as$  OR 2 correct equations of motion (1)

Correct magnitudes of values substituted (1)

$$[\text{i.e. } 0 = (13.4 \text{ m s}^{-1})^2 + 2((-)6.5 \text{ m}^{-2}\text{s})]$$

Correct calculation of answer [13.8 (m)] to at least 3 sig fig. [No ue] (1)

- (c) Why braking distance has more than doubled

QOWC (1)

**Either**

(Because speed is doubled and deceleration is unchanged) time (1) (to be brought to rest) is doubled/increased.

(Since) distance = speed x time [mark consequent on first] or  $s = ut + \frac{1}{2} at^2$  (1) the distance is increased by a factor of (about) 4 (1) 4

**Or**

Recognition that (speed)<sup>2</sup> is the key factor (1)

Reference to  $v^2 = u^2 + 2as$  or rearrangement thereof or kinetic energy (1)

[second mark consequent on first]

(Hence) distance is increased by a factor of (almost) 4 (1)

**Or**

Do calculation using  $v^2 = u^2 + 2as$  and use  $26.8 \text{ m s}^{-1}$  and  $6.5 \text{ m s}^{-2}$  (1)

Some working shown to get answer 55.2 m (1)

(Conclusion that) distance is increased by a factor of (almost) 4

[Note : unlikely that QOWC mark would be awarded with this method] (1)

**Or**

Accurate labelled  $v-t$  graphs for both (1)

Explanation involving comparison of areas (1)

Distance is increased by a factor of (almost) 4 (1)

[In all cases give 4<sup>th</sup> mark if 4 is not mentioned but candidate shows more than doubled eg “Speed is doubled and the time increased, therefore multiplying these gives more than double.”]

[10]

177. (a) From what height?

Use of  $mg\Delta h$  and  $\frac{1}{2}mv^2$  (1)

[ignore power of 10 errors]

$$mg \Delta h = \frac{1}{2}mv^2 \quad (1)$$

[shown as formulae without substitution, or as numbers substituted into formulae]

Answer [0.8(2) m] (1)

[It is possible to get 0.8 m by a wrong method:

- If  $v^2 = u^2 + 2as$  is used, award 0 marks
- If you see  $v^2/a$  then apply bod and up to 2/3 marks – the 2<sup>nd</sup> and 3<sup>rd</sup> marks. Note that  $v^2/g$  is correct and gains the first 2 marks, with the 3<sup>rd</sup> mark if 0.8 m is calculated]

3

$$80 \times (10^{-3}) \text{ kg} \times 9.81 \text{ N kg}^{-1} \times \Delta h = \frac{1}{2} \times 80 \times (10^{-3}) \text{ kg} \times (4 \text{ m s}^{-1})^2$$

$$h = \frac{0.5 \times 80 \times 10^{-3} \text{ kg} \times (4 \text{ m s}^{-1})^2}{80 \times 10^{-3} \text{ kg} \times 9.81 \text{ N kg}^{-1}}$$

$$= 0.8(2) \text{ m}$$

(b) (i) Law of conservation of linear momentum

Provided no external [other/resultant/outside] force acts (1)

The total momentum (of a system) does not change / total momentum (1)

before(collision) = total momentum after (collision)

2

[Total seen at least once] [Ignore all references to elastic and inelastic]

[Do not credit simple statement that momentum is conserved]

(ii) Speed of trucks after collision

Any correct calculation of momentum (1)

Use of conservation of momentum leading to the answer  $1.3(3) \text{ m s}^{-1}$  (1)

$$80 \times (10^{-3}) \text{ kg} \times 4 \text{ m s}^{-1} = 240 \times (10^{-3}) \text{ kg} \times u, \text{ giving } u = 1.3(3) \text{ m s}^{-1} \quad 2$$

(c) Time for trucks to stop

[Do not penalise candidates for using a total frictional force of 0.36 N.  
3/3 possible]

**Either**

Correct use of power =  $f \times v$  and  $\frac{1}{2} mv^2$  (1)

[Do not penalise power of 10 errors or not dividing by 2 in  $f \times V$  equation]

Use of energy divided by power (1)

Answer in range 2.6 s to 2.7 s (1)

[ecf their value for  $u$ ]

$$P = 0.12 \text{ N} \times \frac{1.33}{2} \text{ m s}^{-1} = 0.08 \text{ W}$$

$$\text{KE} = \frac{1}{2} \times (3) \times 80 \times (10^{-3}) \text{ kg} \times (1.33 \text{ m s}^{-1})^2 = 0.21 \text{ J}$$

$$\frac{\text{Energy}}{\text{power}} = \frac{0.21 \text{ J}}{0.08 \text{ W}}$$

$$t = 2.6(5) \text{ s}$$

[accept 2.6 or 2.7 as rounding]

3

**OR**

Use of  $F = ma$  (1)

Use of **either**  $v = u + at$  *i.e* **or**  $a = \frac{\Delta v}{t}$  (1)

Answer in range 2.6 s to 2.7 s (1)

$$(-)0.12 \text{ N} = (3) \times 80 \times (10^{-3}) \text{ kg} \times a \quad (a = (-)0.5 \text{ m s}^{-2})$$

$$0 = 1.33 \text{ m s}^{-1} - 0.5 \text{ m s}^{-2} \times t \quad \text{or} \quad (-)0.5 \text{ m s}^{-2} = \frac{(-)1.33 \text{ m s}^{-1}}{t}$$

$$t = 2.6(6) \text{ s}$$

**OR**

Select  $Ft = \Delta p$  (1)

Substitution  $(-)0.12t = (-3) \times 80 \times (10^{-3}) \text{ kg} \times 1.33 \text{ m s}^{-1}$  (1)

Allow omission of any bracketed value]

Answer in range 2.6 s to 2.7 s (1)

[10]

178. (a) (i) Newton's First law of Motion

An object will remain (at rest or) uniform/constant velocity/speed/motion in a straight line unless (an external/impressed) force acts upon it / provided resultant force is zero. (1)

1

- (ii) Everyday situation  
Reference to air resistance / friction / drag etc. (1) 1
- (iii) Equilibrium  
The resultant force is zero / no net force / sum of forces is zero / forces are balanced / acceleration is zero (1) 1  
[Accept moments in place of force]
- (b) (i) Identify the other force  
Earth (1)  
Gravitational [consequent on first mark] [Do not credit gravity.] (1) 2
- (ii) Why normal contact forces are not a Newton's third law pair  
Do not act along the same (straight) line / do not act from the same point (1)  
They act on the same body (1)  
They act in the same direction / they are not opposite forces (1)  
They are of different magnitudes (1)  
max 2

[7]

179. (a) Sources of background radiation

**2 from:**

Cosmic rays, rocks, soil, food, nuclear power/industry [buried waste as alternative], atmosphere, building material, medical uses, nuclear weapons testing (in the 60 s), Sun, radon gas 2

[Do not credit more than 1 example in each category e.g. coffee and Brazil nuts is 1 mark not 2]

- (b) (i) Measurement of background count rate
- Use GM tube or stop watch/ratemeter/datalogger (1)
  - All sources must be in their (lead) containers / placed away from the (1) experiment / place thick lead around tube
  - Measure count over measured period of time (1)  
(and divide count by time)
  - Repeat and average / measure the count for at least 5 minutes (1)
  - Subtract background (count rate) from readings (1)
- max 4
- (ii) Why it might be unnecessary to measure background count rate  
Count rate for the radioactive material is much greater than the background count rate. (1) 1  
[Comparison required with count rate of radioactive material]

[7]

180. (a) (i) Stable ?  
Will not: decay / disintegrate / be radioactive / emit radiation / emit (1) 1  
particles / break down  
[Do not accept will not emit energy]

(ii) Complete equation

$${}^1_1\text{Y} \quad (1) \quad 1$$

(iii) Identify particles

X = neutron (1)  
Y = proton (1) 2

(b) (i) Decay Constant

$$\text{Use of } \lambda = \frac{0.69}{t_{1/2}} \text{ i.e. } = \frac{0.69}{5568 \times 3.2 \times 10^7 \text{ s}} \quad (1)$$

[Do not penalise incorrect time conversion]

Correct answer [  $3.87 \times 10^{-12} \text{ (s}^{-1}\text{)}$ ] to at least 2 sig fig. [No ue] (1) 2  
[Bald answer scores 0]

(ii) Number of nuclei

$$\text{Use of } A = \lambda N \text{ eg } \frac{16}{60} = (-) 4 \times 10^{-12} \text{ N} \quad (1)$$

[Ecf their value of  $\lambda$ ] [Do not penalise incorrect time conversion]

Answer in range  $6.6 \times 10^{10}$  to  $7.0 \times 10^{10}$  (1) 2

[8]

181.

<i>Graph</i>	<i>Physical quantity represented by the gradient</i>
(i)	(Constant) velocity [ <b>Not</b> speed. <b>Not</b> velocity change.] (1)
(ii)	(Constant) acceleration (1)
(iii)	Force (1)
(iv)	Power (1)

Ignore references to units eg velocity  $\text{m s}^{-1}$  or dimensions  $\text{L T}^{-1}$

[4]

182. (a) Complete statement of Newton's Third Law of Motion

....exerts an equal force on (body) A (1)

(but) in the opposite direction (to the force that A exerts on B) (1) 2

[‘exerts an equal but opposite force on body A’ would get both marks]

(b) Complete the table

1 mark for each of the three columns **(1) (1) (1)**

3

[Accept from earth for up. Accept towards ground or towards earth for down]

	Earth	Gravitational. [ <b>Not</b> 'gravity'. <b>Not</b> gravitational field strength]	Up(wards) / ↑
	Ground		Down(wards) / ↓

[5]

**183.** (a) Time to fall

Use of  $s = ut + \frac{1}{2} at^2$  **or** use of 2 correct equations of motion **(1)**

**or** use of  $mgh = \frac{1}{2} mv^2$  and other equation(s)

[allow  $g = 10 \text{ m s}^{-2}$ ]

2

Answer to at least 2 sig fig [0.69 s. No ue] **(1)**

Example

$$2.3 \text{ m} = 0 + \frac{1}{2} 9.8 \text{ m s}^{-2} t^2$$

$$t = 0.68(5) \text{ s} [0.67(8) \text{ if } 10 \text{ m s}^{-2} \text{ used}]$$

[Reverse argument only accept if they have shown that height is 2.4 m]

(b) Time to rise

Select 2 correct equations **(1)**

Substitute physically correct values [not  $u = 0$  or a + value for  $g$ ] **(1)**

[allow  $g = 10 \text{ m s}^{-2}$  throughout] **(1)**

3

Answer: [  $t = 0.38 \text{ s}$  ]

Example 1

$$0 = u^2 + 2x - 9.81 \text{ m s}^{-2} 0.71 \text{ m}$$

$$0 = 3.73 \text{ m s}^{-1} + -9.81 \text{ m s}^{-2} t$$

$$t = 0.38 \text{ s}$$

[0.376 s if  $10 \text{ m s}^{-2}$ ]

Example 2

$$0 = u + -9.81 \text{ m s}^{-2} t; u = 9.81t$$

$$0.71 \text{ m} = 9.81 t.t + \frac{1}{2} -9.81 \text{ m s}^{-2} t^2$$

$$t = 0.38 \text{ s}$$

[**Note.** The following apparent solution will get 0/3.  $s = ut + \frac{1}{2} at^2$ ;

$0.71 \text{ m} = 0 + \frac{1}{2} 9.81 \text{ m s}^{-2} t^2$ ;  $t = 0.38 \text{ s}$ , unless the candidate makes it clear they are considering the time of fall from the wicket.]

- (c) Velocity u  
 Use of  $v \frac{d}{t}$  (1)  
 [d must be 20 m, with any time value from the question eg 0.7 s]  
 Answer: [18.9 m s<sup>-1</sup> or 18.2 m s<sup>-1</sup> if 0.7 s + 0.4 s = 1.1 s is used. (1) 2  
 ecf value for time obtained in (b).]  
 Example  

$$v = \frac{20m}{0.68s + 0.38s}$$

$$= 18.86 \text{ m s}^{-1} \text{ [18.18 m s}^{-1} \text{ if 1.1 s used]}$$
- (d) Why horizontal velocity would not be constant  
 Friction/drag/air resistance/inelastic collision at **bounce or impact** (1) 1  
 / transfer or loss of ke (to thermal and sound) at **bounce or impact**  
 (would continuously reduce the velocity/ kinetic energy).  
 [also allow 'friction between ball and surface when it bounces  
 (will reduce velocity/kinetic energy)'].  
 [Any reference to gravitational force loses this mark.  
 A specific force must be mentioned, eg resistive forces is not enough.]

[8]

184. (a) Newton's Second Law of Motion  
 (The) force (acting on a body) is proportional/equal to the rate of (1)  
**change** of momentum (1)  
 and acts in the direction of the momentum change  
 [accept symbols if all correctly defined for the first of these marks]  
 [ignore any information that is given that is not contradictory] 2
- (i) Calculate the mass  
 Correct calculation for volume of air reaching tree per second  
 [Do not penalise unit error or omission of unit] (1)  
 Correct value for mass of air to at least 3 sig fig [246 kg. No ue.] (1)  
 [If  $1.23 \times 10 \times 20 = 246 \text{ kg}$  is seen give both marks.  
 Any order for the numbers]  
 Example  

$$20 \text{ ms}^{-1} \times 10 \text{ m}^2 = 200 \text{ m}^3$$

$$1.23 \text{ kg m}^{-3} \times 200 \text{ m}^3 = 246 \text{ kg}$$
- (ii) Calculate the momentum  
 Answer: [ (246 kg × 20 m s<sup>-1</sup> =) 4920 kg m s<sup>-1</sup> ]  
 [Accept (250 kg × 20 m s<sup>-1</sup> =) 5000 kg m s<sup>-1</sup>. Accept 4900 kg m s<sup>-1</sup>. (1) 2  
 Ecf value for mass. Ignore signs in front of values.]
- (iii) Magnitude of the force  
 Answer: [F = 4920 N or 5000 N or 4900 N.]  
 [Ecf value from b(ii). Ignore signs in front of values] (1) 2

[6]



**185. (a) Principle of moments**

For equilibrium/balance (1)

sum of clockwise moments = sum of anticlockwise moments or sum of moments about a point is zero. (1)

[Sum or equivalent eg total/net/resultant [Not all] must be seen at least once] 2

(i) Force T

Use of principle of moments [Allow one wrong distance] (1)

Answer: [ $T = 1.25 \text{ N}$ . Accept  $1.3 \text{ N}$ ] (1)

$$T \times 80 \text{ cm} = 1 \text{ N} \times 40 \text{ cm} + 3 \text{ N} \times 20 \text{ cm}$$

$$T = 1.25 \text{ N} \quad 2$$

(ii) Force

Size: [( $1 \text{ N} + 3 \text{ N} - 1.25 \text{ N} = 2.75 \text{ N}$ ). Ecf value of  $T$ ] (1)

Direction: [Up(wards) or same direction as  $T$  or arrow up, might be shown on diagram]. (1) 2

(iii) Bar tilted

Force  $T$  stays the same

As all moments/distances are decreased in the same ratio. (1) 2

(iv) 3 N moved

QoWC (1) (1)

(As distance increased) the moment of  $3 \text{ N}$  (about pivot) increased or (total) clockwise moment is increased. (1)

The moment of  $T$  is increased or anticlockwise moment must increase (to keep clockwise and anticlockwise moments equal). (1)

Magnitude of  $T$  increases. (1)

[Do not accept  $\uparrow$  for increases] 4

[exclusively calculations 0/4] (1)

**[12]**

**186. (i) Work done**

Use of work done = force  $\times$  distance (1)

Answer given to at least 3 sig fig. [2396 J, 2393 J if  $9.8 \text{ m s}^{-2}$  is used, (1) 2

2442 J if  $g = 10 \text{ m s}^{-2}$  is used. No ue.]

$$\begin{aligned} \text{Work done} &= 110 \text{ kg} \times 9.81 \text{ m s}^{-2} \times 2.22 \text{ m} \\ &= 2395.6 \text{ J} \end{aligned}$$

(ii) Power exerted

Use of power =  $\frac{\text{work done}}{\text{time}}$  or power =  $F \times v$  (1)

Answer: [799 W. 800 W if 2400 J is used and 814 W if 2442 J is used. Ecf value from (i)] (1) 2

$$\begin{aligned} \text{Power} &= \frac{2396 \text{ J}}{3 \text{ s}} \\ &= 798.6 \text{ W} \end{aligned}$$

(iii) Principle of Conservation of Energy

Either

Energy can neither be created nor destroyed (1) (1)

**OR**

Energy cannot be created/destroyed or total energy is not lost/gained (1)  
(merely) transformed from one form to another or in a closed/isolated system. (1)

2

[Simple statement 'Energy is conserved' gets no marks]

[Information that is not contradictory ignore.  $\Delta Q = \Delta U + \Delta W$ , with terms defined acceptable for 1st mark]

(iv) How principle applied to...

Lifting the bar: -

Chemical energy (in the body of the weightlifter) or work done  
(lifting bar) = (gain in) g.p.e. (of bar) (1)

[Reference to k.e. is acceptable]

The bar falling: -

Transfer from g.p.e. to k.e. (1)

(and that) g.p.e. lost = k.e. gained (1)

3

['g.p.e. converted to k.e.' would get one mark]

[References to sound and thermal energy are OK, but gpe to sound or thermal energy on its own gets no marks]

(v) Speed of bar on reaching the floor

Setting  $\frac{1}{2}mv^2 = mgh$  or  $\frac{1}{2}mv^2 = \text{work done}$  or 2400 J (1)

[ecf their value]

[Shown as formulae without substitution or as numbers substituted into formulae]

Correct values substituted (1)

[allow this mark if the 110 kg omitted – substitution gives  $v^2 =$  (1)  
 $43.55(6) \text{ m}^2 \text{ s}^{-2}$  or  $44.4 \text{ m}^2 \text{ s}^{-2}$  if  $g = 10 \text{ m s}^{-2}$  is used]

Answer: [6.6 m s<sup>-1</sup>. 6.7 m s<sup>-1</sup> if  $g = 10 \text{ m s}^{-2}$  is used.]

$\frac{1}{2} 110 \text{ kg} \times v^2 = 110 \text{ kg} \times 9.81 \text{ m s}^{-2} \times 2.22 \text{ m}$  or = 2400 J / 2396 J

$v = 6.6 \text{ m s}^{-1}$  [6.66 m s<sup>-1</sup> if  $10 \text{ m s}^{-2}$  used] (1)

**OR**

Selects  $v^2 = u^2 + 2as$  or selects 2 relevant equations (1)

Correct substitution into equation (1)

Answer [6.6 m s<sup>-1</sup>] (1)

$v^2 = 0. + 2 \times 9.81 \text{ ms}^{-2} \times 2.22\text{m}$

$v = 6.6 \text{ m s}^{-1}$

3

[12]

187. (i) Plot a graph

Check any 2 points.

[Award if these correctly plotted in appropriate square] (1)

Curve of best fit. (1)

2

- (ii) Half life average time required (1)  
for the count rate / activity / intensity to reach half the original value or time taken for half of the atoms / nuclei/nuclides to decay (1)  
[NOT mass / particles / atom / (radio)isotope / count / sample/ cells/ nuclide]
- (iii) Use the graph  
Value of half life [Allow answers in the range 3.1 – 3.3. (1)  
Mark not to be awarded if a straight lined graph was plotted]  
Two or more sets of values used to find half life.  
[Could be shown 1 on graph] (1) max 3 (ii &iii)
- (iv) Similar to  
eg (The programme) obeys an exponential law or once a cell has ‘decayed’, it is not available to decay later **or** (the ‘decay’ is) random **or** it is impossible to predict which cell will ‘decay’ next. (1) 1
- (v) Different  
eg (Far) fewer cells available than atoms (in a sample of radioactive material) or it is a different ‘scenario’ eg. they are not atoms but cells on a grid generated by computer. (1) 1

[7]

188. (i) Isotopes  
(Atoms with) same proton number / atomic number  
[not same chemical properties] (1)  
Different numbers of neutrons or different nucleon / mass number  
[not different physical properties / density] (1) 2
- (ii) Unstable isotope of lead  
 $^{212}_{82}\text{Pb}$  (1) 1
- (iii) Table  
All responses correct (3)  
5 responses correct/ 1 wrong (2)  
4 responses correct/ 2 wrong (1)

<i>Decay path</i>	<i>Change of A</i>	<i>Change of Z</i>	<i>Type of decay</i>
	-4/ reduced by 4	-2/ reduced by 2	$\alpha$ / helium nucleus
	0 No change / none	+1	$\beta^-$ / electron [ $\beta$ decay insufficient]

[for change in z, 1 is not sufficient i.e. + is essential] 3

[6]