

Paper 1 (2001)

Time 1 hour

- 1 Which pair contains one vector and one scalar quantity?
- A displacement : acceleration
 B force : kinetic energy
 C momentum : velocity
 D power : speed
- 2 Potential differences may be compared by using a potentiometer, with a galvanometer as an indicator. The potential differences are adjusted until the galvanometer reads zero. This is an example of a null method.

Which statement about null methods is **incorrect**?

- A Null methods are most suitable for the measurement of rapidly varying quantities.
 B Null methods can give only relative, and not absolute, values.
 C The indicator in a null method need not be calibrated.
 D The indicator in a null method need not have a linear response.
- 3 A stone is dropped from the top of a tower of height 40 m. The stone falls from rest and air resistance is negligible.

How long does it take for the stone to fall the last 10 m to the ground?
(Use $g = 10 \text{ m s}^{-2}$.)

- A 0.38 s B 1.48 s C 2.5 s D 2.8 s

- 4 Which graph best shows the variation with time of the momentum of a body accelerated by a constant force?

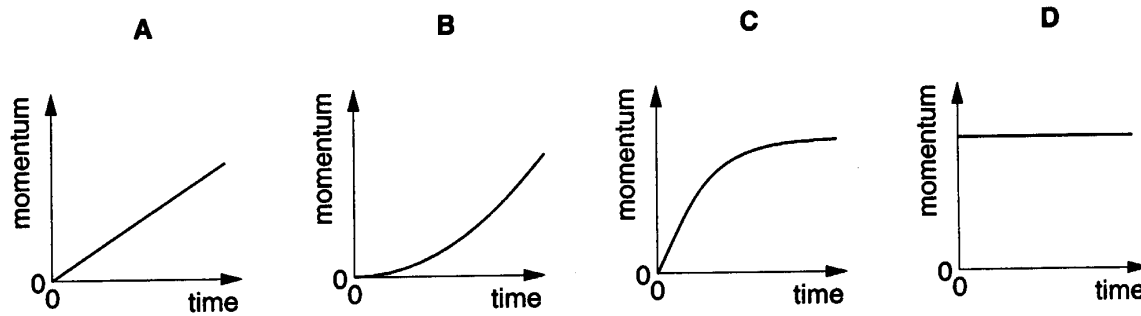

- 5 A uniform plank of weight 60 N is 2000 mm long and rests on a support that is 600 mm from end E. At what distance from E must a 160 N weight be placed in order to balance the plank?

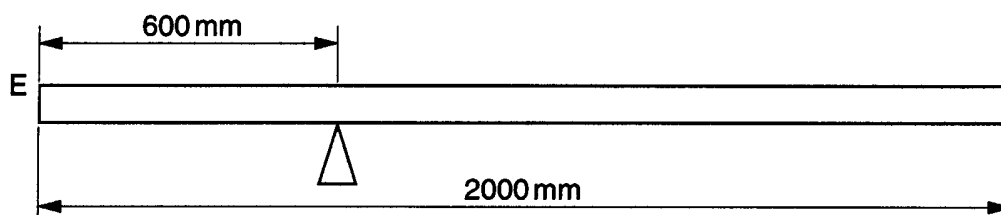

- A 150 mm B 225 mm C 375 mm D 450 mm

- 6 An electrical generator is started at time zero. The total energy transformed by the generator during the first 5 seconds is as shown in the graph.

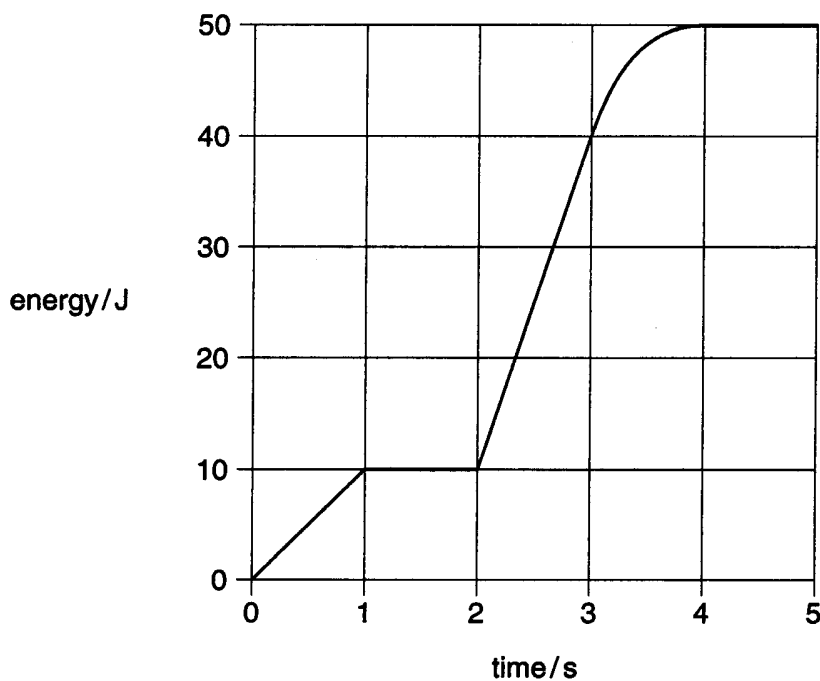

What is the maximum power generated at any instant during these first 5 seconds?

- A 10 W B 13 W C 30 W D 50 W

- 7 On the ground, the gravitational force on a satellite is W .

What is the gravitational force on the satellite when at a height $R/50$, where R is the radius of the Earth?

- A $1.04 W$
 B $1.02 W$
 C $0.98 W$
 D $0.96 W$

- 8 A disc is rotating about an axis through its centre and perpendicular to its plane. A point P on the disc is twice as far from the axis as a point Q .

At a given instant, what is the value of the linear velocity of P divided by the linear velocity of Q ?

- A 4 B 2 C $\frac{1}{2}$ D $\frac{1}{4}$

- 9 A body moves with simple harmonic motion and makes n complete oscillations in one second. What is its angular frequency?

- A $n \text{ rads}^{-1}$ B $\frac{1}{n} \text{ rads}^{-1}$ C $2\pi n \text{ rads}^{-1}$ D $\frac{2\pi}{n} \text{ rads}^{-1}$

- 10 A ray of light is incident on a glass-air boundary for which the critical angle is C . Which diagram correctly shows the paths of the ray?

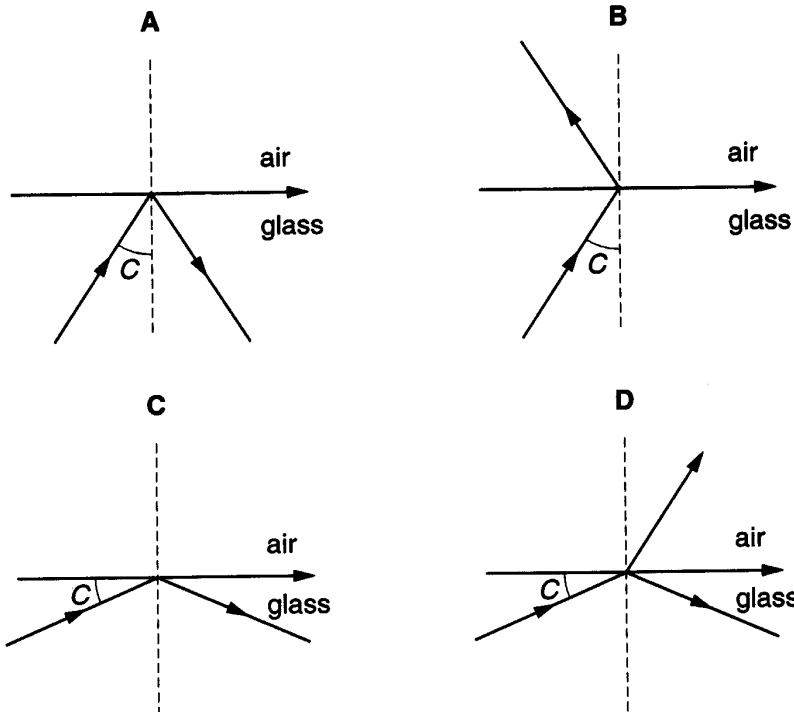

- 11 A plane wave of amplitude A is incident on a surface of area S placed so that it is perpendicular to the direction of travel of the wave. The energy per unit time reaching the surface is E .

The amplitude of the wave is increased to $2A$ and the area of the surface is reduced to $\frac{1}{2}S$.

How much energy per unit time reaches this smaller surface?

- A $4E$ B $2E$ C E D $\frac{1}{2}E$
- 12 Light of wavelength 600 nm falls on a pair of slits, forming fringes 3.0 mm apart on a screen.

What is the fringe spacing when light of wavelength 300 nm is used and the slit separation is halved?

- A 0.75 mm B 1.5 mm C 3.0 mm D 6.0 mm
- 13 Which wavelength lies within the infra-red region of the electromagnetic spectrum?

- A 10^{-3} m B 10^{-6} m C 10^{-9} m D 10^{-12} m

- 14 Four small conductors, on the edge of an insulating disc of radius r ; are each given a charge of Q . The frequency of rotation of the disc is f .

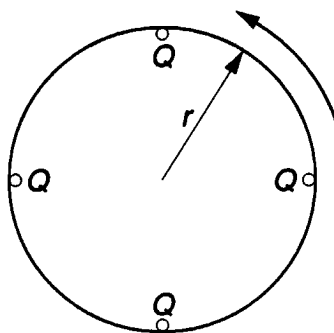

What is the equivalent electric current at the edge of the disc?

- A $4Qf$ B $\frac{4Q}{f}$ C $8\pi rQf$ D $\frac{2Qf}{\pi f}$

- 15 In the circuit shown, there is a current of 3.0 A in the 2.0 Ω resistor.

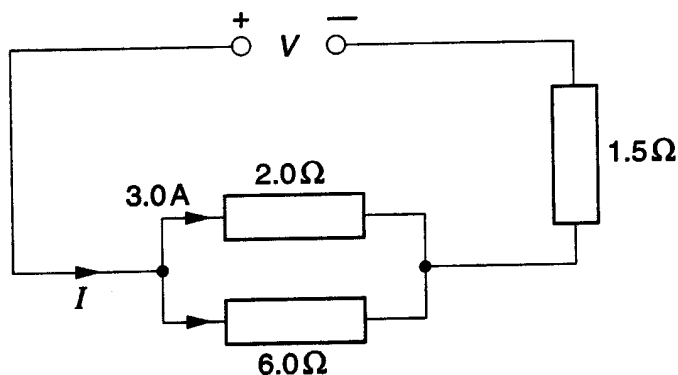

What are the values of the current I delivered by the power supply and the voltage V across it?

	I/A	V/V
A	3.0	10.5
B	4.0	9.0
C	4.0	12
D	12	18

- 16 Two parallel, conducting plates with air between them are placed close to one another. The top plate is given a negative charge and the bottom one is earthed. Which diagram best represents the field and distribution of charges in this situation?

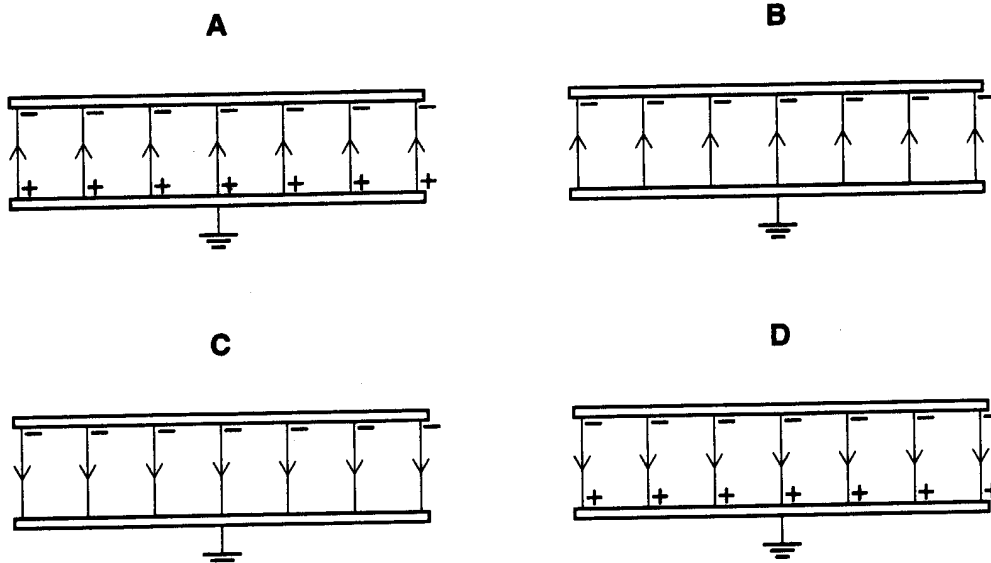

- 17 Two identical capacitors connected in parallel have an effective total capacitance C . The capacitors are then reconnected in series.
What is the capacitance of the series combination?

A $\frac{1}{4}C$ B $\frac{1}{2}C$ C $2C$ D $4C$

- 18 The diagram shows the cross-section of a straight wire that carries a steady current **out of** the plane of the paper towards the observer.
The arrows represent the directions of four magnetic fields, **A**, **B**, **C** and **D**.
Which field causes the wire to move towards the point **X**?

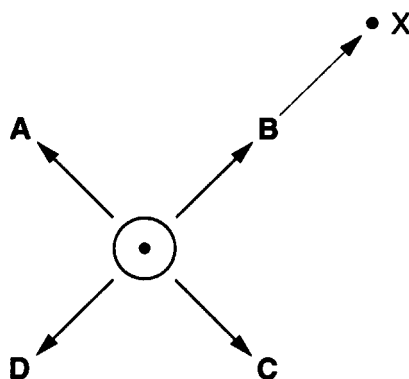

- 19 At the beginning of a horse-race, a horizontal straight wire of length 20 m is raised vertically through a height of 3.0 m in 0.20 s.

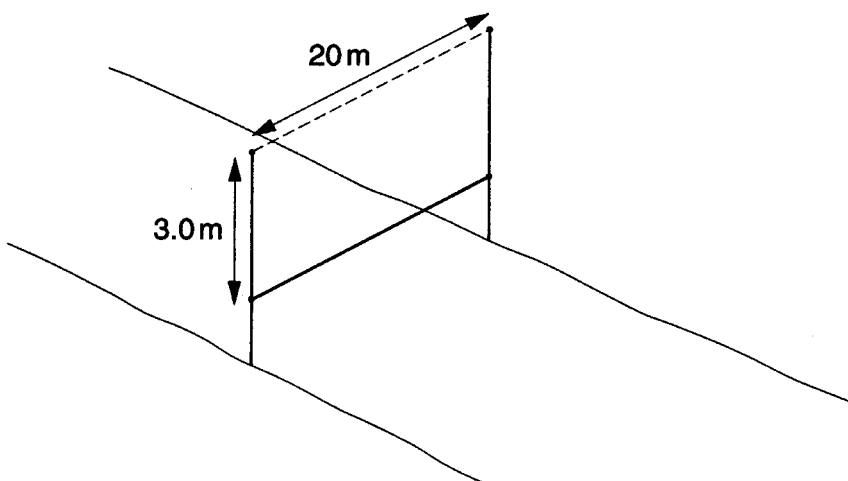

The horizontal component of the Earth's magnetic field strength perpendicular to the wire is 2.0×10^{-5} T.

What is the average e.m.f. induced across the ends of the wire?

A zero B 0.24 mV C 1.2 mV D 6.0 mV

- 20 An ideal, mains-driven transformer supplies power to a load. In order to deliver a current of 2.0 A to the load, the primary coil draws a current of 0.10 A from the 240V mains.

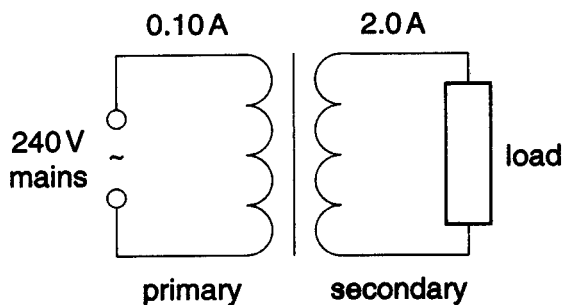

Which set of values in the table is correct?

	number of turns on primary coil	number of turns on secondary coil	p.d. across load/V
A	300	6000	12
B	6000	300	12
C	300	6000	4800
D	6000	300	4800

- 21 An alternating current of root-mean-square value 2 A in a given resistor dissipates energy at the same rate as a steady direct current I in another resistor of the same value. What is the value of I ?

A $\sqrt{2}$ A **B** 2A **C** $2\sqrt{2}$ A **D** 4A

- 22 A sealed U-tube contains nitrogen in one side and helium at pressure P in the other, as shown in the diagram. The gases are separated by mercury of density ρ . The acceleration of free fall is g .

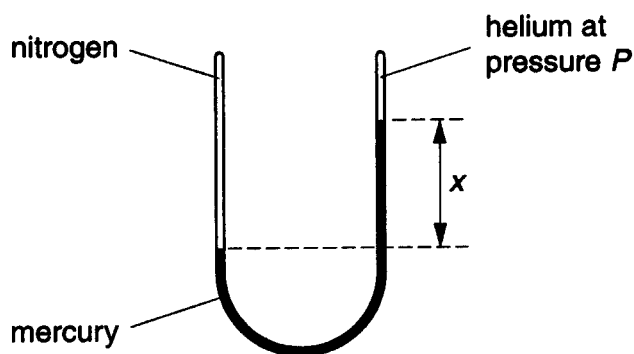

What is the pressure of the nitrogen?

A P **B** $x\rho g$ **C** $P - x\rho g$ **D** $P + x\rho g$

- 23 Cylindrical samples of steel, glass and rubber are each subjected to a gradually increasing tensile force F . The extensions e are measured and graphs are plotted as shown below.

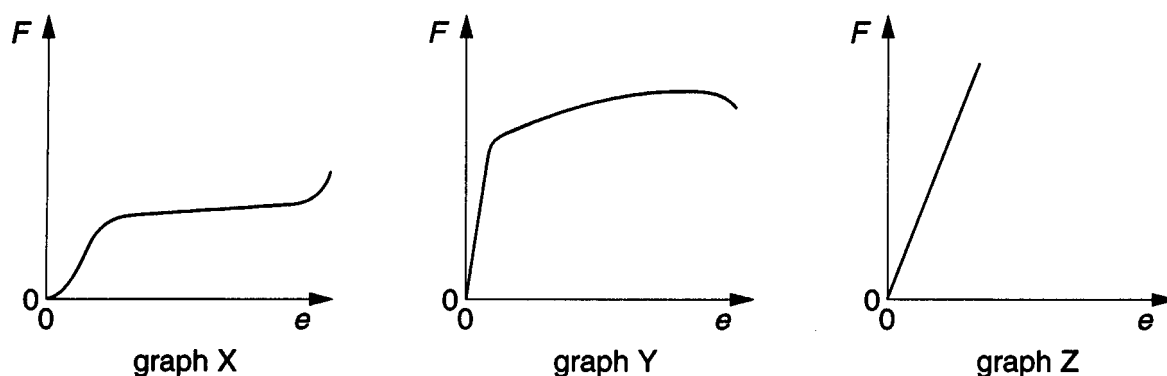

Which row of the following table correctly relates the graphs to the materials?

	steel	glass	rubber
A	X	Y	Z
B	X	Z	Y
C	Y	X	Z
D	Y	Z	X

- 24 A thermocouple is placed with its junctions X and Y in

- (i) melting ice and boiling water, and
- (ii) liquids at temperatures 50°C and θ .

In (i) the voltmeter V reads $+5.0\text{ mV}$, and
in (ii) the voltmeter V reads -1.5 mV .

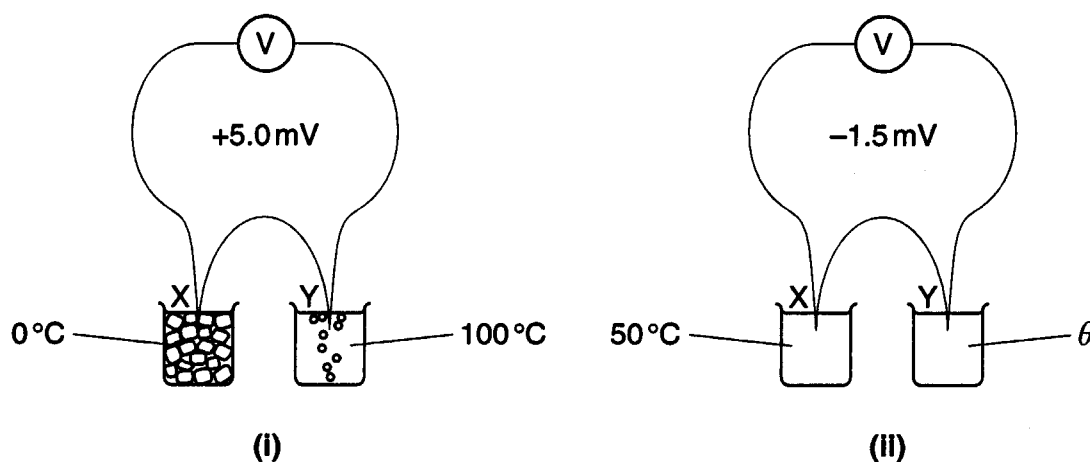

Assuming that the thermocouple has a linear response, what is the temperature θ ?

- A** 20°C **B** 30°C **C** 70°C **D** 80°C

25 What is the approximate number of atoms in a cubic metre of an ideal monatomic gas at a temperature of 27°C and a pressure of $1 \times 10^5 \text{ Pa}$?

- A 1×10^{22} B 6×10^{23} C 2×10^{25} D 3×10^{26}

26 Which quantity must be the same for two bodies if they are to be in thermal equilibrium?

- A internal energy
 B potential energy
 C temperature
 D mass

27 The diagram shows a velocity selector for charged particles.

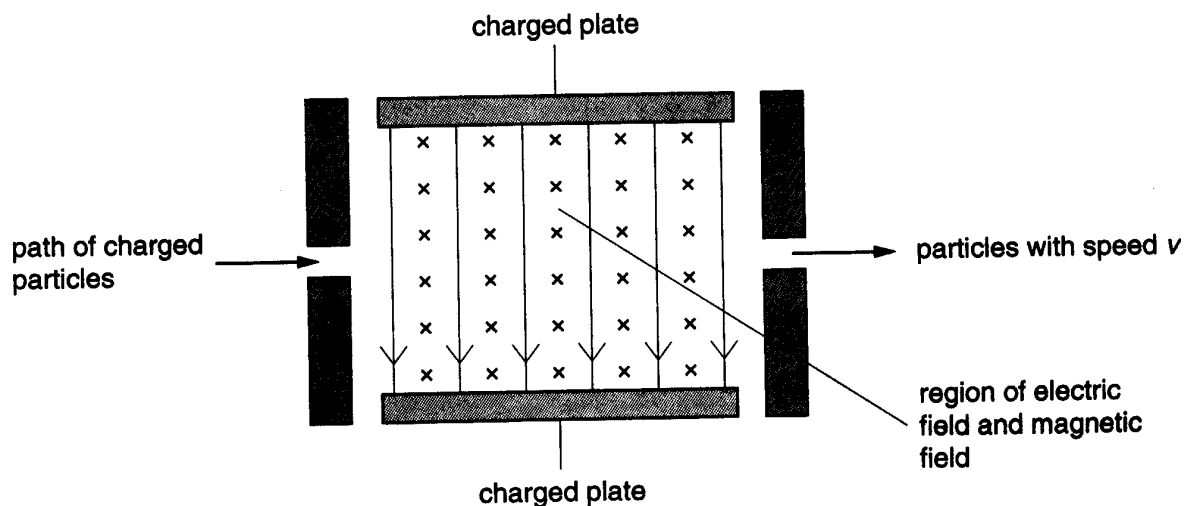

The charged plates give a uniform electric field of strength E . In the same region, there is a uniform magnetic field of flux density B , at right angles to the electric field.

Particles carrying charge Q and having speed v pass through undeviated, because the forces on them due to the electric and magnetic fields are equal in magnitude but opposite in direction.

What is the speed V of particles leaving the selector?

- A $\frac{B}{E}$ B $\frac{E}{B}$ C $\frac{BQ}{E}$ D $\frac{EQ}{B}$

- 28 The scale drawing shows five energy levels of an atom. Five possible transitions between the levels are indicated. Each transition produces a photon of definite energy and frequency.

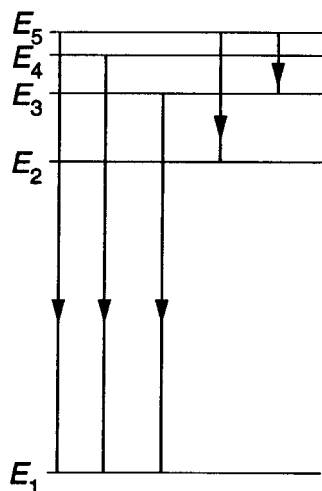

Which spectrum corresponds most closely to the transitions shown?

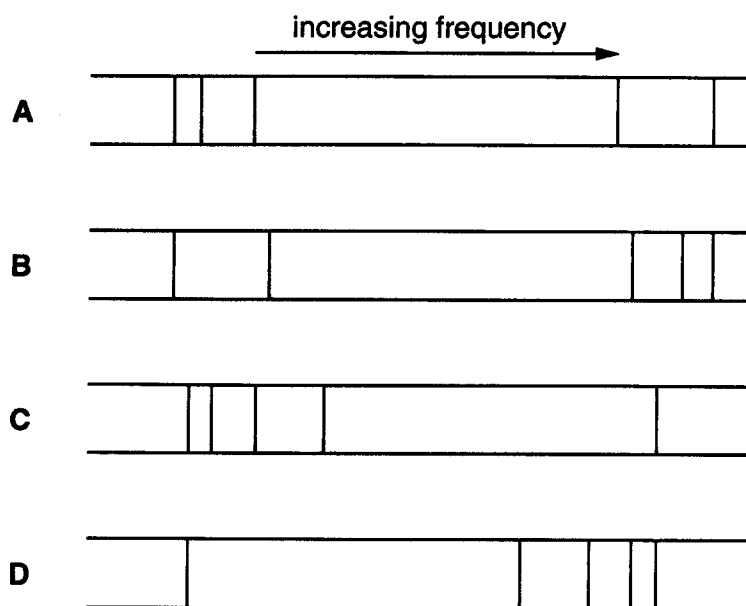

- 29 Which conclusion can be drawn from the results of the experiment showing the scattering of α -particles by gold foil?
- A Electrons orbit the atomic nucleus in well-defined paths.
 - B Nuclei of different isotopes contain different numbers of neutrons.
 - C The atomic nucleus contains protons and neutrons.
 - D The nucleus is very small compared with the size of the atom.

- 30** What is the decay constant of a radioactive substance?
- A** the constant of proportionality in the equation relating the rate of decay of the substance to the number of undecayed nuclei
 - B** the number of disintegrations of the substance occurring in one half-life of the substance
 - C** the number of disintegrations of the substance occurring per second
 - D** the average time taken for half the nuclei initially present in the substance to decay

Paper 2 (2001)

Time 1 hour 45 minutes

- 1 (a)** Explain what is meant by the three terms *conduction*, *convection* and *radiation* when applied to the transfer of thermal energy.

conduction.....

.....

.....

.....

convection.....

.....

.....

.....

.....

radiation.....

.....

.....

.....

.....

- (b)** A heater filament in a hair drier uses energy at a rate of 1000W. When in normal use the temperature of the heater coil is 900 K. As a result of an air stream being blown past the heater coil, 850W is dissipated by forced convection. [7]

- (i)** State how the other 150W is lost from the heater coil when the hair drier is in normal use.

..... [1]

- (ii)** Suggest how the heater coil temperature and the amount of forced convection would alter if the air inlet were to become partially blocked. Give reasons for your answers.

.....

.....

.....

..... [3]

- 2 (a) State the two conditions necessary for a body to be in equilibrium.

.....

 [2]

- (b) A cylinder of mass 160 kg is at rest on a slope which is at 25° to the horizontal. A rope wrapped round the cylinder prevents it from moving, as shown in Fig.2.1. All the forces acting on the object are shown on Fig.2.1 and in a force diagram, Fig.2.2.

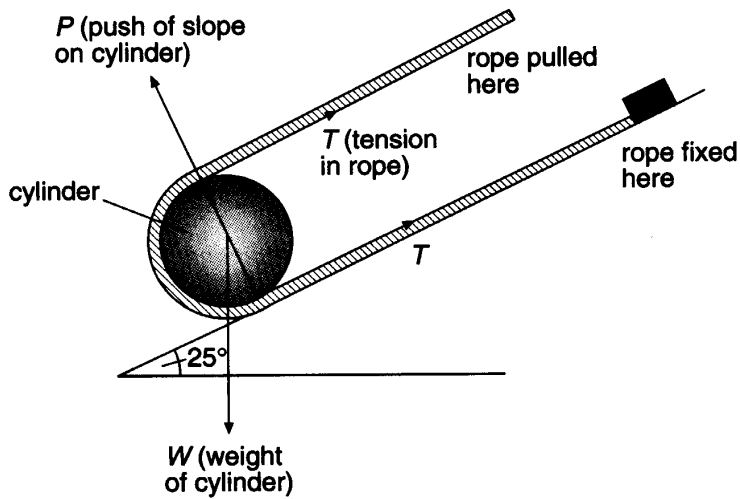

Fig. 2.1

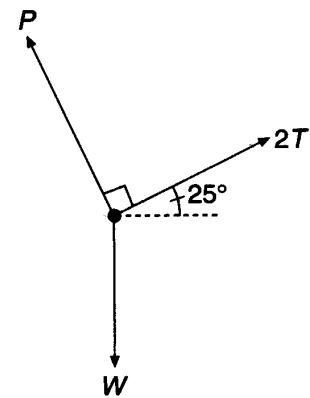

Fig. 2.2

- (i) Calculate the weight of the cylinder.

weight =

- (ii) Draw a vector triangle to scale and use it to calculate the value of the tension T in the rope. State the scale you use.

scale: 1 cm representsN

tension =N
[5]

- (c) The device in (b) is sometimes used for rolling a barrel up a slope out of a cellar. Assuming friction to be negligible, calculate the work done in moving a barrel of mass 160 kg through a distance of 3.0 m up this 25° slope.

work =J [2]

- 3 (a) An object travelling at a constant speed in a circular path is said to have a centripetal acceleration. Explain, using a diagram,
- (i) why there is an acceleration even though the speed is constant,
 - (ii) the direction of the acceleration.
- [4]**

.....

.....

.....

.....

.....

.....

.....

.....

.....

.....

.....

.....

.....

.....

.....

.....

.....

.....

.....

.....

.....

.....

.....

- (b) A motorway designer plans to have motorists leaving one motorway and joining another by constructing a circular link road, as shown in Fig. 3.1.

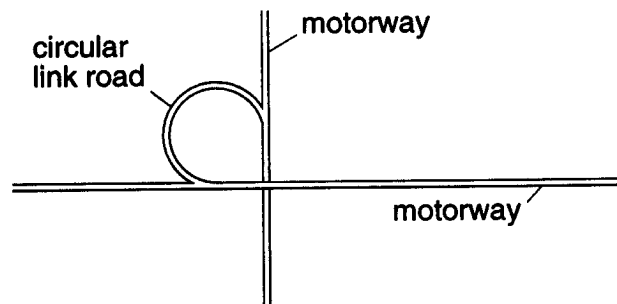

Fig. 3.1

In order to use as small an area of land as possible, the designer proposes a speed limit of 25 ms^{-1} for cars on the circular link road.

- (i) Calculate the minimum radius for the circular link road, given that the maximum sideways force between a car and the road is $0.80 W$, where W is the weight of a car.

radius = m.....[3]

- (ii) Suggest why lorries may have to go at a slower speed than the 25 m s^{-1} limit for cars.

.....
.....
..... [2]

- 4 (a) The variation with time of the displacement of a body is sinusoidal and is shown in Fig. 4.1. The amplitude of the motion is A .

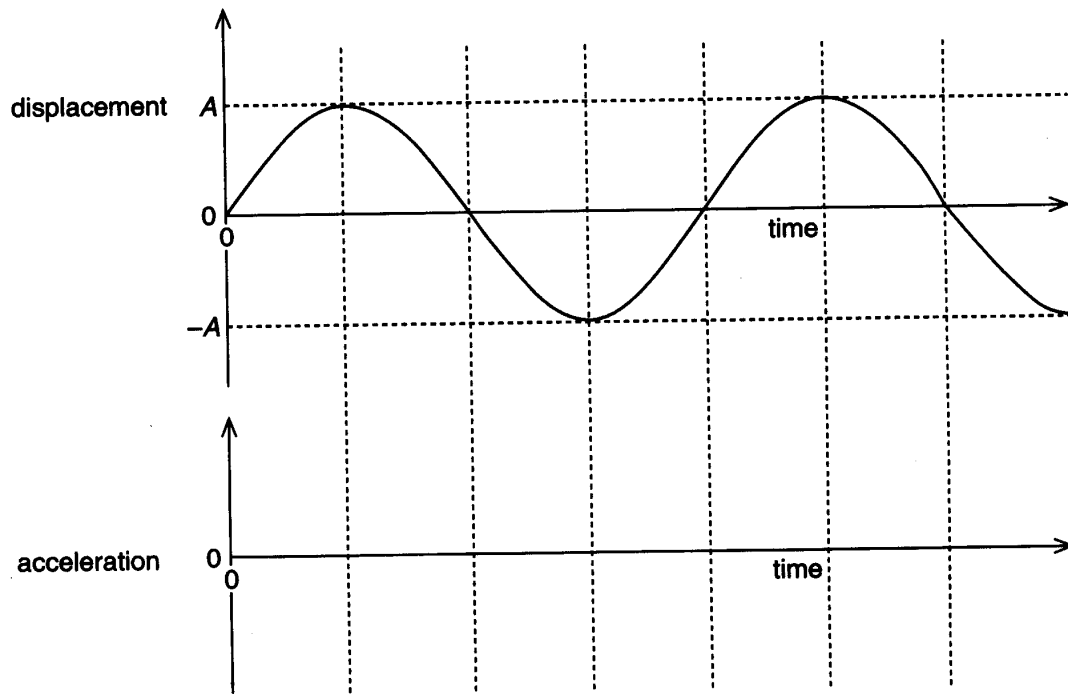

Fig. 4.1

- (i) On the lower set of axes on Fig. 4.1, draw a line to show how the acceleration of the body varies with time. [2]
- (ii) On Fig. 4.2, show how the velocity of the body varies with its displacement. [3]

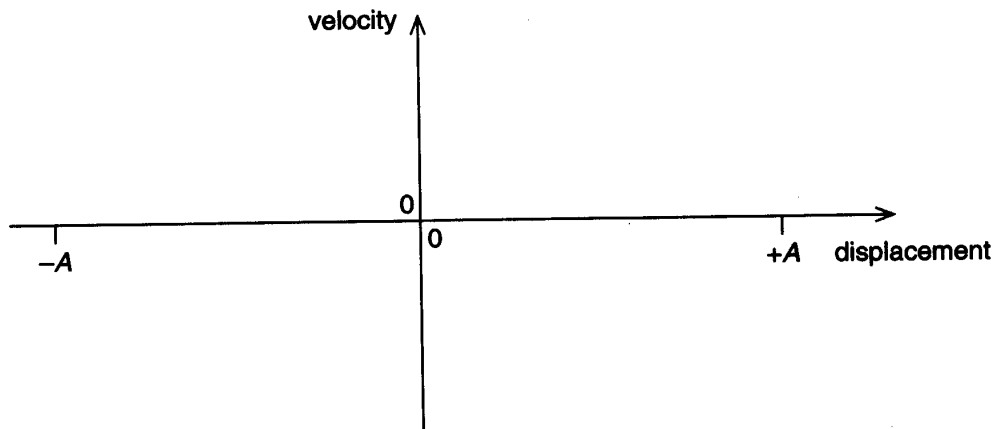

Fig. 4.2

(b) (i) Explain what is meant by *resonance*.

.....
.....
.....
.....
.....
..... [2]

(ii) A washing machine has a drum which can rotate at high speed. Suggest why a concrete block, fixed in the base of the machine, helps to reduce the possibility of resonance.

.....
.....
.....
..... [2]

- 5 Fig.5.1 shows a linear variable resistor of resistance $500\ \Omega$ in use as a potential divider to supply a variable potential difference across a circuit.

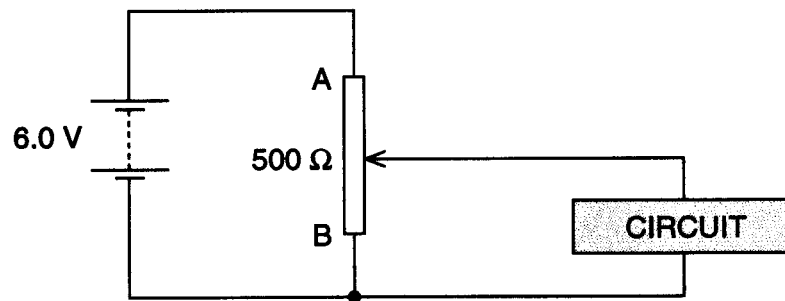

Fig. 5.1

- (a) Determine the potential difference across the circuit when the slider is

(i) at A,

potential difference with slider at A =V

(ii) at B.

potential difference with slider at B =V
[2]

- (b) The circuit has resistance $250\ \Omega$. Calculate the potential difference across the circuit when the slider is half-way between A and B.

potential difference with slider at half-way position =V [3]

- (c) On Fig. 512, sketch how the potential difference across the circuit varies as the slider is moved from A to B. [2]

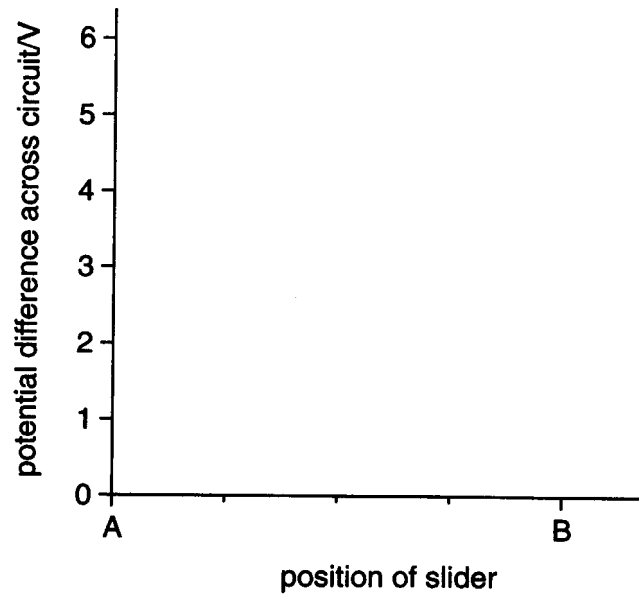

Fig. 5.2

7 (a) Describe the phenomenon *electromagnetic* induction.

.....
.....
.....
.....
..... [2]

(b) State Lenz's law and explain how it is directly related to the law of conservation of energy.

.....
.....
.....
.....
..... [2]

(c) Electromagnetic induction necessitates that switches designed to turn off a direct current are large and complex. Suggest why this is so.

.....
.....
.....
.....
..... [3]

8 (a) Calculate the energy of a photon of ultra-violet radiation of wavelength 250 nm.

energy =J [2]

(b) The work function energy of magnesium is 4.5×10^{-19} J.

(i) Calculate the maximum kinetic energy of photoelectrons from magnesium when illuminated with ultra-violet radiation of wavelength 250 nm.

kinetic energy =J [2]

(ii) Suggest why not all photoelectrons have this maximum energy.

.....
.....
..... [1]

(iii) Suggest how the maximum possible energy of photoelectrons could be determined.

.....
.....
.....
.....
.....
..... [3]

9 In a Swiss railway station, the timetable for trains running between towns is given in the form of a distance-time graph. A modified part of the graph for the times between 0800 hrs and noon is shown in Fig. 9.1. Trains run between town **A** and town **H** with six intermediate stations. Use the graph to answer the following questions.

(a) For complete journeys between **A** and **H** shown in Fig. 9.1, identify the trains which do not stop at intermediate stations.

..... [1]

(b) Draw up a conventional time-table for train **U**.

Station **H** departure time

Station arrival time

departure time

Station **A** arrival time

[2]

(c) Calculate the average speed of train **U** over its entire journey.

average speed = [2]

(d) (i) State the two stations between which train **U** is moving at the maximum speed.

.....

(ii) Calculate the maximum speed.

maximum speed = km h⁻¹
[3]

(e) Suggest why all trains from **D** to **E** go slowly but trains from **E** to **D** go quickly.

.....
..... [1]

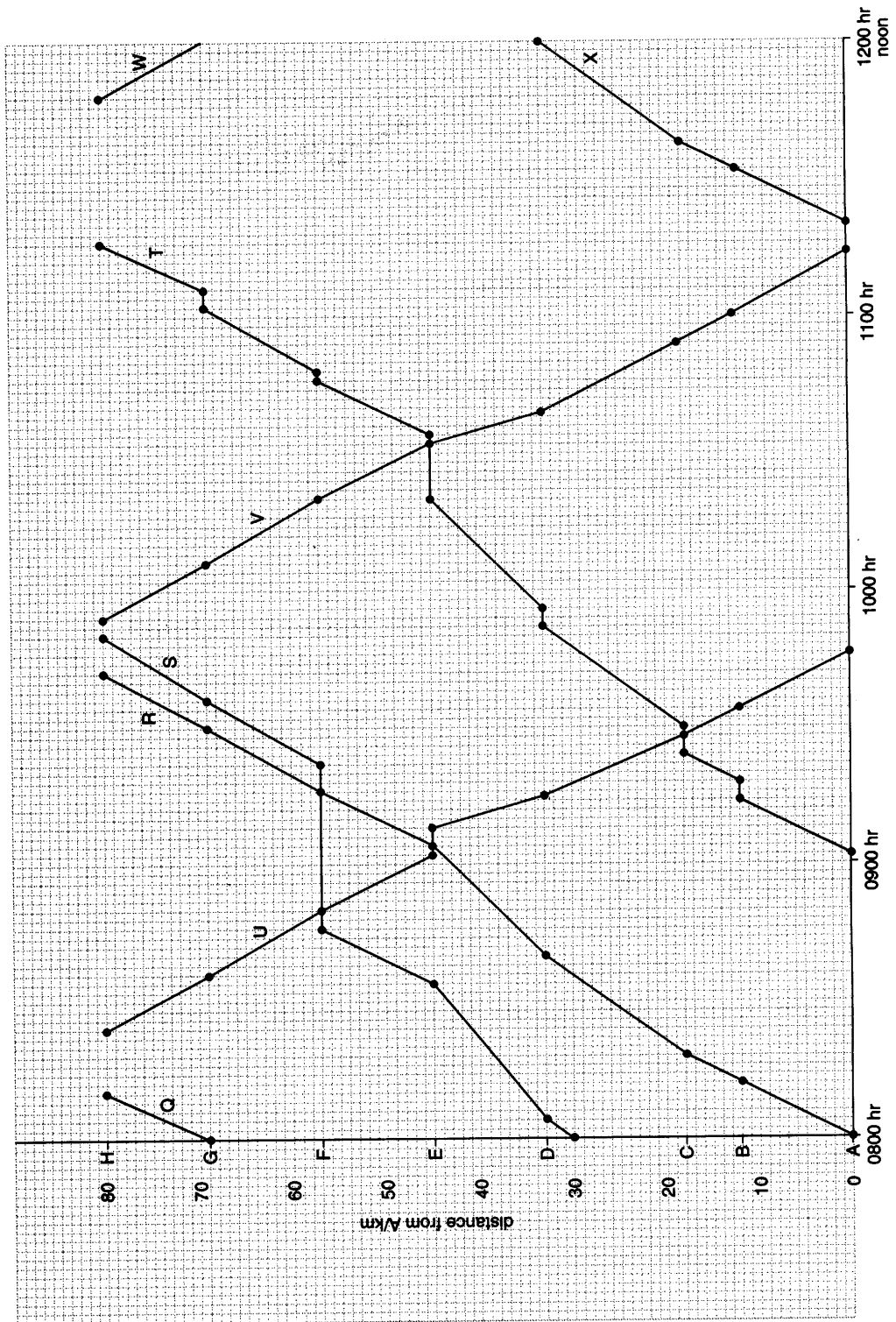

Fig. 9.1

- (f) The altitude of the track alters between **A** and **H**.
- (i) Suggest, stating any assumptions you make, which parts of the track are flat and which parts have an upward gradient.

.....

.....

.....

.....

- (ii) On Fig. 9.2 make a sketch showing your conclusions. [6]



Fig. 9.2

- (g) In fact, trains cannot follow the graphs in Fig. 9.1 exactly. State one respect in which the journeys are idealised in relation to

- (i) speed,

.....

.....

- (ii) acceleration.

.....

.....

[2]

- (h) Trains are travelling on a single track and can pass one another only in stations. Add a line to Fig. 9.1 for an additional train from **A** to **H**. [3]

Paper 3 (2001)

Time 2 hours 30 minutes

Section A

Answer **four** questions from this section.

- 1 (a) Define *linear* momentum. [1]
- (b) Two spheres of masses m_1 and m_2 are moving towards one another along the same straight line.

The spheres have velocities u_1 and u_2 , as illustrated in Fig. 1.1.

Fig. 1.1

During impact, the spheres stick together and then move off with velocity V , as illustrated in Fig. 1.2.

Fig. 1.2

- (i) State and explain whether the collision is elastic or inelastic.
- (ii) Taking the direction of the final velocity V as being positive, write down equations, in terms of m_1 , m_2 , u_1 , u_2 and V , to represent the change in momentum of
1. the sphere of mass m_1 ,
 2. the sphere of mass m_2 .
- (iii) Using your answers to (ii), write down, for this collision, an equation to represent conservation of linear momentum. [6]

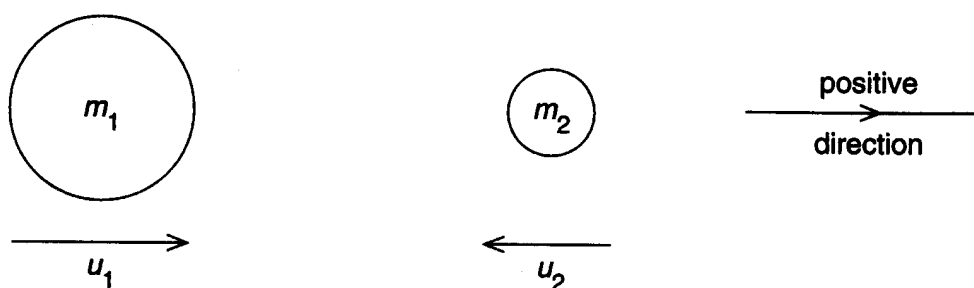
- (c) An ideal gas is enclosed in an insulated cylinder by means of a piston, as illustrated in Fig. 1.3.

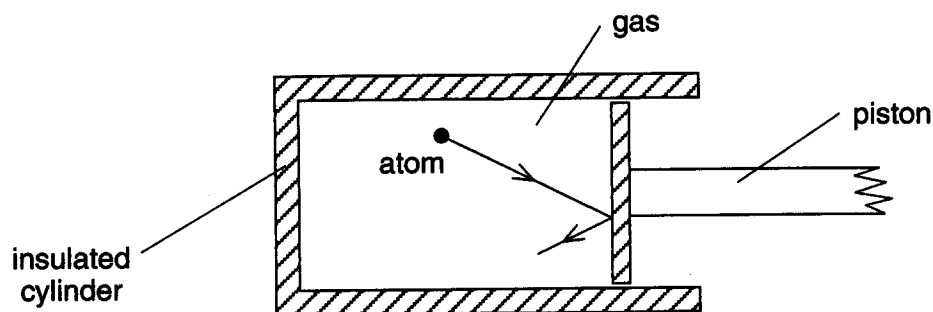

Fig. 1.3

An atom of the gas collides with the stationary piston.

- (i) 1. State the assumption made in the kinetic theory of gases about the nature of the collisions between gas atoms and the walls of the container.
2. State, with a reason, whether the momentum of the atom is conserved in the collision between the atom and the piston.
- (ii) The piston is now moved outwards rapidly so that the gas expands.
1. Suggest what happens to the speed of the atom as a result of a collision with this moving piston.
2. State and explain, in terms of kinetic theory, the change, if any, that your suggestion makes to the temperature of the gas. [7]
- (d) (i) Write down an equation to represent the first law of thermodynamics. Explain carefully the symbols used.
- (ii) Use the first law of thermodynamics to explain your conclusion in (c)(ii) 2. [6]

- 2 (a) (i) Define
1. electric field strength,
 2. electric potential.
- (ii) State how electric field strength at a point may be determined from a graph of the variation of electric potential with distance from the point. [6]
- (b) The moon Charon (discovered in 1978) orbits the planet Pluto. Fig. 2.1 shows the variation of the gravitational potential Φ with distance d above the surface of Pluto along a line joining the centres of Pluto and Charon.

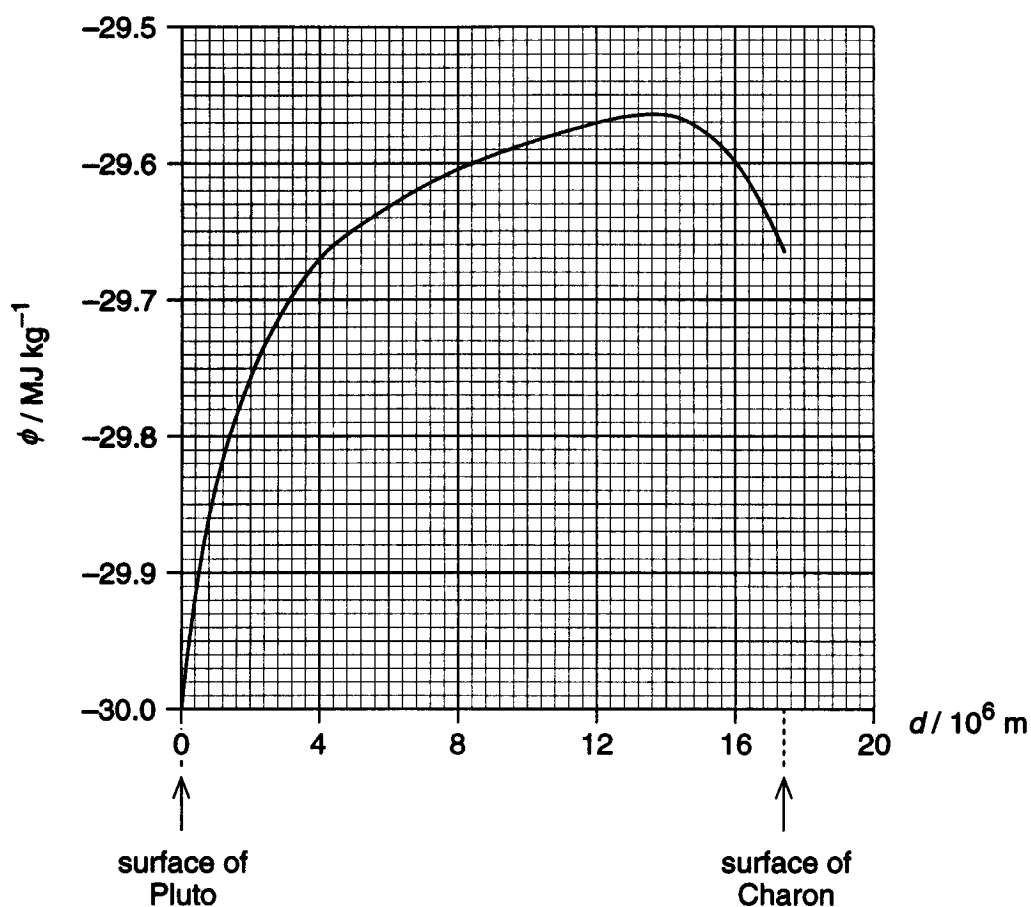

Fig. 2.1

The gravitational potential is taken as being zero at infinity.

- (i) Suggest why all values of gravitational potential are negative. [2]
- (ii) By reference to your answer to (a)(ii), suggest why the gradient at a point on the graph of Fig. 2.1 gives the magnitude of the acceleration of free fall at that point. [2]
- (iii) Use Fig. 2.1 to determine, giving an explanation of your working,
1. the distance from the surface of Pluto at which the acceleration of free fall is zero,
 2. the acceleration of free fall on the surface of Charon. [5]

- (c) A lump of rock of mass 2.5 kg is ejected from the surface of Charon such that it travels towards Pluto.
- (i) Using data from Fig. 2.1, determine the minimum speed with which the rock hits the surface of Pluto.
 - (ii) Suggest why, if the rock travels from Pluto to Charon, the minimum speed on reaching Charon is different from that calculated in (i). [5]

- 3 (a) (i) Describe the motion of one particle in a transverse progressive wave. [2]
- (ii) Sketch suitable graphs, with labelled axes, for a sinusoidal wave to illustrate what is meant by
1. amplitude A ,
 2. wavelength λ ,
 3. period T . [4]
- (iii) Show that the speed v of a wave is related to its frequency f and wavelength λ , by the expression
- $$v = f\lambda. \quad [3]$$
- (b) Explain the *principle of superposition* of two waves. [2]
- (c) Two small sound sources S_1 and S_2 have frequencies 500 Hz and 504 Hz respectively. Sound from the two sources is detected at point X, as illustrated in Fig. 3.1.

• X



Fig. 3.1

The sound waves from S_1 and S_2 have equal amplitudes A at X.

- (i) At time $t = 0$, a wave crest from S_1 meets, at X, a wave crest from S_2 . By reference to your answer to (b), state the resultant amplitude at X.
- (ii) A short time later, a crest from S_1 meets, at X, with a trough from S_2 .
1. Show that crest meets trough at X at time $t = 0.125$ s.
 2. State the resultant amplitude at X at $t = 0.125$ s.
 3. Suggest what would be heard at X during the time interval between $t = 0$ and $t = 1.0$ s. [6]
- (d) (i) Explain the meaning of coherence in relation to the superposition of two waves.
- (ii) Suggest why a variation of resultant amplitude is heard in (c) although the two sources are not coherent. [3]

- 4 (a) Define
- the capacitance of a capacitor,
 - the resistance of a resistor. [2]
- (b) A battery of e.m.f. 6.0 V and negligible internal resistance is connected in series with a capacitor, a resistor and a switch, as shown in Fig. 4.1.

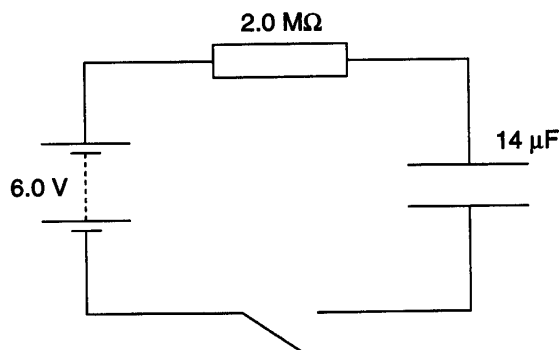

Fig. 4.1

The capacitor has capacitance $14 \mu\text{F}$ and is uncharged initially. The resistor has resistance $2.0 \text{ M}\Omega$.

- The capacitor has infinite resistance to direct current. Explain why, when the switch is closed, there is a current in the resistor.
 - At time t after the switch is closed, the potential differences across the capacitor and across the resistor are V_C and V_R respectively.
 - Use Kirchhoff's laws to write down an equation relating V_C , V_R and the e.m.f. of the battery.
 - Suggest why, as t increases, the p.d. V_C across the capacitor increases, and the current in the circuit changes. [6]
- (c) At one time t , the current in the resistor is $1.8 \times 10^{-6} \text{ A}$.
- Calculate the p.d. V_R across the resistor.
 - Show that the p.d. V_C across the capacitor is 2.4 V.
 - Calculate the charge q on one plate of the capacitor.
 - Calculate the energy E_C stored in the capacitor. [6]
- (d) When the capacitor is fully charged, it is isolated and removed from the circuit. The capacitance of the capacitor is then reduced from $14 \mu\text{F}$ to $5.0 \mu\text{F}$
- Calculate
 - the new p.d. across the capacitor,
 - the energy now stored in the capacitor.
 - The energy stored in the capacitor increases when the capacitance is reduced. Suggest an explanation for this energy increase, making reference to conservation of energy. [6]

- 5 (a) A wire of unextended length l and cross-sectional area A extends elastically by an amount Δl when the tension in the wire is increased by an amount F . Write down expressions in terms of l , Δl , A and F for
- the spring constant k of the wire,
 - the Young modulus E of the material of the wire. [2]
- (b) In order to determine the Young modulus of the metal of a wire, a student set up the apparatus illustrated in Fig. 5.1.

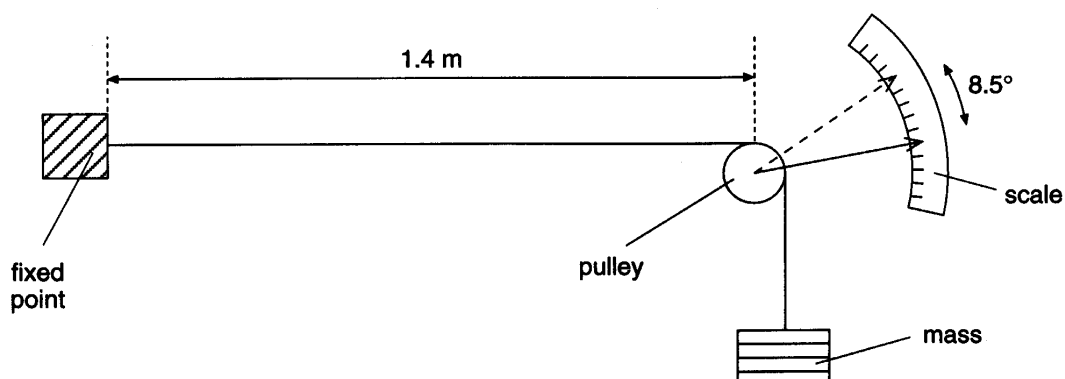

Fig. 5.1

The length of wire between the fixed end and the pulley is 1.4 m and the area of cross-section of the wire is $6.2 \times 10^{-7} \text{ m}^2$. The wire passes over the pulley and is held taut by a mass attached to its free end.

When the mass attached to the end of the wire is increased by 7.0 kg, a pointer attached to the pulley rotates through an angle of 8.5° .

- The pulley has diameter 1.6 cm. The wire does not slip over the pulley as the pulley turns. Show that the extension of the wire resulting from the increased mass on its end is 1.2 mm.
 - Calculate
 - the increase in the stress in the wire,
 - the increase in the strain of the wire,
 - the Young modulus of the material of the wire. [7]
- (c) (i) Sketch a graph to show the variation with load F on the wire of its extension Δl . Assume that the elastic limit is not exceeded.
- (ii) Use your graph to show that the strain energy E_s stored in the wire is given by the expression
- $$E_s = \frac{1}{2} k (\Delta l)^2,$$
- where k is the spring constant of the wire.
- (iii) For a total mass of 8.0 kg attached to the wire, the wire extends by 1.37 mm. Calculate the strain energy stored in the wire for this extension. [6]

- (d) (i) The specific heat capacity of the material of the wire in (b) is $420 \text{ J kg}^{-1} \text{ K}^{-1}$ and the mass of the wire is $6.2 \times 10^{-3} \text{ kg}$. Calculate the change in temperature of the wire when the total mass of 8.0 kg is removed, assuming all the strain energy is converted into thermal energy in the wire.
- (ii) Hence suggest why the steel head of a hammer can become warm when it is used repeatedly to hit nails into wood. [5]

- 6 (a) (i) Distinguish between proton (atomic) number and nucleon (mass) number of a nucleus.
- (ii) Write down the nuclear notation of a nuclide with particular reference to a lithium (Li) nucleus containing 3 protons and 4 neutrons. State the meaning of any number that you write down. [4]
- (b) Free neutrons (neutrons not contained within a nucleus) are unstable and decay by β -emission with a half-life of 770s.
- (i) Explain what is meant by
1. the neutrons are unstable,
 2. half-life. [4]
- (ii) Write down a possible nuclear equation for the decay of a free neutron. [1]
- (iii) Using your relationship in (ii) and the following data, calculate the energy released in the decay of a free neutron.
- rest mass of neutron = 1.008665 u
- rest mass of proton = 1.007276 u
- rest mass of electron = 0.000549 u [3]
- (c) (i) Sketch a graph to show the variation with nucleon number of the binding energy per nucleon of nuclei.
- (ii) By reference to your graph, explain how the process of nuclear fusion may result in the release of energy. [4]
- (d) A 'superheavy' nucleus with 118 protons and 175 neutrons has been discovered. This was achieved by firing very high energy Krypton-86 (${}^{86}_{36}\text{Kr}$) nuclei at a Lead-208 (${}^{208}_{82}\text{Pb}$) target.
- (i) Write down the nuclear equation for this fusion reaction.
- (ii) The 'superheavy' nucleus was identified by the emission of a series of six high-energy α -particles within a short period of time.
- Suggest
1. why the 'superheavy' nucleus decays soon after production,
 2. the nuclear composition (the numbers of protons and of neutrons) of the nucleus into which the 'superheavy' nucleus decays. [4]

Section B

Answer **two** questions from this section.

One question is set on each of the seven optional topics, namely

Question 7	Option A	Astrophysics and Cosmology,
Question 8	Option C	The Physics of Materials,
Question 9	Option E	Electronics,
Question 10	Option F	The Physics of Fluids,
Question 11	Option M	Medical Physics,
Question 12	Option P	Environmental Physics,
Question 13	Option T	Telecommunications.

You may choose any **two** questions.

Option A**Astrophysics and Cosmology**

- 7 (a) Fig. 7.1 gives distances from Earth, or diameters, of objects in the Universe.

<i>distance (or diameter)</i>	<i>identity</i>
4×10^5 km	distance between Earth and Sun
8 light-minutes	
6×10^4 light-years	
1×10^7 light-years	

Copy Fig. 7.1 and complete it by suggesting, in each case, what the distance or diameter might be. **[3]**

- (b) (i) State, in chronological order, the main processes that are thought to have occurred between 0.01s after the big bang and the formation of atoms. **[5]**
- (ii) Outline one difficulty involved in projecting the evolution of the Universe back before about 0.01 s. **[3]**

- (c) Fig. 7.2 shows the relative transparency of the Earth's atmosphere to electromagnetic radiation of various wavelengths.

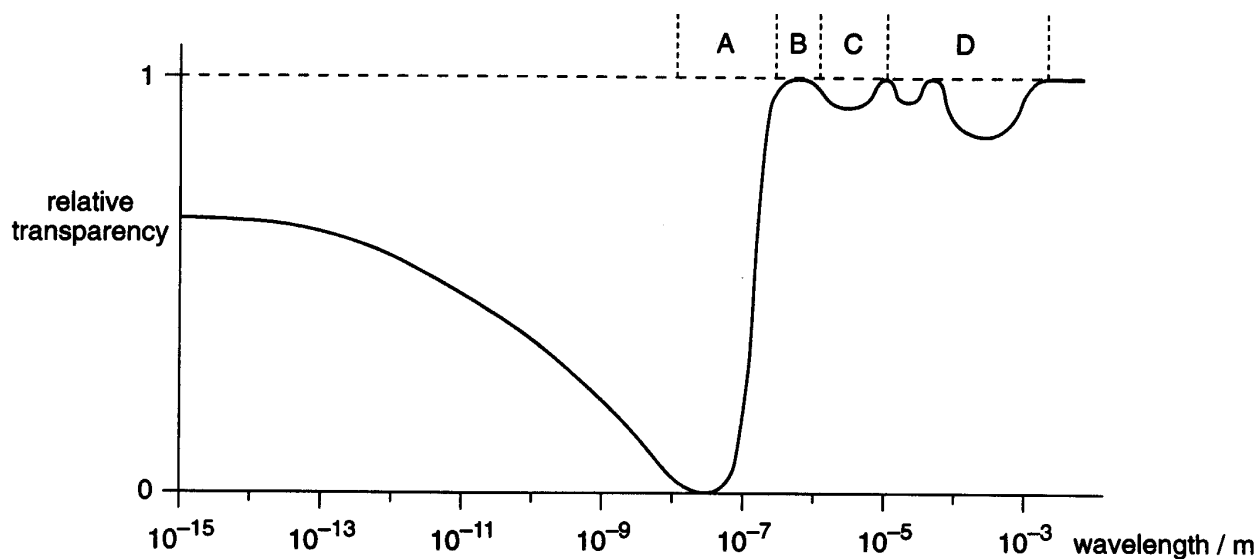

Fig. 7.2

- (i) Identify the region, A, B, C or D, corresponding to visible light.
- (ii) Some astronomical observations are made using electromagnetic radiation of wavelength about 50 nm. By reference to Fig. 7.2, suggest why such observations are made from satellites or space probes.
- (iii) Give two reasons why astronomical telescopes detecting visible light are sometimes sited on isolated mountain-tops. [4]

Option C**The Physics of Materials**

- 8 (a) (i) Draw a diagram to illustrate the lattice structure of a hexagonal crystal.
- (ii) Explain the concept of the Bravais lattice, illustrating your answer by reference to a hexagonal lattice structure. [6]
- (b) (i) Outline an experiment to demonstrate the processes of quenching and tempering of steel.
- (ii) Describe the properties of steel when it has been
1. quenched,
 2. tempered. [5]
- (c) In early designs of steam boilers, some catastrophic accidents happened as a result of creep. Outline the process of creep, and the conditions under which it is likely to occur. [4]

Option E

Electronics

- 9 (a) A student designs a thermometer using a thermistor T . He connects the thermistor in the circuit of Fig. 9.1.

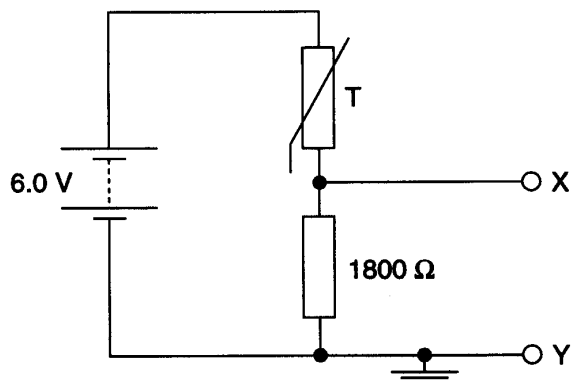

Fig. 9.1

The battery has e.m.f. 6.0 V and negligible internal resistance. The resistance of the thermistor is $1800\ \Omega$ at 20°C and $1500\ \Omega$ at 25°C . Calculate the potential difference across the fixed resistor of resistance $1800\ \Omega$ for thermistor temperatures of

- (i) 20°C ,
(ii) 25°C .

- (b) The student decides to use the circuit of Fig. 9.2 to amplify the change in p.d. due to the change in temperature of the thermistor. [3]

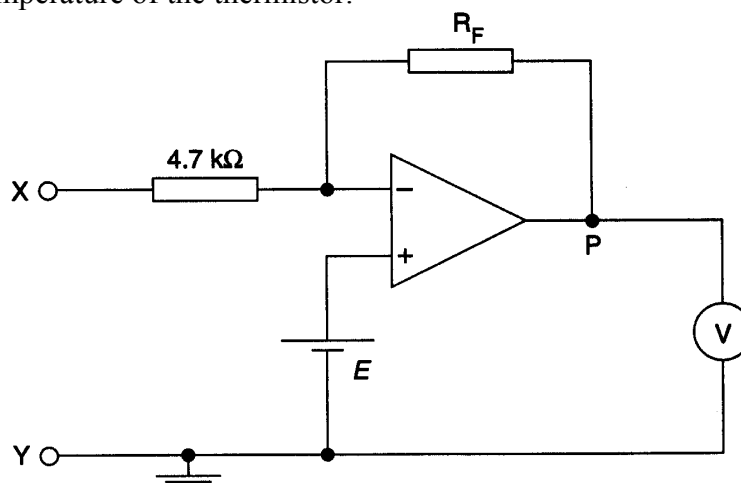

Fig. 9.2

- (i) State which terminal of the voltmeter, the positive or the negative, must be connected to point P so that positive values of voltage are shown on the voltmeter.

- (ii) Deduce, with an explanation, the e.m.f. E of the battery connected between earth and the non-inverting input of the op-amp so that, when the thermistor is at 20°C , the voltmeter reads zero.
- (iii) The magnitude of the gain of the amplifier is to be 30. Deduce a suitable value of resistance for the resistor R_F . [5]

(c) The logic circuit of Fig. 9.3 has been designed to monitor the closing of four doors.

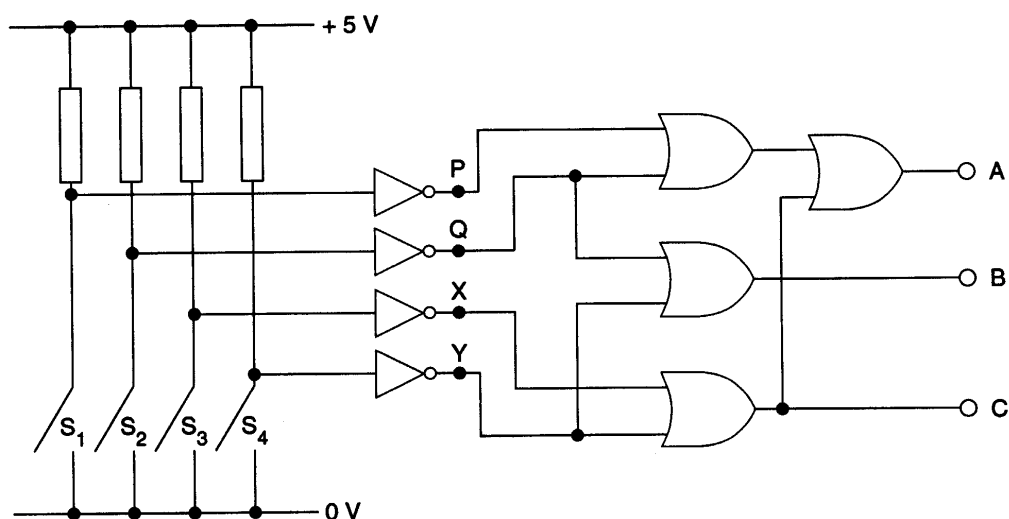

Fig. 9.3

One switch, S_1 , S_2 , S_3 , or S_4 , is connected to each door. When a door is closed, the relevant switch closes. Only one door at any one time may be closed. Logic state 1 is given by $+5\text{ V}$ and logic state 0 is 0 V .

- (i) Write down the logic state
1. at P when S_1 is closed,
 2. at A when any one of the doors is closed.
- (ii) Complete the truth table of Fig. 9.4 for the circuit of Fig. 9.3.

P	Q	X	Y	B	C
1	0	0	0		
0	1	0	0		
0	0	1	0		
0	0	0	1		

- (iii) Hence state which of the outputs A , B and C , are at logic state 1 when S_3 is closed.

[7]

Option F

The Physics of Fluids

10 (a) Draw streamlines to illustrate the flow of liquid round a stationary sphere for

- (i) laminar flow,
- (ii) turbulent flow.

[3]

(b) A small metal sphere has radius r of 1.8 mm and is falling at a constant speed V of 28 mm s^{-1} through a liquid of density 1800 kg m^{-3} . The density of the metal of the sphere is 7700 kg m^{-3} .

- (i) Draw a diagram to show the forces acting on the sphere as it falls through the liquid.
- (ii) Calculate the upthrust on the sphere.
- (iii) The sphere is falling through the liquid under conditions of streamline flow. The drag force F on the sphere is given by

$$F = 6\pi r \eta v,$$

where η is the viscosity, in $\text{kg m}^{-1} \text{ s}^{-1}$, of the liquid.

Calculate the viscosity of the liquid.

[7]

(c) A spinning cricket ball is moving through air as illustrated in Fig. 10.1.

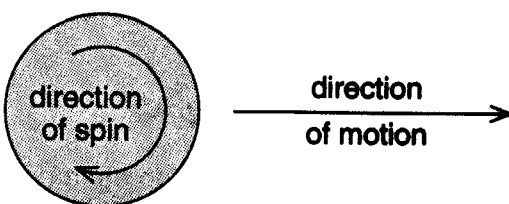

Fig. 10.1

Explain why, and in which direction, the ball is likely to swing.

[5]

Option M

Medical Physics

- 11 (a) (i) Outline the effects of ionising radiation on living matter.
- (ii) In some X-ray equipment, an aluminium filter is placed in the X-ray beam between the tube and patient. Suggest why such a filter may be used. [6]
- (b) (i) A medical laser operates at a beam power of 20 W. The beam is focused by a convex lens to a spot of diameter 0.14 mm. Calculate the intensity of the light in the focused spot.
- (ii) Fig. 11.1 shows the beam incident on three separate layers of skin tissue.

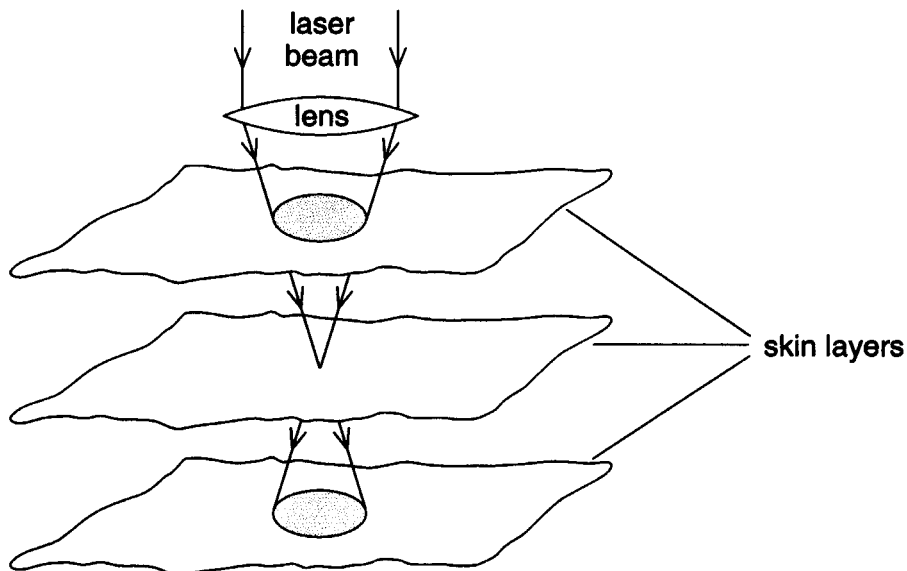

Fig. 11.1

By reference to Fig 11.1, suggest why a laser beam, focused by a lens of short focal length, is likely to be more precise in its effect than one focused using a long focal length lens. [4]

- (c) Fig. 11.2 is a graph, with unscaled axes, of the variation with frequency of intensity of sound at the threshold of hearing for a young person with normal hearing.

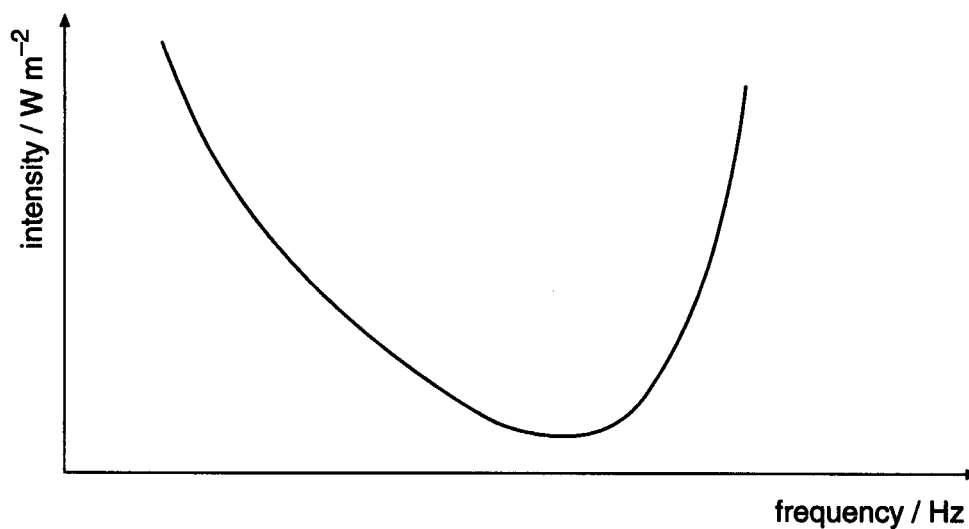

Fig. 11.2

- (i) Copy Fig. 11.2 and on it mark
1. the audible range of frequencies of human hearing,
 2. the frequency at which the ear is most sensitive.
- (ii) A student suggests that the y-axis should be labelled *intensity level*. Comment on whether this change would affect the shape of the graph. [5]

Option P

Environmental Physics

- (a) (i) State what is meant by a fuel.
 (ii) Explain why, although fuel supplies are abundant, alternative energy sources are being developed. [3]
- (b) (i) The trough-to-crest height of waves on water of density ρ is $2A$. The waves have speed v . Show that the average wave power P of waves in a wavefront of length L is given by

$$P = \frac{1}{2} A^2 \rho g v L \quad [4]$$

- (ii) Calculate the average maximum power available from a 20 m long wavefront of waves with a trough-to-crest height of 0.9 m and a speed of 3.0 m s^{-1} .

The density of water is 1000 kg m^{-3} . [2]

- (iii) A wave-powered electricity generator is installed for use by a small community on an island. Suggest two reasons why a back-up diesel generator would be necessary. [2]

- (c) Fig. 12.1 shows a block diagram of a coal-fired generating station.

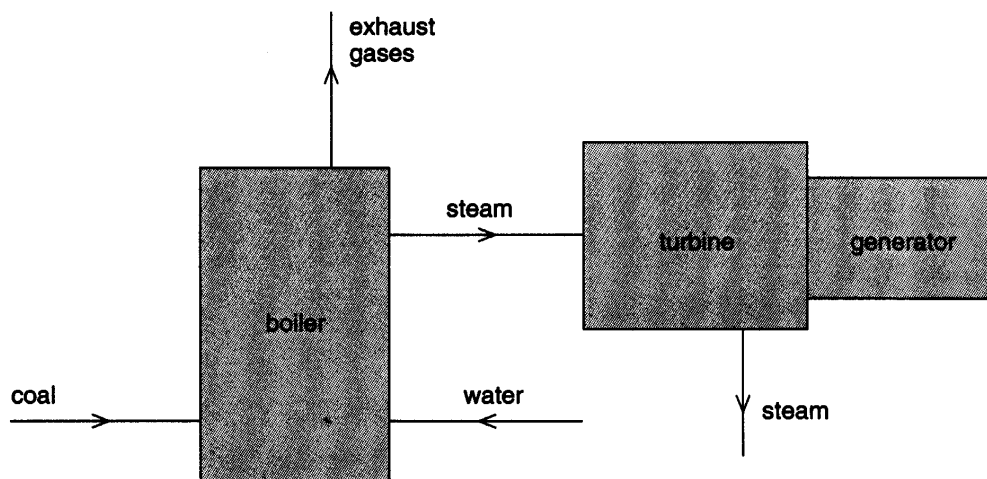

Fig. 12.1

For one particular turbine, steam enters the turbine at 550°C and leaves at 120°C .

- (i) Calculate the maximum efficiency of the turbine.
 (ii) Suggest one way in which thermal energy in the exhaust gases may be used to improve the overall efficiency of the generating station. [4]

Option T**Telecommunications**

- 13 (a) (i)** Explain what is meant by modulation of a wave.
- (ii)** Distinguish between amplitude modulation (AM) and frequency modulation (FM).
- (iii)** For national AM radio broadcasts, the range of audio frequencies transmitted is restricted. Suggest one advantage and one disadvantage of this restriction. **[6]**
- (b)** Two channels of digital communication are optic fibres and metal cables. Giving numerical estimates wherever possible, compare these two channels of communication, making reference to attenuation and noise. **[6]**
- (c)** Suggest why ionospheric reflection as a means of long-distance communication is less reliable than communication via satellites in geostationary orbit. **[3]**

Answers (2001)

Paper 1 Multiple Choice

- | | | |
|-------|-------|-------|
| 1. B | 11. B | 21. B |
| 2. A | 12. C | 22. D |
| 3. A | 13. B | 23. D |
| 4. A | 14. A | 24. A |
| 5. D | 15. C | 25. C |
| 6. C | 16. A | 26. C |
| 7. D | 17. A | 27. B |
| 8. B | 18. C | 28. B |
| 9. C | 19. D | 29. D |
| 10. A | 20. B | 30. A |

Paper 2 (No answers available at this time)

Paper 3 (Numerical answers only)

Section A

Question 2

(b)(iii) 13.7×10^6 m, 0.052 m s^{-2} ; (c)(i) 940 m s^{-1}

Question 4

(c)(i) 3.6 V, (c)(ii) 2.4 V; (c)(iii) 3.4×10^{-5} C; (c)(iv) 4.0×10^{-5} J; (d)(i) 17 V, 7.1×10^{-4} J

Question 5

(b)(ii) 1.1×10^8 Pa, 8.6×10^{-4} , 1.3×10^{11} Pa; (c)(iii) 0.054 J; (d)(i) 0.021 K

Question 6

(b)(iii) 1.3×10^{-13} J

Section B

Question 9

(a)(i) 3.0 V; (a)(ii) 3.27 V; (b)(iii) 140 k Ω

Question 10

(b)(ii) 4.3×10^{-4} N; (b)(iii) $1.5 \text{ kg m}^{-1} \text{ s}^{-1}$

Question 11

(b)(i) $1.3 \times 10^9 \text{ W m}^{-2}$

Question 12

(b)(ii) 59 kW; (c)(i) 52 %