



Rewarding Learning
ADVANCED SUBSIDIARY (AS)
General Certificate of Education
2015

Centre Number

--	--	--	--	--

Candidate Number

--	--	--	--

Physics

Assessment Unit AS 1

assessing

Module 1: Forces, Energy and Electricity

MV18

[AY111]

THURSDAY 11 JUNE, MORNING

TIME

1 hour 30 minutes, plus your additional time allowance.

INSTRUCTIONS TO CANDIDATES

Write your Centre Number and Candidate Number in the spaces provided at the top of this page.

Answer **all ten** questions.

Write your answers in the spaces provided in this question paper.

INFORMATION FOR CANDIDATES

The total mark for this paper is 75.

Quality of written communication will be assessed in Question 3. Figures in brackets printed at the end of each question indicate the marks awarded to each part of the question.

Your attention is drawn to the Data and Formulae Sheet which is inside this question paper.

You may use an electronic calculator.

1 (a) State the Principle of Conservation of Energy. [1 mark]

(b) Define Power. [1 mark]

(c) A tidal barrage uses the ebb and flow of the tides to produce electrical energy. The moving water drives a turbine and ultimately electrical energy is generated. See **Fig. 1.1** below.

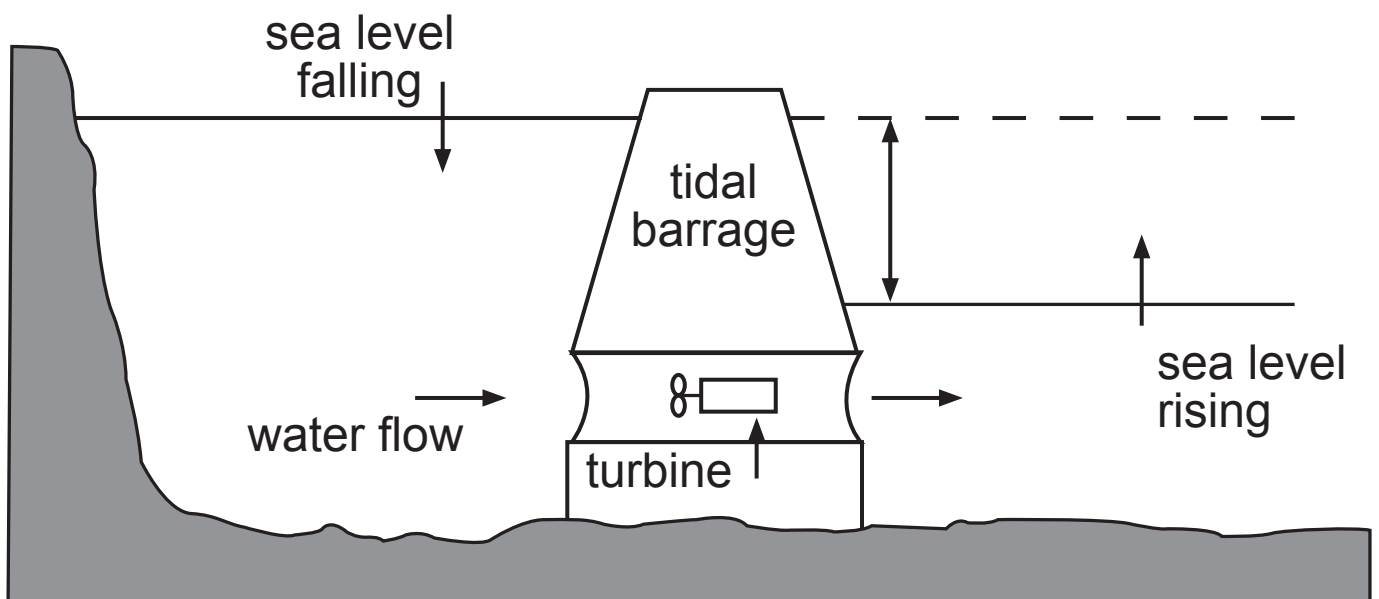

Fig. 1.1

The water falls through a vertical height of 6.0 metres as the tide changes. Calculate the minimum mass of water moving through the turbine every second if the electrical power output from the barrage is 30 MW. Assume no energy losses. [3 marks]

Give your answer to 2 significant figures.

Mass of water/second = _____ kg s^{-1}

2 A new sports car is to be tested on a long, straight, horizontal test track.

(a) The test driver starts the vehicle from rest and accelerates uniformly to a maximum velocity of 200 km h^{-1} in 12.0 seconds. The car continues at this velocity for 20 seconds before the brakes are applied causing constant, rapid deceleration. The car comes to rest in a further 8 seconds.

(i) Show that 200 km h^{-1} is equivalent to 55.6 m s^{-1}
[1 mark]

(ii) On **Fig. 2.1** sketch a velocity–time graph to represent the motion of the car on the track. Include relevant numerical data on both axes. [2 marks]

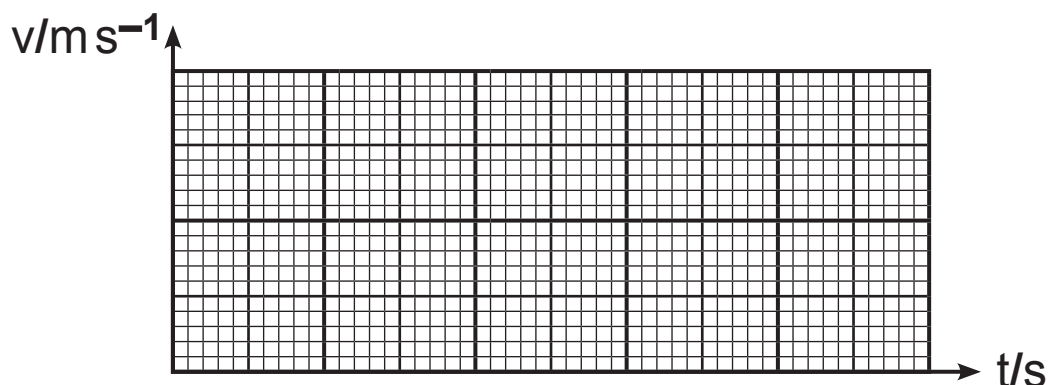

Fig. 2.1

(iii) Use your graph on page 4 to find the total distance the car has travelled during this test run. [2 marks]

Distance travelled = _____ m

(b) (i) State Newton's Second Law of Motion. [2 marks]

The mass of the sports car and driver is 1480 kg. It is now driven along an upward sloping test track inclined at 12° to the horizontal. The driving force F_D from the engine is 8.0 kN and the car accelerates up the slope. The frictional force opposing the motion of the car is 200 N as shown in **Fig. 2.2**.

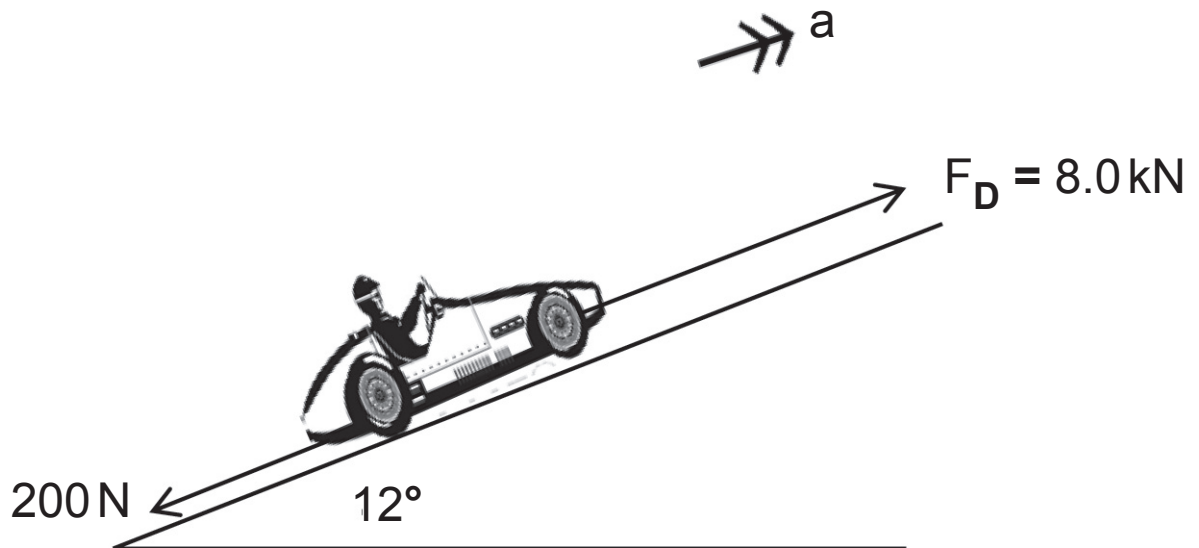

Fig. 2.2

- (ii) Calculate the acceleration of the car up the slope.
[2 marks]

Acceleration = _____ m s^{-2}

- (iii) A second, heavier, car is now tested alongside the sports car. Both cars start from rest at the start of the track and are travelling in the same direction up the slope. The acceleration of the second heavier car is 60% that of the sports car. How long after the start of the test is the separation of the cars 180m? [3 marks]

Time after start of test = _____ s

Where possible in this question you should answer in continuous prose. You will be assessed on the quality of your written communication.

- 3** On the 14th October 2012, sky-diver Felix Baumgartner stepped out from a space capsule approximately 39,000 m above the New Mexico desert in a successful attempt to break the record for the highest and longest free fall. It took him 10 minutes to fall to earth and he was in free fall for just under 5 minutes.

Describe an experiment to determine the acceleration of free fall, g , in a school laboratory.

Your account should include:

- (a)** A labelled diagram of the equipment used.
- (b)** The data required and how that data is obtained.
- (c)** An explanation of how the data could be used to obtain a value for g .
- (d)** How you would improve the reliability of your result.

(a) Diagram [1 mark]

(b) Data required and how that data is obtained. [2 marks]

(c) How that data is used to obtain ***g***. [2 marks]

(d) How would you improve the reliability of your result?
[1 mark]

Quality of written communication [2 marks]

BLANK PAGE

(Questions continue overleaf)

4 The men's long jump at the London 2012 Olympic Games was won by the Great Britain and Northern Ireland athlete Greg Rutherford with a jump of 8.31 m.

(a) Name the type of path that a long jumper will take when airborne. [1 mark]

(b) State the horizontal and vertical velocity components of his initial velocity v if his launch angle was 37° . [1 mark]



Fig. 4.1

Horizontal component _____

Vertical component _____

- (c) (i) Calculate the time for which he was in the air if the magnitude of his take-off velocity v was 9.21 m s^{-1} and his launch angle was still 37° . [2 marks]

Time of flight = _____ s

(ii) Calculate the magnitude and direction of his resultant velocity 0.50 seconds after take-off. [4 marks]

Magnitude of velocity = _____ ms^{-1}

Direction relative to horizontal: _____ $^{\circ}$

5 (a) A student states the principle of moments as:

“When an object moves, the sum of the clockwise moments equals the sum of the anticlockwise moments.”

Identify two errors or omissions in the student’s statement. [2 marks]

1. _____

2. _____

(b) The student attends a gym. He holds a 1.5 kg dumb-bell in his hand and keeps his arm horizontal before lifting the mass upwards. The forearm pivots about the elbow joint and has a weight of 25 N, which acts 19.0 cm from this joint. The force in his bicep F_B acts vertically upwards at a distance of 6.8 cm from the elbow joint. The centre of gravity of the dumb-bell is 37.0 cm from the elbow joint. The vertical force at the elbow joint is labelled F_E . The situation is shown in **Fig. 5.1** below. (Not to scale).

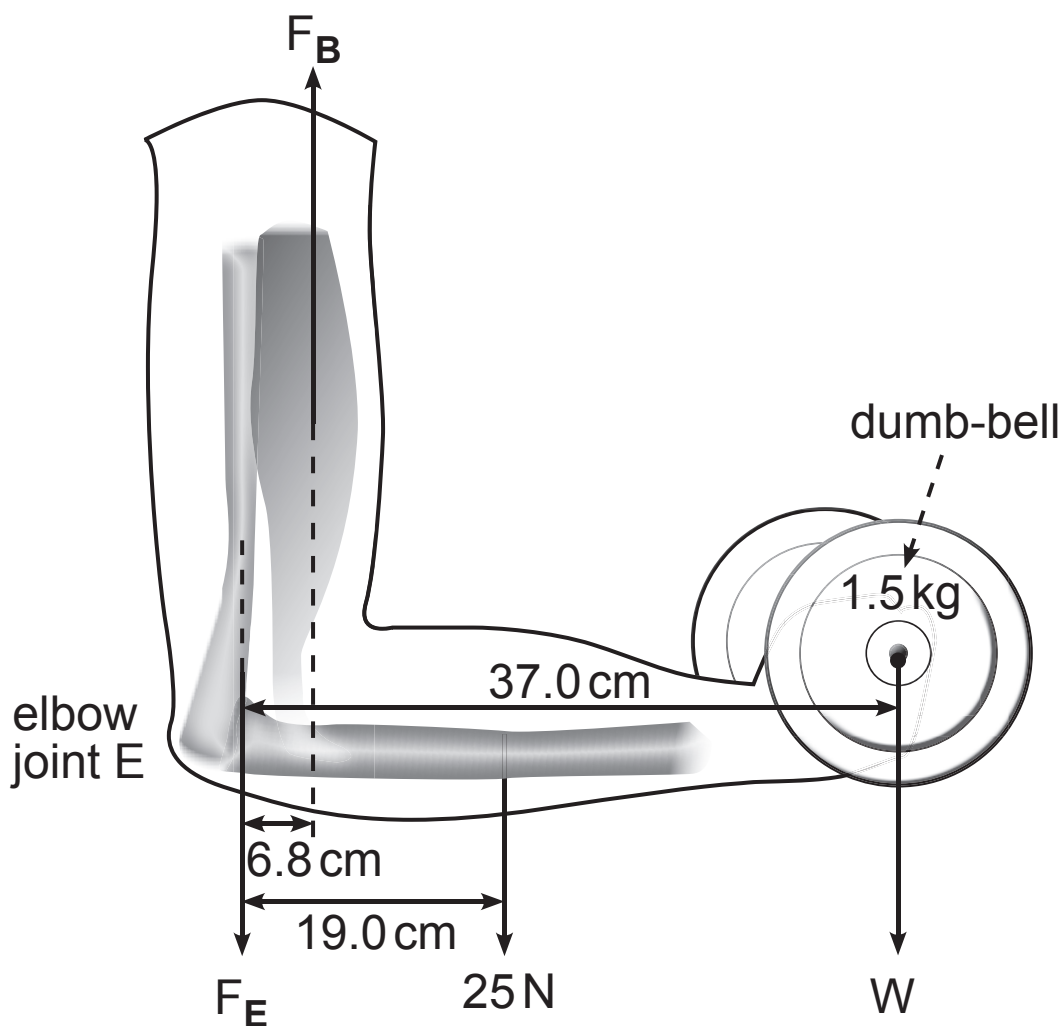

Fig. 5.1

- (i) Use the principle of moments to calculate the magnitude of the force in the bicep F_B . [3 marks]

Force in bicep $F_B =$ _____ N

- (ii) 1. State an expression for the vertical force at the elbow joint F_E in terms of the other forces acting when the arm is held horizontal with the dumb-bell in the hand. [1 mark]

2. Determine the magnitude of the vertical force acting at the elbow joint F_E . [1 mark]

Force at elbow joint $F_E =$ _____ N

6 (a) (i) Define the **Young modulus** of a material. [1 mark]

(ii) The S.I. unit for the Young modulus is the pascal.

Express the pascal in S.I. base units. [1 mark]

S.I. base units for
the Young modulus = _____

(b) The seat of a garden swing is uniform and has a mass of 1 kg. It is 0.4 m long, made from a light but rigid material and suspended horizontally by two wires as shown in **Fig. 6.1** opposite. One wire is made of nickel and has a diameter 1.90 mm. The other wire is made of copper; each wire is 5.0 m long. When a boy of mass 40 kg sits on the middle of the seat it remains horizontal.

Young modulus for nickel = 1.70×10^{11} Pa

Young modulus for copper = 1.17×10^{11} Pa

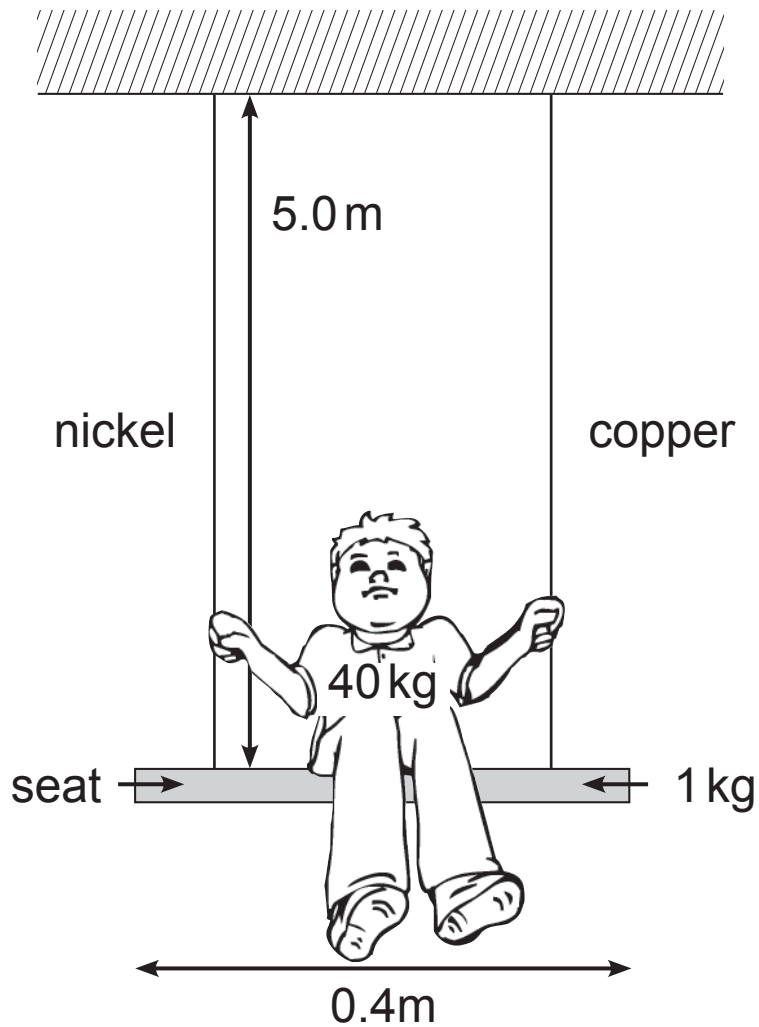

Fig. 6.1

(i) State the tension in each wire. [1 mark]

Tension = _____ N

- (ii) The stress in the nickel wire is 7.05×10^7 Pa.
Calculate the strain in this wire. [2 marks]

Strain = _____

- (iii) Calculate the extension of the nickel wire. [1 mark]

Extension = _____ mm

- (iv) Calculate the diameter of the copper wire. [4 marks]

Diameter of copper wire = _____ mm

BLANK PAGE

(Questions continue overleaf)

7 (a) Define the resistivity of a material. [1 mark]

(b) The resistivity of **tungsten** is of the order of $10^{-8} \Omega \text{m}$ and that of **polystyrene** is $10^{15} \Omega \text{m}$.

Explain the large difference in the resistivity of tungsten and polystyrene in terms of charge carriers. [2 marks]

- (c) (i) Sketch a graph on **Fig. 7.1** to show the variation in resistivity with temperature of tungsten. It becomes superconducting at 5K. [2 marks]

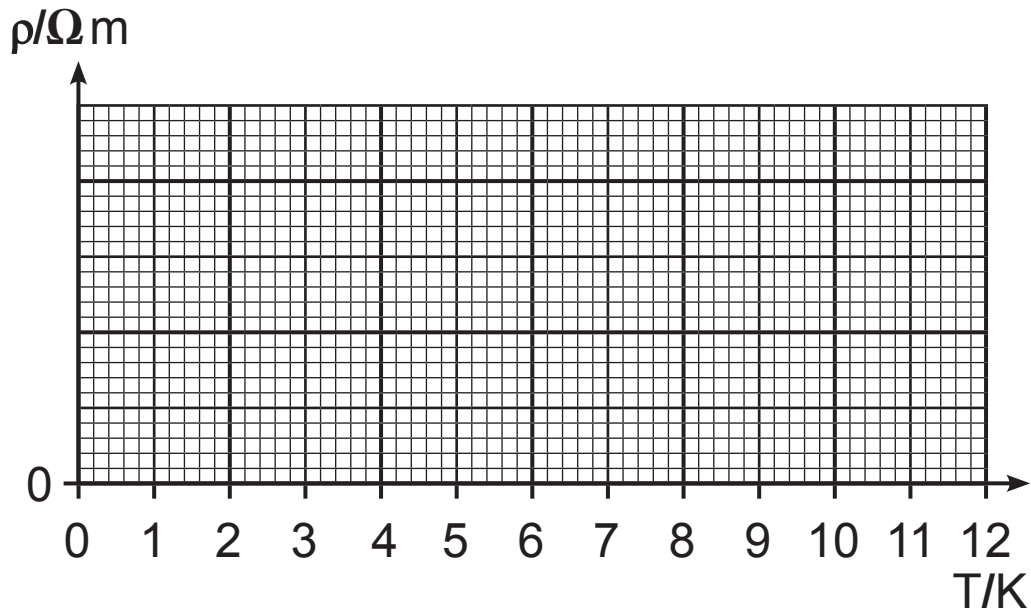

Fig. 7.1

- (ii) What is the name of the temperature at which a material becomes a superconductor? [1 mark]

- (iii) The highest temperature that has been found for certain ceramic alloys to exhibit superconductivity is approximately -135°C or 138 K. Explain why the search for materials that exhibit superconductivity at room temperature (20°C or 293 K) would be a major technological breakthrough. [1 mark]

8 Electromotive force, terminal potential difference and internal resistance are terms used when discussing a battery.

(a) Define electromotive force. [1 mark]

(b) A student sets up the circuit shown in **Fig. 8.1** to experimentally find the electromotive force E and internal resistance, r , of a battery. The student records the current I from the ammeter and the terminal potential difference V from the high resistance voltmeter.

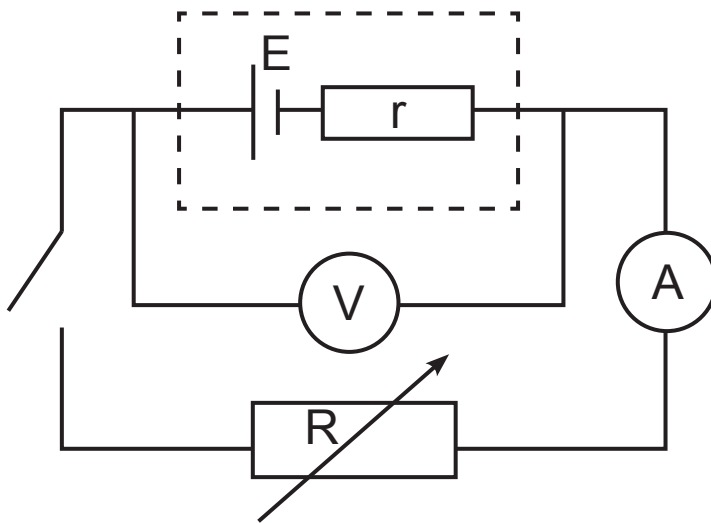

Fig. 8.1

- (i) For the circuit shown in **Fig. 8.1** on page 24, complete **Table 8.1** by placing a tick in the correct box to show how the magnitude of the e.m.f. compares to the terminal potential difference (tpd) when the switch is open and closed. [1 mark]

Table 8.1

	e.m.f. > tpd	e.m.f. = tpd	e.m.f. < tpd
Switch open			
Switch closed			

The student varies R and obtains a set of voltmeter and ammeter readings. **Fig. 8.2** opposite is a graph of these results.

- (ii) Use your graph to determine the electromotive force of the battery. [1 mark]

Electromotive force = _____ V

- (iii) Determine the value of the internal resistance of the battery. [2 marks]

Internal resistance = _____ Ω

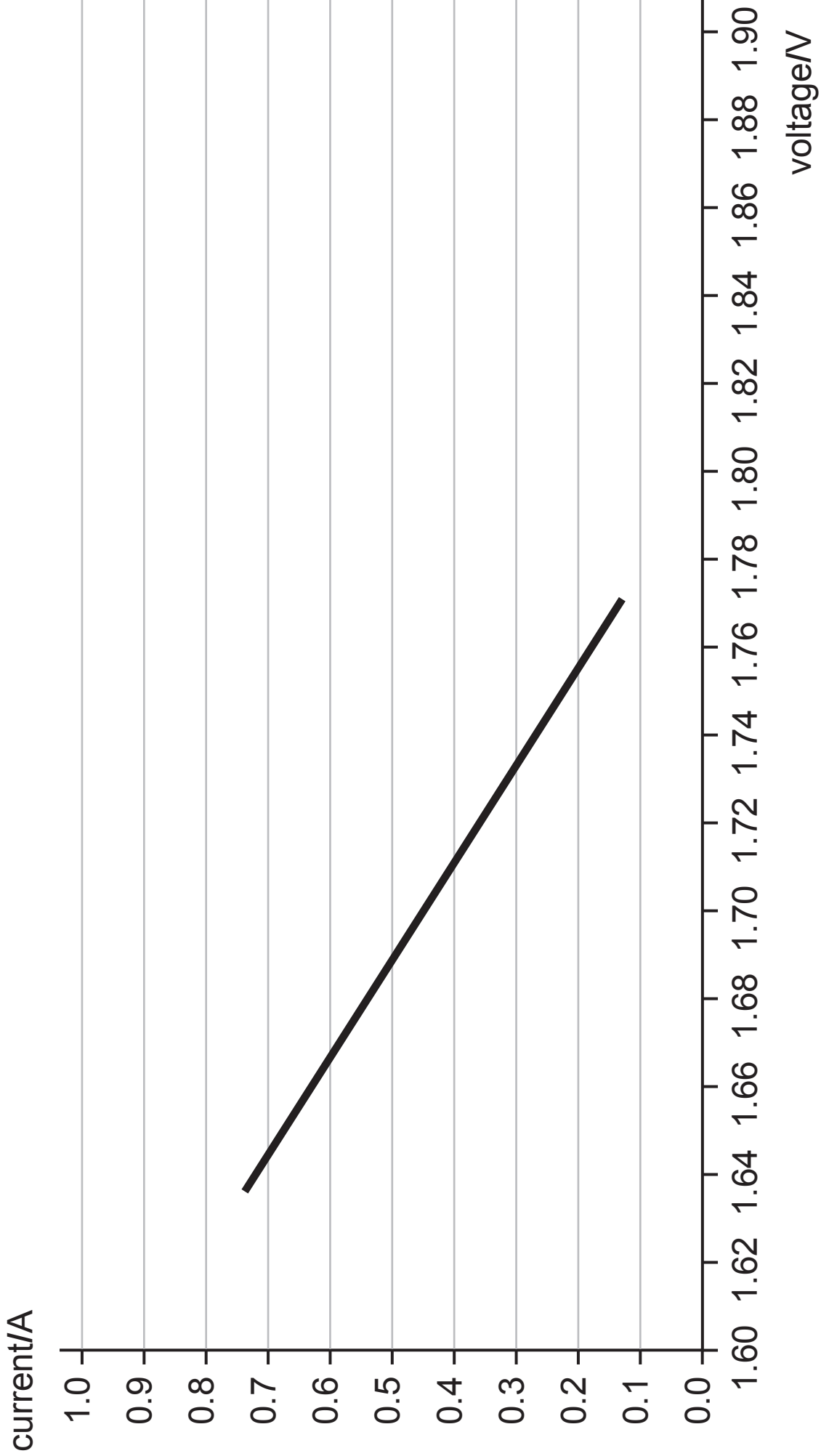

- 9 Fig. 9.1 shows a number of resistors connected in series and parallel to a 15V battery of negligible internal resistance.

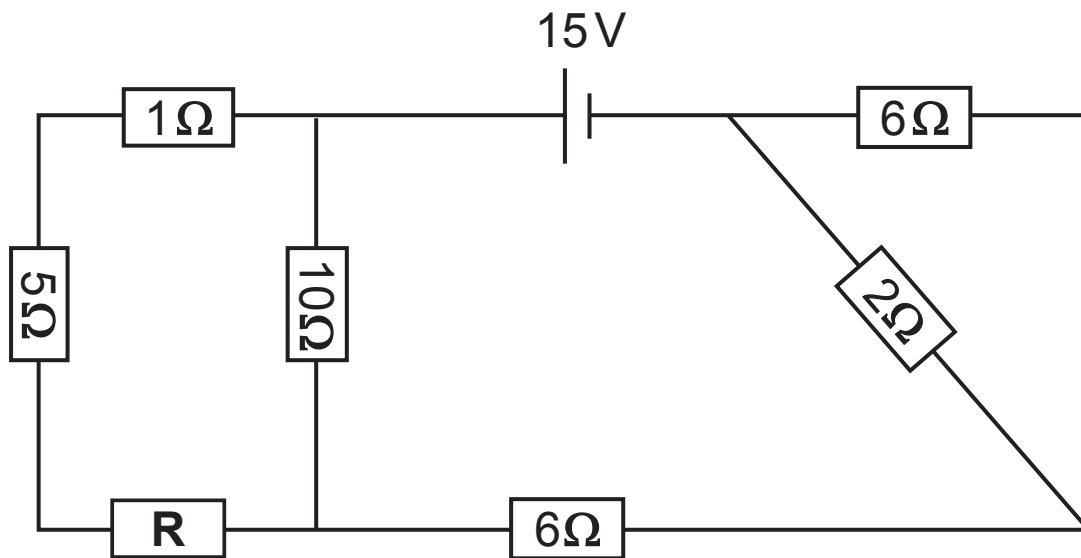

Fig. 9.1

- (a) The overall resistance of the circuit is 12.5Ω . Calculate the value of the resistor labelled **R** in the circuit.
[4 marks]

$R = \underline{\hspace{2cm}} \Omega$

(b) Calculate the current flowing through the 2Ω resistor and hence the power dissipated in it. [3 marks]

Current = _____ A

Power = _____ W

10 A 15V battery is connected to a circuit that provides a voltage V_{out} that depends on the brightness of a room. The brightness of the room is sensed by a light-dependent resistor (LDR). This LDR is connected to a $300\ \Omega$ fixed resistor to form a potential divider as shown in **Fig. 10.1**. The resistance of the LDR varies from a minimum of $10\ \Omega$ in bright conditions to a maximum of $250\ \Omega$ in dark conditions.

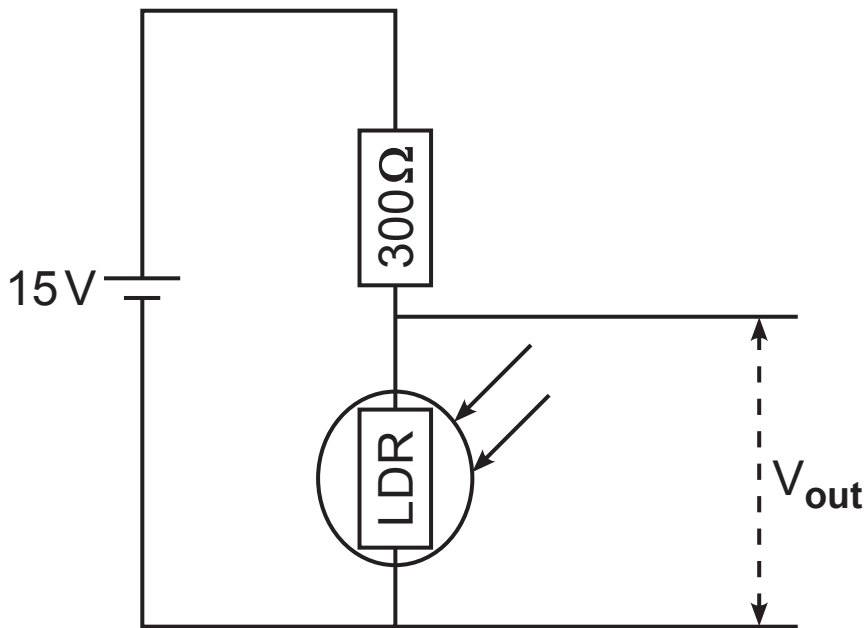

Fig. 10.1

(a) Calculate the output voltage V_{out} when the room is brightly lit. [2 marks]

V_{out} in bright conditions = _____ V

(b) The circuit is altered so that an external load containing a small motor is connected across the LDR. This causes a window blind to be closed automatically when the room becomes dark. The voltage across the motor must be 6 V for the motor to close the blind. The altered circuit is shown in **Fig. 10.2**.

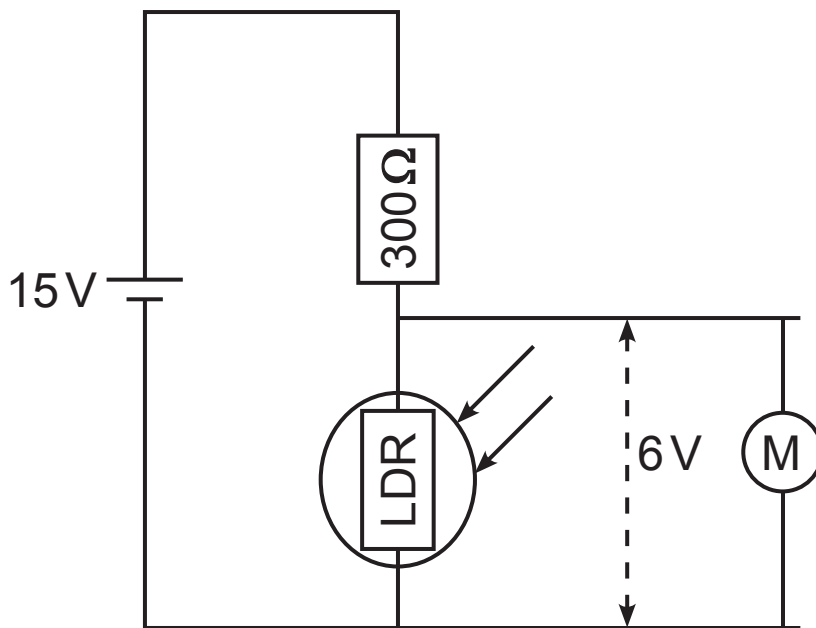

Fig. 10.2

Calculate the resistance of the external load circuit containing the motor. [4 marks]

Resistance of motor $R_m = \underline{\hspace{2cm}} \Omega$

THIS IS THE END OF THE QUESTION PAPER

Sources

Q2, Fig2.2, Pg 6 image of old sports car, © Alexander Babich/ iStock / Thinkstock

For Examiner's use only		
Question Number	Marks	Remark
1		
2		
3		
4		
5		
6		
7		
8		
9		
10		
Total Marks		

Permission to reproduce all copyright material has been applied for.
 In some cases, efforts to contact copyright holders may have been unsuccessful and CCEA will be happy to rectify any omissions of acknowledgement in future if notified.