



Rewarding Learning

ADVANCED SUBSIDIARY (AS)
General Certificate of Education
2011

Centre Number

71

Candidate Number

Physics

Assessment Unit AS 3

assessing

Practical Techniques (Internal Assessment)

Session 2

[AY132]



FRIDAY 13 MAY, MORNING

TIME

1 hour 30 minutes.

INSTRUCTIONS TO CANDIDATES

Write your Centre Number and Candidate Number in the spaces provided at the top of this page.

Turn to page 2 for further Instructions and Information.

Question Number	Marks	
	Teacher Mark	Examiner Check
1		
2		
3		
4		
5		
Total Marks		



INSTRUCTIONS TO CANDIDATES

Answer **all** the questions in this booklet. Rough work and calculations must also be done in this booklet. Except where instructed, do **not** describe the apparatus or experimental procedures. The Teacher/Supervisor will tell you the order in which you are to answer the questions. One hour is to be spent on Section A and 30 minutes on Section B.

Section A consists of four short experimental tests. **You will have access to the apparatus for 13 minutes for each of the tests.** At the end of this 13-minute experimental period there is a 2-minute changeover to the area set aside for the next test. Any spare time before the start of the next test may be used to write up anything you have not yet completed.

At the end of your Section A work you will be told to move to the area set aside for Section B. Section B consists of one question in which you will analyse a set of experimental results.

INFORMATION FOR CANDIDATES

The total mark for this paper is 40.

Section A and Section B carry 20 marks each.

Figures in brackets printed down the right-hand side of pages indicate the marks awarded to each part question.

You may use an electronic calculator.

BLANK PAGE

(Questions start overleaf)

Section A

1 In this experiment you are to investigate how the period of oscillation of a system of springs varies as the number of springs in parallel in the system is increased.

(a) The apparatus in **Fig. 1.1** has already been set up for you. Systems with two and three springs have also been provided on the bench.

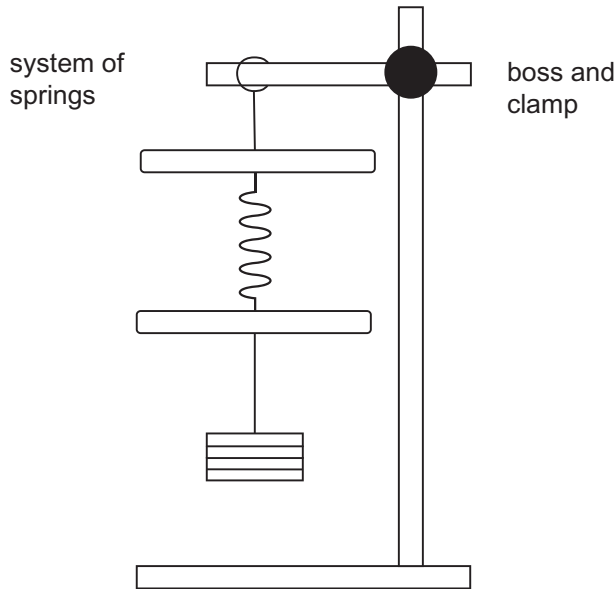

Fig. 1.1

Displace the mass carrier a small distance, release and allow it to oscillate. Take readings to allow you to determine T , the period of the oscillation. Record **all** your results in **Table 1.1**.

Replace the system of one spring with the system of two springs and repeat the above procedure.

Finally replace the system of two springs with the system of three springs and repeat the above procedure.

Table 1.1

Number of springs		T/s
1		
2		
3		

[3]

Teacher Mark	Examiner Check	Remark

(b) It is suggested that the relationship between the period T of the oscillations of the spring system and the number of springs N is one of the following:

(i) $T = 2\pi\sqrt{\frac{Nm}{k}}$

(ii) $T = 2\pi\sqrt{\frac{m}{Nk}}$

(iii) $T = 2\pi\sqrt{\frac{m}{k}}$ i.e. T is independent of N

where m and k are constants.

Using your results in **Table 1.1**, choose which of the equations correctly describes the trend of your results. Explain your answer.

Equation _____

Explanation:

_____ [2]

Teacher Mark	Examiner Check	Remark

- 2 In this experiment you are to obtain a value for the focal length of a converging lens using the lens formula.

Fig. 2.1 shows the arrangement of the apparatus which has already been set up for you.

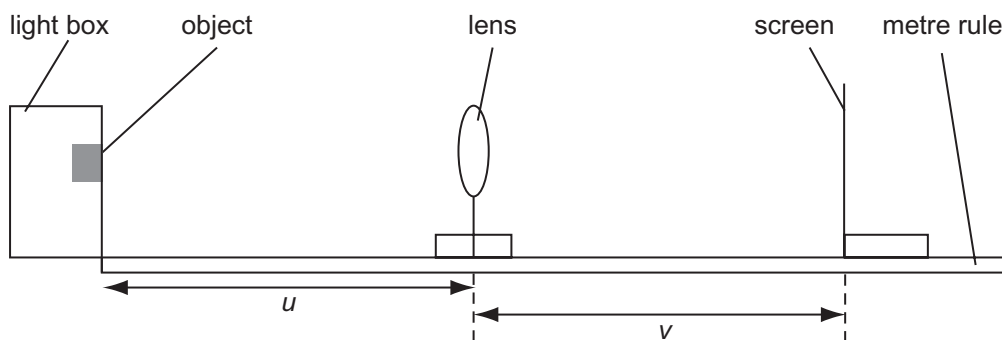

Fig. 2.1

The distance u has been set at 32.0 cm for your first reading.

- (a) **Without moving the object or the lens**, adjust the position of the screen until a focused image of the object is seen on the screen. Measure the distance v between lens and screen. Record the value of v in **Table 2.1**.

Repeat the above procedure for $u = 40.0$ and $u = 50.0$ cm. Record the corresponding values of v in **Table 2.1**.

Table 2.1

u/cm	v/cm
32.0	
40.0	
50.0	

[1]

Teacher Mark	Examiner Check	Remark

(b) A relationship between u and v is given by the **Equation 2.1**.

$$\frac{1}{u} + \frac{1}{v} = \frac{1}{f} \quad \text{Equation 2.1}$$

- (i) Use **Equation 2.1** and the result for $u = 50.0$ cm in **Table 2.1** to calculate a value for f .

$f =$ _____ cm [2]

- (ii) Explain how you would obtain a more accurate value of f using the results from **Table 2.1**.

_____ [1]

- (iii) What is the major source of uncertainty in this experiment?

_____ [1]

Teacher Mark	Examiner Check	Remark

3 In this experiment you are to measure the diameter and thickness of a 100 g slotted mass and find the thickness to diameter ratio.

You are provided with two measuring instruments, a micrometer screw gauge and a vernier calliper.

(a) Which of the two measuring instruments are you going to choose to measure the **diameter** of the 100 g slotted mass? Give a reason for your choice and state the uncertainty in a measurement using the instrument.

Instrument: _____

Uncertainty: \pm _____ mm [2]

For this question you are not expected to take repeat readings.

(b) Measure the diameter of the 100 g slotted mass and record the result below. Give your answer to an appropriate number of decimal places.

Diameter = _____ mm [1]

(c) Measure the thickness of the 100 g slotted mass. Give your answer to an appropriate number of decimal places.

Thickness = _____ mm [1]

(d) Hence calculate the ratio of the thickness of the slotted mass to its diameter.

Ratio = _____ [1]

Teacher Mark	Examiner Check	Remark

BLANK PAGE

(Questions continue overleaf)

- 4 In this experiment you are to calculate the resistance of three pieces of wire which are of the same length, same material but have a different thickness. The wires are inside a sealed box. You are then to establish which wire has been connected to which pair of terminals.

Fig. 4.1 shows the circuit containing the sealed box, a power supply, switch, ammeter and voltmeter. The meters can be used to determine the resistance between selected pairs of terminals. One of the wires is soldered between terminals W and X, another is soldered between W and Y and the final wire is soldered between W and Z.

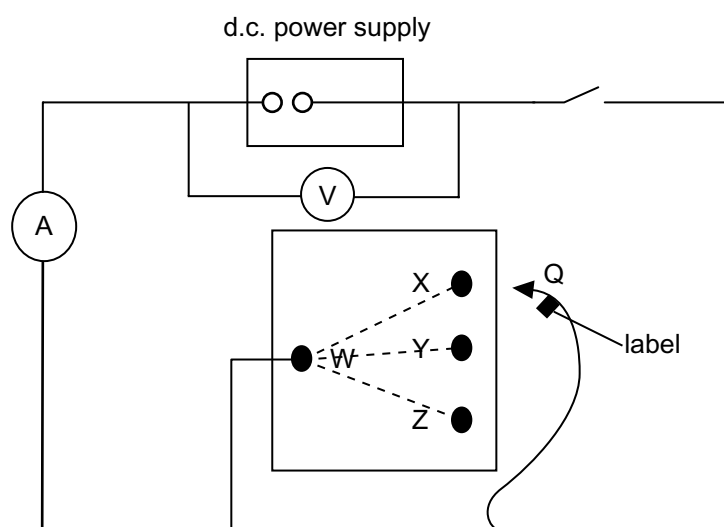

Fig. 4.1

- (a) Connect lead Q to terminal X. Hold the switch closed and record the values of current and voltage, shown on the meters, in **Table 4.1**. Repeat this process for lead Q connected to Y and then Z.
Note: the switch should only be closed as a reading is being taken.

Table 4.1

terminals	V/V	I/A	R/ Ω
W and X			
W and Y			
W and Z			

[2]

Teacher Mark	Examiner Check	Remark

(b) Hence calculate the resistance of each thickness of wire and record your results in **Table 4.1**. [1]

(c) By examining your results, establish across which terminals the thickest and thinnest wires are connected. Explain your reasoning.

Thickest wire is soldered between W and _____

Thinnest wire is soldered between W and _____

Explanation:

[2]

Teacher Mark	Examiner Check	Remark

BLANK PAGE

Section B

5 The potential divider circuit

A circuit diagram of a potential divider circuit is shown in **Fig. 5.1**.

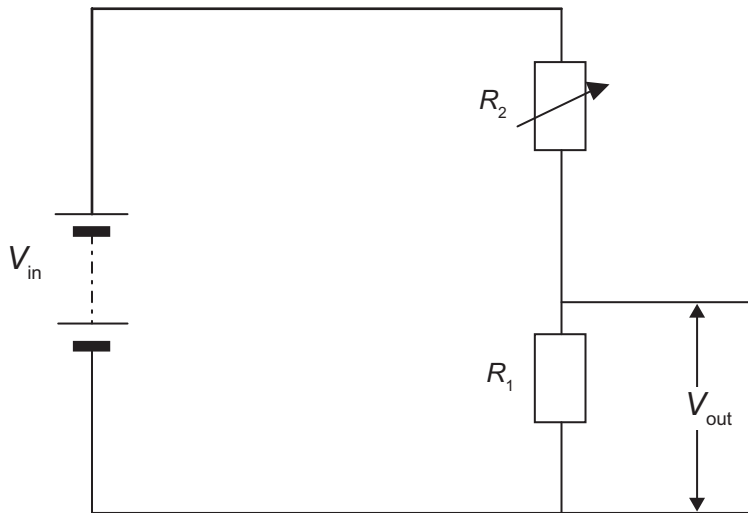

Fig. 5.1

R_2 is a variable resistor. The values of V_{in} and R_1 are not known. A student uses the apparatus to measure V_{out} for several values of R_2 . The results obtained are recorded in **Table 5.1**.

Table 5.1

R_2/Ω	V_{out}/V	
50	8.2	
100	6.0	
150	4.8	
200	4.0	
250	3.4	

The relationship between R_2 and V_{out} is given by **Equation 5.1**.

$$\frac{1}{V_{out}} = \frac{R_2}{V_{in} R_1} + \frac{1}{V_{in}} \quad \text{Equation 5.1}$$

Teacher Mark	Examiner Check	Remark

- (a) Use **Equation 5.1** to show that a graph of $\frac{1}{V_{\text{out}}}$ plotted against R_2 will result in a straight line graph of gradient $\frac{1}{V_{\text{in}}R_1}$ and intercept $\frac{1}{V_{\text{in}}}$.

[2]

Data Processing

- (b) (i) Head the blank column of **Table 5.1** with the quantity that should be plotted to draw the graph in (a) and include appropriate unit. [1]
- (ii) Calculate the numerical values required to complete the blank column in **Table 5.1** to an appropriate number of significant figures. [2]
- (iii) On the grid of **Fig. 5.2** opposite, draw the graph of the processed data in **Table 5.1**. Label the axes and choose suitable scales. Plot the points and draw the best fit straight line. [5]

Analysis

- (c) (i) Determine the value of V_{in} .

$$V_{\text{in}} = \text{_____ V} \quad [2]$$

Teacher Mark	Examiner Check	Remark

(ii) Determine the experimental percentage uncertainty in V_{in} by drawing a line of extreme fit on Fig 5.2.

Uncertainty = \pm _____ % [4]

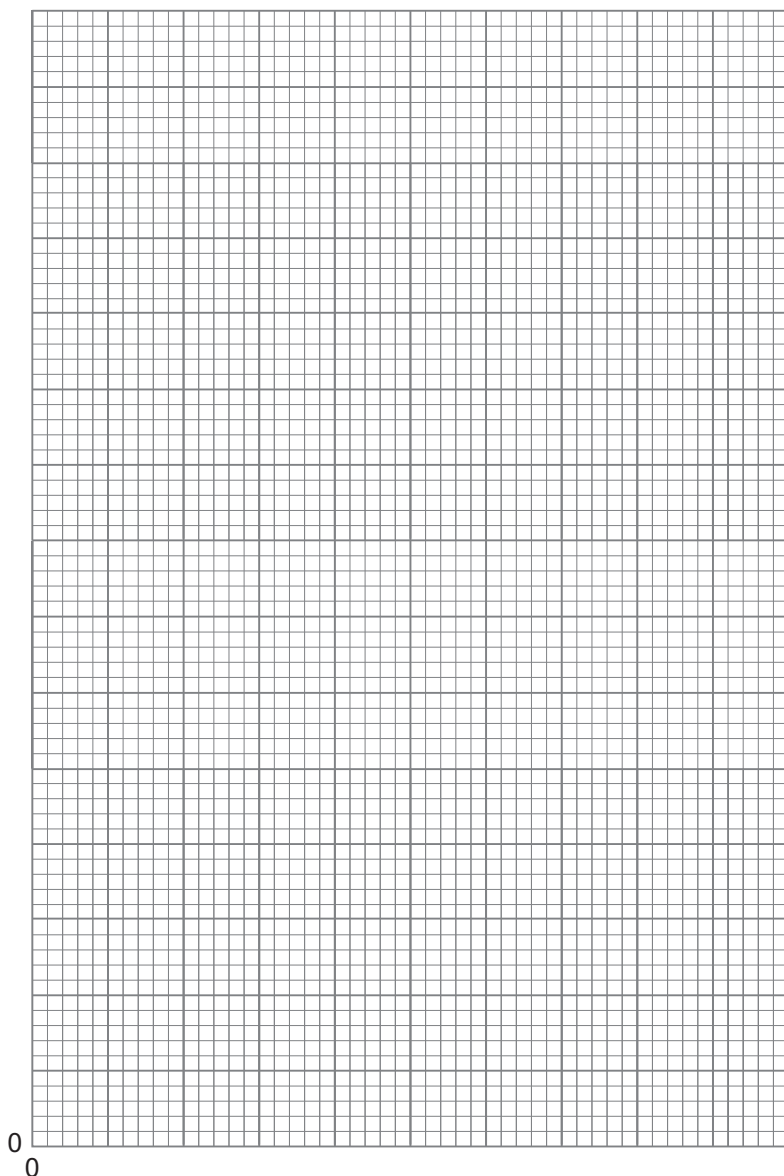

Fig. 5.2

(iii) Calculate the value of R_1

$R_1 =$ _____ Ω [4]

Teacher Mark	Examiner Check	Remark

Permission to reproduce all copyright material has been applied for.
In some cases, efforts to contact copyright holders may have been unsuccessful and CCEA
will be happy to rectify any omissions of acknowledgement in future if notified.