

General Certificate of Education
June 2006
Advanced Level Examination



PHYSICS (SPECIFICATION B)

PHB6/TN

Unit 6

Instructions to Supervisors

STRICTLY CONFIDENTIAL

It is the responsibility of the Examinations Officer to ensure that these Instructions to Supervisors are given immediately to the Supervisor of the practical exercises.

These Instructions are strictly confidential and must be kept in safe custody by the Examinations Officer or by the Supervisor. They should be given to the Invigilator for the duration of the actual assessment and afterwards returned to the Examinations Officer. The Invigilator must ensure that when the Instructions are not in use, they are returned and kept in safe custody. Additional copies of these Instructions cannot be supplied by AQA.

No copies of the relevant question paper should be given to the Supervisor at any time leading up to the examination.

INSTRUCTIONS TO THE SUPERVISOR OF THE PRACTICAL EXERCISES

General

- 1 The instructions and details of materials contained in this document are for the use of the Supervisor **and are strictly confidential**. After use, these Instructions must be kept in safe custody by the Examinations Officer until after the issue of results (in March or August as appropriate).
- 2 **The Supervisor has now been granted access to the question papers for both Exercise 1 (PHB6/1) and Exercise 2 (PHB/2) as part of these Instructions. All the relevant questions are printed to enable the Supervisor to carry out the experimental parts of the Exercises in order to ensure that the apparatus and materials obtained are satisfactory and to seek advice from AQA if there are any problems. The Instructions must be returned to safe custody at the earliest possible moment after the Supervisor has ensured that all is in order.**
- 3 Candidates are allowed 1 hour 30 minutes for each of Exercises 1 and 2.
- 4 Exercise 1 (PHB6/1) is undertaken at a time suited to the circumstances of the centre, but under examination conditions. It is preferred that all candidates at a given centre undertake Exercise 1 at the same time.
- 5 About two weeks before candidates at a particular centre undertake Exercise 1, each candidate should be given a copy of the Preliminary Material (Information for Candidates) (PHB6/PM). This gives details of the general subject area of this assessment. The information is given to all candidates so that those undertaking the assessment early are not disadvantaged.
- 6 Exercise 2 (PHB6/2) is a timetabled practical examination and should be undertaken on the stipulated day. In a centre with a large number of candidates, it may be necessary for two or more examination sessions to be organised for Exercise 2. Candidates waiting for their session must be fully invigilated in a separate room throughout the period from the time of the first session until they enter the examination room. Candidates completing their session before the published starting time for the examination must similarly be invigilated.
- 7 For Exercise 2, centres may provide sufficient sets of apparatus for half their candidates to work on Question 1, while the other half work on Question 2. Under strict supervision, the groups of candidates change over after 45 minutes. It will be necessary to allow a short period of time whilst the change over takes place. During this time the apparatus should be returned to its original state, ready for use by the next group of candidates. A similar short delay for the same purpose will be needed in centres running two or more sessions.
- 8 The exercises are **not** open-book examinations – candidates must **not** have access to textbooks, course notes, etc. However, the question papers for both exercises include the AS and A2 Formulae Sheets.
- 9 AQA will provide graph paper for both exercises. For PHB6/1 a question paper and separate 8-page answer book will be provided. For PHB6/2 a combined question paper/answer booklet will be provided. All other materials required for the assessment must be provided by the centre.

-
- 10** A suitable laboratory, or laboratories, must be reserved for the practical exercises. Enough apparatus and materials must be prepared to ensure that in the case of failure of a set of apparatus, a substitute is available so that the candidate does not lose time. Unauthorised persons not involved in the preparation for the examination must not be allowed to enter. Candidates must not be admitted until the specified time for commencement of the examination. The examination room must be cleared of candidates immediately after the examination.
- 11** The apparatus and materials for each candidate must be arranged neatly, and ready to use, on the laboratory bench. No attempt should be made to connect together any parts or to wire up any electrical circuits except when specifically stated in these Instructions.
- 12** Clear instruction must be given by the Supervisor to all candidates at the beginning of each examination concerning the organisation of the examination in the laboratory and the amount of time allowed for the examination. Candidates must also be instructed that all readings must be entered in the answer book provided and all working must be shown. **Scrap paper must not be used.**
- 13** If a candidate is unable to perform any experiment, or is performing an experiment incorrectly, the Supervisor is expected to give the minimum help required to enable the candidate to proceed. In this instance, a note bearing the candidate's name and number must be attached to the candidate's script reporting to the Examiner the extent of the help given. Any failure in the apparatus should also be reported to the Examiner. **No help should be given with the analysis of the experimental data.**

It is not the wish of the Examiner that a candidate should waste time because of, for example, an incorrect electrical connection. The Examiner wishes to test the candidate's ability to perform an experiment and carry out the subsequent analysis.

- 14** Candidates' scripts **and**, where appropriate, the question papers for PHB6/1 should be collected at the end of each exercise. Under no circumstances should candidates be permitted to remove question papers from the examination room. Note that candidates will require separate sheets of A4 graph paper which should be secured to the script for the appropriate exercise using a treasury tag.
- 15** Used question papers must be returned to the safe custody of the Examinations Officer, by whom they should be retained until after the issue of results.
- 16** **Candidates' scripts for Exercise 1 must be stored securely until the stipulated date for Exercise 2. Scripts for the two exercises should be collated and sent together to the Examiner.**
- 17** If a candidate is absent on the stipulated date for Exercise 2, their script for Exercise 1 should still be sent to the Examiner. The flexibility in the timing for Exercise 1 should make it possible for all candidates to be given an opportunity to undertake Exercise 1.
- 18** The Supervisor is required to report details concerning the experiment, apparatus or materials to the Examiner on the *Supervisor's Report* located at the end of this document. ***This Supervisor's Report must be attached to the topmost script before despatch to the Examiner.***

Details must be given on the *Supervisor's Report* if the apparatus or materials provided differ from that detailed in this document. Where specific information or data about apparatus or materials is

Turn over ►

requested in these Instructions, it is important that it is given accurately. In some cases it may represent the only means available to the Examiner of assessing the accuracy of a candidate's work.

Centres may make copies of this *Supervisor's Report* for attachment to individual scripts if necessary. If all the information cannot easily be included on the *Supervisor's Report*, separate sheets of paper, bearing the candidates' names and numbers, can be attached to the relevant candidates' scripts.

In case of difficulty the Supervisor should telephone the Senior Subject Officer for A Level Physics, David Baker, at AQA (Manchester Office), telephone number 0161 953 1180, or e-mail dbaker@aqa.org.uk.

Exercise 1

Candidates will investigate the friction between string and plastic.

Apparatus and materials

- (a) expendable steel spring with a spring constant of approximately 25 N m^{-1} and a short length of string, about 50 mm;
- (b) wooden strip of approximate dimensions 250 mm x 20 mm x 5 mm;
- (c) nail or screw hook;
- (d) 2 mm graph paper;
- (e) adhesive (e.g. PrittStick);
- (f) 0.070 kg load (e.g. a 50 g mass hanger and a 20 g mass);
- (g) plastic cylinder with diameter approximately 25 mm, e.g. a 20 ml plastic syringe;
- (h) about 1 m of thin string, approximately 1 mm diameter;
- (i) scissors; (one pair between three or four candidates will suffice);
- (j) two retort stands, bosses and clamps;
- (k) G-clamp or other means of stabilising one of the retort stands;
- (l) card stating the circumference of the plastic cylinder in mm to 2 significant figures, e.g. circumference = 79 mm.

The apparatus to be arranged by the candidate is shown in **Figure A**.

Cut a strip of graph paper 240 mm x 20 mm and fix it to the wooden strip using the adhesive. Label the markings in cm every 2 cm (0, 2, 4, 6, 8 etc) as shown in **Figure B**.

Insert a nail or screw at the zero mark and fix one end of the spring to it. Use a short length of string to fix it so that it cannot be removed.

The spring should be pre-stretched so that the turns are separated by 1 mm to 2 mm. The overall length of the spring should then be about 80 mm. A spring with larger separation may be used but if the spring is too long it will be more difficult for the candidate to identify the point of slipping and make the appropriate length measurements.

When the candidate starts the experiment the plastic cylinder should be clamped to one of the retort stands which should be firmly fixed or stabilised using item (k). The remaining apparatus should be placed nearby.

Turn over ►

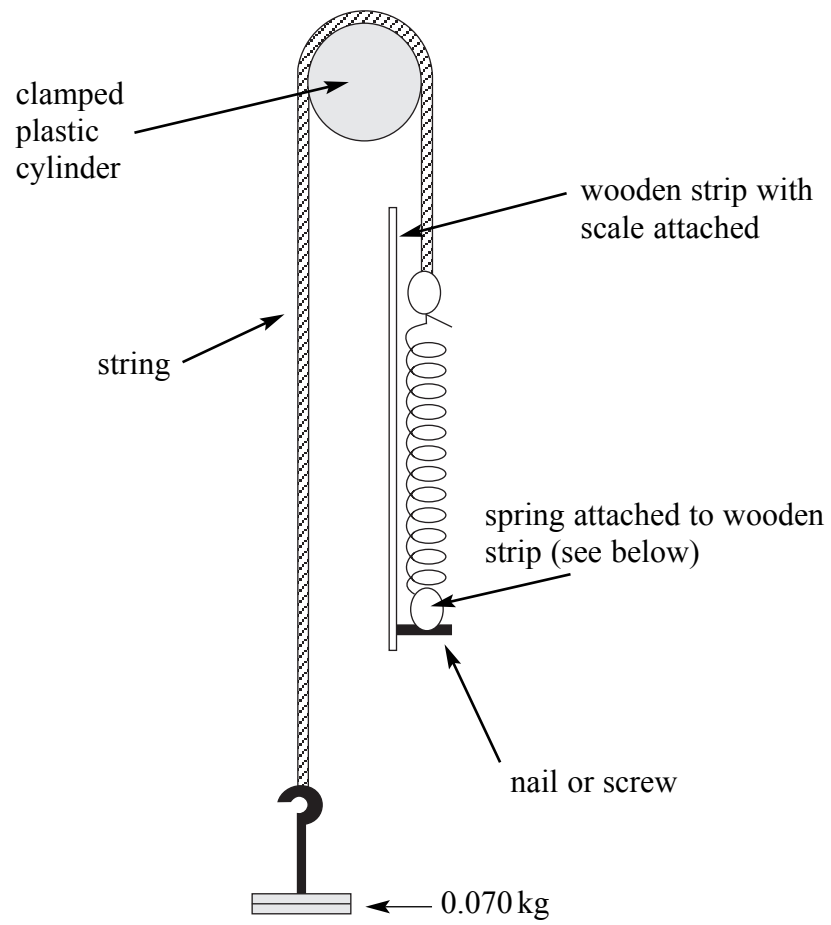
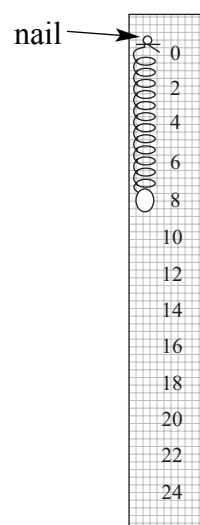
Figure A**Figure B**

Exercise 2

Question 1

Candidates will be required to explain observations of a system in which a force acts on a current carrying conductor in a magnetic field.

Apparatus and materials

- (a) strip of wood of approximate dimensions $100\text{ mm} \times 30\text{ mm} \times 10\text{ mm}$;
- (b) two nails approximately 30 mm long and 2 mm diameter;
- (c) ceramic (Magnadur) magnet of approximate dimensions $50\text{ mm} \times 18\text{ mm} \times 5\text{ mm}$ with poles on the largest faces;
- (d) kitchen foil (see below);
- (e) Blu-Tack;
- (f) 6 V dc supply, e.g. four 1.5 V cells in a suitable holder;
- (g) variable resistor, e.g. rheostat (see below);
- (h) two leads each terminated by a crocodile clip at one end;
- (i) further leads as required;
- (j) switch labelled **S** with the ON position clearly indicated;
- (k) retort stand, boss and clamp.

The apparatus to be arranged for the candidate is shown in **Figure C**. Photographs of the arrangement are shown in **Figure D**.

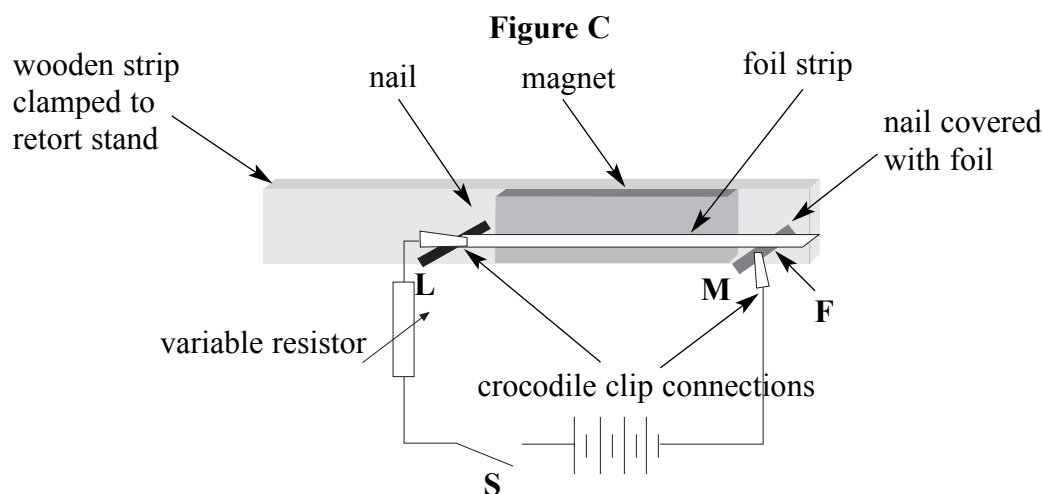

Turn over ►

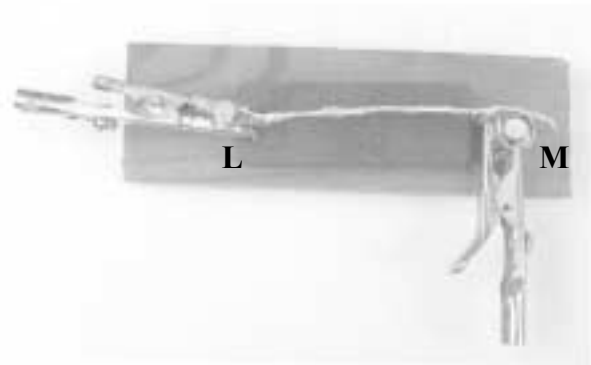
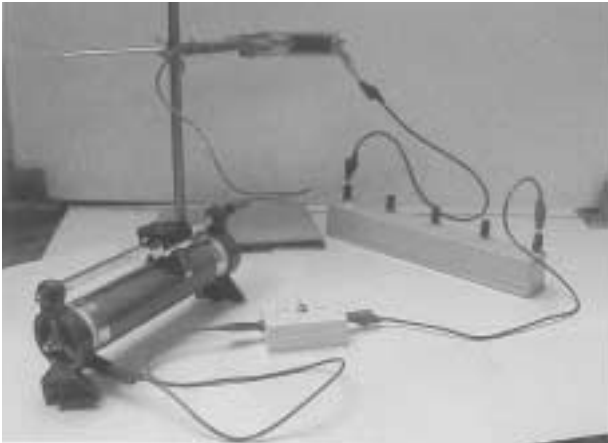
Figure D

The following instructions give a suitable sequence for making the arrangement.

Knock the nails into the wood so that they are about 4 mm further apart than the length of the magnet. A minimum length of 20 mm of nail should be left protruding from the wood.

Fix the magnet to the wooden strip using Blu-Tack so that it is between the nails but not touching them.

Wrap a strip of kitchen foil around nail **M** and flatten it to form a horizontal conducting 'platform' about 5 mm across.

Cut a strip of kitchen foil approximately 80 mm × 5 mm. Attach one end to the other nail **L** using the crocodile clip on one of the leads. Adjust the position so that the strip is approximately horizontal and resting on **M**. It will be necessary to fix the lead that is attached to **L** so that it does not cause the foil strip to lose contact with **M**.

Connect a lead to **M** using a crocodile clip.

When the circuit is connected as shown in **Figure C** the strip should be seen to vibrate vertically. If it does not vibrate then reverse the polarity of the supply.

In trials a rheostat with a total resistance of about 10 Ω was found to be suitable but this is not critical. The only criterion is that when the resistance of the variable resistor is increased, the amplitude of vibration of the strip is seen to decrease.

When the candidate begins using the apparatus the variable resistor should be set to zero resistance. The strip may occasionally stop vibrating but adjusting it slightly should set it vibrating again.

(Supervisors may wonder why the nail **M** is covered with foil. Although the system can be made to work without the foil, trials showed that the small area of contact can produce sparks which can affect conduction during the intermittent contact of the vibrating foil with **M**. The larger area of contact is less susceptible to sparking and is therefore more reliable.)

Question 2

Apparatus and materials

- (a) variable dc power supply capable of supplying potential differences from 0 V to 3 V (see below);
- (b) 2.5 V 0.3 A filament lamp in a suitable holder;
- (c) voltmeter suitable for reading potential differences up to 3.0 V;
- (d) ammeter suitable for reading currents up to 0.5 A;
- (e) switch labelled **S** with the ON position clearly indicated;
- (f) leads;
- (g) red filter;
- (h) cylinder of black paper (see below);
- (i) thermometer;
- (j) card stating the resistance of the filament at room temperature to 2 significant figures, e.g. ' $R = (2.4 \pm 0.1)\Omega$ '

The circuit shown in **Figure E** should be set up ready for the candidate.

Figure E

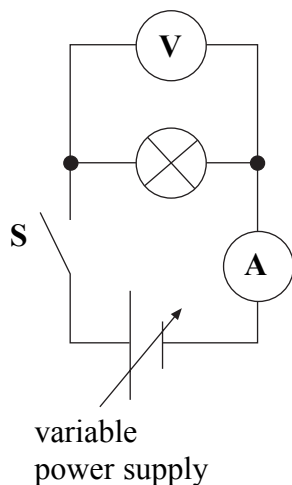
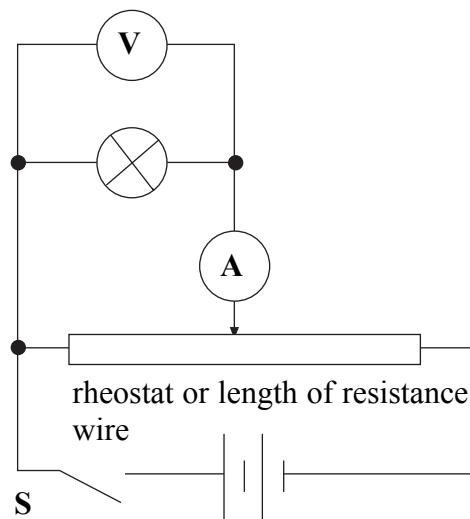

Figure F



The variable power supply may be an electronic supply or be made from two 1.5 V cells in a suitable holder with a suitable rheostat used as a potential divider, as shown in **Figure F**.

Turn over ►

Should insufficient rheostats be available a suitable alternative is a length of resistance wire with a resistance between $7\ \Omega$ and $15\ \Omega$, e.g. about 50 cm of 0.25 mm or 0.32 mm diameter (30 or 32 gauge) nichrome. This can be fixed to a wooden strip using adhesive tape. Crocodile clips can be used for making contact with the wire.

The black paper cylinder is to exclude extraneous light so that it is easier to identify when the filament just glows. The length of the cylinder should be such that it extends about 20 mm above the end of the lamp.

The resistance of the filament at room temperature (for item (j)) may be measured using an ohm-meter or using the circuit in **Figure E** with a current of no more than a few mA.

END OF TEACHERS NOTES

1 You are going to investigate the friction acting between string and plastic when the string is wrapped around a plastic cylinder.

(a) You have been provided with a spring that is attached to a wooden strip with a scale.

(i) Measure l_0 , the length of the spring with no load.

The length measured throughout the experiment is the total length including the loops at each end, as shown in **Figure 1**.

Figure 1

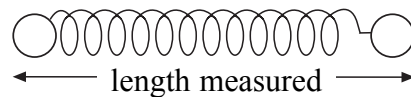

(ii) Measure L , the length of the spring when a load of 0.070 kg is suspended from it.

(iii) Use your data to determine the force needed to stretch the spring by 1 mm.

gravitational field strength = 9.8 N kg^{-1}

(4 marks)

(b) Arrange the apparatus as shown in **Figure 2**. Note that the load suspended from the string is 0.070 kg.

Figure 2

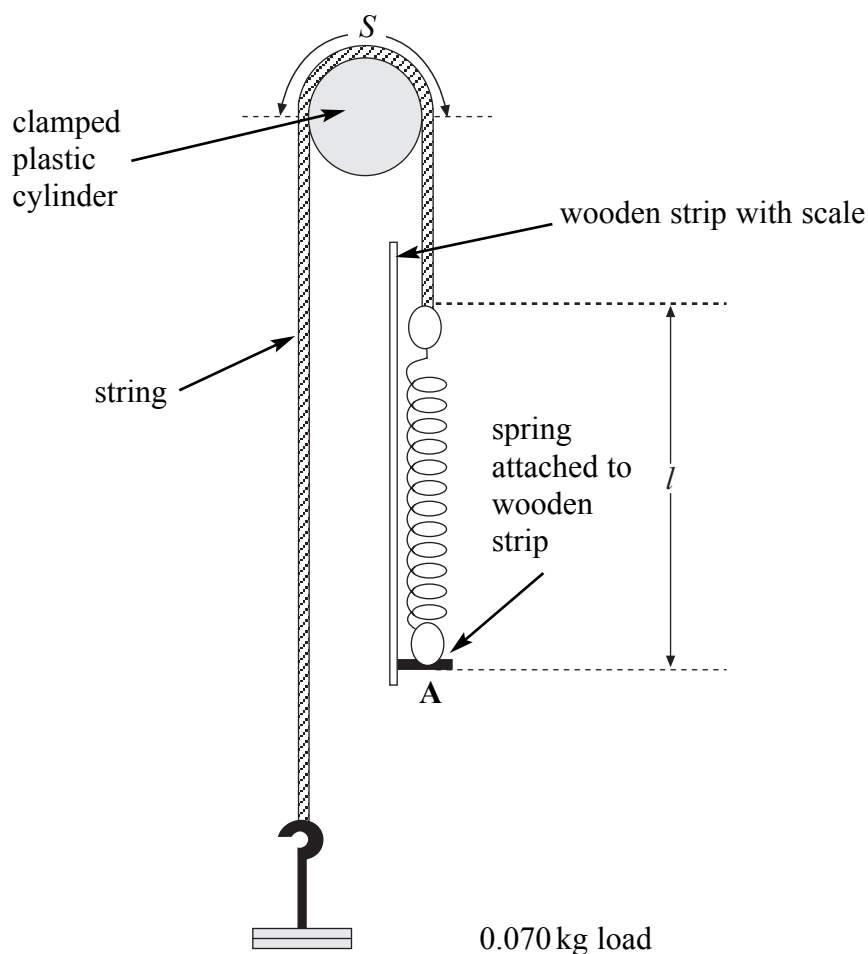

Turn over ►

When the wooden strip is pulled downwards at **A** the spring stretches so that it exerts a force F on the string. You are now going to obtain data to determine how the force F , in N, needed to start the load moving varies with S , the length of string in contact with the plastic cylinder.

The circumference of the cylinder is given on a card near your apparatus. State this value in your answer book.

In the arrangement in **Figure 2** the string is in contact with half the circumference of the plastic cylinder.

- (i) Calculate S for the arrangement in **Figure 2**.
- (ii) You are to stretch the spring and measure, as accurately as possible, the length, l , of the spring when the string just slips on the plastic cylinder and the 0.070 kg load starts to move.

Gradually increase the length of the spring by pulling on the wooden strip.

Do some rough trials and plan how you will measure the length, l , of the spring.

In view of your trials explain briefly why it is important to repeat this measurement.

- (iii) Measure and record the length l , of the spring which just causes the 0.070 kg load to move.
 - (iv) Calculate the extension $(l-l_0)$ of the spring and hence, using your answer to part (a)(iii), calculate the force F , in N, needed to move the load. (6 marks)
- (c) Draw up a table in which to record the corresponding values of S , l , $(l-l_0)$ and F . Also include a column in which to record values for $\ln(F/N)$ i.e. $\log_e(F/N)$.

Repeat the procedure in parts (b)(ii) and (b)(iii) to determine F for at least 5 further values of S . Give your values of S in mm.

Some examples of other arrangements with different values of S are shown in **Figure 3**. Do not use arrangements with more than $1\frac{3}{4}$ turns. (12 marks)

Figure 3

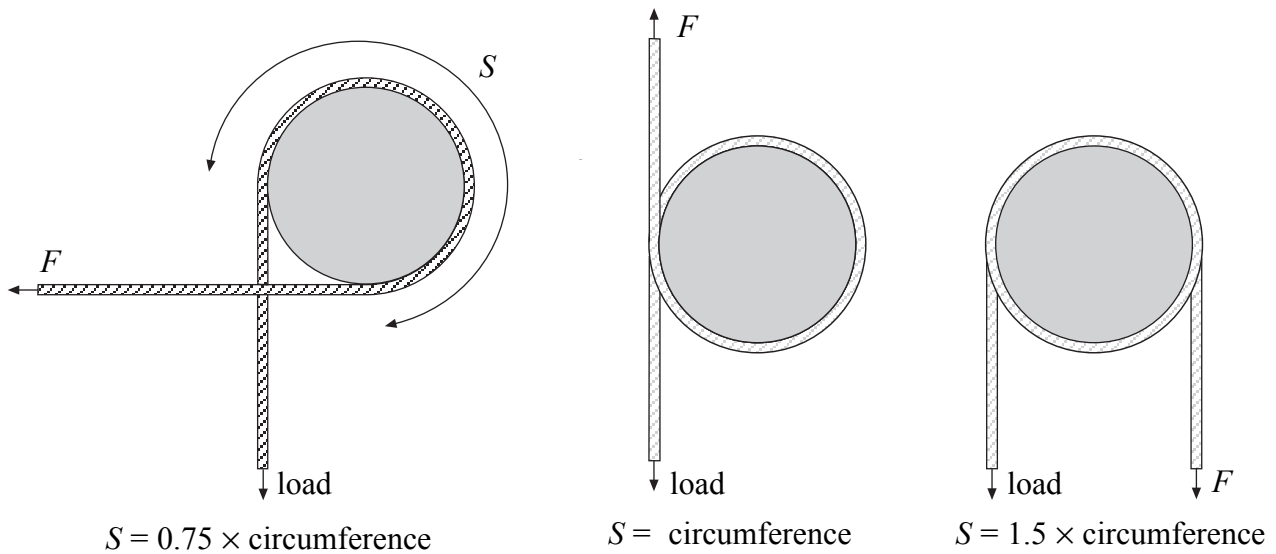

- (d) Plot the graph of $\ln(F/N)$ against S/mm . Draw the best-fit straight line through your plotted points.

(6 marks)

- (e) Theory suggests that the equation representing the relationship between F and S is

$$F = K e^{\frac{\mu S}{R}}$$

where μ is the coefficient of friction for the string and plastic,
 R is the radius of the cylinder in mm,
 and K is a constant.

- (i) Explain whether your data support the theory.
- (ii) Determine a value for μ .
- (iii) Determine a value for K . State the unit for K .

(11 marks)

Turn over ►

Exercise 2

1 You have been provided with the apparatus shown in **Figure 1**.

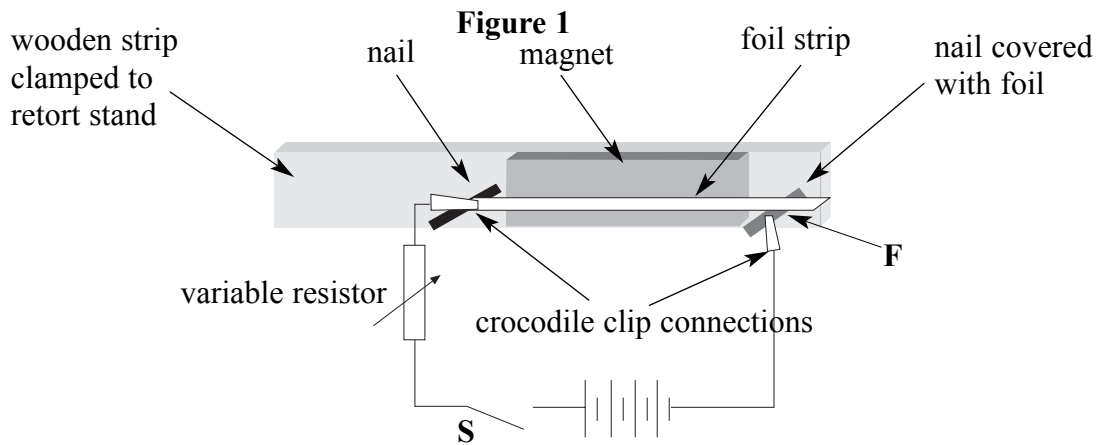

The poles of the magnet are on its largest faces, i.e the face fixed to the wooden strip and the opposite face.

The foil strip should make contact with the foil-covered nail at **F** so that when the switch is closed there is a current in the foil strip.

Close the switch **S** and observe the motion of the strip. If the foil strip does not move, or stops moving, adjusting it slightly should start the motion. If no motion is observed consult your supervisor.

Open the switch when you have made the required observations.

- (a) (i) Describe briefly the motion of the strip. (2 marks)
- (ii) State the factors that affect the magnitude of the force that produces the initial motion. (3 marks)
- (b) Explain why the strip moves in the way you have described in part (a)(i).

Two of the 7 marks are available for the quality of your written communication. (7 marks)

- (c) (i) Close the switch and use the variable resistor to reduce slowly the potential difference across the strip. State the effect this has on the amplitude of the motion. (1 mark)
- (ii) Suggest **two** factors, other than the potential difference across the strip, that you think might have an effect on the amplitude of the motion.

For each factor, state the effect it will have when this factor only is changed in the arrangement. Give a reason for the effect.

Factor 1
Factor 2

(6 marks)

- 2 You are provided with the circuit shown in Figure 2. You have also been provided with a red filter.

Figure 2

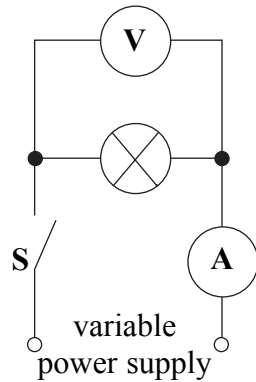
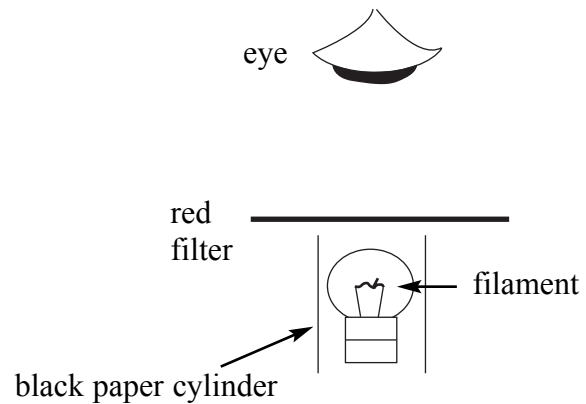

Figure 3



- (a) The red filter transmits light of mean wavelength λ . View the filament of the lamp through the red filter, as shown in **Figure 3**.
- Close switch S.
Starting from a low value gradually increase the potential difference across the lamp and determine the current, I , and potential difference, V , when the lamp is just seen to glow when viewed through the filter.
 - Use your answers to part (a)(i) to calculate a value for the resistance R_{red} of the filament when the lamp just emits the red light transmitted by the filter.
 - Calculate the temperature T_{red} of the filament when it just emits red light using the formula

$$T_{\text{red}} = \frac{R_{\text{red}}}{R} T$$

where R is the resistance of the filament at room temperature T , in K.

The resistance R is given on the card near your apparatus.

You have been provided with a thermometer for measuring room temperature.

(6 marks)

Turn over ►

-
- (b) (i) Explain why the uncertainties in I and V are greater than the smallest changes detectable by the meters. Suggest how you would proceed to obtain more reliable values.
- (ii) State the absolute uncertainties in I and V . Hence determine the percentage uncertainty in the value of T_{red} .

You may ignore any uncertainty in T . The uncertainty in R is given on the card.

- (iii) Suggest why the absolute uncertainty in T is so small that it can be ignored. *(6 marks)*

- (c) It is suggested that the temperature of the filament measured as in part (a) is directly proportional to the mean frequency of the light transmitted by the filter.

Describe how you would extend this experiment to test this suggestion.

You should include in your description:

- any apparatus you would need in addition to that provided
- the procedure you would use, including a brief description of how you would determine the frequency of the transmitted light
- how you would use the measurements that you make to test the suggestion.

Two of the 8 marks are available for the quality of your written communication. *(8 marks)*

General Certificate of Education
June 2006
Advanced Level Examination

**PHYSICS (SPECIFICATION B)
UNIT 6**

PHB6/TN

SUPERVISORS REPORT

When completed by the Supervisor, this Report must be attached firmly to the topmost script, before despatch to the Examiner.

Information from supervisor

Typical potential difference when the filament just glowsV
Typical current when the filament just glows A

Supervisor's Signature.....

Centre Number

Date

Centres may make copies of this Supervisor's Report for attachment to individual scripts where necessary.

There are no notes printed on this page