

Surname		Other Names	
Centre Number		Candidate Number	
Candidate Signature			

Leave blank

General Certificate of Education
January 2006
Advanced Subsidiary Examination



PHYSICS (SPECIFICATION B)
Unit 2 Waves and Nuclear Physics

PHB2

Thursday 12 January 2006 9.00 am to 10.30 am

<p>For this paper you must have:</p> <ul style="list-style-type: none"> • a calculator • a ruler

Time allowed: 1 hour 30 minutes

Instructions

- Use blue or black ink or ball-point pen.
- Fill in the boxes at the top of this page.
- Answer **all** questions.
- Answer the questions in **Section A** and **Section B** in the spaces provided.
- Do all rough work in this book. Cross through any work you do not want marked.
- A *Formulae Sheet* is provided on page 3. Detach this perforated page at the start of the examination.

Information

- The maximum mark for this paper is 75.
- The marks for questions are shown in brackets.
- You are expected to use a calculator where appropriate.
- You are reminded of the need for good English and clear presentation in your answers. Questions 9 and 12(e) should be answered in continuous prose. Quality of Written Communication will be assessed in these answers.

Advice

- You are advised to spend about 30 minutes on **Section A** and about 1 hour on **Section B**.

For Examiner's Use			
Number	Mark	Number	Mark
A		8	
		9	
		10	
		11	
		12	
Total (Column 1) →			
Total (Column 2) →			
TOTAL			
Examiner's Initials			

SECTION A

Answer **all** questions in this section.

There are 24 marks in this section.

1 State the differences in quark structure between a meson and a baryon.

.....
.....
.....
.....

(2 marks)

2 A broadcast of music is transmitted with a bandwidth of 6 kHz.

(a) State the effective frequency range that such a system can transmit.

effective frequency range

(1 mark)

(b) Comment on the quality of music reproduction by such a system compared with the original sound, explaining your answer.

.....
.....
.....
.....
.....

(2 marks)

Detach this perforated page at the start of the examination.

Foundation Physics Mechanics Formulae

$$\text{moment of force} = Fd$$

$$v = u + at$$

$$s = ut + \frac{1}{2}at^2$$

$$v^2 = u^2 + 2as$$

$$s = \frac{1}{2}(u + v)t$$

$$\text{for a spring, } F = k\Delta l$$

$$\text{energy stored in a spring} = \frac{1}{2}F\Delta l = \frac{1}{2}k(\Delta l)^2$$

$$T = \frac{1}{f}$$

Foundation Physics Electricity Formulae

$$I = nAvq$$

$$\text{terminal p.d.} = E - Ir$$

$$\text{in series circuit, } R = R_1 + R_2 + R_3 + \dots$$

$$\text{in parallel circuit, } \frac{1}{R} = \frac{1}{R_1} + \frac{1}{R_2} + \frac{1}{R_3} + \dots$$

$$\text{output voltage across } R_1 = \left(\frac{R_1}{R_1 + R_2} \right) \times \text{input voltage}$$

Waves and Nuclear Physics Formulae

$$\text{fringe spacing} = \frac{\lambda D}{d}$$

$$\text{single slit diffraction minimum } \sin \theta = \frac{\lambda}{b}$$

$$\text{diffraction grating } n\lambda = d \sin \theta$$

$$\text{Doppler shift } \frac{\Delta f}{f} = \frac{v}{c} \text{ for } v \ll c$$

$$\text{Hubble law } v = Hd$$

$$\text{radioactive decay } A = \lambda N$$

Properties of Quarks

Type of quark	Charge	Baryon number
up u	$+\frac{2}{3}e$	$+\frac{1}{3}$
down d	$-\frac{1}{3}e$	$+\frac{1}{3}$
\bar{u}	$-\frac{2}{3}e$	$-\frac{1}{3}$
\bar{d}	$+\frac{1}{3}e$	$-\frac{1}{3}$

Lepton Numbers

Particle	Lepton number L		
	L_e	L_μ	L_τ
e^-	1		
e^+	-1		
ν_e	1		
$\bar{\nu}_e$	-1		
μ^-		1	
μ^+		-1	
ν_μ		1	
$\bar{\nu}_\mu$		-1	
τ^-			1
τ^+			-1
ν_τ			1
$\bar{\nu}_\tau$			-1

Geometrical and Trigonometrical Relationships

$$\text{circumference of circle} = 2\pi r$$

$$\text{area of a circle} = \pi r^2$$

$$\text{surface area of sphere} = 4\pi r^2$$

$$\text{volume of sphere} = \frac{4}{3}\pi r^3$$

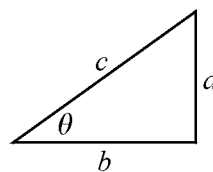

$$\sin \theta = \frac{a}{c}$$

$$\cos \theta = \frac{b}{c}$$

$$\tan \theta = \frac{a}{b}$$

$$c^2 = a^2 + b^2$$

Turn over ►

There are no questions printed on this page

- 3 **Figure 1** shows a graph of displacement against time for two waves **A** and **B**. These waves meet in phase and add to form a resultant wave.

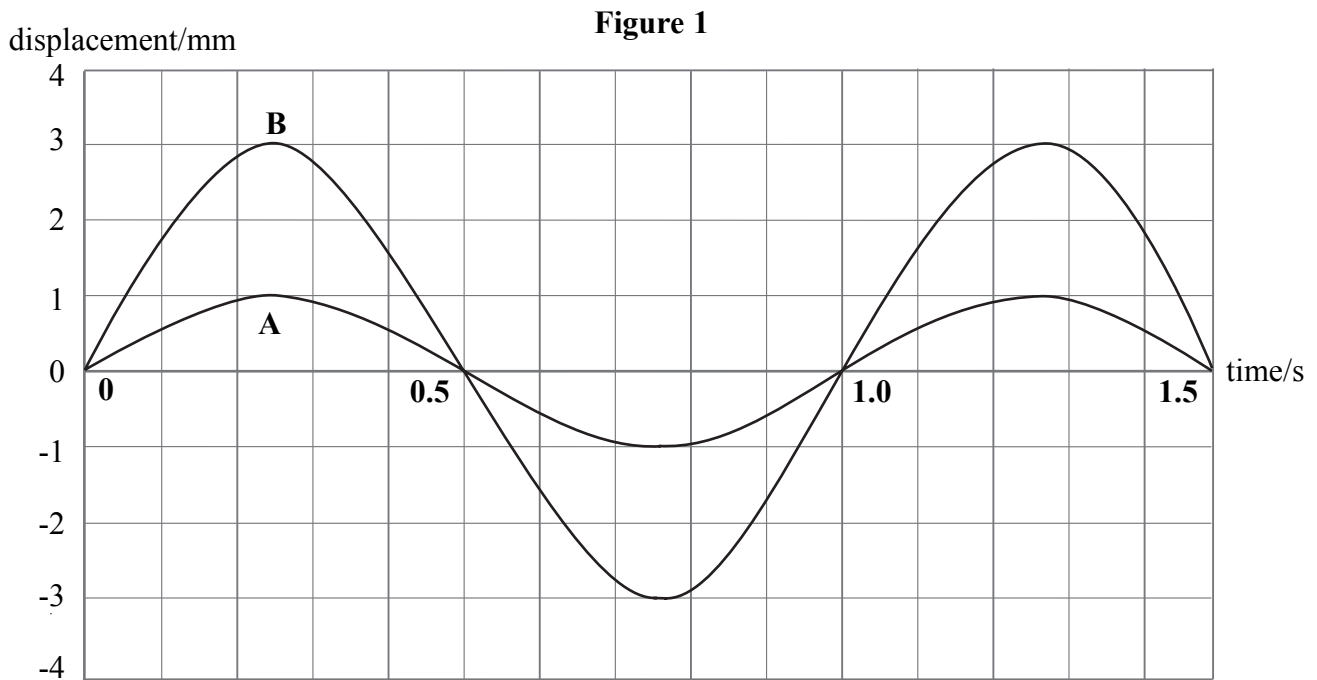

- (a) State the amplitude of the resultant wave.

.....
(1 mark)

- (b) Calculate the ratio

intensity of wave **B** : intensity of wave **A**.

(2 marks)

Turn over ►

- 4 **Figure 2** shows an experimental arrangement in which radio waves from an aerial are incident on a double slit. The waves passing through the slits are received some distance away using a similar aerial. This arrangement produces a current output on a microammeter that is proportional to the resultant intensity of the waves arriving.

Figure 2

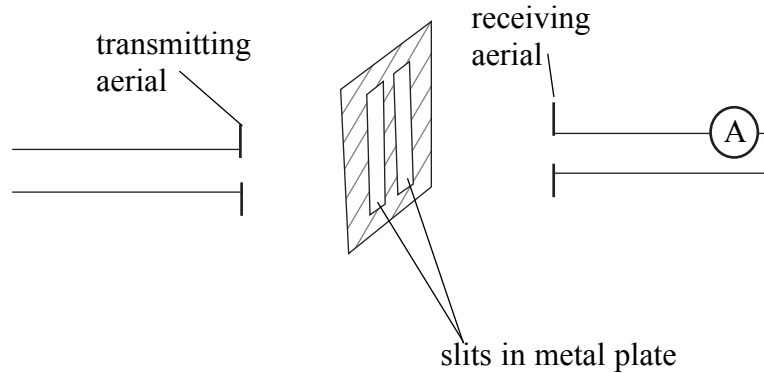

- (a) The slits are 0.080 m apart and the wavelength of the radio waves is 0.025 m. Calculate the 'fringe' spacing that will be observed with the receiving aerial placed 3.0 m from the double slits.

'fringe' spacing
(2 marks)

- (b) The receiving aerial is placed at a point of maximum amplitude but is then rotated through 90° as shown in **Figure 3**.

Figure 3

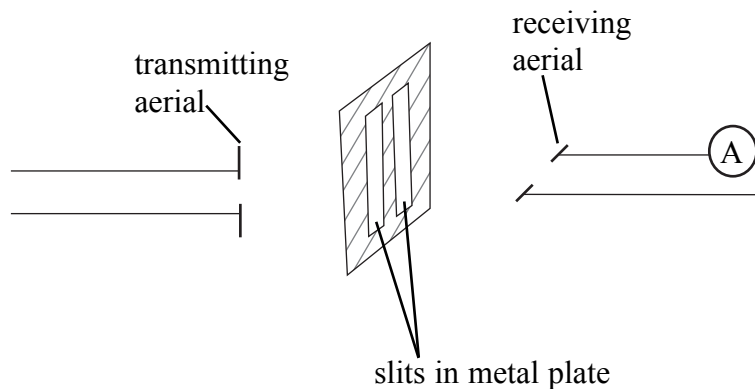

The reading falls to zero. Explain this observation and state what it allows you to deduce about radio waves.

.....

.....

.....

.....

(2 marks)

- 5 **Figure 4** shows a violin string. One way to produce a musical note is to pull the centre of the string to one side and then release it quickly.

Figure 4

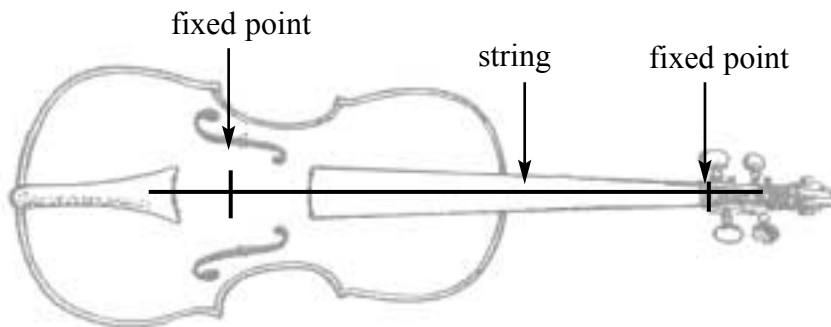

- (a) Draw on **Figure 4** the fundamental standing wave that will appear on the string when the note is sounding. (1 mark)
- (b) (i) Sketch on **Figure 5** the standing wave that corresponds to a frequency of three times that of the fundamental.

Figure 5

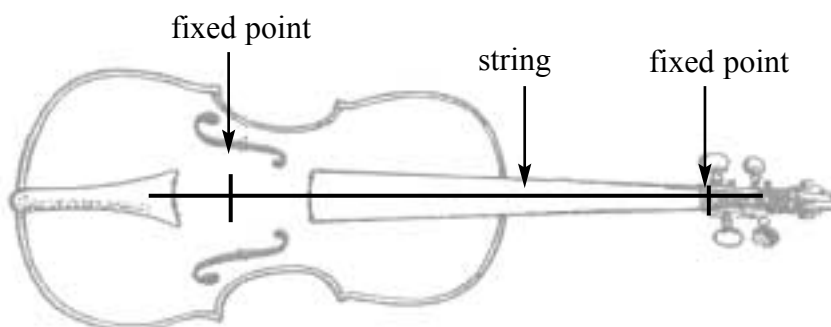

Turn over ►

- (ii) State the name given to points on the standing wave where there is no vibration of the string.

.....
(2 marks)

- (c) Children often learn to play the violin on a small instrument with shorter strings. These shorter strings have to produce the same fundamental frequencies as those on the full-size instrument. State **two** ways in which this can be achieved.

.....
.....
.....
.....
.....
.....
.....
(2 marks)

6 A diffraction grating has 940 lines per mm.

- (a) Calculate the distance between adjacent lines on the grating.

distance between lines
(1 mark)

- (b) Monochromatic light is incident on the grating and a second-order spectral line is formed at an angle of 55° from the normal to the grating. Calculate the wavelength of the light.

wavelength
(3 marks)

- 7 The table shows some of the results from an experiment in which measurements were made of the count-rate at various distances from a source of gamma rays.

distance from source to detector/m	0.5	1.0	2.0
uncorrected count-rate/counts per minute		182	
corrected count-rate/counts per minute	592	148	

Complete the blank spaces in the table with the values you would expect.

(3 marks)

24

Turn over for Section B

Turn over ▶

SECTION B

Answer **all** questions in this section.

- 8** A speed camera uses the Doppler effect to measure the speed of a moving car. An electromagnetic wave is directed towards the car where the wave undergoes a Doppler shift before being returned to the camera. When the wave returns to the camera, the new frequency is measured.

- (a) One type of speed camera transmits a signal of frequency 2.1×10^{10} Hz. State the region of the electromagnetic spectrum to which this wave belongs.

.....
(1 mark)

- (b) The car is moving towards the speed camera. Explain why the frequency measured by an observer in the car differs from the frequency emitted by the speed camera. State whether the observed frequency is higher or lower than the original.

.....
.....
.....
(2 marks)

- (c) The car has a speed towards the camera of 65 km/hour. Calculate the shift in frequency measured by an observer in the car.

$$\text{speed of electromagnetic waves } c = 3.0 \times 10^8 \text{ m s}^{-1}$$

frequency shift
(3 marks)

- (d) State the wave property that causes the wave to return from the car to the camera.

.....
(1 mark)

- 10 (a) Carbon-14 (${}^{14}_6\text{C}$) decays with the emission of a beta particle to form nitrogen (N).

Nitrogen has a proton number of 7. Write down the full nuclear equation that describes this decay.

(3 marks)

- (b) A sample of pure ${}^{14}_6\text{C}$ contains 6.3×10^{19} carbon atoms each with a decay probability of $3.8 \times 10^{-12} \text{ s}^{-1}$.

- (i) State the S.I. unit of activity.

.....

- (ii) Calculate the initial activity of the sample.

initial activity

(3 marks)

- (c) All nuclei of carbon-14 ($^{14}_6\text{C}$) have the same decay probability.
Explain how this statement accounts for the observation that the number, N , of radioactive carbon atoms in the sample varies with time, t , as shown in **Figure 6**.

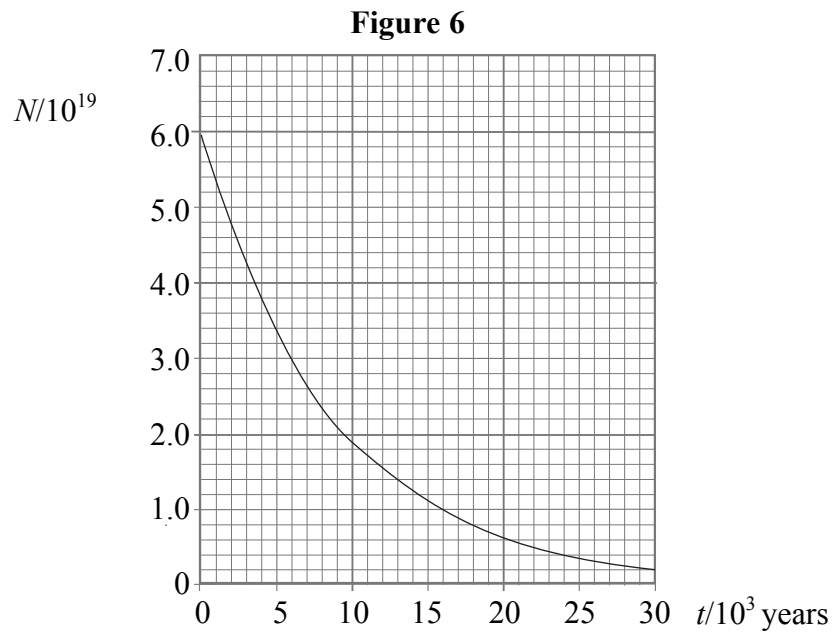

.....

.....

.....

.....

.....

.....

.....

.....

.....

.....

.....

(4 marks)

- 11** **Figure 7** shows the displacement of particles in an ultrasound wave at different distances from the source at a particular time. The wave travels at 3200 m s^{-1} .

Figure 7

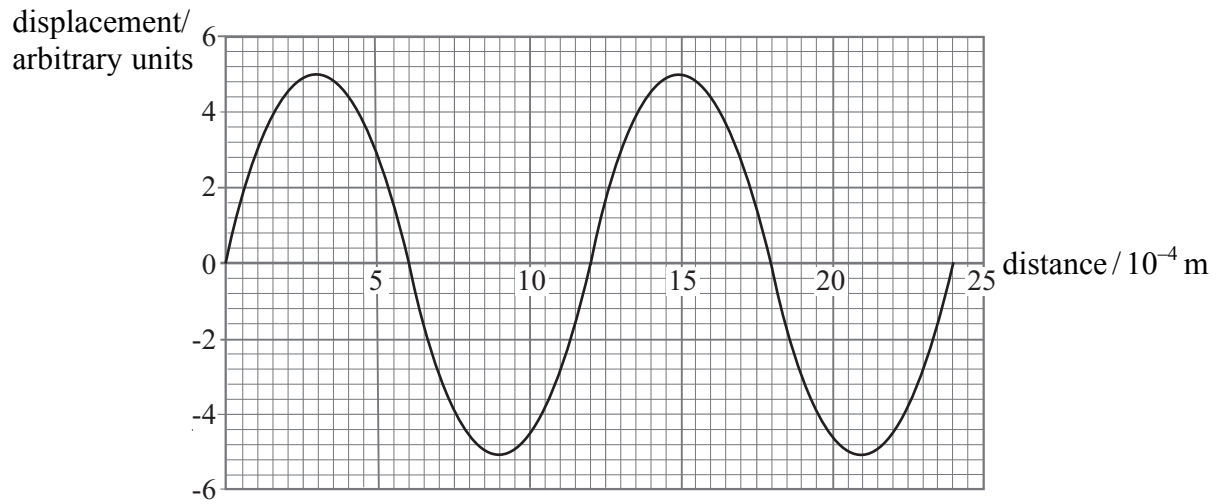

- (a) (i) Use the graph to find the wavelength of the wave in **Figure 7**.

wavelength

- (ii) Calculate the frequency of the ultrasound wave.

frequency
(3 marks)

- (b) One industrial use for ultrasound waves is to detect flaws inside a metal block. **Figure 8a** shows the arrangement in which the waves are fired downwards in short pulses from a transmitter. **Figure 8b** shows the amplitudes of the initial pulse and the reflected signals recorded by the receiver. You may assume that there is no reflected pulse received from the upper surface of the block.

Figure 8a

transmitter receiver

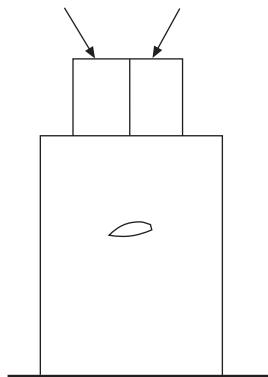
**Figure 8b**

amplitude/arbitrary units

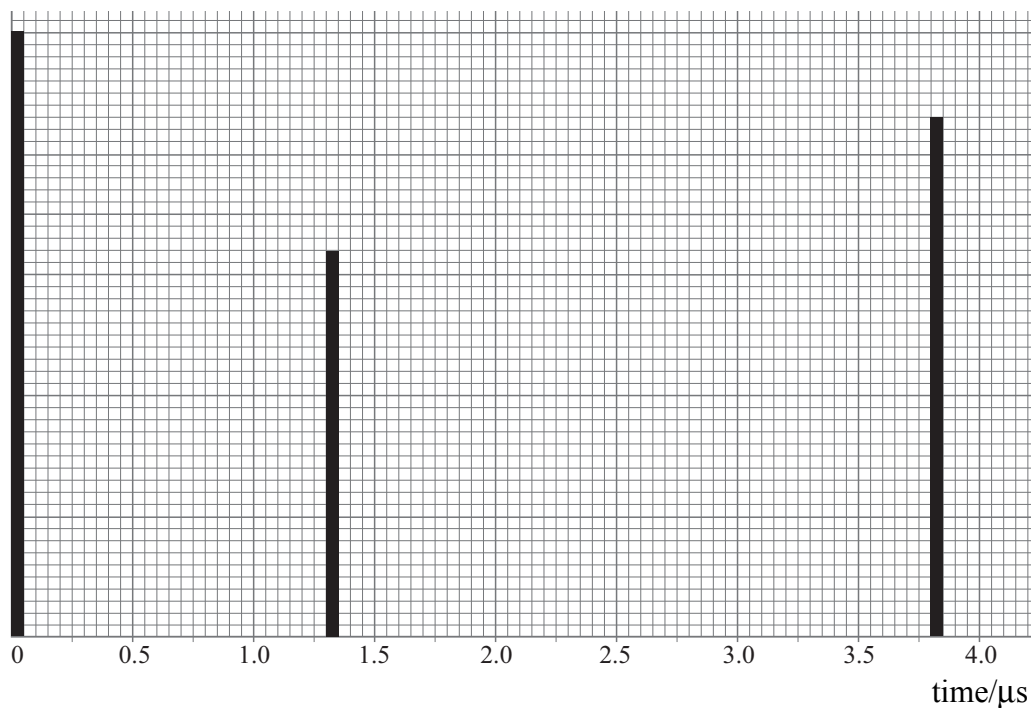

The ultrasound wave travels at 3200 m s^{-1} . Use data from **Figure 8b** to calculate the distance of the flaw below the top of the block.

distance

(3 marks)

Turn over ▶

12 Radar waves are used to study the surface structure of the Antarctic ice-sheet. **Figure 9** shows some of the successive peaks of a wave (the wavefronts) moving from an aircraft to the ice as they meet the air–ice interface.

- (a) The wave is partially transmitted and partially reflected at the air–ice interface. Draw on **Figure 9** the subsequent positions of the wave peaks after they have reached the ice surface.

Figure 9

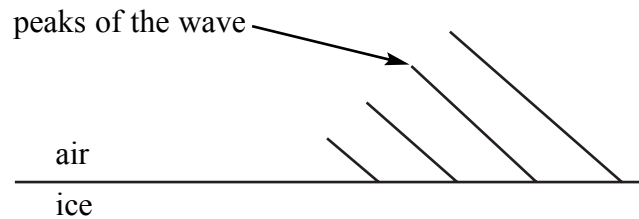

(4 marks)

Figure 10 shows a similar technique in which the radar signal is transmitted vertically downwards from the aircraft.

Figure 10

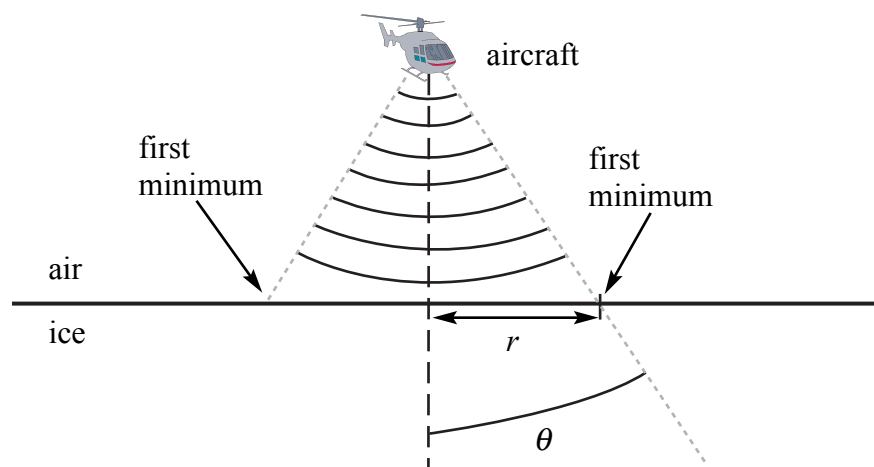

The wavelength of the radar wave is 0.045 m and it emerges from the aircraft through an aperture of diameter 0.62 m where it is diffracted.

- (b) (i) Calculate the angle θ , to the vertical, at which a first minimum of intensity of the diffracted beam occurs.

angle θ

- (ii) The aircraft flies at a height of 500 m above the ice surface. Calculate the radius, r , of the circle over which the central maximum of the diffracted beam extends.

radius

(4 marks)

- (c) The radar signal is reflected back to the aircraft by the ice and is received through another aperture in the base of the aircraft. The resolution of the system can be improved by flying closer to the ice. State **two** further ways in which the resolution of the receiving system can be improved.

method 1

.....

method 2

.....

(2 marks)

- (d) The data are transmitted from the aircraft back to an Antarctic base station in real time. Complete the block diagram of a communication transmissions system on the aircraft that could be used to achieve this.

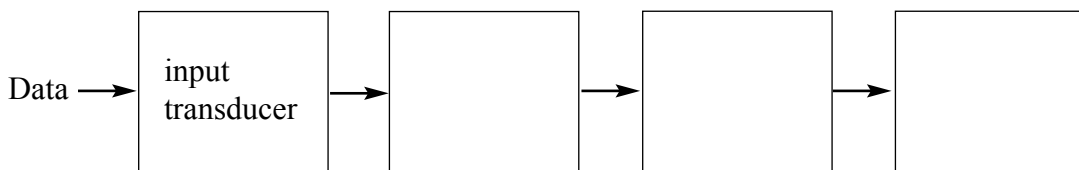

(3 marks)

Question 12 continues on the next page

Turn over ▶

There are no questions printed on this page

There are no questions printed on this page