

Surname		Other Names	
Centre Number		Candidate Number	
Candidate Signature			

Leave blank

General Certificate of Education
June 2005
Advanced Level Examination



PHYSICS (SPECIFICATION B)
Unit 5 Fields and their Applications

PHB5

Monday 27 June 2005 Afternoon Session

In addition to this paper you will require:

- a calculator;
- a ruler.

For Examiner's Use			
Number	Mark	Number	Mark
1			
2			
3			
4			
5			
6			
7			
8			
9			
10			
11			
Total (Column 1)	→		
Total (Column 2)	→		
TOTAL			
Examiner's Initials			

Time allowed: 2 hours

Instructions

- Use blue or black ink or ball-point pen.
- Fill in the boxes at the top of this page.
- Answer **all** questions in the spaces provided.
- Do all rough work in this book. Cross through any work you do not want marked.
- All working must be shown, otherwise you may lose marks.
- *Formulae Sheets* are provided on pages 3 and 4. Detach this perforated page at the start of the examination.
- Pages 15 and 16 form a perforated sheet which should be detached from this booklet. Use this sheet to help you to answer Questions 6, 7, 8, 9, 10 and 11.

Information

- The maximum mark for this paper is 100.
- Mark allocations are shown in brackets.
- Marks are awarded for units in addition to correct numerical answers and for the use of appropriate numbers of significant figures.
- You will be expected to use a calculator where appropriate.
- You will be assessed on your ability to use an appropriate form and style of writing, to organise relevant information clearly and coherently, and to use specialist vocabulary where appropriate.
- The degree of legibility of your handwriting and the level of accuracy of your spelling, punctuation and grammar will also be taken into account.

Answer **all** questions in the spaces provided.

Total for this question: 13 marks

- 1 (a) State the law that governs the magnitude of the force between two point masses.

.....

.....

.....

.....

(2 marks)

- (b) The table shows how the gravitational potential varies for three points above the centre of the Sun.

distance from centre of Sun/ 10^8 m	gravitational potential/ 10^{10} J kg $^{-1}$
7.0 (surface of sun)	-19
16	-8.3
35	-3.8

- (i) Show that the data suggest that the potential is inversely proportional to the distance from the centre of the Sun.

(2 marks)

- (ii) Use the data to determine the gravitational field strength near the surface of the Sun.

(3 marks)

Detach this perforated page at the start of the examination.

Foundation Physics Mechanics Formulae

$$\text{moment of force} = Fd$$

$$v = u + at$$

$$s = ut + \frac{1}{2}at^2$$

$$v^2 = u^2 + 2as$$

$$s = \frac{1}{2}(u + v)t$$

$$\text{for a spring, } F = k\Delta l$$

$$\text{energy stored in a spring} = \frac{1}{2}F\Delta l = \frac{1}{2}k(\Delta l)^2$$

$$T = \frac{1}{f}$$

Foundation Physics Electricity Formulae

$$I = nAvq$$

$$\text{terminal p.d.} = E - Ir$$

$$\text{in series circuit, } R = R_1 + R_2 + R_3 + \dots$$

$$\text{in parallel circuit, } \frac{1}{R} = \frac{1}{R_1} + \frac{1}{R_2} + \frac{1}{R_3} + \dots$$

$$\text{output voltage across } R_1 = \left(\frac{R_1}{R_1 + R_2} \right) \times \text{input voltage}$$

Waves and Nuclear Physics Formulae

$$\text{fringe spacing} = \frac{\lambda D}{d}$$

$$\text{single slit diffraction minimum } \sin \theta = \frac{\lambda}{b}$$

$$\text{diffraction grating } n\lambda = d \sin \theta$$

$$\text{Doppler shift } \frac{\Delta f}{f} = \frac{v}{c} \text{ for } v \ll c$$

$$\text{Hubble law } v = Hd$$

$$\text{radioactive decay } A = \lambda N$$

Properties of Quarks

Type of quark	Charge	Baryon number
up u	$+\frac{2}{3}e$	$+\frac{1}{3}$
down d	$-\frac{1}{3}e$	$+\frac{1}{3}$
\bar{u}	$-\frac{2}{3}e$	$-\frac{1}{3}$
\bar{d}	$+\frac{1}{3}e$	$-\frac{1}{3}$

Lepton Numbers

Particle	Lepton number L		
	L_e	L_μ	L_τ
e^-	1		
e^+	-1		
ν_e	1		
$\bar{\nu}_e$	-1		
μ^-		1	
μ^+		-1	
ν_μ		1	
$\bar{\nu}_\mu$		-1	
τ^-			1
τ^+			-1
ν_τ			1
$\bar{\nu}_\tau$			-1

Geometrical and Trigonometrical Relationships

$$\text{circumference of circle} = 2\pi r$$

$$\text{area of a circle} = \pi r^2$$

$$\text{surface area of sphere} = 4\pi r^2$$

$$\text{volume of sphere} = \frac{4}{3}\pi r^3$$

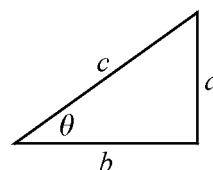

$$\sin \theta = \frac{a}{c}$$

$$\cos \theta = \frac{b}{c}$$

$$\tan \theta = \frac{a}{b}$$

$$c^2 = a^2 + b^2$$

Turn over ►

Detach this perforated page at the start of the examination.

Circular Motion and Oscillations

$$v = r\omega$$

$$a = -(2\pi f)^2 x$$

$$x = A \cos 2\pi ft$$

$$\text{maximum } a = (2\pi f)^2 A$$

$$\text{maximum } v = 2\pi fA$$

$$\text{for a mass-spring system, } T = 2\pi\sqrt{\frac{m}{k}}$$

$$\text{for a simple pendulum, } T = 2\pi\sqrt{\frac{l}{g}}$$

Fields and their Applications

$$\text{uniform electric field strength, } E = \frac{V}{d} = \frac{F}{Q}$$

$$\text{for a radial field, } E = \frac{kQ}{r^2}$$

$$k = \frac{1}{4\pi\epsilon_0}$$

$$g = \frac{F}{m}$$

$$g = \frac{GM}{r^2}$$

$$\text{for point masses, } \Delta E_p = GM_1 M_2 \left(\frac{1}{r_1} - \frac{1}{r_2} \right)$$

$$\text{for point charges, } \Delta E_p = kQ_1 Q_2 \left(\frac{1}{r_1} - \frac{1}{r_2} \right)$$

$$\text{for a straight wire, } F = BIl$$

$$\text{for a moving charge, } F = BQv$$

$$\phi = BA$$

$$\text{induced emf} = \frac{\Delta(N\phi)}{t}$$

$$E = mc^2$$

Temperature and Molecular Kinetic Theory

$$T/\text{K} = \frac{(pV)_T}{(pV)_{tr}} \times 273.16$$

$$pV = \frac{1}{3} Nm \langle c^2 \rangle$$

$$\text{energy of a molecule} = \frac{3}{2} kT$$

Heating and Working

$$\Delta U = Q + W$$

$$Q = mc\Delta\theta$$

$$Q = ml$$

$$P = Fv$$

$$\text{efficiency} = \frac{\text{useful power output}}{\text{power input}}$$

$$\text{work done on gas} = p\Delta V$$

$$\text{work done on a solid} = \frac{1}{2} F\Delta l$$

$$\text{stress} = \frac{F}{A}$$

$$\text{strain} = \frac{\Delta l}{l}$$

$$\text{Young modulus} = \frac{\text{stress}}{\text{strain}}$$

Capacitance and Exponential Change

$$\text{in series, } \frac{1}{C} = \frac{1}{C_1} + \frac{1}{C_2}$$

$$\text{in parallel, } C = C_1 + C_2$$

$$\text{energy stored by capacitor} = \frac{1}{2} QV$$

$$\text{parallel plate capacitance, } C = \frac{\epsilon_0 \epsilon_r A}{d}$$

$$Q = Q_0 e^{-t/RC}$$

$$\text{time constant} = RC$$

$$\text{time to halve} = 0.69 RC$$

$$N = N_0 e^{-\lambda t}$$

$$A = A_0 e^{-\lambda t}$$

$$\text{half-life, } t_{\frac{1}{2}} = \frac{0.69}{\lambda}$$

Momentum and Quantum Phenomena

$$Ft = \Delta(mv)$$

$$E = hf$$

$$hf = \Phi + E_{k(\max)}$$

$$hf = E_2 - E_1$$

$$\lambda = \frac{h}{mv}$$

- (iii) Calculate the change in gravitational potential energy needed for the Earth to escape from the gravitational attraction of the Sun.

$$\begin{aligned} \text{mass of the Earth} &= 6.0 \times 10^{24} \text{ kg} \\ \text{distance of Earth from centre of Sun} &= 1.5 \times 10^{11} \text{ m} \end{aligned}$$

(3 marks)

- (iv) Calculate the kinetic energy of the Earth due to its orbital speed around the Sun and hence find the minimum energy that would be needed for the Earth to escape from its orbit. Assume that the Earth moves in a circular orbit.

(3 marks)

13

TURN OVER FOR THE NEXT QUESTION

Turn over ▶

Total for this question: 13 marks

2 (a) Eddy currents in the cores of transformers are one cause of inefficiency in transformers.

(i) Explain what is meant by an eddy current, how eddy currents are produced in transformer cores and why they lead to inefficient operation of the transformer.

Two of the 6 marks for this question are available for the quality of your written communication.

.....

.....

.....

.....

.....

.....

.....

.....

.....

.....

.....

.....

.....

.....

.....

.....

.....

.....

.....

.....

.....

.....

(6 marks)

(ii) Explain how the design of a transformer minimises the inefficiency due to eddy currents.

.....

.....

.....

.....

(2 marks)

- (b) **Figure 1** shows a laboratory arrangement for demonstrating the operation of a transformer.

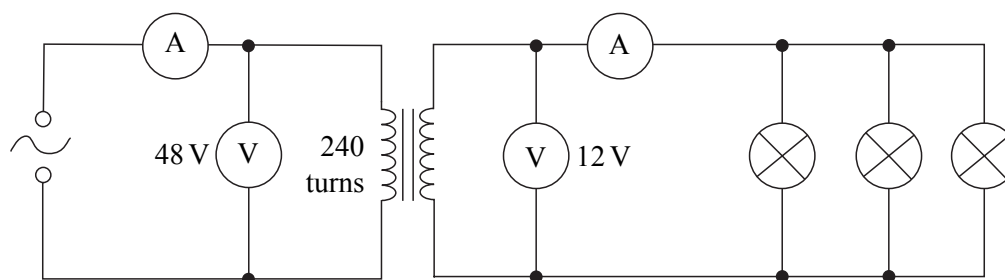

Figure 1

The supply voltage was adjusted until the three 12 V, 36 W lamps operated normally. The voltmeter readings are shown on **Figure 1**. The efficiency of the transformer was 100%.

Calculate:

- (i) the reading of the ammeter in the secondary circuit;

(2 marks)

- (ii) the reading of the ammeter in the primary circuit;

(2 marks)

- (iii) the number of turns on the secondary coil of the transformer.

(1 mark)

Total for this question: 10 marks

- 3 A student set up the apparatus shown in **Figure 2** in an attempt to investigate a method of converting energy from gravitational potential energy to energy stored in a capacitor.

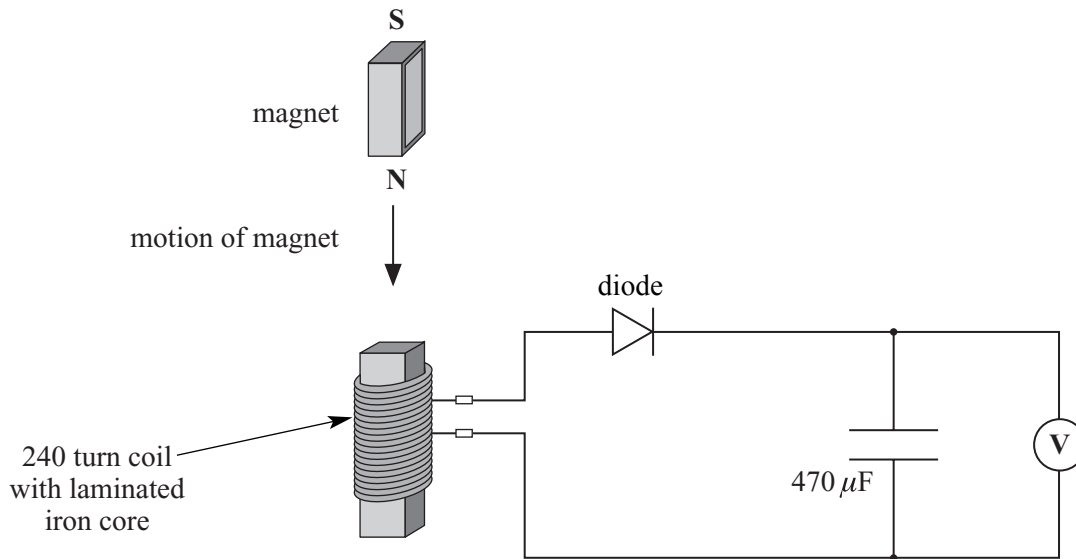

Figure 2

When the magnet fell 0.15 m onto the iron-core the potential difference across the capacitor increased from 0 to 0.30 V.

- (a) The falling magnet produced a maximum potential difference of 1.1 V at the terminals of the 240 turn coil.
- (i) Calculate the maximum rate of change of flux through the coil.

(2 marks)

- (ii) Explain why the potential difference across the capacitor was lower than the potential difference produced at the terminals of the coil.

.....

(1 mark)

- (iii) Explain why no potential difference is recorded across the capacitor when the experiment is repeated with the poles of the magnet reversed.

.....

.....

.....

.....

.....

(2 marks)

- (b) The magnet had a mass of 0.025 kg and fell 0.15 m. The maximum potential difference recorded across the capacitor was 0.30 V.

Calculate the efficiency of the conversion of gravitational potential energy of the magnet to energy stored in the capacitor. Show each stage of your calculation clearly.

$$\text{gravitational field strength} = 9.8 \text{ N kg}^{-1}$$

(5 marks)

10

TURN OVER FOR THE NEXT QUESTION

Turn over ▶

Total for this question: 13 marks

- 4 Americium-241 ($^{241}_{95}\text{Am}$) is a common laboratory source of alpha radiation. It decays spontaneously to neptunium (Np) with a decay constant of $4.8 \times 10^{-11} \text{ s}^{-1}$.

A school laboratory source has an activity due to the presence of americium of $3.7 \times 10^4 \text{ Bq}$ when purchased.

$$\begin{aligned} \text{Avogadro constant} &= 6.0 \times 10^{23} \text{ mol}^{-1} \\ \text{one year} &= 3.2 \times 10^7 \text{ s} \end{aligned}$$

- (a) (i) Calculate the half-life, in years, of americium-241.

(2 marks)

- (ii) Calculate the number of radioactive americium atoms in the laboratory source when it was purchased.

(2 marks)

- (iii) Calculate the activity of the americium in the laboratory source 50 years after being purchased.

(3 marks)

- (iv) Suggest why the actual activity of the sources is likely to be greater than your answer to part (iii).

.....
.....

(1 mark)

- (b) (i) Use the following data to deduce the energy released in the decay of one americium-241 nucleus.

mass of americium-241 nucleus	=	4.00171×10^{-25} kg
mass of an alpha particle	=	0.06644×10^{-25} kg
mass of neptunium nucleus	=	3.93517×10^{-25} kg
speed of electromagnetic radiation in free space	=	3.00×10^8 m s ⁻¹

(3 marks)

- (ii) Explain what is meant by *decays spontaneously* and how consideration of the masses of particles involved in a proposed decay helps in deciding whether the decay is possible.

.....

.....

.....

.....

.....

.....

.....

.....

(2 marks)

Total for this question: 17 marks

- 5 **Figure 3** shows a particle **P** with charge $+6.4 \times 10^{-19} \text{ C}$ about to enter a region where there is a uniform electric field of strength $2.0 \times 10^4 \text{ N C}^{-1}$. **Figure 4** shows the same charged particle about to enter a region where there is a uniform magnetic field of flux density 0.17 T directed into the paper.

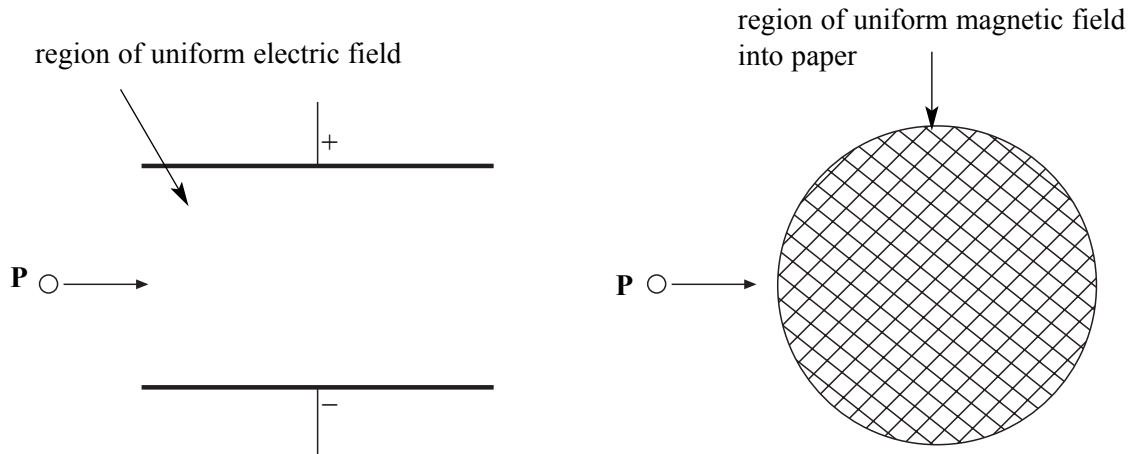

Figure 3

Figure 4

- (a) Sketch on **Figure 3** and **Figure 4** the paths taken by the particle when in each field. (2 marks)

- (b) (i) State what is meant by *uniform electric field strength*.

.....

(2 marks)

- (ii) The separation of the plates in **Figure 3** is 0.045 m . Calculate the potential difference between the plates.

(2 marks)

- (c) (i) Calculate the magnitude of the force on the particle when it is in the electric field.

(2 marks)

- (ii) Calculate the initial velocity of the charged particle for which the magnitude of the force on the particle is the same in each field.

(2 marks)

- (d) Explain why the speed of the particle changes in one of the above situations but remains constant in the other.

Two of the 6 marks for this questions are available for the quality of your written communication.

.....

.....

.....

.....

.....

.....

.....

.....

.....

.....

.....

.....

.....

.....

.....

.....

.....

.....

.....

.....

.....

.....

(7 marks)

The passage for answering Questions 6 to 11 is printed on pages 15-16. Detach the pages and read the passage before answering the questions.

Total for this question: 6 marks

6 Calculate:

(a) the engine thrust produced due to the emission of the exhaust gases;

(2 marks)

(b) the total energy removed from the exhaust gases by the cooling water every second;

(2 marks)

(c) the temperature rise of the cooling water during its flow through the heat exchanger.

(2 marks)

6

Testing Aircraft Engines

Aircraft engines are subjected to rigorous testing to ensure that they perform efficiently and reliably at high altitude. To test the engine it is mounted in an 'air-house' where air pressure, air-speed and temperature can be adjusted to high altitude conditions. The conditions in the air-house need to be carefully monitored.

When operating one jet engine, 270 kg of exhaust gases are emitted each second at a speed of 2000 km h^{-1} and the exhaust gases reach a temperature of 1800°C . These gases have to be cooled to 50°C before they go from the air-house to the next part of the test area. For this purpose 96 km of hollow tube is used as a huge heat exchanger through which $8.0 \times 10^6 \text{ kg}$ of cooling water is pumped every hour.

The air pressure in the air-house can be monitored by two types of transducer. **Figure 5** shows the principle of a strain gauge transducer.

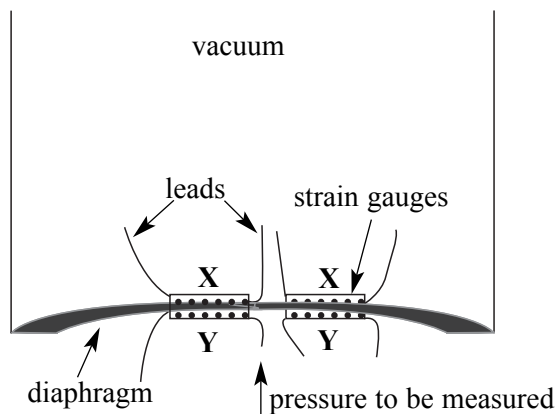

Figure 5

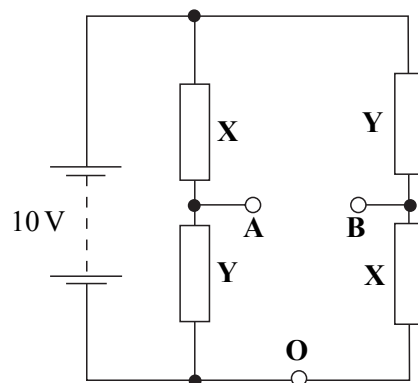

Figure 6

Strain gauges are fixed on each side of a flexible diaphragm. Strain gauges are made of resistive material that becomes longer and thinner when the gauges are stretched. When the pressure increases the movement of the diaphragm causes the resistances of strain gauges X and Y to change. The strain gauges are connected in the circuit shown in **Figure 6**. Any change in pressure causes the voltage between A and B to change and the transducer is calibrated so that the air pressure can be measured.

The other type of pressure sensor is based on the resonance of a vibrating wire. The wire is in a magnetic field produced by a coil, as shown in **Figure 7**.

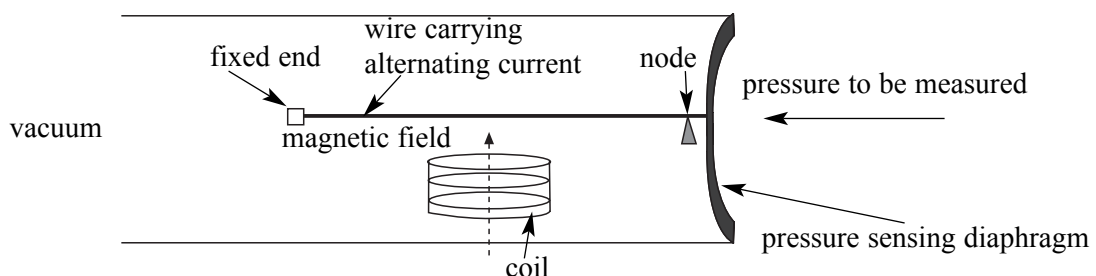

Figure 7

The wire carries an alternating current which causes the wire to undergo forced oscillations and by varying the frequency of the alternating current the resonant frequency can be measured. When the pressure changes the pressure sensing diaphragm moves. This changes the resonant frequency of the wire due to a change in tension of the wire. The change in resonant frequency depends on the change in pressure and the system electronics enables the new pressure to be measured.

All thermometers depend on the variation of a physical quantity with temperature. The air-house temperature is monitored using either resistance thermometers that depend on the variation of the resistance of a platinum wire with temperature, or thermocouples. A thermocouple produces an emf that varies with temperature. Typically a thermocouple has an emf of 11 mV at the triple point of water and this emf increases at a rate of $40 \mu\text{V K}^{-1}$ as temperature rises. One problem met when using any thermometer is *thermal inertia* which means that a thermometer needs a finite time to react to changes in temperature.

The temperatures and pressures are monitored at different points in the air-house as are the strains produced on different parts of the engine. As many as ten signals may be monitored simultaneously and during the test run thousands of different measurements are recorded for a single engine. This requires computer-controlled data gathering and handling. So that the signals can be handled by a single computer input port they are multiplexed after being amplified and digitised. So that the measurements are accurately monitored, it is important that the signal is not degraded in the cable between the test site and the control room.

Icing experiments are also performed simulating a landing from about 5000 m in arctic conditions. As shown schematically in **Figure 8**, an uneven distribution of ice on the air-intake fan blades of a jet engine causes an unbalanced centripetal force. The fan blades rotate at speeds as high as 9000 revolutions per minute so that even a small lump of ice 0.50 m from the axis of rotation can produce an unbalanced force on the axle of the turbine in excess of 40 kN.

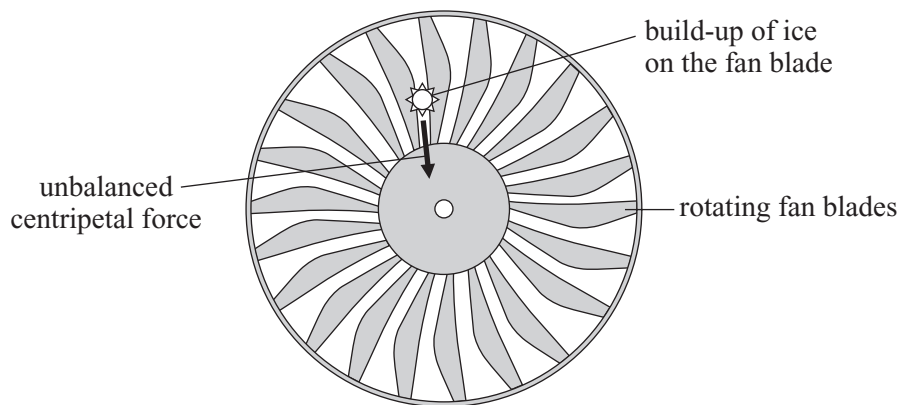

Figure 8

As the fan blades rotate, severe vibrations can be set up which will ultimately damage the engine. By performing detailed tests, operating procedures can be designed to eliminate, as far as possible, the problems caused by icing.

Additional data needed when answering the questions

specific heat capacity of the exhaust gases = $990 \text{ J kg}^{-1} \text{ K}^{-1}$
 specific heat capacity of water = $4200 \text{ J kg}^{-1} \text{ K}^{-1}$

Total for this question: 7 marks

- 7 (a) State and explain how you would expect the resistance of the strain gauges labelled **X** to change when the pressure increases.

.....

.....

.....

.....

.....

.....

(3 marks)

- (b) The strain gauges in **Figure 6** all have a resistance of $48\ \Omega$ when the pressure is normal atmospheric pressure. In one test a pressure change causes the resistance of each resistor **X** to increase by $3\ \Omega$ and the resistance of each resistor **Y** to increase by $1\ \Omega$. The supply in **Figure 6** has negligible internal resistance.

Calculate:

- (i) the voltage between **A** and **O** when there is normal atmospheric pressure;

(1 mark)

- (ii) the voltage between **A** and **O** when the pressure changes;

(2 marks)

- (iii) the voltage between **A** and **B** when the pressure changes.

(1 mark)

7

Turn over ▶

Total for this question: 8 marks

- 8** (a) Explain why the wire in **Figure 7** undergoes forced oscillations when it carries an alternating current.

.....
.....
.....
.....
.....
.....

(3 marks)

- (b) (i) State the condition necessary for the wire to resonate.

.....
.....

(1 mark)

- (ii) State the factors other than the tension in the wire that affect the resonant frequency.

.....
.....

(2 marks)

- (iii) State and explain how the resonant frequency of the wire changes when the pressure increases.

.....
.....
.....
.....

(2 marks)

—
8

Total for this question: 5 marks

- 9 (a) Calculate the emf produced when the thermocouple (lines 24 to 26) is measuring the temperature of the exhaust gases. Assume that the variation of emf with temperature is linear.

(3 marks)

- (b) State **two** factors in the design of thermometers that determine their ‘thermal inertia’ (lines 26 to 27).

.....
.....
.....

(2 marks)

5

TURN OVER FOR THE NEXT QUESTION

Turn over ▶

Total for this question: 3 marks

10 Explain what is meant by

(a) *multiplexed* (line 32);

.....
.....
.....
.....

(2 marks)

(b) *degraded* (line 33).

.....
.....

(1 mark)

Total for this question: 5 marks

11 (a) Calculate the mass of the lump of ice 0.50 m from the axis of rotation that would produce an unbalanced force of 40 kN when the fan blades are rotating at maximum speed (lines 37 to 39).

(3 marks)

(b) Explain how the ‘severe vibrations’, mentioned in line 40, occur.

.....
.....
.....
.....

(2 marks)

3

5

END OF QUESTIONS