

Centre Number						Candidate Number					
Surname						Other Names					
<b>Notice to Candidate.</b> The work you submit for assessment must be your own. If you copy from someone else or allow another candidate to copy from you, or if you cheat in any other way, you may be disqualified.											
<b>Candidate Declaration.</b> I have read and understood the Notice to Candidate and can confirm that I have produced the attached work without assistance other than that which is acceptable under the scheme of assessment.											
Candidate Signature						Date					

For Examiner's Use	
Examiner's Initials	
Section	Mark
Section A Part 1 Q1	
Section A Part 1 Q2	
Section A Part 2 Q1	
Section B Q1	
Section B Q2	
Section B Q3	
Section B Q4	
TOTAL	



General Certificate of Education  
Advanced Level Examination  
June 2012

# Physics (Specifications A and B)

## PHA6/B6/X

Unit 6 Investigative and Practical Skills in A2 Physics  
Route X Externally Marked Practical Assignment (EMPA)

### Section B Written Test

<p><b>For this paper you must have</b></p> <ul style="list-style-type: none"> <li>your completed Section A Part 2 question paper / answer booklet.</li> <li>a ruler</li> <li>a pencil</li> <li>a calculator.</li> </ul>	<p><b>Instructions</b></p> <ul style="list-style-type: none"> <li>Use black ink or black ball-point pen.</li> <li>Fill in the boxes at the top of this page.</li> <li>Answer <b>all</b> questions.</li> <li>You must answer the questions in the space provided. Do not write outside the box around each page or on blank pages.</li> <li>Show all your working.</li> <li>Do all rough work in this book. Cross through any work you do not want to be marked.</li> </ul>
<p><b>Time allowed</b></p> <ul style="list-style-type: none"> <li>1 hour 15 minutes</li> </ul>	<p><b>Information</b></p> <ul style="list-style-type: none"> <li>The marks for questions are shown in brackets.</li> <li>The maximum mark for this paper is 23.</li> </ul>
<p><b>Details of additional assistance (if any).</b> Did the candidate receive any help or information in the production of this work? If you answer yes, give the details below or on a separate page.</p> <p>Yes <input type="checkbox"/> No <input type="checkbox"/></p>	

<p><b>Practical Skills Verification</b> Teacher Declaration: I confirm that the candidate has met the requirement of the practical skills verification (PSV) in accordance with the instructions and criteria in section 3.8 of the specification.</p>	<p>Yes <input type="checkbox"/></p>
--	-------------------------------------

Signature of teacher ..... Date .....

As part of AQA's commitment to assist students, AQA may make your coursework available on a strictly anonymous basis to teachers, examining staff and students in paper form or electronically, through the Internet or other means, for the purpose of indicating a typical mark or for other educational purposes. In the unlikely event that your coursework is made available for the purposes stated above, you may object to this at any time and we will remove the work on reasonable notice. If you have any concerns please contact AQA.

To see how AQA complies with the Data Protection Act 1988 please see our Privacy Statement at [aqa.org.uk](http://aqa.org.uk).

**There are no questions printed on this page**

**DO NOT WRITE ON THIS PAGE  
ANSWER IN THE SPACES PROVIDED**

**Section B**

Answer **all** the questions in the spaces provided.

You will need to refer to the work you did in Section A Part 2 when answering these questions.

- 1 (a) (i)** Determine the gradient,  $G$ , of your graph of  $\frac{R}{R+R_0}$  against  $T$ .

.....  
 .....  
 .....

$$G = \dots\dots\dots$$

(2 marks)

- 1 (a) (ii)** Calculate  $GT_0$ .

.....

$$GT_0 = \dots\dots\dots$$

(2 marks)

- 1 (b)** When no resistor is connected between clip P and clip Q, the time,  $T$ , for the voltmeter reading to fall by 50% =  $T_0$ .

- 1 (b) (i)** State the value of  $R$  when  $T = T_0$ .

.....

(1 mark)

- 1 (b) (ii)** Explain how  $T_0$  could be obtained from your graph of  $\frac{R}{R+R_0}$  against  $T$ .

.....  
 .....  
 .....  
 .....

(1 mark)

**Turn over for the next question**

- 2 A student carried out the experiment on Section A Part 2, making measurements to determine the time,  $T$ , for the voltmeter reading to fall by 50% for different values of  $R$ , including smaller values than you used. The digital voltmeter used by the student had certain characteristics that may have introduced uncertainty in the measurements of  $T$ .

- 2 (a) The first characteristic is the *sample rate*; this is the rate at which readings are transferred to the display of the meter. For the type of digital voltmeter used, a typical sample rate is 2 Hz.

**Figure 6** shows how the voltmeter reading varied with time as the capacitor was discharged.

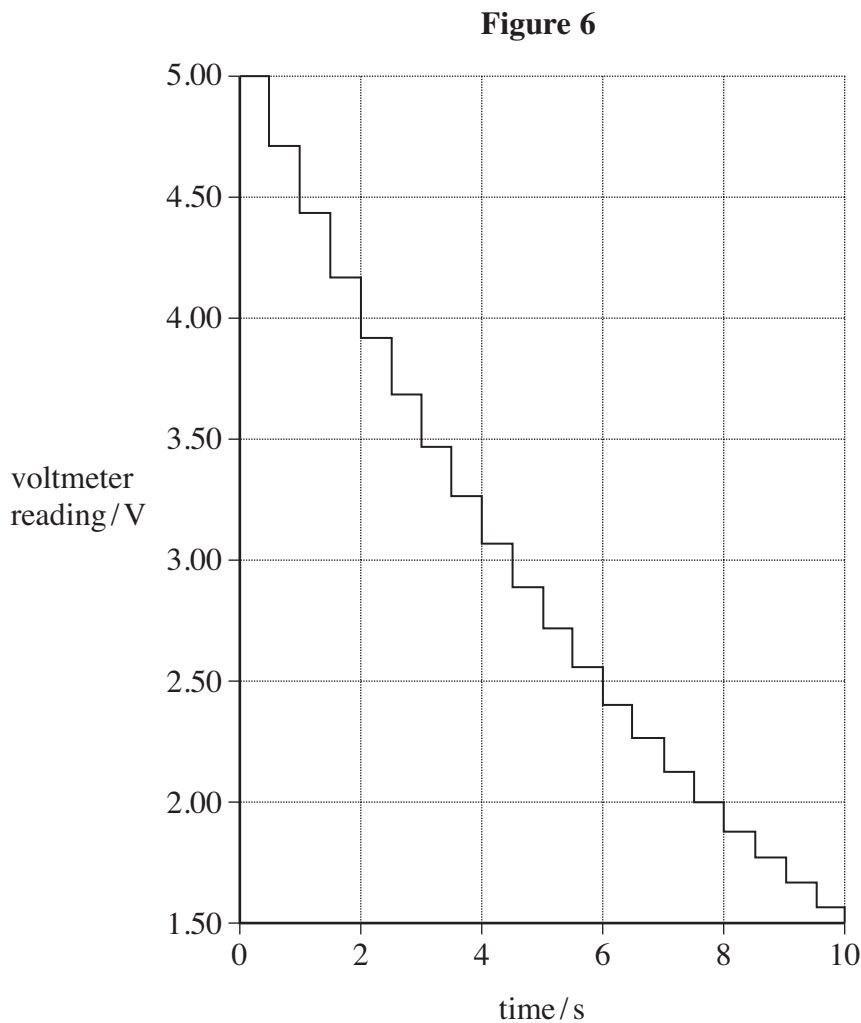

- 2 (a) (i) Explain how **Figure 6** shows that the sample rate of the voltmeter is 2 Hz.

.....

.....

(1 mark)

2 (a) (ii) With reference to **Figure 6**, outline **one** difficulty that the student would find when measuring  $T$  using the readings displayed on the voltmeter.

.....

.....

.....

.....

.....

.....

(2 marks)

2 (a) (iii) A teacher suggests that the student should wait until the voltmeter reading has fallen by 75% before stopping the watch. Explain how the value of  $T$  can be obtained using this method and explain why the uncertainty in the result would be reduced.

.....

.....

.....

.....

.....

.....

.....

.....

.....

.....

(2 marks)

**Question 2 continues on the next page**

A different student replaced the digital voltmeter with a voltage sensor connected to a data logger. The results of this experiment are shown in **Figure 7**.

**Figure 7**

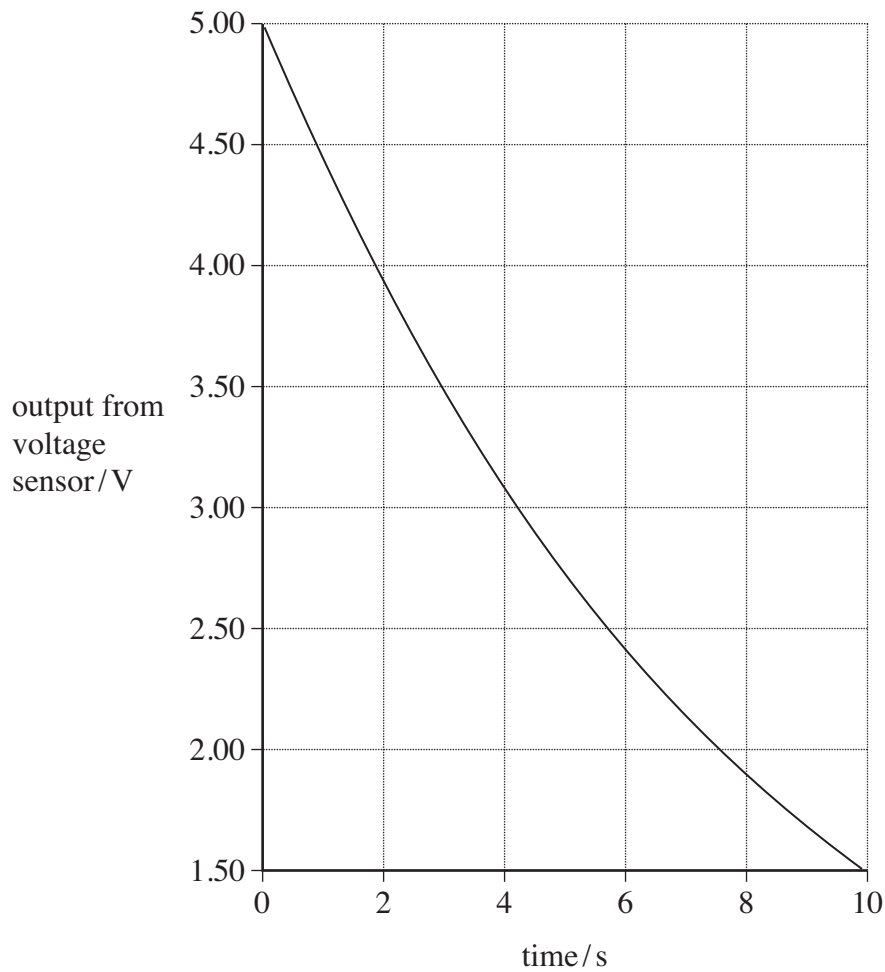

- 2 (a) (iv) Explain why the results displayed in **Figure 7** show a continuous curve whereas those represented in **Figure 6** show a stepped line.

.....

.....

(1 mark)

2 (b) The second characteristic of the meter that affects the measurements of  $T$  is the *resistance of the voltmeter*. The voltmeter provides another conducting route through which the capacitor can discharge, effectively lowering the resistance of the circuit. This causes all the readings of  $T$  to be less than they should have been.

2 (b) (i) What type of error does this cause in your measurements for  $T$ ?

.....  
(1 mark)

**Figure 8** illustrates how the resistance of the voltmeter affects the experiment.

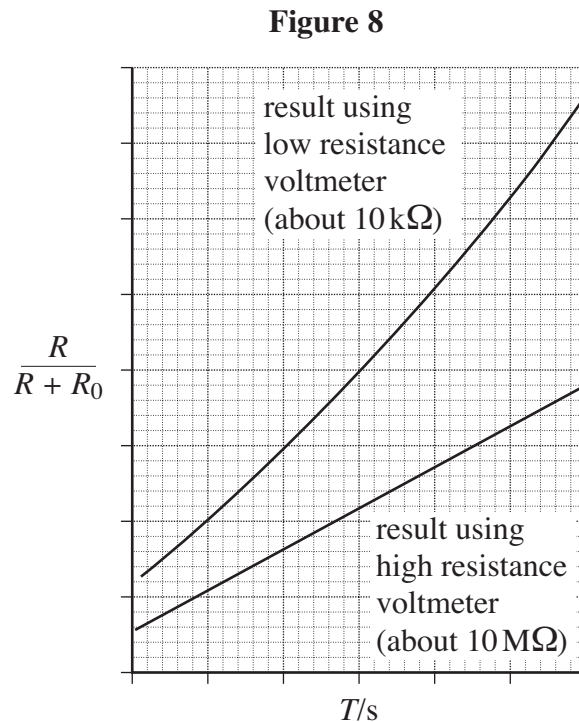

2 (b) (ii) Explain with reference to **Figure 8** whether the results of your experiment indicate that the resistance of the voltmeter you used was small enough to cause an error of this type.

.....  
.....  
.....  
.....  
(1 mark)

8

**Turn over for next question**

**Turn over ►**

- 3 In the experiment in Section A Part 1 you made measurements to calculate the radii of curvature of the surfaces of a spherical mirror. In order to check the accuracy of such an experiment, an instrument called a *spherometer* is used.

A spherometer is shown in **Figure 9**.

**Figure 9**

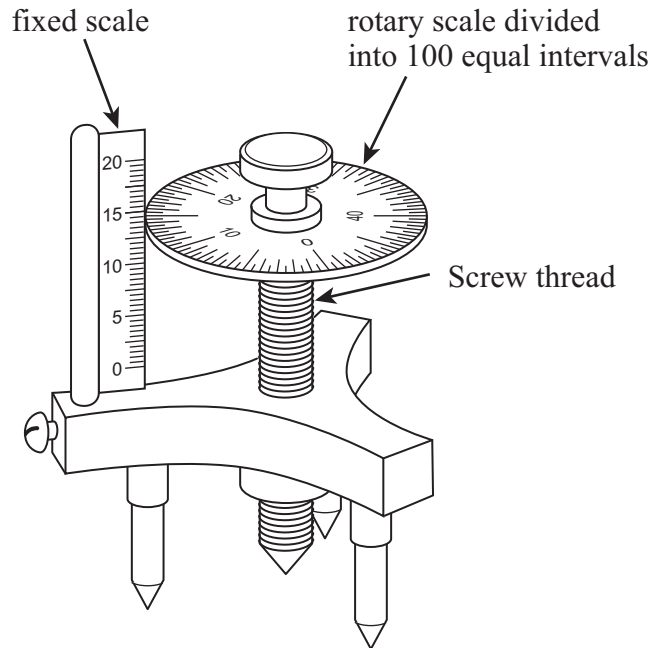

A spherometer, like a micrometer screw gauge, is a device in which a screw thread mechanism is used. One full rotation of the mechanism advances the screw 0.5 mm and this causes the rotary scale, which is divided into 100 equal intervals, to move vertically through one division of the fixed scale.

As with the micrometer screw gauge, the instrument is read by combining the readings from the fixed scale and the rotary scale.

- 3 (i) What is the precision of the spherometer?

.....  
(1 mark)



- 3 (ii) Measurements made with a spherometer show that the radius of curvature,  $R_2$ , of the convex surface of the mirror is 84.4 mm. Using the oscillating metre ruler method, a student calculates a value of  $R_2$  which is 4.5% lower than the spherometer value. Calculate the value of  $R_2$  obtained by the student.

.....

.....

.....

.....

(1 mark)

- 3 (iii) To calculate the radius of curvature,  $R_2$ , of the convex surface of the mirror, the student used the formula

$$R_2 \approx \frac{1}{3g} \left( \frac{x\pi}{T} \right)^2$$

in which  $x$  = the length of the ruler,  $g = 9.81 \text{ N kg}^{-1}$  and  $T$  is the period of the oscillations.

Assuming the uncertainties in  $x$  and  $g$  are negligible and the percentage uncertainty in  $R_2 = 4.5\%$ , calculate the percentage uncertainty in the student's result for  $T$ .

.....

.....

.....

.....

(1 mark)

- 3 (iv) Based on a single measurement of 10 oscillations, the student calculated that  $T = 2.04 \text{ s}$ . Calculate the uncertainty in the student's measurement for the time of 10 oscillations of the ruler.

.....

.....

.....

.....

(1 mark)

**Turn over for next question**

- 4 It is suggested to a student who is watching a metre ruler oscillating on the convex surface of a mirror that the amplitude of the oscillations decreases exponentially. The student is challenged to show whether or not this is true.

The student decides to record the motion of the ruler using a video camera. She attaches a pin to the end of the ruler and positions a vertical scale behind the tip of the pin, as shown in **Figure 10**.

**Figure 10**

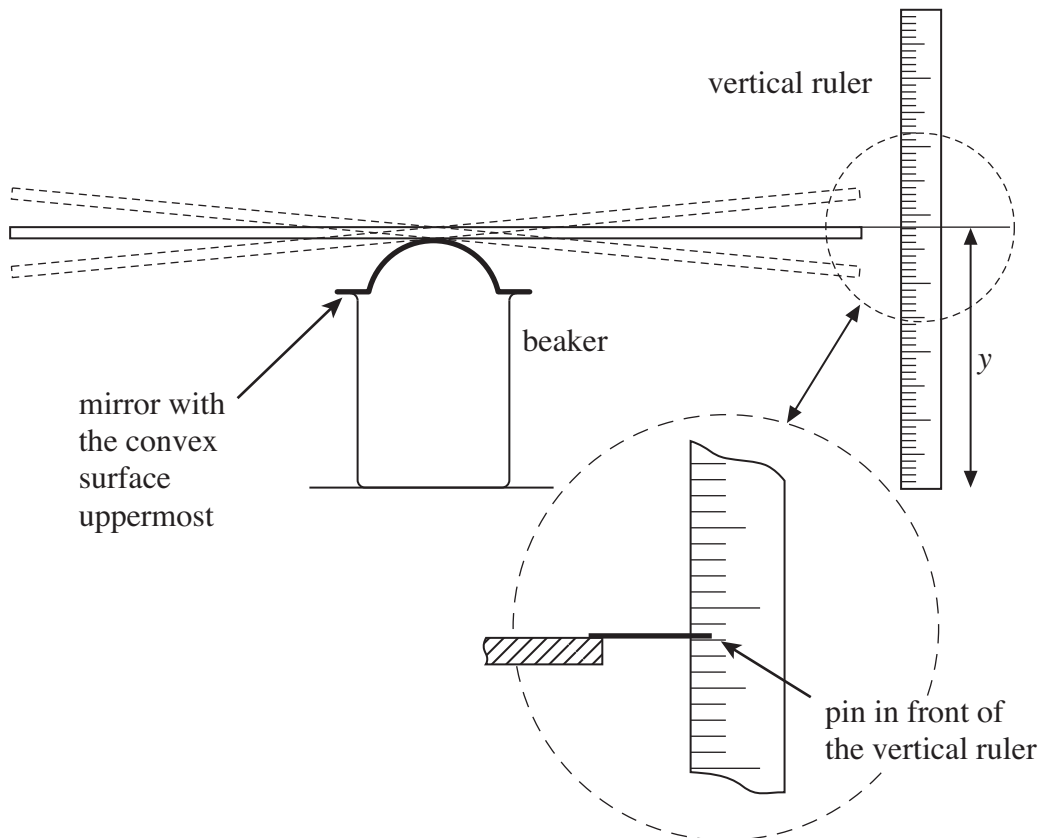

The student records the height above the bench of the tip of the pin at the top,  $y_t$ , and at the bottom,  $y_b$ , of its motion during several successive swings,  $n$ , of the ruler.

Her results are shown below.

$n$	0	1.5	3.0	4.5	6.0	7.5	9.0	10.5	12.0	13.5
$y_t/\text{cm}$	24.9		22.3		20.5		19.1		18.2	
$y_b/\text{cm}$		7.9		10.1		11.7		12.8		13.6

4 (a) Her data points are plotted on **Figure 11**.

**Figure 11**

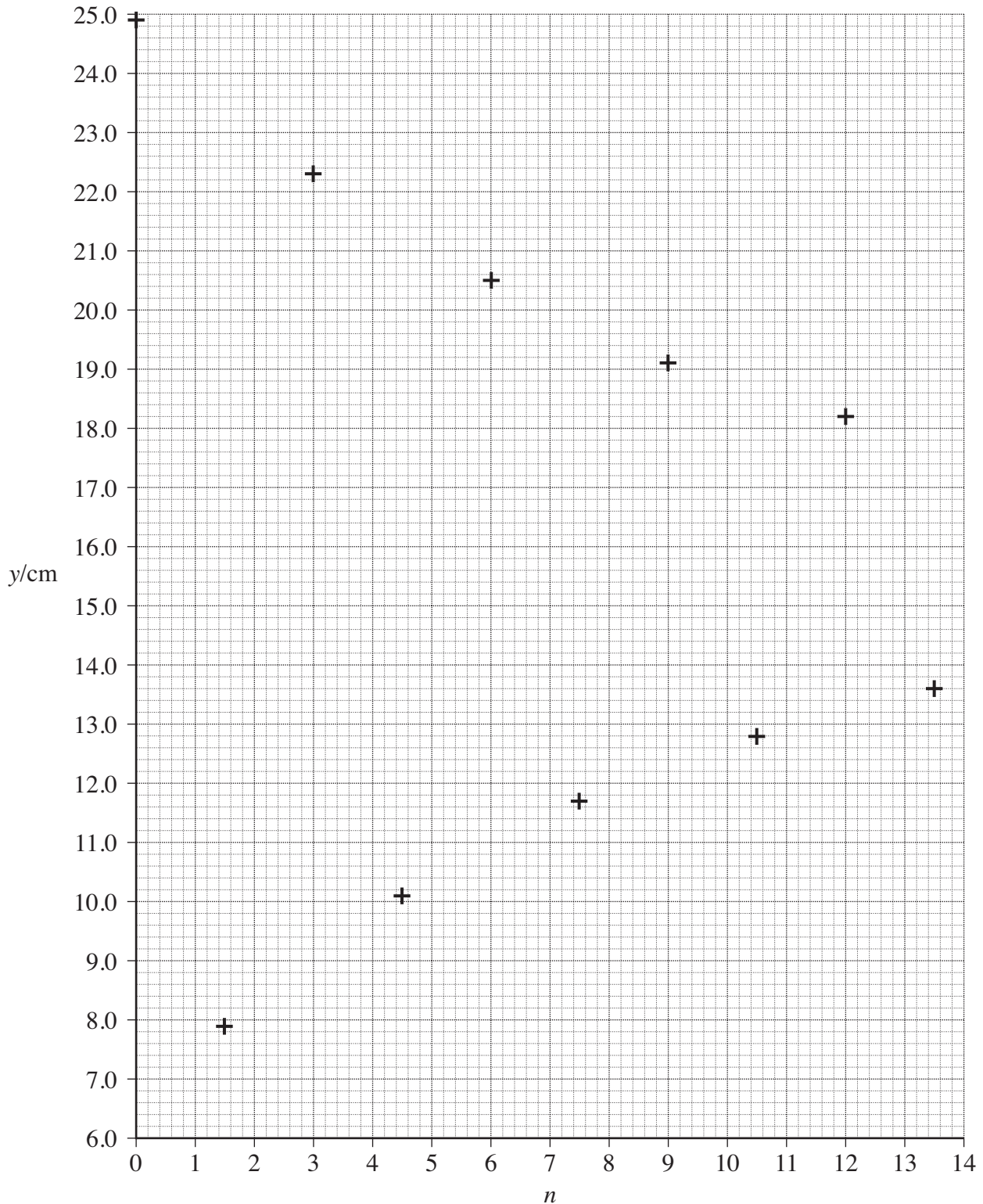

On **Figure 11** draw

- (i) a line to show how  $y_t$  varies with  $n$ ,
- (ii) a line to show how  $y_b$  varies with  $n$ ,
- (iii) a line parallel to the horizontal axis to mark the position of the tip of the pin against the vertical scale when the ruler is at the equilibrium position.

(2 marks)

Turn over ►

4 (b) Hence or otherwise, explain whether the student's data confirms the suggestion that the amplitude of the oscillations decreases exponentially.

.....

.....

.....

.....

.....

.....

.....

.....

.....

.....

.....

.....

.....

.....

.....

.....

.....

.....

.....

.....

.....

.....

(3 marks)

5
---

**END OF QUESTIONS**