

Surname		Other Names	
Centre Number		Candidate Number	
Candidate Signature			

Leave blank
-------------

General Certificate of Education  
June 2003  
Advanced Level Examination



**PHYSICS (SPECIFICATION A)  
Practical (Units 5-9)**

**PHAP**

Thursday 22 May 2003      Morning session

<p><b>In addition to this paper you will require:</b></p> <ul style="list-style-type: none"> <li>• a calculator,</li> <li>• a pencil and a ruler.</li> </ul>
--

For Examiner's Use			
Number	Mark	Nmber	Mark
1			
2			
Total (Column 1)	→		
Total (Column 2)	→		
TOTAL			
Examiner's Initials			

Time allowed: 1 hour 45 minutes

**Instructions**

- Use blue or black ink or ball-point pen.
- Fill in the boxes at the top of this page.
- Answer **both** questions in the spaces provided. All working must be shown.
- Do all rough work in this book. Cross through any work you do not want marked.

**Information**

- The maximum mark for this paper is 30.
- Mark allocations are shown in brackets.
- The paper carries 5% of the total marks for Physics Advanced.
- A *Data Sheet* is provided on pages 3 and 4. You may wish to detach this perforated sheet at the start of the examination.
- You are expected to use a calculator where appropriate.
- You are advised to spend no more than 30 minutes on Question 1.

**Data Sheet**

- A perforated Data Sheet is provided as pages 3 and 4 of this question paper.
- This sheet may be useful for answering some of the questions in the examination.
- You may wish to detach this sheet before you begin work.

Fundamental constants and values				Mechanics and Applied Physics		Fields, Waves, Quantum Phenomena	
Quantity	Symbol	Value	Units				
speed of light in vacuo	$c$	$3.00 \times 10^8$	$\text{m s}^{-1}$	$v = u + at$	$g = \frac{F}{m}$		
permeability of free space	$\mu_0$	$4\pi \times 10^{-7}$	$\text{H m}^{-1}$	$s = \left(\frac{u+v}{2}\right)t$	$g = -\frac{GM}{r^2}$		
permittivity of free space	$\epsilon_0$	$8.85 \times 10^{-12}$	$\text{F m}^{-1}$	$s = ut + \frac{at^2}{2}$	$g = -\frac{\Delta V}{\Delta x}$		
charge of electron	$e$	$1.60 \times 10^{-19}$	C	$v^2 = u^2 + 2as$	$V = -\frac{GM}{r}$		
the Planck constant	$h$	$6.63 \times 10^{-34}$	J s	$F = \frac{\Delta(mv)}{\Delta t}$	$a = -(2\pi f)^2 x$		
gravitational constant	$G$	$6.67 \times 10^{-11}$	$\text{N m}^2 \text{kg}^{-2}$	$P = Fv$	$v = \pm 2\pi f \sqrt{A^2 - x^2}$		
the Avogadro constant	$N_A$	$6.02 \times 10^{23}$	$\text{mol}^{-1}$	$\text{efficiency} = \frac{\text{power output}}{\text{power input}}$	$x = A \cos 2\pi ft$		
molar gas constant	$R$	8.31	$\text{J K}^{-1} \text{mol}^{-1}$	$\omega = \frac{v}{r} = 2\pi f$	$T = 2\pi \sqrt{\frac{m}{k}}$		
the Boltzmann constant	$k$	$1.38 \times 10^{-23}$	$\text{J K}^{-1}$	$a = \frac{v^2}{r} = r\omega^2$	$T = 2\pi \sqrt{\frac{l}{g}}$		
the Stefan constant	$\sigma$	$5.67 \times 10^{-8}$	$\text{W m}^{-2} \text{K}^{-4}$	$I = \sum mr^2$	$\lambda = \frac{ws}{D}$		
the Wien constant	$\alpha$	$2.90 \times 10^{-3}$	m K	$E_k = \frac{1}{2} I\omega^2$	$d \sin \theta = n\lambda$		
electron rest mass	$m_e$	$9.11 \times 10^{-31}$	kg	$\omega_2 = \omega_1 + at$	$\theta = \frac{\lambda}{D}$		
(equivalent to $5.5 \times 10^{-4}u$ )				$\theta = \omega_1 t + \frac{1}{2} at^2$	$1/n_2 = \frac{\sin \theta_1}{\sin \theta_2} = \frac{c_1}{c_2}$		
electron charge/mass ratio	$e/m_e$	$1.76 \times 10^{11}$	$\text{C kg}^{-1}$	$\omega_2^2 = \omega_1^2 + 2a\theta$	$1/n_2 = \frac{n_2}{n_1}$		
proton rest mass	$m_p$	$1.67 \times 10^{-27}$	kg	$\theta = \frac{1}{2} (\omega_1 + \omega_2)t$	$\sin \theta_c = \frac{1}{n}$		
(equivalent to 1.00728u)				$T = I\alpha$	$E = hf$		
proton charge/mass ratio	$e/m_p$	$9.58 \times 10^7$	$\text{C kg}^{-1}$	$\text{angular momentum} = I\omega$	$hf = \phi + E_k$		
neutron rest mass	$m_n$	$1.67 \times 10^{-27}$	kg	$W = T\theta$	$hf = E_1 - E_2$		
(equivalent to 1.00867u)				$P = T\omega$	$\lambda = \frac{h}{p} = \frac{h}{mv}$		
gravitational field strength	$g$	9.81	$\text{N kg}^{-1}$	$\text{angular impulse} = \text{change of angular momentum} = Tt$	$c = \frac{1}{\sqrt{\mu_0 \epsilon_0}}$		
acceleration due to gravity	$g$	9.81	$\text{m s}^{-2}$	$\Delta Q = \Delta U + \Delta W$			
atomic mass unit	$u$	$1.661 \times 10^{-27}$	kg	$\Delta W = p\Delta V$			
(1u is equivalent to 931.3 MeV)				$pV^\gamma = \text{constant}$			
<b>Fundamental particles</b>				<b>Electricity</b>			
Class	Name	Symbol	Rest energy /MeV	work done per cycle = area of loop	$\epsilon = \frac{E}{Q}$		
photon	photon	$\gamma$	0	input power = calorific value $\times$ fuel flow rate	$\epsilon = I(R+r)$		
lepton	neutrino	$\nu_e$	0	indicated power as (area of p - V loop) $\times$ (no. of cycles/s) $\times$ (no. of cylinders)	$\frac{1}{R_T} = \frac{1}{R_1} + \frac{1}{R_2} + \frac{1}{R_3} + \dots$		
		$\nu_\mu$	0	friction power = indicated power - brake power	$R_T = R_1 + R_2 + R_3 + \dots$		
	electron	$e^\pm$	0.510999	efficiency = $\frac{W}{Q_{in}} = \frac{Q_{in} - Q_{out}}{Q_{in}}$	$P = I^2 R$		
	muon	$\mu^\pm$	105.659	maximum possible efficiency = $\frac{T_H - T_C}{T_H}$	$E = \frac{F}{Q} = \frac{V}{d}$		
mesons	pion	$\pi^\pm$	139.576		$E = \frac{1}{4\pi\epsilon_0} \frac{Q}{r^2}$		
		$\pi^0$	134.972		$E = \frac{1}{2} QV$		
	kaon	$K^\pm$	493.821		$F = BI l$		
		$K^0$	497.762		$F = BQv$		
baryons	proton	p	938.257		$Q = Q_0 e^{-t/RC}$		
	neutron	n	939.551		$\Phi = BA$		
<b>Properties of quarks</b>							
Type	Charge	Baryon number	Strangeness				
u	$+\frac{2}{3}$	$+\frac{1}{3}$	0				
d	$-\frac{1}{3}$	$+\frac{1}{3}$	0				
s	$-\frac{1}{3}$	$+\frac{1}{3}$	-1				
<b>Geometrical equations</b>							
arc length = $r\theta$							
circumference of circle = $2\pi r$							
area of circle = $\pi r^2$							
area of cylinder = $2\pi rh$							
volume of cylinder = $\pi r^2 h$							
area of sphere = $4\pi r^2$							
volume of sphere = $\frac{4}{3}\pi r^3$							

$$\text{magnitude of induced e.m.f.} = N \frac{\Delta\Phi}{\Delta t}$$

$$I_{\text{rms}} = \frac{I_0}{\sqrt{2}}$$

$$V_{\text{rms}} = \frac{V_0}{\sqrt{2}}$$

### Mechanical and Thermal Properties

$$\text{the Young modulus} = \frac{\text{tensile stress}}{\text{tensile strain}} = \frac{F}{A} \frac{l}{e}$$

$$\text{energy stored} = \frac{1}{2} Fe$$

$$\Delta Q = mc \Delta\theta$$

$$\Delta Q = ml$$

$$pV = \frac{1}{3} Nmc^2$$

$$\frac{1}{2} mc^2 = \frac{3}{2} kT = \frac{3RT}{2N_A}$$

### Nuclear Physics and Turning Points in Physics

$$\text{force} = \frac{eV_p}{d}$$

$$\text{force} = Bev$$

$$\text{radius of curvature} = \frac{mv}{Be}$$

$$\frac{eV}{d} = mg$$

$$\text{work done} = eV$$

$$F = 6\pi\eta rv$$

$$I = k \frac{I_0}{x^2}$$

$$\frac{\Delta N}{\Delta t} = -\lambda N$$

$$\lambda = \frac{h}{\sqrt{2meV}}$$

$$N = N_0 e^{-\lambda t}$$

$$T_{\frac{1}{2}} = \frac{\ln 2}{\lambda}$$

$$R = r_0 A^{\frac{1}{3}}$$

$$E = mc^2 = \frac{m_0 c^2}{\left(1 - \frac{v^2}{c^2}\right)^{\frac{1}{2}}}$$

$$l = l_0 \left(1 - \frac{v^2}{c^2}\right)^{\frac{1}{2}}$$

$$t = \frac{t_0}{\left(1 - \frac{v^2}{c^2}\right)^{\frac{1}{2}}}$$

### Astrophysics and Medical Physics

Body	Mass/kg	Mean radius/m
Sun	$2.00 \times 10^{30}$	$7.00 \times 10^8$
Earth	$6.00 \times 10^{24}$	$6.40 \times 10^6$

$$1 \text{ astronomical unit} = 1.50 \times 10^{11} \text{ m}$$

$$1 \text{ parsec} = 206265 \text{ AU} = 3.08 \times 10^{16} \text{ m} = 3.26 \text{ ly}$$

$$1 \text{ light year} = 9.45 \times 10^{15} \text{ m}$$

$$\text{Hubble constant } (H) = 65 \text{ km s}^{-1} \text{ Mpc}^{-1}$$

$$M = \frac{\text{angle subtended by image at eye}}{\text{angle subtended by object at unaided eye}}$$

$$M = \frac{f_o}{f_c}$$

$$m - M = 5 \log \frac{d}{10}$$

$$\lambda_{\text{max}} T = \text{constant} = 0.0029 \text{ m K}$$

$$v = Hd$$

$$P = \sigma AT^4$$

$$\frac{\Delta f}{f} = \frac{v}{c}$$

$$\frac{\Delta \lambda}{\lambda} = -\frac{v}{c}$$

$$R_s \approx \frac{2GM}{c^2}$$

### Medical Physics

$$\text{power} = \frac{1}{f}$$

$$\frac{1}{u} + \frac{1}{v} = \frac{1}{f} \text{ and } m = \frac{v}{u}$$

$$\text{intensity level} = 10 \log \frac{I}{I_0}$$

$$I = I_0 e^{-\mu x}$$

$$\mu_m = \frac{\mu}{\rho}$$

### Electronics

Resistors

Preferred values for resistors (E24)  
Series: 1.0 1.1 1.2 1.3 1.5 1.6 1.8 2.0 2.2 2.4 2.7 3.0 3.3 3.6 3.9 4.3 4.7 5.1 5.6 6.2 6.8 7.5 8.2 9.1 ohms  
and multiples that are ten times greater

$$Z = \frac{V_{\text{rms}}}{I_{\text{rms}}}$$

$$\frac{1}{C_T} = \frac{1}{C_1} + \frac{1}{C_2} + \frac{1}{C_3} + \dots$$

$$C_T = C_1 + C_2 + C_3 + \dots$$

$$X_C = \frac{1}{2\pi fC}$$

### Alternating Currents

$$f = \frac{1}{T}$$

### Operational amplifier

$$G = \frac{V_{\text{out}}}{V_{\text{in}}} \quad \text{voltage gain}$$

$$G = -\frac{R_f}{R_1} \quad \text{inverting}$$

$$G = 1 + \frac{R_f}{R_1} \quad \text{non-inverting}$$

$$V_{\text{out}} = -R_f \left( \frac{V_1}{R_1} + \frac{V_2}{R_2} + \frac{V_3}{R_3} \right) \quad \text{summing}$$

Answer **both** questions.

You are advised to spend no more than 30 minutes on Question 1.

- 1 Some students are investigating the properties of a steel tuning fork. If a ceramic magnet is placed on the stem of the tuning fork as shown in the diagram, the vibrations of the prongs of the fork are unaffected and because the tuning fork has become magnetised, the prongs behave like vibrating magnetic poles.

Their teacher suggests that by positioning a search coil vertically below the vibrating tuning fork an alternating voltage will be induced in the coil. By making suitable connections to an external circuit, the students discover it is possible to use this technique to detect even the small vibrations that persist in the tuning fork after the sound produced is inaudible.

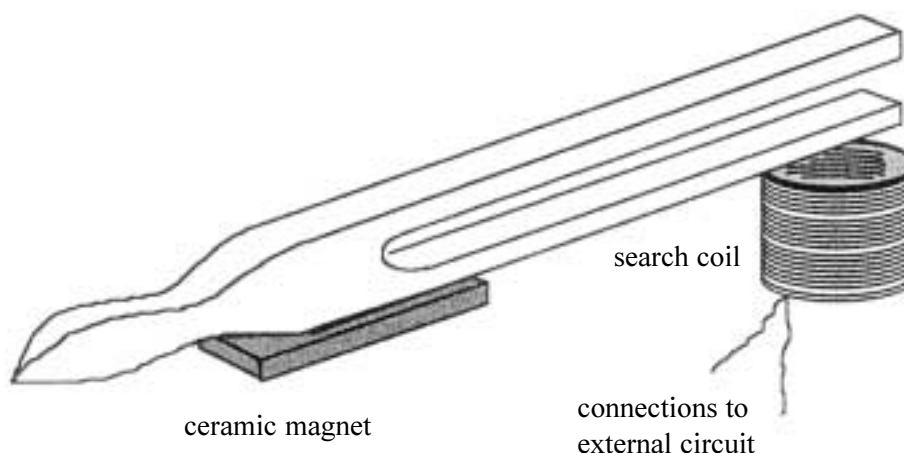

Design an experiment to investigate whether the rate of decrease in the amplitude of air-damped tuning fork vibrations depends on the natural frequency of the tuning fork.

You should assume that the normal laboratory apparatus used in schools and colleges is available to you.

You are advised to draw a suitable circuit diagram of the arrangement you intend to use as part of your answer.

You should also include the following in your answer:

- The quantities you intend to measure and how you will measure them.
- How you propose to use your measurements to compare the damping effects on different tuning forks.
- The factors you will need to control and how you will do this.
- How you could overcome any difficulties in obtaining reliable results.

*(8 marks)*

Turn over ►

- 2 In this experiment you are to investigate the discharge of a capacitor through different combinations of resistors.

**No description of the experiment is required.**

You are provided with the circuit shown below, part of which is concealed, as shown by the shaded region on the diagram.

Different series combinations of the  $2.2\text{ k}\Omega$ ,  $4.7\text{ k}\Omega$  and  $10.0\text{ k}\Omega$  resistors can be achieved in the circuit by using the spare lead to join any two of the terminals W, X, Y or Z, resulting in a resistance  $R$ . If the spare lead is not used  $R$  has a **maximum** resistance. If the spare lead is used to join W to Z,  $R$  has **zero** resistance.

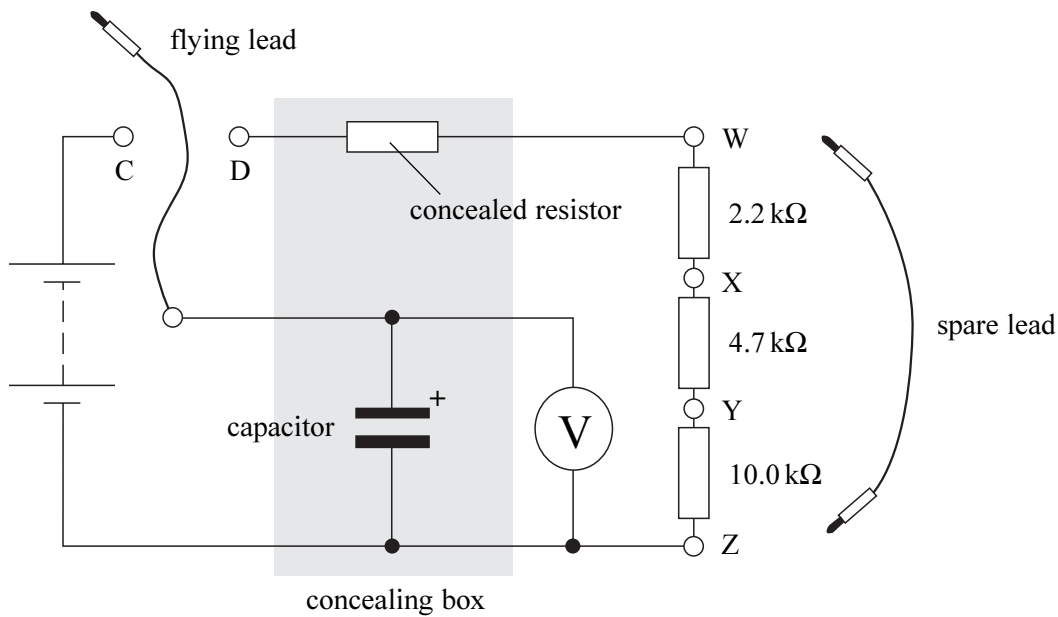

- (a) With  $R$  set to zero resistance, charge the capacitor by connecting the flying lead to terminal C. The voltmeter will show a steady reading. Discharge the capacitor by connecting the flying lead to terminal D. The voltmeter reading will start to fall exponentially. Make suitable measurements to determine  $T_0$ , the time for the voltmeter reading to decrease by 50% when  $R = 0$ .

.....

.....

.....

.....

.....

.....

Turn over ►

- (b) Repeating the procedure for charging and discharging the capacitor, make suitable measurements to obtain values of  $T$ , the time for the voltmeter reading to decrease by 50%, corresponding to all possible **non-zero** values of  $R$  up to and including the maximum external resistance that can be included in the circuit.

Tabulate all your observations below.

.....

.....

.....

.....

.....

.....

.....

.....

.....

.....

.....

.....

.....

.....

.....

.....

.....

.....

(7 marks)

- (c) On the grid opposite, plot a graph of your results with  $T$  on the vertical axis and  $R$  on the horizontal axis. Include the data set where  $T = T_0, R = 0$ .

(6 marks)

- (d) (i) Measure and record the gradient,  $G$ , of your graph.

$G =$  .....

- (ii) Evaluate  $\frac{T_0}{G}$ .

$\frac{T_0}{G} =$  .....

(3 marks)

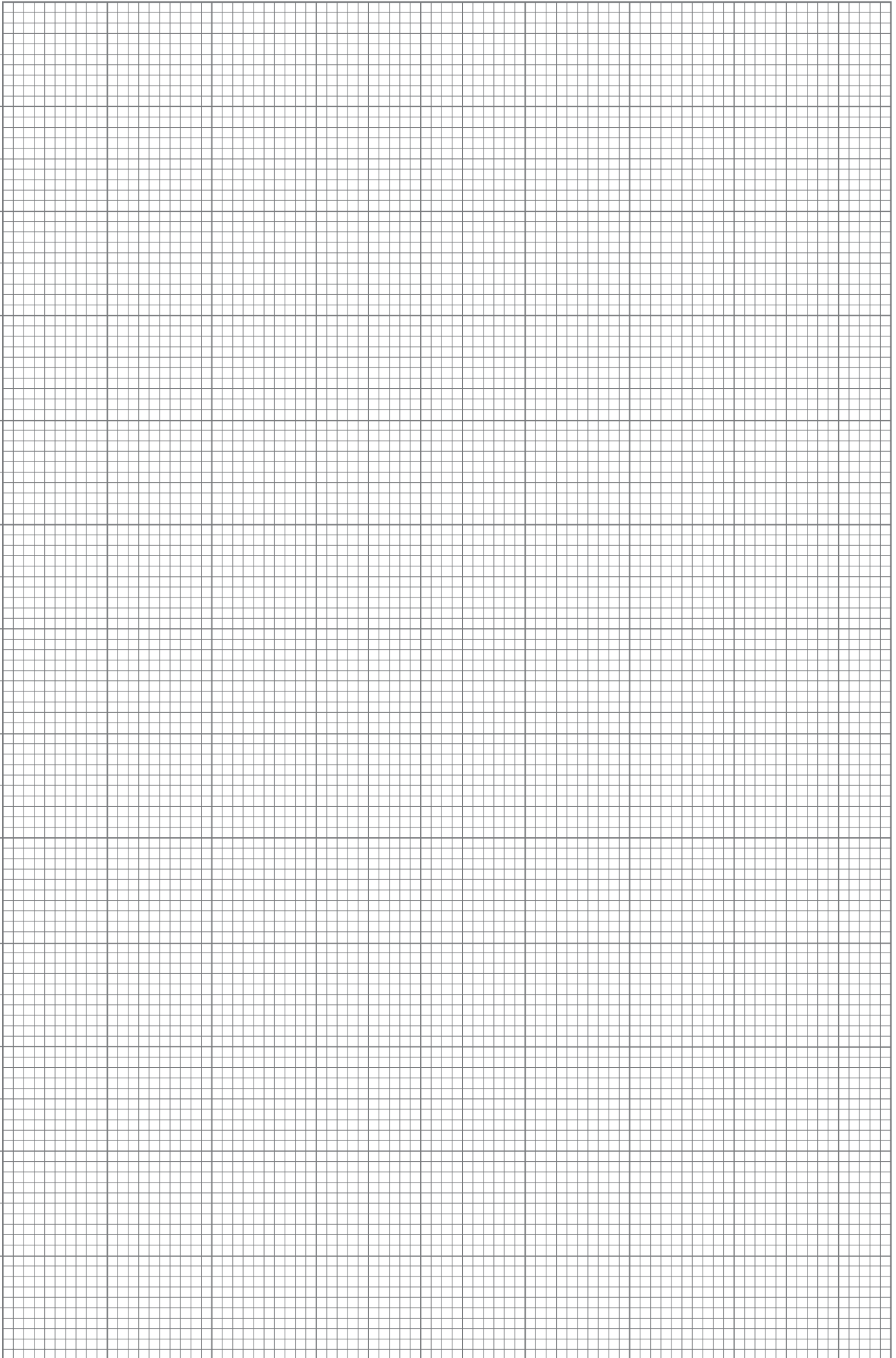



- (e) (i) To enable the digital display on a certain voltmeter to be recognised, the read-out only changes twice per second. This presents a problem in knowing exactly when to start and stop the watch (to determine  $T$ ).  
Explain which readings of  $T$  that you made are likely to be affected most by this problem.

.....

.....

.....

.....

.....

.....

- (ii) The problem identified in part (e)(i) could be eliminated if an analogue voltmeter (in which a needle moves across a fixed scale) was used: this type of meter makes judging a particular value easier. However most analogue voltmeters usually have a low resistance, often as small as  $10\text{ k}\Omega$ .  
Explain, with the aid of a sketch, the change that would be produced in the graph if such a voltmeter were used for the experiment.

.....

.....

.....

.....

.....

.....

.....

(6 marks)

**END OF QUESTIONS**

<b>Instructions to Supervisors for the Practical Examination (Units 5-9)</b>
--

**CONFIDENTIAL**

**OPEN ON RECEIPT**

The examination will be held on Thursday 22 May 2003 Morning Session

- These *Instructions* are provided to enable centres to make appropriate arrangements for the examination. Copies of the *Instructions* are to be kept at the centre under lock and key when not in use; they are not to be removed from the centre. The question paper packets must not be opened prior to the examination.
- These instructions explain how to set up the equipment for Question 2.
- Question 2 is printed on pages 4 to 5 of this instruction booklet.
- Centres are at liberty to make any reasonable minor modifications to the apparatus which may be required for the successful working of the experiment but a note of all such modifications must be forwarded to the Examiner with the scripts. However, any such modifications must permit the experiment to be carried out in the specified manner.

Candidates are to investigate the discharge of a capacitor through different combinations of resistors.

**Apparatus required for each candidate:**

- stopwatch capable of reading to 0.1 s or better

**for circuit (diagram below)**

- digital voltmeter (or equivalent multimeter) capable of 0.1 V resolution or better
- d.c. supply with emf in range 50% to 90% of full-scale reading of available voltmeters, e.g. for 2000 mV digital meter, 1.5 V 'D-type' cell in good condition, in a suitable holder
- 2.2 k $\Omega$ , 4.7 k $\Omega$ , 10 k $\Omega$ , 12 k $\Omega$  resistor, 0.5 W or 0.6 W metal or carbon film
- one 2200  $\mu$ F electrolytic capacitor
- 4 mm round sockets labelled 'C' and 'D' (see diagram) and lead terminated at one end with 4 mm plug, labelled 'flying lead'
- 4 mm round sockets labelled 'W', 'X', 'Y' and 'Z' and one connecting lead, ends terminated with 4 mm plugs, labelled 'spare lead'; as an alternative, centres may use solder pins for 'W', 'X', 'Y' and 'Z' and provide **one** 'spare lead' with ends terminated at crocodile clips
- stripboard if soldered circuit is used
- means of concealment for capacitor and 12 k $\Omega$  resistor (see diagram)

The supervisor should assemble the circuit shown in the diagram. The portion that is shaded should be concealed from the candidates, e.g. in a suitable box or using opaque tape.

**Ensure that only one 'spare lead' is available per candidate.**

The choice of power supply is at the discretion of the centre and rests on the type of voltmeter available. Voltmeters should be digital and offer a resistance of at least 50 k $\Omega$ .

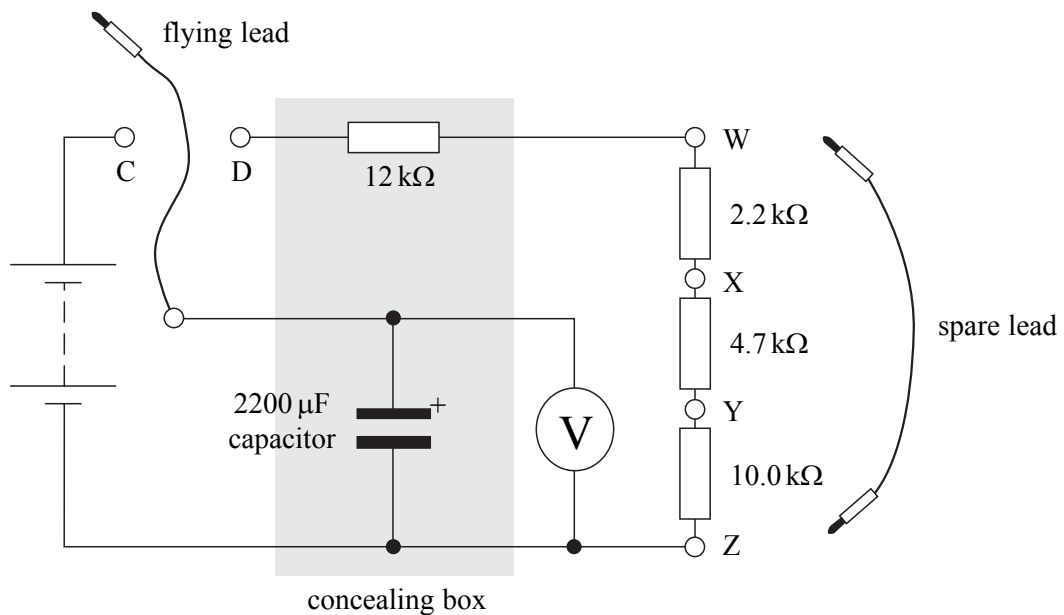

If multimeters are to be used the attention of candidates can be drawn to the appropriate setting before the commencement of the experiment.

Testing the circuit:

Connect the spare lead between terminals 'W' and 'Z' then charge the capacitor by connecting the flying lead to the terminal marked 'C'. Discharge the capacitor through the 12 k $\Omega$  resistor and measure the time for the voltmeter reading to fall by 50%. The theoretical time obtained should be 18.3 s but given the tolerances of the components involved, a time in the range of 15 to 21 s is acceptable. If the procedure is repeated with the spare lead removed a theoretical time of 44.1 s for the voltmeter reading to fall by 50% is expected (a time in the range 39 to 49 s is acceptable).

**The examiners require no information for this question.**