

Surname		Other Names	
Centre Number		Candidate Number	
Candidate Signature			

Leave blank

General Certificate of Education
 June 2003
 Advanced Level Examination



PHYSICS (SPECIFICATION A)
Unit 9 Nuclear Instability: Electronics Option

PHA9/W

Friday 20 June 2003 Afternoon Session

In addition to this paper you will require:

- a calculator;
- a pencil and a ruler.

For Examiner's Use			
Number	Mark	Number	Mark
1			
2			
3			
4			
Total (Column 1)	→		
Total (Column 2)	→		
TOTAL			
Examiner's Initials			

Time allowed: 1 hour 15 minutes

Instructions

- Use blue or black ink or ball-point pen.
- Fill in the boxes at the top of this page.
- Answer **all** questions in the spaces provided. All working must be shown.
- Do all rough work in this book. Cross through any work you do not want marked.

Information

- The maximum mark for this paper is 40.
- Mark allocations are shown in brackets.
- The paper carries 10% of the total marks for Physics Advanced.
- A *Data Sheet* is provided on pages 3 and 4. You may wish to detach this perforated sheet at the start of the examination.
- You are expected to use a calculator where appropriate.
- In questions requiring description and explanation you will be assessed on your ability to use an appropriate form and style of writing, to organise relevant information clearly and coherently, and to use specialist vocabulary where appropriate. The degree of legibility of your handwriting and the level of accuracy of your spelling, punctuation and grammar will also be taken into account.

Data Sheet

- A perforated *Data Sheet* is provided as pages 3 and 4 of this question paper.
- This sheet may be useful for answering some of the questions in the examination.
- You may wish to detach this sheet before you begin work.

Fundamental constants and values				Mechanics and Applied Physics		Fields, Waves, Quantum Phenomena		
Quantity	Symbol	Value	Units					
speed of light in vacuo	c	3.00×10^8	m s^{-1}	$v = u + at$	$g = \frac{F}{m}$			
permeability of free space	μ_0	$4\pi \times 10^{-7}$	H m^{-1}	$s = \left(\frac{u+v}{2}\right)t$	$g = -\frac{GM}{r^2}$			
permittivity of free space	ϵ_0	8.85×10^{-12}	F m^{-1}	$s = ut + \frac{at^2}{2}$	$g = -\frac{\Delta V}{\Delta x}$			
charge of electron	e	1.60×10^{-19}	C	$v^2 = u^2 + 2as$	$V = -\frac{GM}{r}$			
the Planck constant	h	6.63×10^{-34}	J s	$F = \frac{\Delta(mv)}{\Delta t}$	$a = -(2\pi f)^2 x$			
gravitational constant	G	6.67×10^{-11}	$\text{N m}^2 \text{kg}^{-2}$	$P = Fv$	$v = \pm 2\pi f \sqrt{A^2 - x^2}$			
the Avogadro constant	N_A	6.02×10^{23}	mol^{-1}	$\text{efficiency} = \frac{\text{power output}}{\text{power input}}$	$x = A \cos 2\pi ft$			
molar gas constant	R	8.31	$\text{J K}^{-1} \text{mol}^{-1}$	$\omega = \frac{v}{r} = 2\pi f$	$T = 2\pi \sqrt{\frac{m}{k}}$			
the Boltzmann constant	k	1.38×10^{-23}	J K^{-1}	$a = \frac{v^2}{r} = r\omega^2$	$T = 2\pi \sqrt{\frac{l}{g}}$			
the Stefan constant	σ	5.67×10^{-8}	$\text{W m}^{-2} \text{K}^{-4}$	$I = \sum mr^2$	$\lambda = \frac{\omega s}{D}$			
the Wien constant	α	2.90×10^{-3}	m K	$E_k = \frac{1}{2} I \omega^2$	$d \sin \theta = n\lambda$			
electron rest mass	m_e	9.11×10^{-31}	kg	$\omega_2 = \omega_1 + at$	$\theta \approx \frac{\lambda}{D}$			
(equivalent to $5.5 \times 10^{-4}u$)				$\theta = \omega_1 t + \frac{1}{2} at^2$	${}^1n_2 = \frac{\sin \theta_1}{\sin \theta_2} = \frac{c_1}{c_2}$			
electron charge/mass ratio	em_e	1.76×10^{11}	C kg^{-1}	$\omega_2^2 = \omega_1^2 + 2\alpha\theta$	${}^1n_2 = \frac{n_2}{n_1}$			
proton rest mass	m_p	1.67×10^{-27}	kg	$\theta = \frac{1}{2} (\omega_1 + \omega_2)t$	$\sin \theta_c = \frac{1}{n}$			
(equivalent to 1.00728u)				$T = I\alpha$	$E = hf$			
proton charge/mass ratio	em_p	9.58×10^7	C kg^{-1}	$\text{angular momentum} = I\omega$	$hf = \phi + E_k$			
neutron rest mass	m_n	1.67×10^{-27}	kg	$W = T\theta$	$hf = E_1 - E_2$			
(equivalent to 1.00867u)				$P = T\omega$	$\lambda = \frac{h}{p} = \frac{h}{mv}$			
gravitational field strength	g	9.81	N kg^{-1}	$\text{angular impulse} = \text{change of angular momentum} = Tt$	$c = \frac{1}{\sqrt{\mu_0 \epsilon_0}}$			
acceleration due to gravity	g	9.81	m s^{-2}	$\Delta Q = \Delta U + \Delta W$				
atomic mass unit	u	1.661×10^{-27}	kg	$\Delta W = p\Delta V$				
(1u is equivalent to 931.3 MeV)				$pV^\gamma = \text{constant}$				
Fundamental particles				$\text{work done per cycle} = \text{area of loop}$	Electricity			
<i>Class</i>	<i>Name</i>	<i>Symbol</i>	<i>Rest energy</i>	$\text{input power} = \text{calorific value} \times \text{fuel flow rate}$	$\epsilon = \frac{E}{Q}$			
			/MeV	$\text{indicated power as (area of } p-V \text{ loop)} \times (\text{no. of cycles/s}) \times (\text{no. of cylinders})$	$\epsilon = I(R+r)$			
photon	photon	γ	0	$\text{friction power} = \text{indicated power} - \text{brake power}$	$\frac{1}{R_T} = \frac{1}{R_1} + \frac{1}{R_2} + \frac{1}{R_3} + \dots$			
lepton	neutrino	ν_e	0	$\text{efficiency} = \frac{W}{Q_{in}} = \frac{Q_{in} - Q_{out}}{Q_{in}}$	$R_T = R_1 + R_2 + R_3 + \dots$			
		ν_μ	0	$\text{maximum possible efficiency} = \frac{T_H - T_C}{T_H}$	$P = I^2 R$			
mesons	electron	e^\pm	0.510999		$E = \frac{F}{Q} = \frac{V}{d}$			
		muon	μ^\pm	105.659		$E = \frac{1}{4\pi\epsilon_0} \frac{Q}{r^2}$		
		pion	π^\pm	139.576		$E = \frac{1}{2} QV$		
mesons	kaon	K^\pm	493.821		$F = BIl$			
			K^0	497.762		$F = BQv$		
baryons	proton	p	938.257		$Q = Q_0 e^{-t/RC}$			
		neutron	n	939.551		$\Phi = BA$		
Properties of quarks								
<i>Type</i>	<i>Charge</i>	<i>Baryon number</i>	<i>Strangeness</i>					
u	$+\frac{2}{3}$	$+\frac{1}{3}$	0					
d	$-\frac{1}{3}$	$+\frac{1}{3}$	0					
s	$-\frac{1}{3}$	$+\frac{1}{3}$	-1					
Geometrical equations								
arc length = $r\theta$								
circumference of circle = $2\pi r$								
area of circle = πr^2								
area of cylinder = $2\pi rh$								
volume of cylinder = $\pi r^2 h$								
area of sphere = $4\pi r^2$								
volume of sphere = $\frac{4}{3}\pi r^3$								

$$\text{magnitude of induced e.m.f.} = N \frac{\Delta\Phi}{\Delta t}$$

$$I_{\text{rms}} = \frac{I_0}{\sqrt{2}}$$

$$V_{\text{rms}} = \frac{V_0}{\sqrt{2}}$$

Mechanical and Thermal Properties

$$\text{the Young modulus} = \frac{\text{tensile stress}}{\text{tensile strain}} = \frac{F}{A} \frac{l}{e}$$

$$\text{energy stored} = \frac{1}{2} Fe$$

$$\Delta Q = mc \Delta\theta$$

$$\Delta Q = ml$$

$$pV = \frac{1}{3} Nmc^2$$

$$\frac{1}{2} mc^2 = \frac{3}{2} kT = \frac{3RT}{2N_A}$$

Nuclear Physics and Turning Points in Physics

$$\text{force} = \frac{eV_p}{d}$$

$$\text{force} = Bev$$

$$\text{radius of curvature} = \frac{mv}{Be}$$

$$\frac{eV}{d} = mg$$

$$\text{work done} = eV$$

$$F = 6\pi\eta rv$$

$$I = k \frac{I_0}{x^2}$$

$$\frac{\Delta N}{\Delta t} = -\lambda N$$

$$\lambda = \frac{h}{\sqrt{2}meV}$$

$$N = N_0 e^{-\lambda t}$$

$$T_{\frac{1}{2}} = \frac{\ln 2}{\lambda}$$

$$R = r_0 A^{\frac{1}{3}}$$

$$E = mc^2 = \frac{m_0 c^2}{\left(1 - \frac{v^2}{c^2}\right)^{\frac{1}{2}}}$$

$$l = l_0 \left(1 - \frac{v^2}{c^2}\right)^{\frac{1}{2}}$$

$$t = \frac{t_0}{\left(1 - \frac{v^2}{c^2}\right)^{\frac{1}{2}}}$$

Astrophysics and Medical Physics

Body	Mass/kg	Mean radius/m
Sun	2.00×10^{30}	7.00×10^8
Earth	6.00×10^{24}	6.40×10^6

$$1 \text{ astronomical unit} = 1.50 \times 10^{11} \text{ m}$$

$$1 \text{ parsec} = 206265 \text{ AU} = 3.08 \times 10^{16} \text{ m} = 3.26 \text{ ly}$$

$$1 \text{ light year} = 9.45 \times 10^{15} \text{ m}$$

$$\text{Hubble constant } (H) = 65 \text{ km s}^{-1} \text{ Mpc}^{-1}$$

$$M = \frac{\text{angle subtended by image at eye}}{\text{angle subtended by object at unaided eye}}$$

$$M = \frac{f_o}{f_c}$$

$$m - M = 5 \log \frac{d}{10}$$

$$\lambda_{\text{max}} T = \text{constant} = 0.0029 \text{ m K}$$

$$v = Hd$$

$$P = \sigma AT^4$$

$$\frac{\Delta f}{f} = \frac{v}{c}$$

$$\frac{\Delta \lambda}{\lambda} = -\frac{v}{c}$$

$$R_s = \frac{2GM}{c^2}$$

Medical Physics

$$\text{power} = \frac{1}{f}$$

$$\frac{1}{u} + \frac{1}{v} = \frac{1}{f} \text{ and } m = \frac{v}{u}$$

$$\text{intensity level} = 10 \log \frac{I}{I_0}$$

$$I = I_0 e^{-\mu x}$$

$$\mu_m = \frac{\mu}{\rho}$$

Electronics

Resistors

Preferred values for resistors (E24)
Series: 1.0 1.1 1.2 1.3 1.5 1.6 1.8 2.0 2.2
2.4 2.7 3.0 3.3 3.6 3.9 4.3 4.7 5.1 5.6 6.2
6.8 7.5 8.2 9.1 ohms
and multiples that are ten times greater

$$Z = \frac{V_{\text{rms}}}{I_{\text{rms}}}$$

$$\frac{1}{C_T} = \frac{1}{C_1} + \frac{1}{C_2} + \frac{1}{C_3} + \dots$$

$$C_T = C_1 + C_2 + C_3 + \dots$$

$$X_C = \frac{1}{2\pi f C}$$

Alternating Currents

$$f = \frac{1}{T}$$

Operational amplifier

$$G = \frac{V_{\text{out}}}{V_{\text{in}}} \quad \text{voltage gain}$$

$$G = -\frac{R_f}{R_1} \quad \text{inverting}$$

$$G = 1 + \frac{R_f}{R_1} \quad \text{non-inverting}$$

$$V_{\text{out}} = -R_f \left(\frac{V_1}{R_1} + \frac{V_2}{R_2} + \frac{V_3}{R_3} \right) \quad \text{summing}$$

SECTION A: NUCLEAR INSTABILITY

Answer **all** parts of this question.

1 **Figure 1** shows a grid of neutron number against proton number. A nucleus ${}^A_Z\text{X}$ is marked.

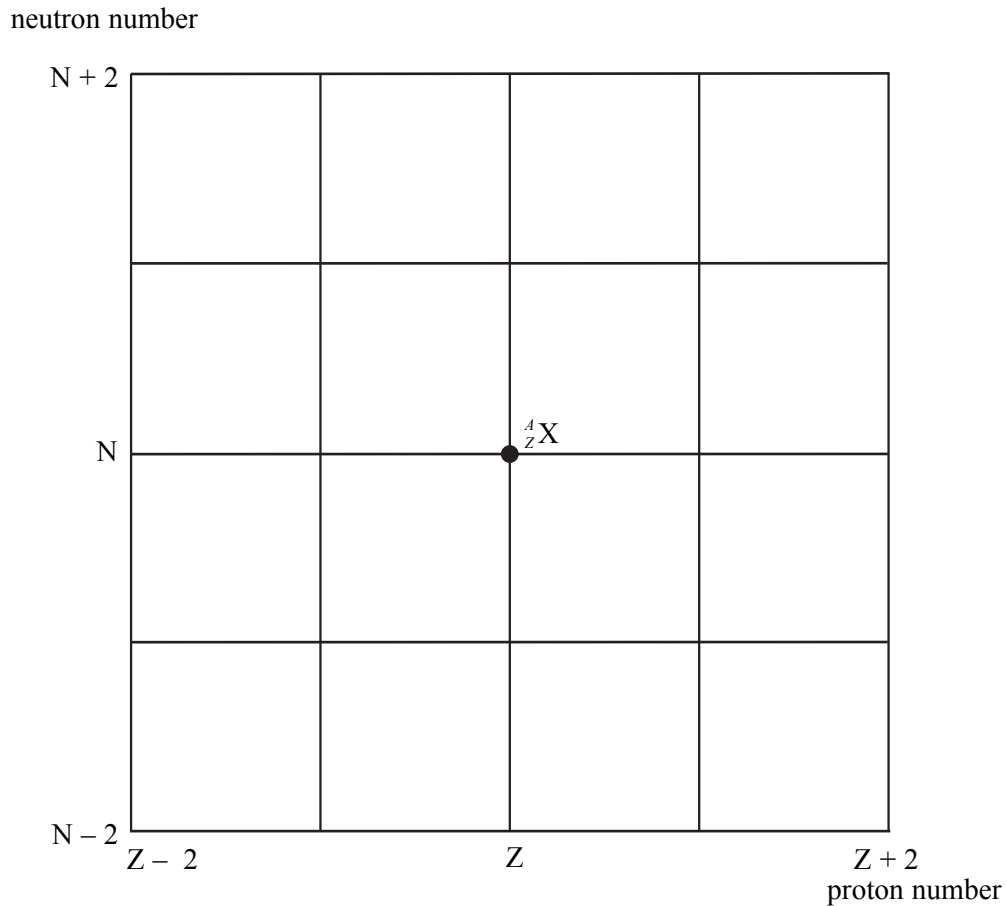

- (a) Draw arrows on **Figure 1**, each starting on ${}^A_Z\text{X}$ and ending on a daughter nucleus after the following transitions:
- (i) β^- emission (label this arrow A)
neutron emission (label this arrow B)
electron capture (label this arrow C).
 - (ii) Give the equation for electron capture by the nucleus ${}^A_Z\text{X}$.

.....
(4 marks)

Turn over ►

- (b) When ${}_{12}^{27}\text{Mg}$ decays to ${}_{13}^{27}\text{Al}$ by β^- decay, the daughter nucleus is produced in one of two possible excited states. These two states are shown in **Figure 2** together with their corresponding energies.

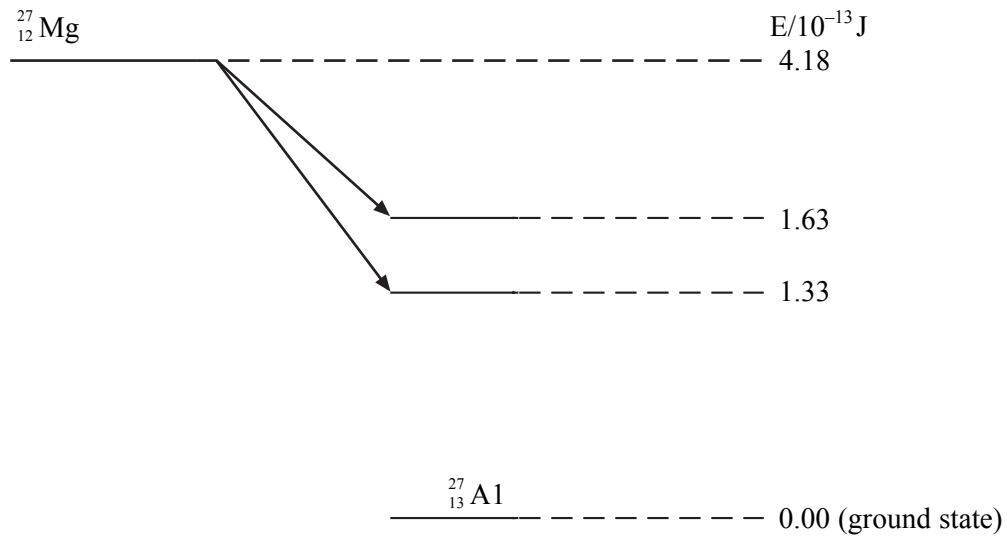

Figure 2

- (i) Calculate the maximum possible kinetic energy, in J, which an emitted β^- particle can have.

.....

- (ii) The excited aluminium nuclei emit γ photons. Calculate each of the three possible γ photon energies in J.

.....

- (iii) Calculate the frequency of the most energetic γ photon emitted.

.....

(3 marks)

- (c) (i) State and explain **two** precautions that should be taken when working with a sample of ${}_{12}^{27}\text{Mg}$ in a school laboratory.

You may be awarded marks for the quality of written communication in your answer.

.....

.....

.....

.....

.....

.....

.....

.....

- (ii) Discuss which of the two types of radiation, β^- or γ , emitted from a sample of ${}_{12}^{27}\text{Mg}$ would be the more hazardous.

.....

.....

.....

(3 marks)

10

TURN OVER FOR THE NEXT QUESTION

Turn over ▶

SECTION B: ELECTRONICSAnswer **all** questions.

- 2 (a) A capacitor is connected in series with an ac milliammeter and a 10 Vrms variable frequency sinusoidal alternating supply as shown in the circuit in **Figure 1**.

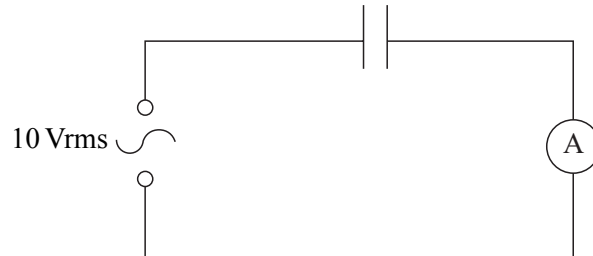
**Figure 1**

The frequency of the supply is increased in steps from a low value and the rms current is measured at these frequencies. The values obtained are shown in the table.

frequency/Hz	rms current/mA
200	2.26
500	5.70
800	8.80
1100	12.28
1400	15.80
1600	17.82

- (i) Using suitable scales, plot a graph of current against frequency on the grid opposite.
- (ii) Using your graph, calculate the capacitance of the capacitor.

.....

.....

.....

.....

.....

.....

*(5 marks)***QUESTION 2 CONTINUES ON PAGE 10**

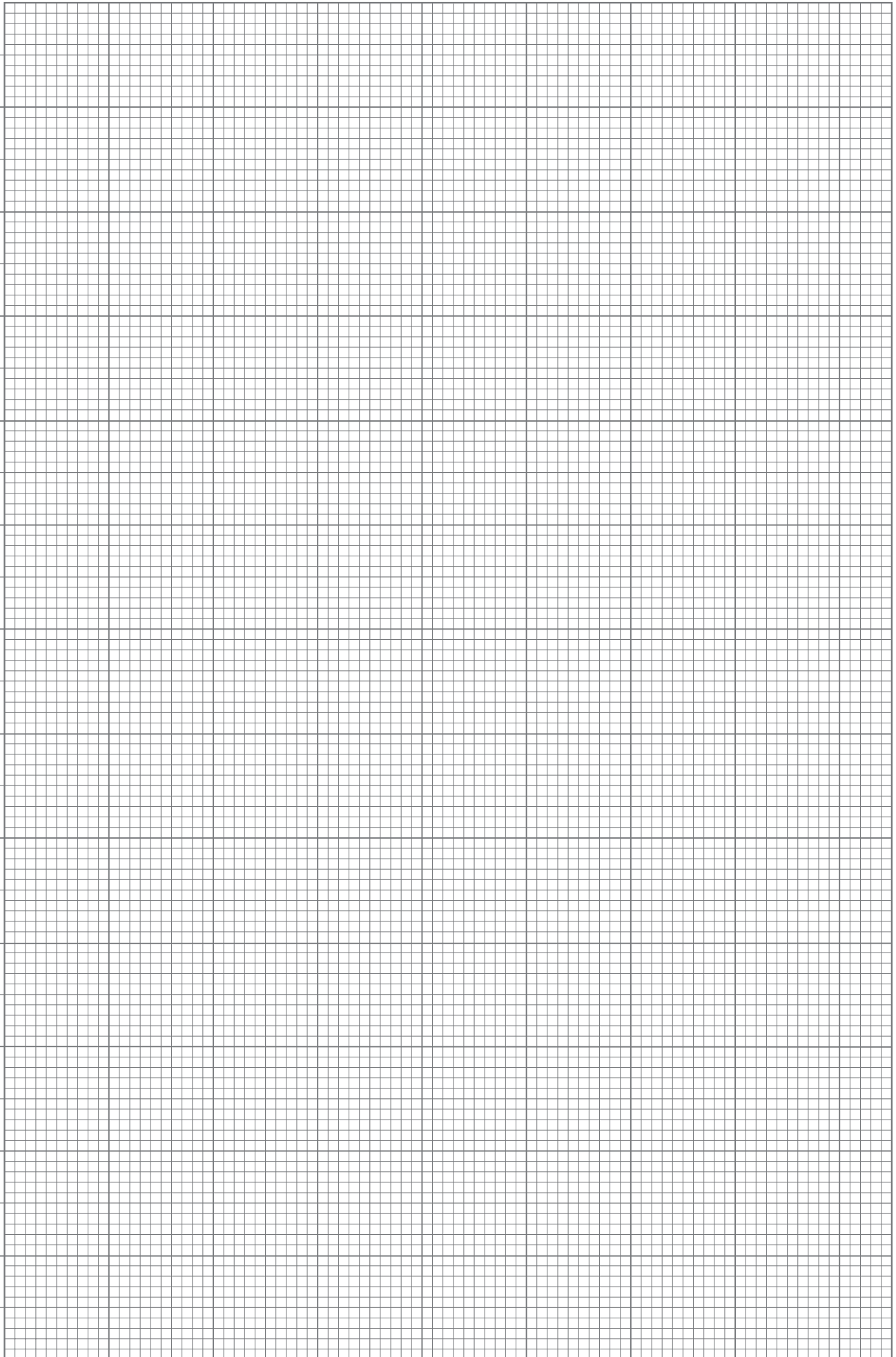

Turn over ▶

- (b) The same capacitor is now included in a low-pass filter circuit, as shown in **Figure 2**.

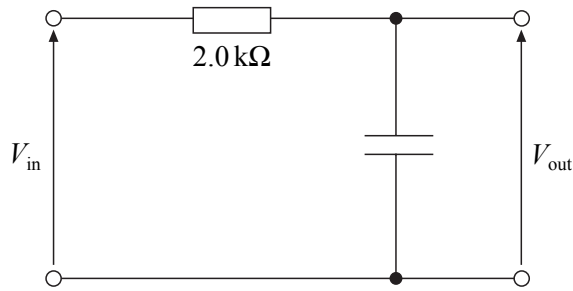

Figure 2

- (i) Explain why $\frac{V_{out}}{V_{in}}$ has a low value at high frequencies.

.....

.....

.....

.....

- (ii) Calculate the frequency at which the reactance of the capacitor equals the resistance of the resistor.

.....

.....

.....

.....

- (iii) Deduce the approximate value of $\frac{V_{out}}{V_{in}}$ at frequencies considerably less than the value calculated in part (b)(ii).

.....

.....

.....

.....

(5 marks)

- 3 The circuit shown is that of a simple burglar alarm where the switch S is a **normally closed** window switch. Both relay switches are initially open. The transistor, TR, is used as a switch and is either switched off or fully conducting.

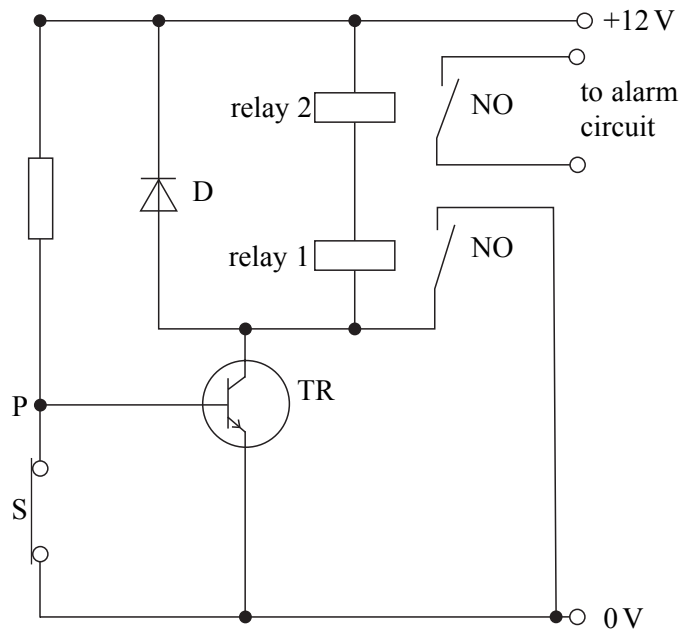

- (a) (i) Give the approximate voltage at P when S is closed.

.....

.....

- (ii) Hence explain why the alarm is off.

.....

.....

.....

.....

(3 marks)

- (b) Switch S is now opened. Explain why the alarm is triggered.

You may be awarded marks for the quality of written communication in your answer.

.....
.....
.....
.....
.....
.....

(2 marks)

- (c) If S is closed again, explain why the alarm continues to ring.

.....
.....
.....
.....

(2 marks)

- (d) State the function of the diode D in the circuit.

.....

(1 mark)



TURN OVER FOR THE NEXT QUESTION

Turn over ▶

- 4 In the circuit shown, an ideal operational amplifier is used as a voltage comparator.

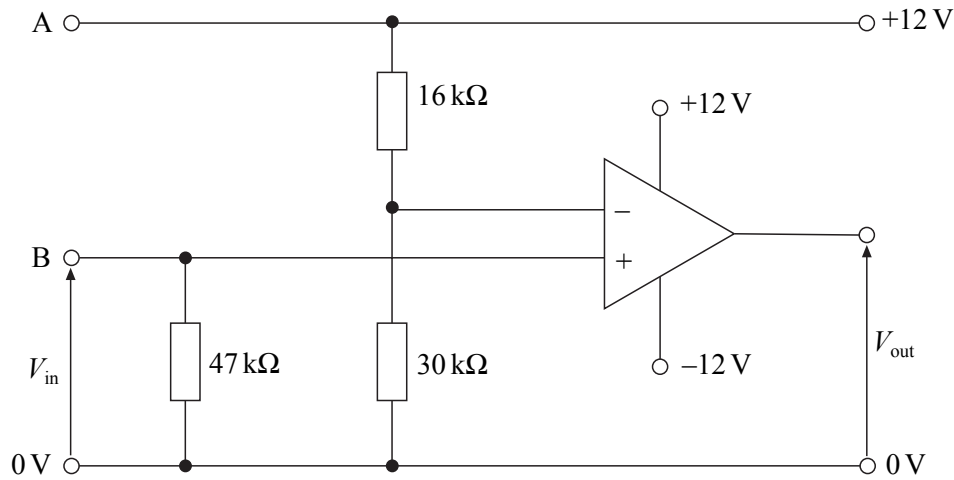

- (a) The voltage V_{in} is steadily increased from 0 V. Calculate V_{in} when the sign of V_{out} changes from negative to positive.

.....

.....

.....

(2 marks)

- (b) (i) The op-amp is required to operate an LED. Add to the circuit an LED and its limiting resistor so that the LED lights when V_{in} is less than the value calculated in part (a).

- (ii) Explain why the LED functions in the position you have drawn it.

.....

.....

- (iii) Calculate the minimum value for the limiting resistor with the LED. Assume that the LED has a voltage drop of 2.0 V across it when emitting and a maximum current of 25 mA through it.

.....

.....

.....

(5 marks)

- (c) An LDR is now connected between the points A and B in the circuit. The characteristic of the LDR is shown below.

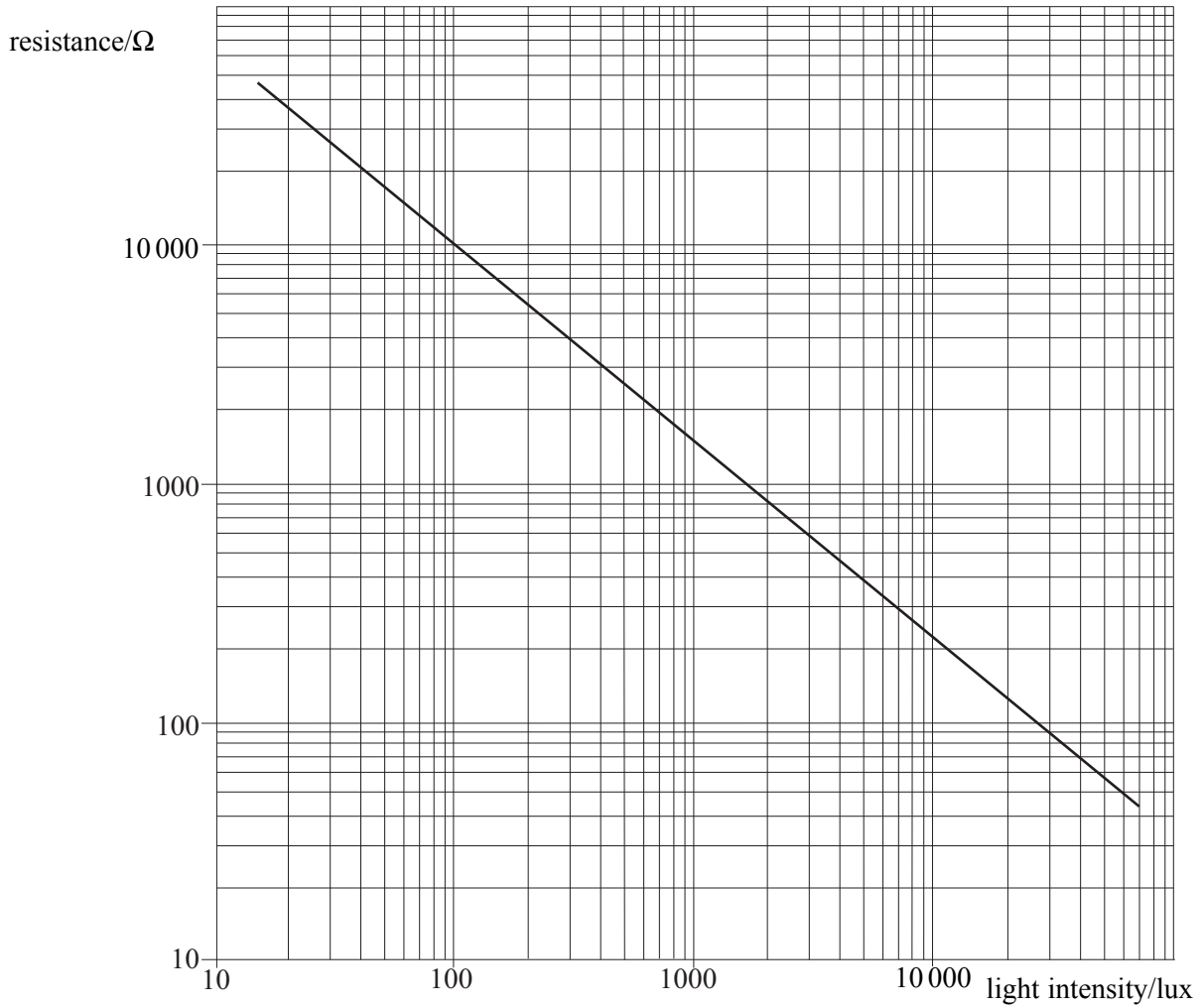

Determine the light intensity at which the LED switches.

.....

.....

.....

.....

.....

(3 marks)

10

QUALITY OF WRITTEN COMMUNICATION (2 marks)

2

END OF QUESTIONS