

Surname						Other Names					
Centre Number						Candidate Number					
Candidate Signature											

Leave blank

General Certificate of Education
 January 2002
 Advanced Subsidiary Examination



PHYSICS (SPECIFICATION A)
Unit 3 Practical

PHA3/P

Tuesday 22 January 2002 Morning Session

<p>In addition to this paper you will require:</p> <ul style="list-style-type: none"> • a calculator, • a pencil and a ruler.
--

For Examiner's Use			
Number	Mark	Nmber	Mark
1			
2			
Total (Column 1)	→		
Total (Column 2)	→		
TOTAL			
Examiner's Initials			

Time allowed: 1 hour 45 minutes

Instructions

- Use a blue or black ball-point pen.
- Fill in the boxes at the top of this page.
- Answer **both** questions in the spaces provided. All working must be shown.
- Do all rough work in this book. Cross through any work you do not want marked.

Information

- The maximum mark for this paper is 30.
- Mark allocations are shown in brackets.
- The paper carries 15% of the total marks for Physics Advanced Subsidiary and carries 7½% of the total marks for Physics Advanced.
- A *Data Sheet* is provided on pages 3 and 4. You may wish to detach this perforated sheet at the start of the examination.
- You are expected to use a calculator where appropriate.
- You are advised to spend no more than 30 minutes on Question 1.

Data Sheet

- A perforated Data Sheet is provided as pages 3 and 4 of this question paper.
- This sheet may be useful for answering some of the questions in the examination.
- You may wish to detach this sheet before you begin work.

The data sheet replaces this page

The data sheet replaces this page

Answer **both** questions.

You are advised to spend no more than 30 minutes on Question 1.

- 1 Some physics students have been studying how elastic materials store energy when they are deformed. Their teacher uses the diagram shown in **Figure 1** to explain that an elastic cord will only return about 75% of the energy supplied to it.

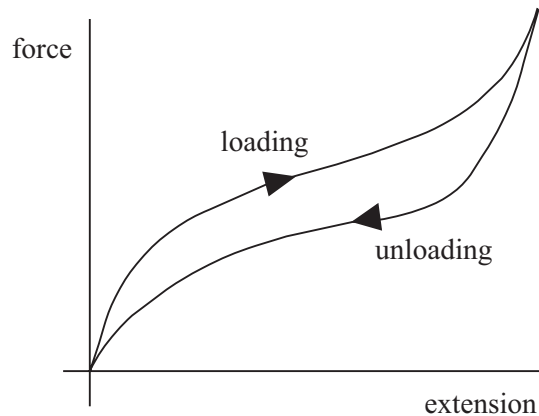

Figure 1

A catapult is an example of a system where energy is stored and then released from an elastic cord; the diagrams in **Figure 2** show a catapult at rest (left), storing maximum energy (centre) and releasing energy (right).

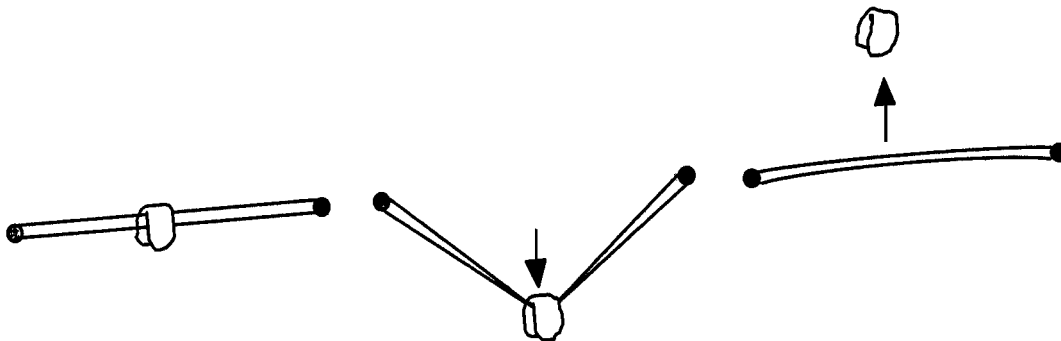

Figure 2

Design an experiment that would enable the students to find the fraction of the stored energy that is returned by the catapult. You should assume that the normal apparatus found in school physics laboratories is available to you.

You are advised to draw a suitable diagram of the arrangement you intend to use as part of your answer.

You should also include the following in your answer:

- The quantities you intend to measure and how you will measure them
- How you propose to use your measurements to determine the energy stored in the catapult and the **useful** energy released from the catapult
- The factors you will need to control and how you will do this
- How you could overcome any difficulties in obtaining reliable results.

Write your answers to Question 1 on **pages 6 and 7** of this booklet.

(8 marks)

Turn over ▶

A large rectangular area with a solid top and right border and a dotted bottom border, intended for writing.

TURN OVER FOR THE NEXT QUESTION

Turn over ▶

2 This question is divided into parts (a) to (f) printed on pages 8 to 12.

In this experiment you are required to investigate the potential difference across parts of a resistor network as the current in the circuit is varied.

No description of the experiment is required.

You are provided with the circuit shown below and a separate voltmeter.

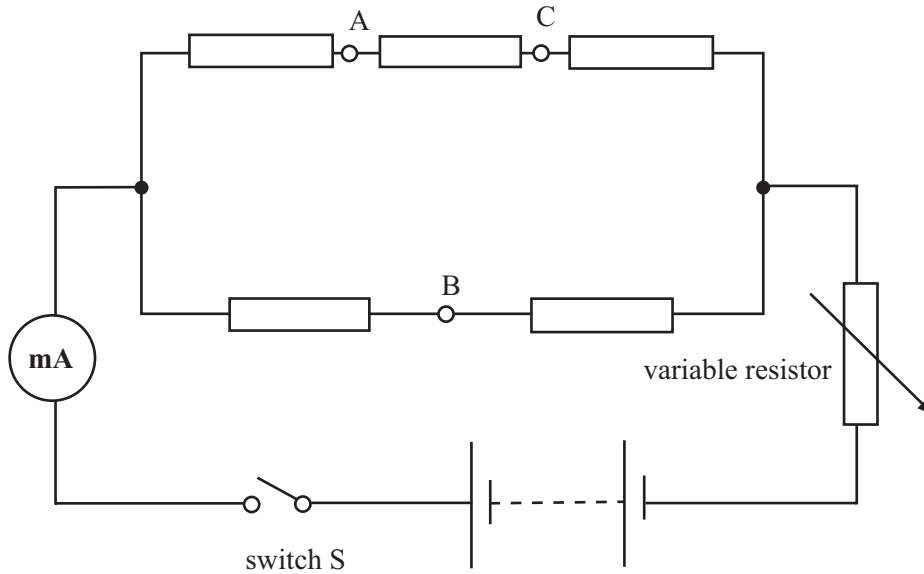

- (a) (i) Close the switch S and set the variable resistor to its **maximum** resistance. Read and record the current I_1 .

$$I_1 = \dots\dots\dots$$

- (ii) Set the variable resistor to its **minimum** resistance and read and record the current I_2 .

$$I_2 = \dots\dots\dots$$

- (iii) Calculate $\frac{I_2}{I_1}$.

$$\frac{I_2}{I_1} = \dots\dots\dots$$

- (d) Using the grid **on page 11** of this booklet, plot a graph of your results. Choose a suitable scale for the vertical axis that will allow all your values for V_{AB} **and** V_{CB} to be plotted **on a single vertical axis** with the corresponding values for I on the horizontal axis.

(6 marks)

- (e) (i) Measure and record the gradient, G_1 , of the graph you plotted for V_{AB} against I .

$$G_1 = \dots\dots\dots$$

- (ii) Measure and record the gradient, G_2 , of the graph you plotted for V_{CB} against I .

$$G_2 = \dots\dots\dots$$

- (iii) Calculate $\frac{G_1}{G_2}$.

$$\frac{G_1}{G_2} = \dots\dots\dots$$

(3 marks)

QUESTION 2 CONTINUES ON PAGE 12

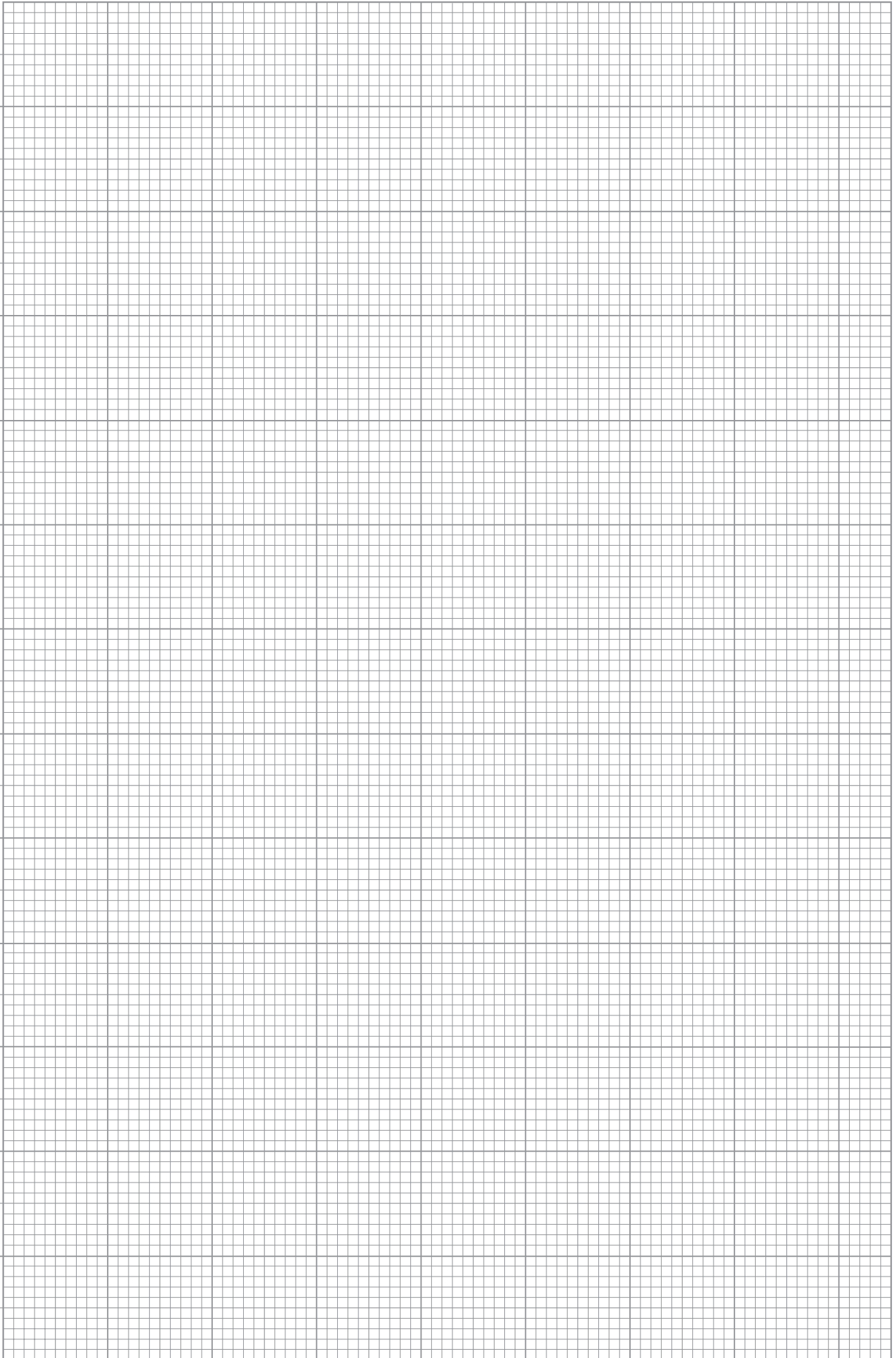

- (f) (i) Justify the number of readings you took for V_{AB} and V_{CB} .

.....
.....
.....
.....

- (ii) With reference to your experimental results in part (a), suggest how the maximum resistance of the variable resistor compares with the resistance of the network of resistors.

.....
.....
.....
.....
.....
.....

- (iii) If the experiment were repeated using a variable resistor of **smaller maximum resistance**, explain what effect, if any, this would have on the values of the currents I_1 and I_2 .

.....
.....
.....
.....
.....
.....

(6 marks)

END OF QUESTIONS