



GCE AS/A level

0980/01

MATHEMATICS – M1

Mechanics

A.M. TUESDAY, 21 June 2016

1 hour 30 minutes plus your additional time allowance

ADDITIONAL MATERIALS

In addition to this examination paper, you will need:

a 12 page answer book;
a Formula Booklet;
a calculator.

INSTRUCTIONS TO CANDIDATES

Use black ink, black ball-point pen or your usual method.

Answer ALL questions.

Take g as 9.8 ms^{-2} .

Sufficient working must be shown to demonstrate the MATHEMATICAL method employed.

INFORMATION FOR CANDIDATES

The number of marks is given in brackets at the end of each question or part-question.

You are reminded of the necessity for good English and orderly presentation in your answers.

1. A lift, starting from rest, descends with a uniform acceleration of 3.2 ms^{-2} until it reaches a speed of 12 ms^{-1}

It then travels at a constant speed of 12 ms^{-1} for a short time and finally, it is brought to rest with a uniform deceleration of 2.4 ms^{-2}

A person of mass 65 kg is standing in the lift. Calculate the magnitude of the reaction of the floor of the lift on the person during each of the three stages of the motion.

[5 marks]

2. The diagram shows two objects, ***A*** and ***B***, of mass **2 kg** and **5 kg** respectively, connected by a light inextensible string passing over a smooth fixed pulley. Initially, the objects are held at rest with the string taut. The system is then released.

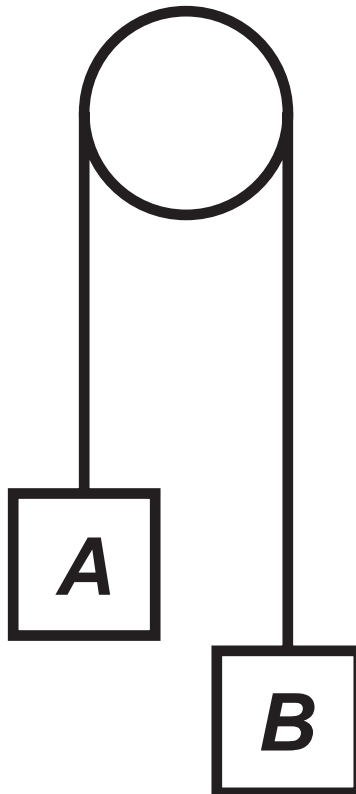

2(a) Find the magnitude of the acceleration of **A** and the tension in the string.

[7 marks]

(b) Before the object **A** reaches the pulley and 2 seconds after the system is released, the string breaks.

(i) Find the speed of **A** when the string breaks.

(ii) Given that **A** does not reach the pulley in the subsequent motion and that **A** is **18.9 m** above the ground when the string breaks, determine the time taken for **A** to reach the ground.

[6 marks]

3. Two spheres, **A** and **B**, of equal radii, lie at rest on a smooth horizontal surface.

Sphere **A** has mass **3 kg** and sphere **B** has mass **11 kg**

Sphere **A** is given an impulse **$J \text{ N s}$** so that it moves with speed **4 ms^{-1}** towards sphere **B** and collides directly with it.

The coefficient of restitution between the

spheres is $\frac{1}{4}$

- (a) Find the value of **J**

[1 mark]

- (b) Determine the speed of **A** and the speed of **B** after the collision.

[7 marks]

3(c) After the first collision, sphere ***B*** collides with a wall, which is perpendicular to its direction of motion.

It rebounds with speed $\frac{6}{7} \text{ ms}^{-1}$

Determine the coefficient of restitution between sphere ***B*** and the wall.

[2 marks]

4. A man drives a car along a straight road. As he passes the point **A**, the car is travelling at a constant speed of **30 ms^{-1}** . He continues at the speed of **30 ms^{-1}** for **5** minutes until he approaches a built-up area, when he applies a constant deceleration for **20** seconds until the car slows down to a speed of **16 ms^{-1}** .

On reaching the speed of **16 ms^{-1}** , he sees his destination point **B** and applies a constant deceleration for **8 s** until the car stops at **B**.

- (a) Sketch a velocity-time graph for the journey between **A** and **B**.

[4 marks]

- (b) Find the distance between **A** and **B**.

[4 marks]

5. The diagram opposite shows four horizontal forces of magnitude **12 N**, **8 N**, **7 N** and **15 N** acting on a particle ***P***, of mass **4 kg**. Directions are as shown in the diagram opposite.

Calculate the magnitude of the resultant of the forces, giving your answer correct to one decimal place, and determine the magnitude of the acceleration of ***P***.

[7 marks]

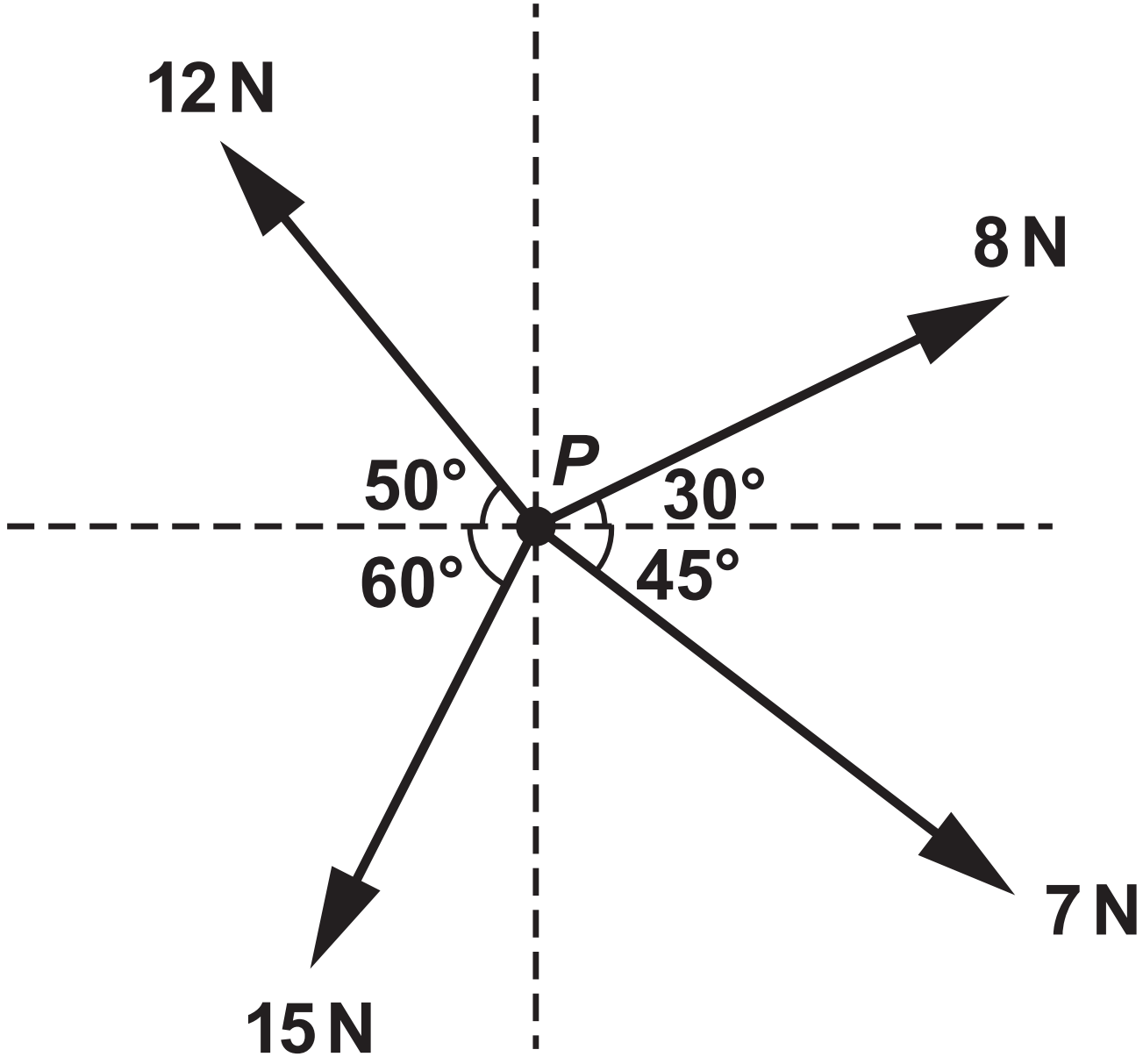

6. A uniform rod AB is of mass 8 kg and length 6 m

It is suspended horizontally in equilibrium by means of two vertical light strings attached to the rod AB at point C and point D on the rod, where $AC = 1.6 \text{ m}$ and $AD = 4.8 \text{ m}$

Calculate the tension in the string at C and the tension in the string at D

[7 marks]

7. A sledge of mass **12 kg** is being pulled up a rough slope, inclined at an angle of **20°** to the horizontal, by a rope which is inclined at an angle of **10°** to the slope.

The tension in the rope is constant at **80 N**

The coefficient of friction between the slope and the sledge is **0.2**

- (a) Calculate the frictional force on the sledge.
[4 marks]
- (b) Determine the magnitude of the acceleration of the sledge.
[4 marks]

8. A car is travelling along a straight road ABC with uniform acceleration $a \text{ ms}^{-2}$

The distance AC is 460 m

The time taken by the car to travel from A to B is 6 s and the time taken to travel from B to C is 14 s

At A the speed of the car is $u \text{ ms}^{-1}$ and at B , the speed of the car is 17 ms^{-1}

Find the value of a and the value of u .

[7 marks]

9. The diagram opposite shows a lamina ABC consisting of a right-angled triangle with a circular section of radius 2 cm removed.

The centre O of the circular section is 4 cm from AC and 3 cm from AB

The lamina is made from a uniform material.

A particle D , of mass three times that of the removed circular section, is attached to the

midpoint of BC

Dimensions, in cm , are as shown in the diagram.

Find the distances of the centre of mass of the lamina ABC , with D attached, from AC and from AB

Give each answer correct to two decimal places.

[10 marks]

Diagram for Question 9

