

**ADVANCED GCE UNIT
MATHEMATICS (MEI)**

Mechanics 3

MONDAY 21 MAY 2007

4763/01

Morning
Time: 1 hour 30 minutes

Additional materials:
Answer booklet (8 pages)
Graph paper
MEI Examination Formulae and Tables (MF2)

INSTRUCTIONS TO CANDIDATES

- Write your name, centre number and candidate number in the spaces provided on the answer booklet.
- Answer **all** the questions.
- You are permitted to use a graphical calculator in this paper.
- Final answers should be given to a degree of accuracy appropriate to the context.
- The acceleration due to gravity is denoted by $g \text{ m s}^{-2}$. Unless otherwise instructed, when a numerical value is needed, use $g = 9.8$.

INFORMATION FOR CANDIDATES

- The number of marks is given in brackets [] at the end of each question or part question.
- The total number of marks for this paper is 72.

ADVICE TO CANDIDATES

- Read each question carefully and make sure you know what you have to do before starting your answer.
- You are advised that an answer may receive **no marks** unless you show sufficient detail of the working to indicate that a correct method is being used.

- 1 (a) (i) Write down the dimensions of the following quantities.

Velocity

Acceleration

Force

Density (which is mass per unit volume)

Pressure (which is force per unit area) [5]

For a fluid with constant density ρ , the velocity v , pressure P and height h at points on a streamline are related by Bernoulli's equation

$$P + \frac{1}{2}\rho v^2 + \rho gh = \text{constant},$$

where g is the acceleration due to gravity.

- (ii) Show that the left-hand side of Bernoulli's equation is dimensionally consistent. [4]
- (b) In a wave tank, a float is performing simple harmonic motion with period 3.49 s in a vertical line. The height of the float above the bottom of the tank is h m at a time t s. When $t = 0$, the height has its maximum value. The value of h varies between 1.6 and 2.2.
- (i) Sketch a graph showing how h varies with t . [2]
- (ii) Express h in terms of t . [4]
- (iii) Find the magnitude and direction of the acceleration of the float when $h = 1.7$. [3]

- 2 A fixed hollow sphere with centre O has an inside radius of 2.7 m. A particle P of mass 0.4 kg moves on the smooth inside surface of the sphere.

At first, P is moving in a horizontal circle with constant speed, and OP makes a constant angle of 60° with the vertical (see Fig. 2.1).

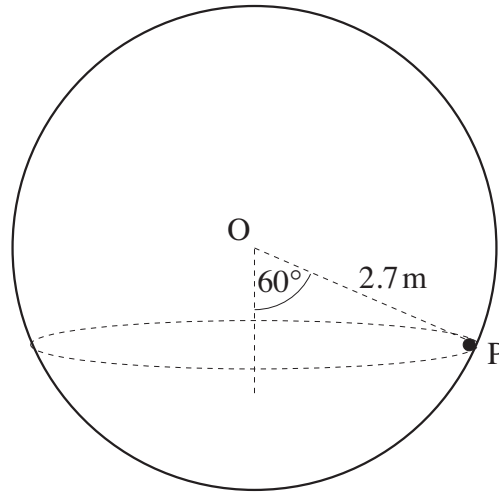

Fig. 2.1

- (i) Find the normal reaction acting on P . [2]
 (ii) Find the speed of P . [4]

The particle P is now placed at the lowest point of the sphere and is given an initial horizontal speed of 9 m s^{-1} . It then moves in part of a vertical circle. When OP makes an angle θ with the upward vertical and P is still in contact with the sphere, the speed of P is $v \text{ m s}^{-1}$ and the normal reaction acting on P is $R \text{ N}$ (see Fig. 2.2).

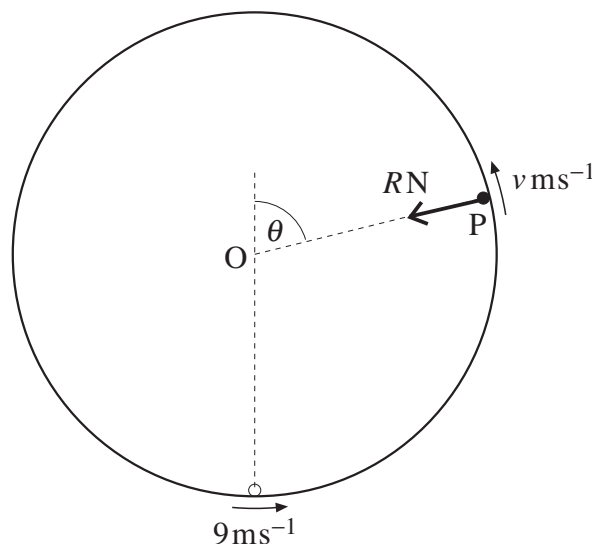

Fig. 2.2

- (iii) Find v^2 in terms of θ . [3]
 (iv) Show that $R = 4.16 - 11.76 \cos \theta$. [5]
 (v) Find the speed of P at the instant when it leaves the surface of the sphere. [4]

3 A light elastic string has natural length 1.2 m and stiffness 637 N m^{-1} .

- (i) The string is stretched to a length of 1.3 m. Find the tension in the string and the elastic energy stored in the string. [3]

One end of this string is attached to a fixed point A. The other end is attached to a heavy ring R which is free to move along a smooth vertical wire. The shortest distance from A to the wire is 1.2 m (see Fig. 3).

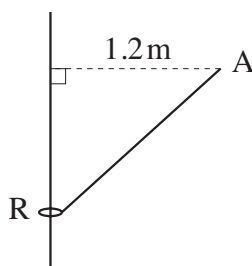

Fig. 3

The ring is in equilibrium when the length of the string AR is 1.3 m.

- (ii) Show that the mass of the ring is 2.5 kg. [4]

The ring is given an initial speed $u \text{ m s}^{-1}$ vertically downwards from its equilibrium position. It first comes to rest, instantaneously, in the position where the length of AR is 1.5 m.

- (iii) Find u . [7]
- (iv) Determine whether the ring will rise above the level of A. [4]

- 4 (a) The region bounded by the curve $y = x^3$ for $0 \leq x \leq 2$, the x -axis and the line $x = 2$, is occupied by a uniform lamina. Find the coordinates of the centre of mass of this lamina. [8]
- (b) The region bounded by the circular arc $y = \sqrt{4 - x^2}$ for $1 \leq x \leq 2$, the x -axis and the line $x = 1$, is rotated through 2π radians about the x -axis to form a uniform solid of revolution, as shown in Fig. 4.1.

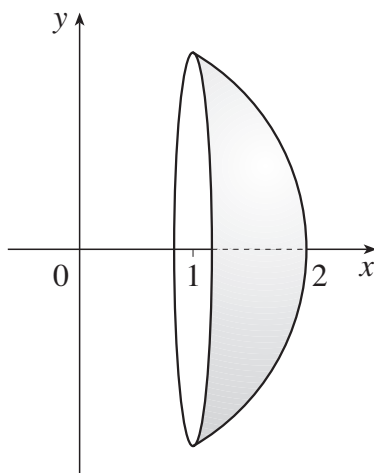

Fig. 4.1

- (i) Show that the x -coordinate of the centre of mass of this solid of revolution is 1.35. [6]

This solid is placed on a rough horizontal surface, with its flat face in a vertical plane. It is held in equilibrium by a light horizontal string attached to its highest point and perpendicular to its flat face, as shown in Fig. 4.2.

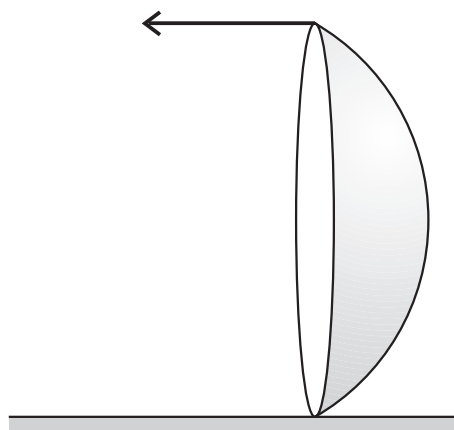

Fig. 4.2

- (ii) Find the least possible coefficient of friction between the solid and the horizontal surface. [4]

6
BLANK PAGE

7
BLANK PAGE

Permission to reproduce items where third-party owned material protected by copyright is included has been sought and cleared where possible. Every reasonable effort has been made by the publisher (OCR) to trace copyright holders, but if any items requiring clearance have unwittingly been included, the publisher will be pleased to make amends at the earliest possible opportunity.

OCR is part of the Cambridge Assessment Group. Cambridge Assessment is the brand name of University of Cambridge Local Examinations Syndicate (UCLES), which is itself a department of the University of Cambridge.

**Mark Scheme 4763
June 2007**

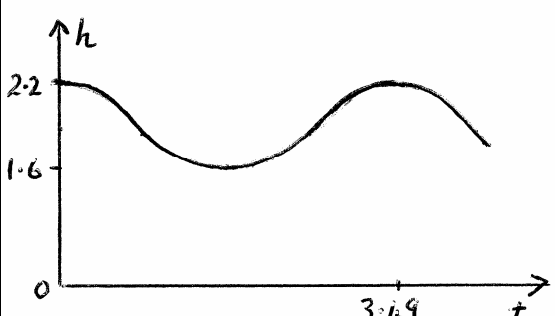
1(a)(i)	<p>[Velocity] = LT^{-1} [Acceleration] = LT^{-2} [Force] = MLT^{-2} [Density] = ML^{-3} [Pressure] = $ML^{-1}T^{-2}$</p>	<p>B1 B1 B1 B1 B1</p> <p style="text-align: right;">5</p>	<p>(Deduct 1 mark if answers given as ms^{-1}, ms^{-2}, $kgms^{-2}$ etc)</p>
(ii)	<p>[P] = $ML^{-1}T^{-2}$ [$\frac{1}{2}\rho v^2$] = $(ML^{-3})(LT^{-1})^2$ = $ML^{-1}T^{-2}$ [ρgh] = $(ML^{-3})(LT^{-2})(L) = ML^{-1}T^{-2}$ All 3 terms have the same dimensions</p>	<p>M1 A1 A1 E1</p> <p style="text-align: right;">4</p>	<p>Finding dimensions of 2nd or 3rd term</p> <p>Allow e.g. 'Equation is dimensionally consistent' following correct work</p>
(b)(i)		<p>M1 A1</p> <p style="text-align: right;">2</p>	<p>For a 'cos' curve (starting at the highest point)</p> <p>Approx correct values marked on both axes</p>
(ii)	<p>Period $\frac{2\pi}{\omega} = 3.49$ $\omega = 1.8$</p> <p>$h = 1.9 + 0.3 \cos 1.8t$</p>	<p>M1 A1 M1 F1</p> <p style="text-align: right;">4</p>	<p>Accept $\frac{2\pi}{3.49}$</p> <p>For $h = c + a \cos/\sin$ with either $c = \frac{1}{2}(1.6 + 2.2)$ or $a = \frac{1}{2}(2.2 - 1.6)$</p>
(iii)	<p>When $h = 1.7$, float is 0.2 m below centre Acceleration is $\omega^2 x = 1.8^2 \times 0.2$ = 0.648 ms^{-2} upwards</p> <hr style="border-top: 1px dashed black;"/> <p>OR When $h = 1.7$, $\cos 1.8t = -\frac{2}{3}$ ($1.8t = 2.30$, $t = 1.28$) Acceleration $\ddot{h} = -0.3 \times 1.8^2 \cos 1.8t$ M1 = $-0.3 \times 1.8^2 \times (-\frac{2}{3})$ A1 = 0.648 ms^{-2} upwards A1 cao</p>	<p>M1A1 A1 cao</p> <p style="text-align: right;">3</p>	<p>Award M1 if there is at most one error</p>

2 (i)	$R \cos 60 = 0.4 \times 9.8$ Normal reaction is 7.84 N	M1 A1 2	Resolving vertically (e.g. $R \sin 60 = mg$ is M1A0 $R = mg \cos 60$ is M0)
(ii)	$R \sin 60 = 0.4 \times \frac{v^2}{2.7 \sin 60}$ Speed is 6.3 ms^{-1}	M1 M1 A1 A1 cao 4	Horizontal equation of motion Acceleration $\frac{v^2}{r}$ (M0 for $\frac{v^2}{2.7}$)
	OR $R \sin 60 = 0.4 \times (2.7 \sin 60) \omega^2$ $\omega = 2.694$ $v = (2.7 \sin 60) \omega$ Speed is 6.3 ms^{-1}	M1 A1 M1 A1 cao	Horizontal equation of motion or $R = 0.4 \times 2.7 \times \omega^2$ For $v = r\omega$ (M0 for $v = 2.7\omega$)
(iii)	By conservation of energy, $\frac{1}{2} \times 0.4 \times (9^2 - v^2) = 0.4 \times 9.8 \times (2.7 + 2.7 \cos \theta)$ $81 - v^2 = 52.92 + 52.92 \cos \theta$ $v^2 = 28.08 - 52.92 \cos \theta$	M1 A1 A1 3	Equation involving KE and PE Any (reasonable) correct form e.g. $v^2 = 81 - 52.92(1 + \cos \theta)$
(iv)	$R + 0.4 \times 9.8 \cos \theta = 0.4 \times \frac{v^2}{2.7}$ $R + 3.92 \cos \theta = \frac{0.4}{2.7} (28.08 - 52.92 \cos \theta)$ $R + 3.92 \cos \theta = 4.16 - 7.84 \cos \theta$ $R = 4.16 - 11.76 \cos \theta$	M1 A1 M1 A1 E1 5	Radial equation with 3 terms Substituting expression for v^2 SR If θ is taken to the downward vertical, maximum marks are: M1A0A0 in (iii) M1A1M1A1E0 in (iv)
(v)	Leaves surface when $R = 0$ $\cos \theta = \frac{4.16}{11.76}$ $v^2 = 28.08 - 52.92 \times \frac{4.16}{11.76}$ (= 9.36) Speed is 3.06 ms^{-1}	M1 A1 M1 A1 cao 4	Dependent on previous M1 or using $mg \cos \theta = \frac{mv^2}{r}$

3 (i)	Tension is $637 \times 0.1 = 63.7 \text{ N}$ Energy is $\frac{1}{2} \times 637 \times 0.1^2$ $= 3.185 \text{ J}$	B1 M1 A1 3	
(ii)	Let θ be angle between RA and vertical $\cos \theta = \frac{5}{13}$ ($\theta = 67.4^\circ$) $T \cos \theta = mg$ $63.7 \times \frac{5}{13} = m \times 9.8$ Mass of ring is 2.5 kg	B1 M1 A1 E1 4	Resolving vertically
(iii)	Loss of PE is $2.5 \times 9.8 \times (0.9 - 0.5)$ EE at lowest point is $\frac{1}{2} \times 637 \times 0.3^2$ ($= 28.665$) By conservation of energy, $2.5 \times 9.8 \times 0.4 + \frac{1}{2} \times 2.5u^2 = \frac{1}{2} \times 637 \times 0.3^2 - 3.185$ $9.8 + 1.25u^2 = 25.48$ $u^2 = 12.544$ $u = 3.54$	M1 A1 M1 A1 M1 F1 A1 cao 7	Considering PE or PE at start and finish Award M1 if not more than one error Equation involving KE, PE and EE
(iv)	From lowest point to level of A, Loss of EE is 28.665 Gain in PE is $2.5 \times 9.8 \times 0.9 = 22.05$ Since $28.665 > 22.05$, Ring will rise above level of A	M1 M1 M1 A1 cao 4	EE at 'start' and at level of A PE at 'start' and at level of A (For M2 it must be the same 'start') Comparing EE and PE (<i>or equivalent,</i> <i>e.g. $\frac{1}{2}mu^2 + 3.185 = mg \times 0.5 + \frac{1}{2}mv^2$)</i>) Fully correct derivation
			SR If 637 is used as modulus, maximum marks are: (i) B0M1A0 (ii) B1M1A1E0 (iii) M1A1M1A1M1F1A0 (iv) M1M1M1A0

<p>4 (a)</p>	<p>Area is $\int_0^2 x^3 dx = \left[\frac{1}{4}x^4 \right]_0^2 = 4$</p> <p>$\int xy dx = \int_0^2 x^4 dx$ $= \left[\frac{1}{5}x^5 \right]_0^2 = 6.4$</p> <p>$\bar{x} = \frac{6.4}{4} = 1.6$</p> <p>$\int \frac{1}{2}y^2 dx = \int_0^2 \frac{1}{2}x^6 dx$ $= \left[\frac{1}{14}x^7 \right]_0^2 = \frac{64}{7}$</p> <p>$\bar{y} = \frac{\int \frac{1}{2}y^2 dx}{\int y dx}$ $= \frac{\frac{64}{7}}{4} = \frac{16}{7}$</p>	<p>B1</p> <p>M1</p> <p>A1</p> <p>A1</p> <p>M1</p> <p>A1</p> <p>M1</p> <p>A1</p>	<p>Condone omission of $\frac{1}{2}$</p> <p>Accept 2.3 from correct working</p> <p>8</p>
<p>(b)(i)</p>	<p>Volume is $\int \pi y^2 dx = \int_1^2 \pi(4 - x^2) dx$ $= \pi \left[4x - \frac{1}{3}x^3 \right]_1^2 = \frac{5}{3}\pi$</p> <p>$\int \pi x y^2 dx = \int_1^2 \pi x(4 - x^2) dx$ $= \pi \left[2x^2 - \frac{1}{4}x^4 \right]_1^2 = \frac{9}{4}\pi$</p> <p>$\bar{x} = \frac{\int \pi x y^2 dx}{\int \pi y^2 dx}$ $= \frac{\frac{9}{4}\pi}{\frac{5}{3}\pi} = \frac{27}{20} = 1.35$</p>	<p>M1</p> <p>A1</p> <p>M1</p> <p>A1</p> <p>M1</p> <p>E1</p>	<p>π may be omitted throughout</p> <p>For $\frac{5}{3}$</p> <p>For $\frac{9}{4}$</p> <p>Must be fully correct</p> <p>6</p>
<p>(ii)</p>	<p>Height of solid is $h = 2\sqrt{3}$</p> <p>$Th = mg \times 0.35$ $F = T = 0.101mg, R = mg$</p> <p>Least coefficient of friction is $\frac{F}{R} = 0.101$</p>	<p>B1</p> <p>M1</p> <p>F1</p> <p>A1</p>	<p>Taking moments</p> <p>Must be fully correct (e.g. A0 if $m = \frac{5}{3}\pi$ is used)</p> <p>4</p>

4763: Mechanics 3

General Comments

The standard of work on this paper was very high. Most candidates found it to be a straightforward test of the topics, and there were many excellent scripts; about half the candidates scored 60 marks or more (out of 72). There were some weaker candidates, but very few scored less than 30 marks, and almost all appeared to have sufficient time to complete all that they could do. Circular motion was the only topic which seemed to cause significant difficulties for a large number of candidates.

Comments on Individual Questions

- 1 This question, on **dimensional analysis and simple harmonic motion**, was the best answered question, with an average mark of about 16 (out of 18).
- (a)(i) Almost every candidate gave the dimensions correctly.
 - (a)(ii) The great majority of candidates found the dimensions of each term correctly, although some did not explain how their working had demonstrated the required result. A simple statement that the equation is consistent was sufficient to earn the final mark, but ideally some reference to all terms having the same dimensions should be made.
 - (b)(i) The graph showing the variation of the depth was usually drawn correctly, although there was sometimes no indication of scale on the time axis.
 - (b)(ii) The equation for h was found correctly by about half the candidates. The value of \square was usually calculated correctly from the period, but the amplitude was sometimes 0.6 instead of 0.3, and the central value 1.9 was quite often omitted.
 - (b)(iii) Most candidates used $\omega^2 x$ to find the magnitude of the acceleration, but x was very often taken to be 1.7 instead of 0.2. Other methods, such as differentiating the equation for h from part (b)(ii), were even more prone to errors. The direction was often given wrongly, and sometimes omitted.
- 2 This question, on **circular motion**, was the worst answered question, with an average mark of about 13; but even so about 30% of the candidates did score full marks. The horizontal circle (parts (i) and (ii)) caused more problems than the vertical circle.
- (i) Although this was answered correctly by most candidates, a very common error was resolving parallel to PO ($R = mg \cos 60$) instead of vertically ($R \cos 60 = mg$).
 - (ii) Most attempted to use v^2 / r for the acceleration, but a very common error was to take the radius to be 2.7 instead of $2.7 \sin 60$, and some did not consider the horizontal component of the normal reaction.
 - (iii) This was quite well answered, although some candidates did not realise that they only needed to use conservation of energy.
 - (iv) Most candidates were able to set up the radial equation of motion and obtain the given result. A fairly common error was omission of the component of the weight.
 - (v) Most candidates understood that P leaves the surface when $R = 0$, although some

were unable to follow this with a correct calculation of the speed.

- 3 This question, on **elasticity**, was generally well understood, and the average mark was about 15.
- (i) Almost every candidate found the tension and the energy correctly.
 - (ii) The great majority of candidates realised that they should resolve vertically to find the mass of the ring.
 - (iii) Almost all candidates realised that they should consider energy, but very many failed to take sufficient care over the details. Common errors included the miscalculation (or omission) of the change in gravitational potential energy, forgetting about the initial elastic energy in the string, and sign errors in the energy equation.
 - (iv) Some assumed that the ring moves with simple harmonic motion, but the majority of candidates who attempted this part continued to consider energy, either from the lowest point or from the initial position. The most successful, and simplest, approach was to show that the ring has positive kinetic energy when it reaches the level of A; those who tried to find the highest point reached usually forgot that the string would become stretched again.
- 4 The methods required in this question, on **centres of mass**, were very well understood, apart from the last part. The average mark was about 14.
- (a) Most candidates found the centre of mass of the lamina correctly.
 - (b)(i) Most candidates obtained the centre of mass of the solid of revolution correctly.
 - (b)(ii) Although most candidates realised that they should take moments, there were not many completely correct solutions to this part. Common errors were miscalculating the height of the solid, and especially taking the moment of the weight about the point of contact to be $mg \times 1.35$ instead of $mg \times 0.35$.