

OXFORD CAMBRIDGE AND RSA EXAMINATIONS

**Advanced Subsidiary General Certificate of Education
Advanced General Certificate of Education**

MEI STRUCTURED MATHEMATICS

2620/1

Decision and Discrete Mathematics 1

Friday 16 JANUARY 2004 Afternoon 1 hour 20 minutes

Additional materials:

- Answer booklet
- Graph paper
- MEI Examination Formulae and Tables (MF12)

TIME 1 hour 20 minutes

INSTRUCTIONS TO CANDIDATES

- Write your Name, Centre Number and Candidate Number in the spaces provided on the answer booklet.
- Answer **all** questions.
- There is an **insert** for use in Questions **4(a)** and **5**.
- You are permitted to use a graphical calculator in this paper.

INFORMATION FOR CANDIDATES

- The allocation of marks is given in brackets [] at the end of each question or part question.
- You are advised that an answer may receive no marks unless you show sufficient detail of the working to indicate that a correct method is being used.
- Final answers should be given to a degree of accuracy appropriate to the context.
- The total number of marks for this paper is 60.

This question paper consists of 6 printed pages, 2 blank pages and an insert.

Section A

- 1 Thirteen books are to be stacked on shelves, each of which is of width 20 cm. The thicknesses of the books (in centimetres) are:

4 1 5.5 2 6 1.5 1.5 2 2 4 5 3 2.5

- (i) Arrange the books in increasing order of size. Taking the thinnest first, stack each book on the first shelf on which it will go. Show which size books go on which shelves using this method. [2]
- (ii) Arrange the books in order of size and use the first fit decreasing algorithm to stack them on shelves. Show which size books go on which shelves using this method. [2]
- (iii) Use the first fit algorithm on the original unsorted list to show that the books can be stacked on just two shelves. [1]
- 2 To study the distribution of a particular plant, a biologist wishes to choose metre squares (quadrats) from a rectangular plot of size 50 m by 30 m. She will use two-digit random numbers to choose the "columns" of her quadrats, and two-digit random numbers to choose the "rows" (see Fig. 2).

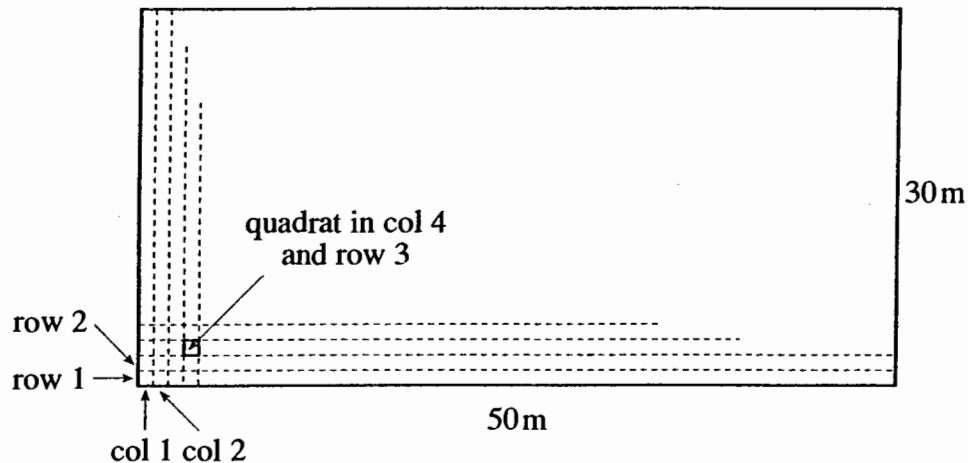

Fig. 2

- (i) Give a rule for using two-digit random numbers to choose a column from the 50 possible columns. [2]
- (ii) Give a rule for using two-digit random numbers to choose a row from the 30 possible rows. [3]

- 3 Fig. 3 shows part of a family tree. The vertices represent individuals, with males denoted by capital letters and females by lower case letters. An individual at a lower level of the graph is connected to one male at a higher level and to one female at a higher level – the individual's parents. Thus, for instance, *j*'s father's parents (*j*'s paternal grandparents) are *A* and *b*. *j*'s mother is *c*, and *j*'s mother's parents (*j*'s maternal grandparents) are not shown.

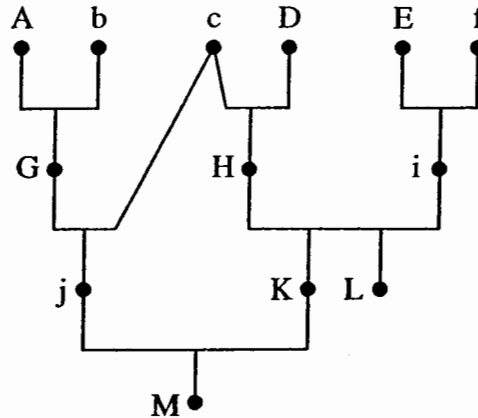

Fig. 3

- (i) List the four grandparents of *M*. [2]

The male *X* is not shown on the graph. *X*'s father is *M*'s paternal grandfather. *X*'s mother is *M*'s paternal grandmother.

- (ii) Who are *X*'s parents? [1]
- (iii) What is the relationship between *X* and *K*? [1]
- (iv) What grandparent is shared by *X* and *M*? [1]

Section B

4 There is an insert for part (a) of this question.

(a) Activity X is part of a large project. Fig. 4.1 shows that part of the project activity network relating to X. Each activity relating to X is shown, together with its relevant early event time or late event time. Activity durations are shown on the arcs.

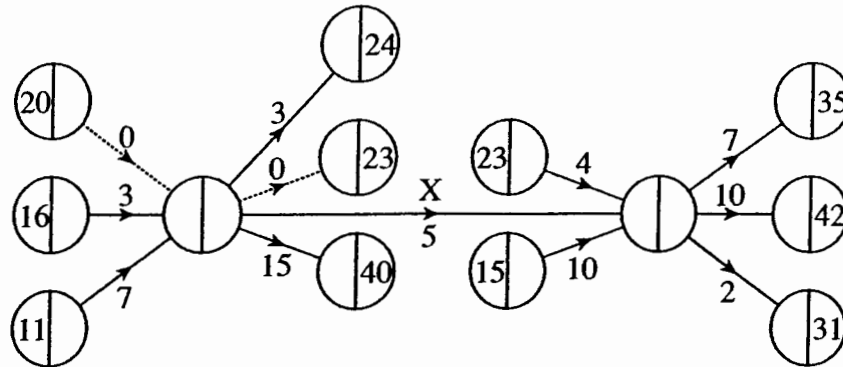

Fig. 4.1

(i) Compute the early time and the late time for the “i” event for X, and the early time and the late time for the “j” event for X. [4]

(ii) Calculate the total float for X and the independent float for X. [3]

(b) The precedences and durations for the activities of a project are shown in Table 4.2.

Activity	Immediate predecessors	Duration
A	–	2
B	–	3
C	A, B	4
D	B	2
E	C	7
F	C, D	3
G	C, D	5
H	F, G	2

Table 4.2

(i) Draw an activity-on-arc network for the project. [6]

(ii) Find the critical activities. [2]

- 5 There is an insert provided for this question. Answer all of the question on the insert.

Fig. 5 shows a network of villages together with the distances between them (in km) where a direct road link exists. There is a flyover taking the road connecting B and E over the road connecting C and D. There is no access between these roads.

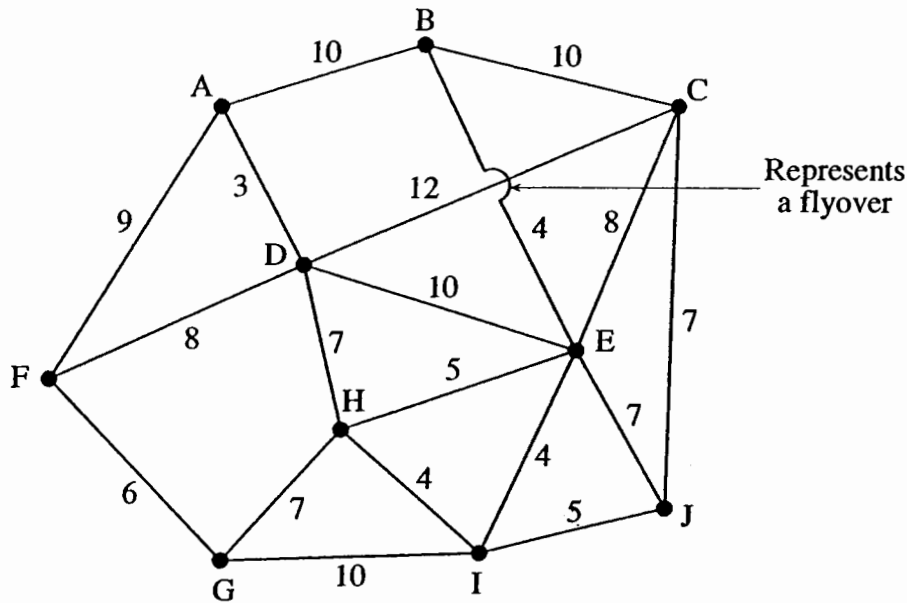

Fig. 5

- (i) Use Dijkstra's algorithm to find the shortest distance and the shortest route from A to J. [7]

The villages are to be connected by a system of water pipes, laid along roads.

- (ii) Use Prim's algorithm, starting at A, to find the best way to lay pipes so that the minimum total length of piping is used. Show the order in which you select arcs of the network. Draw your solution and give its total length. [5]

Access roads are now constructed at the flyover. This makes it possible to go from B to C or D, or from C to B or E, or from E to C or D, or from D to B or E. The flyover is midway between B and E and midway between C and D.

- (iii) Say how you would modify the network to model the new road layout at the flyover. [1]
- (iv) Find what effect, if any, the new road layout has on the shortest route from A to J. (You are not required to apply Dijkstra's algorithm to answer this question.) [1]
- (v) Find what effect, if any, the new road layout has on the pipe layout. (You are not required to apply an algorithm to answer this question.) [1]

6 John wants to spend £5 of his Christmas money on plain and milk chocolates.

He can buy surplus Christmas presentation boxes at £2 each. These each contain 25 plain chocolates and 25 milk chocolates.

He can buy loose plain chocolates at 6p each. He can also buy loose milk chocolates at 7p each.

John wants to have at least twice as many milk chocolates as plain chocolates.

Let x be the number of loose plain chocolates that John buys, y be the number of loose milk chocolates, and z the number of presentation boxes.

- (i) Give an expression in terms of x , y and z for the total number of chocolates that John buys. [2]
- (ii) Give an expression in terms of x , y and z for the cost of John's purchases. [2]
- (iii) Explain why the constraint that there should be at least twice as many milk chocolates as plain chocolates can be written as $y \geq 25z + 2x$. [1]

John wishes to maximise the number of chocolates he can buy, subject to his £5 limit and subject to buying at least twice as many milk chocolates as plain chocolates.

- (iv) Draw a graph to show that, if $z = 2$, then there is no feasible solution to the problem. [3]
- (v) Use a graphical method to solve the problem when $z = 1$. Show that John can purchase 93 chocolates in total, and give all of the available solutions. [7]

Candidate Name	Centre Number	Candidate Number



OXFORD CAMBRIDGE AND RSA EXAMINATIONS

**Advanced Subsidiary General Certificate of Education
Advanced General Certificate of Education**

MEI STRUCTURED MATHEMATICS

2620/1

Decision and Discrete Mathematics 1

INSERT

Friday

16 JANUARY 2004

Afternoon

1 hour 20 minutes

INSTRUCTIONS TO CANDIDATES

- This insert should be used in Questions 4(a) and 5.
- Write your Name, Centre Number and Candidate Number in the spaces provided at the top of this page and attach it to your answer booklet.

This insert consists of 3 printed pages and 1 blank page.

Insert for question 4(a).

(i)

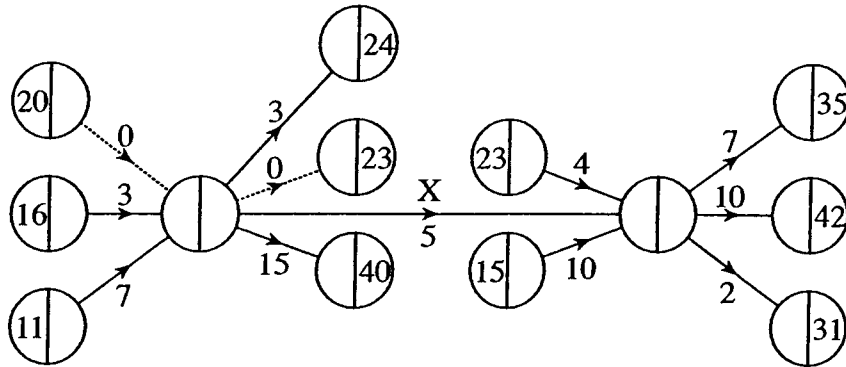

(ii) Total float for activity X: _____

Independent float for activity X: _____

Spare copy of diagram. (You do not need to use this.)

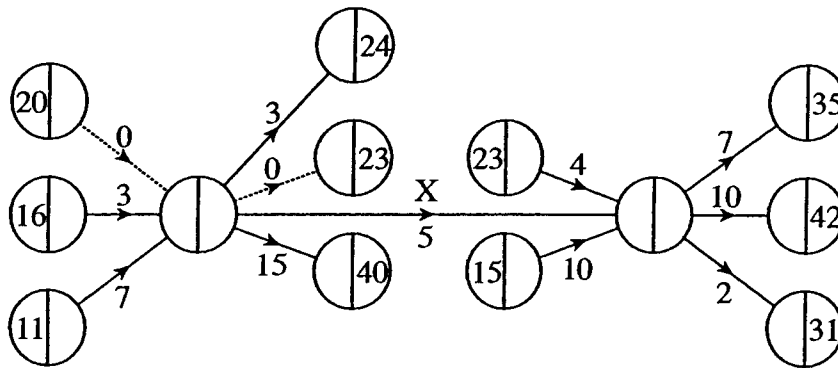

Insert for question 5.

(i)

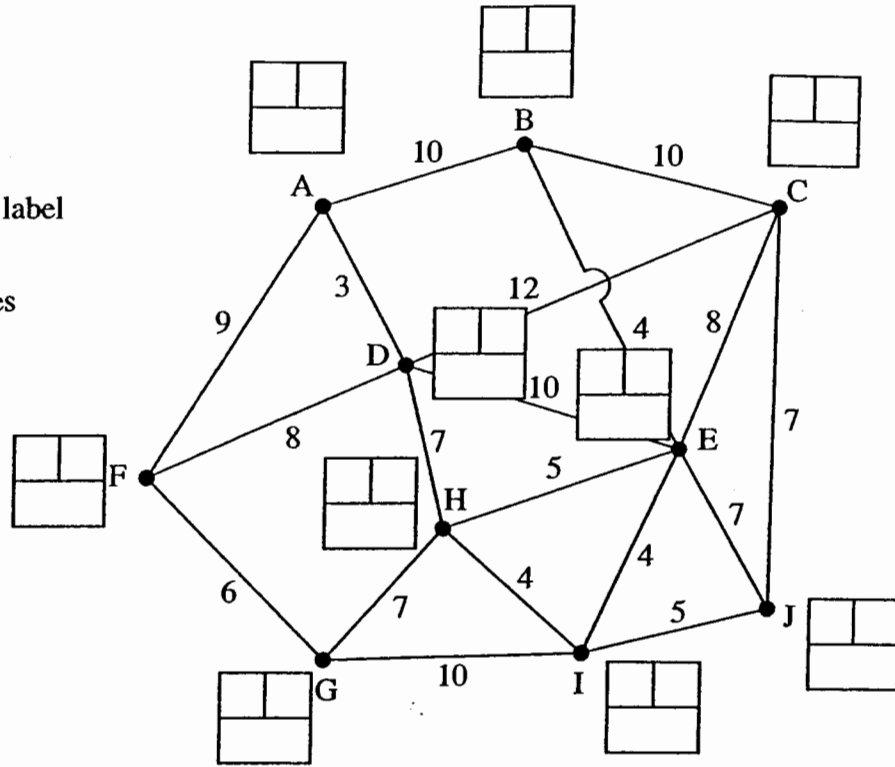
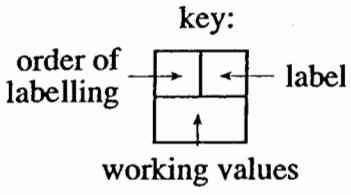

Shortest distance: _____ Shortest route: _____

(ii) Order of selection of arcs: _____

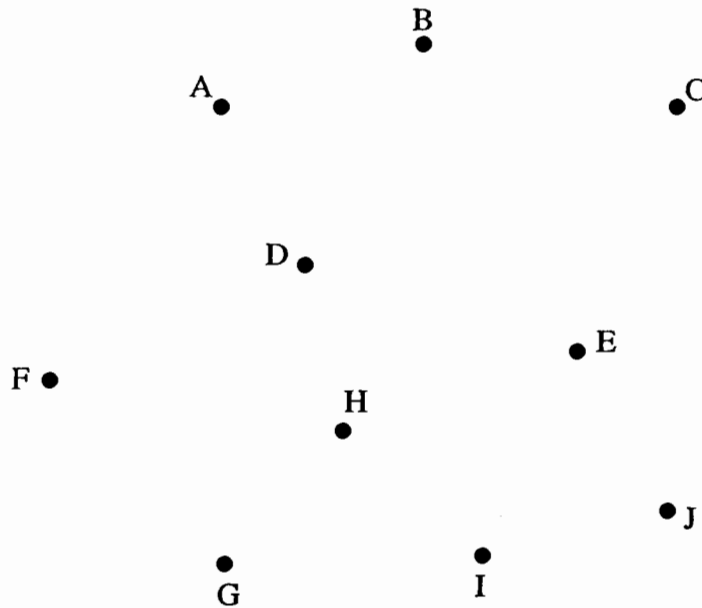

Total length: _____

(iii) _____

(iv) _____

(v) _____

Mark Scheme

1.

(i) 1, 1.5, 1.5, 2, 2, 2, 2.5, 3, 4 4, 5, 5.5 6	M1 A1
(ii) 6, 5.5, 5, 3 4, 4, 2.5, 2, 2, 2, 1.5, 1.5 1	M1 for 3 on shelf 1 A1
(iii) 4, 1, 5.5, 2, 6, 1.5 1.5, 2, 2, 4, 5, 3, 2.5	B1

2.

(i) 00 or 01 – col 1 02 or 03 – col 2 ... etc.	M1 A1
(ii) 00 or 01 or 02 – row 1 03 or 04 or 05 – row 2 ... 87 or 88 or 89 – row 30 90 to 99 – reject	M1 missing some A1 correct number missed A1 rest OK

3.

(i) (G, c) and (H, i)	B1 B1
(ii) H and i	B1
(iii) brothers	B1
(iv) c	B1

4.

<p>(a) (i)</p>	<p>B1 B1 B1 B1</p>
<p>(ii) total float = $28 - 20 - 5 = 3$ independent float = $27 - 21 - 5 = 1$</p>	<p>B1 \checkmark(if not 0) M1 A1 \checkmark(if different)</p>
<p>(b) (i)</p>	<p>M1 activity on arc A1 start and end M1 dummies used A1 C & D OK A1 F & G OK A1 rest</p>
<p>(ii) B, C, E G, H</p>	<p>B1 B1 (cao)</p>

5.

<p>(i)</p> <p>Distance: 19 Route: A D H I J</p>	<p>M1 Dijkstra A1 order of labelling A2 labels (-1 each error) A1 working values</p>
<p>(ii) AD DH HI IE EB IJ JC HG GF (or HG GF JC)</p> <p>Total length = 47</p>	<p>B1 B1</p> <p>M1 Prim A2 order (-1 each error)</p> <p>B1</p>
<p>(iii) Make the flyover into a vertex, X.</p>	<p>B1</p>
<p>(iv) ADXEJ has distance 18</p>	<p>B1</p>
<p>(v) X comes in at no cost, but XC (6) can replace JC (7), or XD (6) can replace DH (7) (or both).</p>	<p>B1</p>

6.

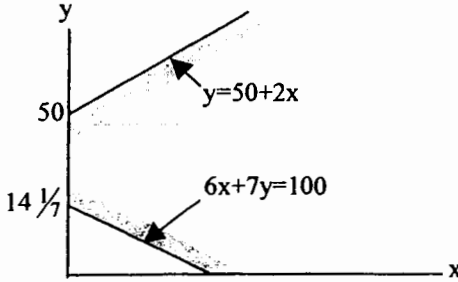
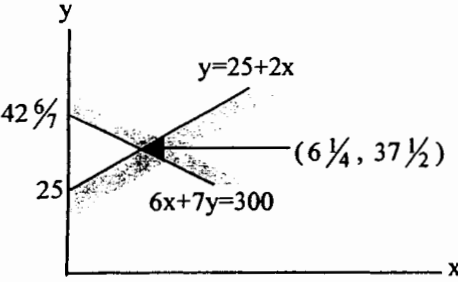
(i) $50z + x + y$	B1 $50z$ B1 $x + y$
(ii) $2z + 0.06x + 0.07y$	B1 $2z$ B1 $0.06x + 0.07y$
(iii) number of milk $\geq 2 \times$ number of plain $25z + y \geq 50z + 2x$	B1
(iv) 	B1 line 1 B1 line 2 B1 shading
(v) 	B1 line 1 B1 line 2 B1 shading B1 point
John should buy (1 box) + 6 plain and 37 milk or 5 plain and 38 milk or 4 plain and 39 milk or 3 plain and 40 milk or 2 plain and 41 milk or 1 plain and 42 milk	B1 (1 box) M1 A1

Examiner's Report

Decision and Discrete Mathematics 1 (2620)

General

Work was received from 1413 candidates at 124 centres, a very similar entry to that of the last two winters.

The majority of centres having more than one marker gave helpful details of their internal moderation procedures. Similarly, the work from most centres showed evidence of marking, but there were exceptions where there was no marking at all to be seen on the scripts.

As has been said before, some centres do need to give clearer justification of their marking for the oral.

Content

The overall standard was not as high this time as it was last winter.

As always, the best work seen originated from the candidate's own experience. Such work benefited both from the knowledge and also from the enthusiasm of the candidate.

By far the most popular topic choice was CPA, with a high proportion also on simulation, and not so many this time on LP or networks.

Off-syllabus work was again reported, where the candidate identified a TSP problem. The fact that this happened at all means that it is necessary to repeat advice issued several times previously in this respect. It is essential that candidates do not submit for assessment in 2620 tasks which could also be submitted for 2621. The problem identified must not be a 2621 problem. Offending candidates can only be credited for their 2620 work.

CPA

As in last winter's entry, the majority of the problems identified were appropriately complex and worthwhile. In some cases they were perhaps rather more complex than necessary (with 50+ activities), whilst at the other extreme there were still too many rather trivial text-book type problems. In general the CPA tasks were well done.

There were some excellent examples of resource levelling, well communicated.

As noted last time, many candidates needed to include more detailed explanation of the activities and their inter-relationships. Some precedence tables contained obvious errors which discussion and analysis might have avoided. There was usually no justification at all of activity timings, or any discussion of their possible inaccuracy.

As previously, far too many activity diagrams did not accurately reflect precedence tables. Markers too often appear not to have noticed the discrepancies.

Linear Programming

Again many candidates fell down by failing to convince the assessor that the problem they were addressing was a real one. It was heartening that there were some very good exceptions to this tendency, based on real situations. Where the problem is completely artificial candidates do not have the opportunity to score good marks for modelling, refinement or interpretation.

As before, data tended to appear out of thin air, and rarely was there any attempt to justify or consider the figures used - for example for selling prices or available resources. Too many

problems involved only two non-trivial constraints. Again some "refinements" seen in this area really were particularly thin, for example suddenly finding that more, or less, of one of the resources was available. These cases are not refinements – they are minor changes to the problem; refinements are improvements to the model.

Too many candidates again showed confusion between income and profit.

Very high marks were sometimes awarded quite inappropriately in this area.

Simulation

Most simulations seen were well rooted in real situations. They were informed by real data and often made good use of technology, although too many candidates still simulated each scenario an inadequate number of times.

Some centres had unfortunately given their candidates very prescriptive instructions in this area. This resulted in situations where every single candidate gathered the same prescribed number of data items, ran a fixed number of simulations with one server, a fixed number with two servers etc.

Networks

Few examples were seen. Most of what follows is repeated from previous reports.

Candidates need to be working with large networks in order to provide the complexity needed for earning high marks. They need to describe their data sources. Some candidates again this time tried to get away with very basic (and often completely unsubstantiated) textbook-like diagrams.

The application of algorithms needs to be clearly demonstrated using the appropriate notation. The assessor needs to be able to verify that the figures have been obtained algorithmically, and the candidate should help with this. It is not helpful to describe the algorithm in general terms – the assessor needs to see the details of its successful use to solve the particular problem.

Graphs

Again there were very few projects on graphs – not enough to make any observations or give any generalised advice.
