

Paper Reference(s)

**6664/01**

# Edexcel GCE

## Core Mathematics C2

### Gold Level G1

**Time: 1 hour 30 minutes****Materials required for examination papers**

Mathematical Formulae (Green)

**Items included with question**

Nil

Candidates may use any calculator allowed by the regulations of the Joint Council for Qualifications. Calculators must not have the facility for symbolic algebra manipulation, differentiation and integration, or have retrievable mathematical formulas stored in them.

**Instructions to Candidates**

---

Write the name of the examining body (Edexcel), your centre number, candidate number, the unit title (Core Mathematics C2), the paper reference (6664), your surname, initials and signature.

**Information for Candidates**

---

A booklet 'Mathematical Formulae and Statistical Tables' is provided.

Full marks may be obtained for answers to ALL questions.

There are 10 questions in this question paper. The total mark for this paper is 75.

**Advice to Candidates**

---

You must ensure that your answers to parts of questions are clearly labelled.

You must show sufficient working to make your methods clear to the Examiner. Answers without working may gain no credit.

**Suggested grade boundaries for this paper:**

<b>A*</b>	<b>A</b>	<b>B</b>	<b>C</b>	<b>D</b>	<b>E</b>
<b>65</b>	<b>58</b>	<b>50</b>	<b>42</b>	<b>34</b>	<b>27</b>

1. Find the first 3 terms, in ascending powers of  $x$ , of the binomial expansion of  $(3 - 2x)^5$ , giving each term in its simplest form.

(4)

January 2009

---

2. (a) Find the first 3 terms, in ascending powers of  $x$ , of the binomial expansion of

$$(3 + bx)^5$$

where  $b$  is a non-zero constant. Give each term in its simplest form.

(4)

Given that, in this expansion, the coefficient of  $x^2$  is twice the coefficient of  $x$ ,

- (b) find the value of  $b$ .

(2)

May 2011

---

3. (a) Find the first 4 terms of the expansion of  $\left(1 + \frac{x}{2}\right)^{10}$  in ascending powers of  $x$ , giving each term in its simplest form.

(4)

- (b) Use your expansion to estimate the value of  $(1.005)^{10}$ , giving your answer to 5 decimal places.

(3)

January 2008

---

4. (a) Find the positive value of  $x$  such that

$$\log_x 64 = 2.$$

(2)

- (b) Solve for  $x$

$$\log_2 (11 - 6x) = 2 \log_2 (x - 1) + 3.$$

(6)

January 2010

---

5. A geometric series has first term 5 and common ratio  $\frac{4}{5}$ .

Calculate

(a) the 20th term of the series, to 3 decimal places, (2)

(b) the sum to infinity of the series. (2)

Given that the sum to  $k$  terms of the series is greater than 24.95,

(c) show that  $k > \frac{\log 0.002}{\log 0.8}$ , (4)

(d) find the smallest possible value of  $k$ . (1)

**June 2008**

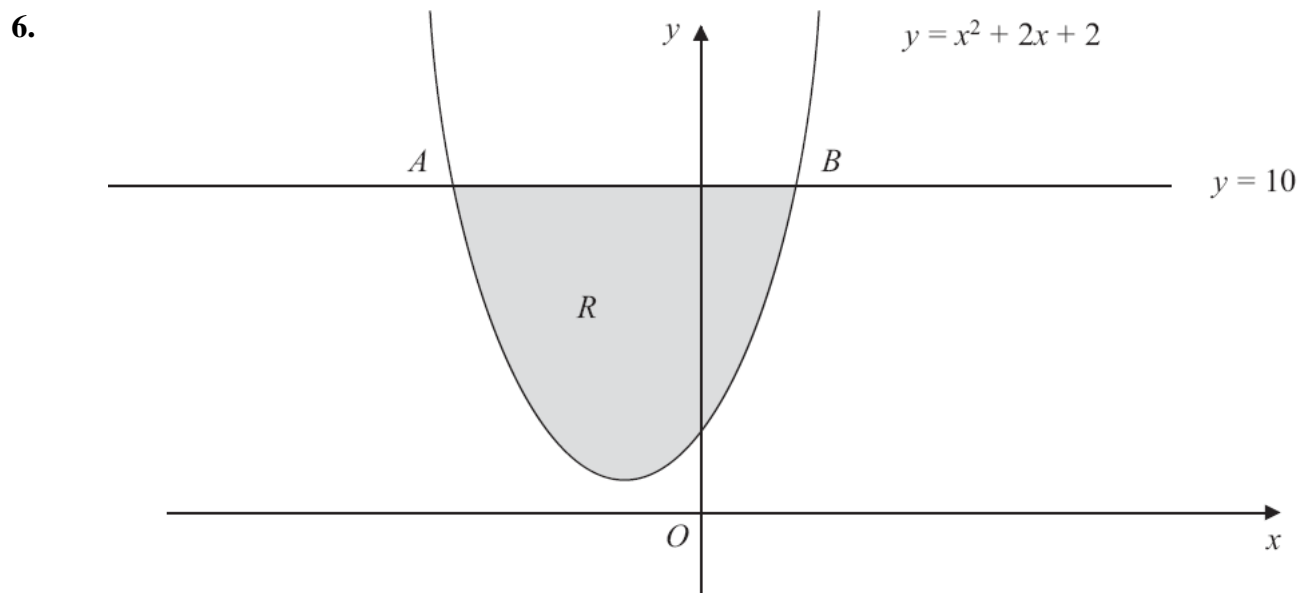

**Figure 1**

The line with equation  $y = 10$  cuts the curve with equation  $y = x^2 + 2x + 2$  at the points  $A$  and  $B$  as shown in Figure 1. The figure is not drawn to scale.

(a) Find by calculation the  $x$ -coordinate of  $A$  and the  $x$ -coordinate of  $B$ . (2)

The shaded region  $R$  is bounded by the line with equation  $y = 10$  and the curve as shown in Figure 1.

(b) Use calculus to find the exact area of  $R$ . (7)

**May 2013 (R)**

7.

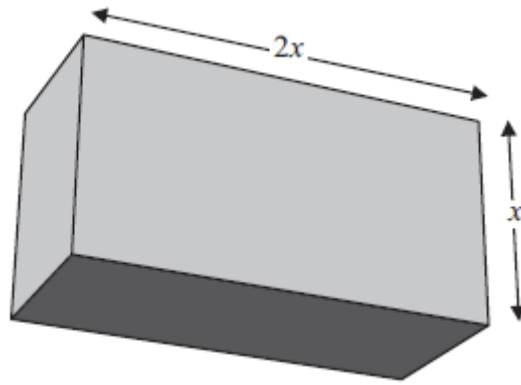
**Figure 2**

A cuboid has a rectangular cross-section where the length of the rectangle is equal to twice its width,  $x$  cm, as shown in Figure 2.

The volume of the cuboid is 81 cubic centimetres.

(a) Show that the total length,  $L$  cm, of the twelve edges of the cuboid is given by

$$L = 12x + \frac{162}{x^2}. \quad (3)$$

(b) Use calculus to find the minimum value of  $L$ . (6)

(c) Justify, by further differentiation, that the value of  $L$  that you have found is a minimum. (2)

**May 2011**

---

8. Solve, for  $0 \leq x < 360^\circ$ ,

(a)  $\sin(x - 20^\circ) = \frac{1}{\sqrt{2}}$ , (4)

(b)  $\cos 3x = -\frac{1}{2}$ . (6)

**June 2008**

---

9. The circle  $C$  has centre  $A(2,1)$  and passes through the point  $B(10, 7)$  .

(a) Find an equation for  $C$ .

(4)

The line  $l_1$  is the tangent to  $C$  at the point  $B$ .

(b) Find an equation for  $l_1$ .

(4)

The line  $l_2$  is parallel to  $l_1$  and passes through the mid-point of  $AB$ .

Given that  $l_2$  intersects  $C$  at the points  $P$  and  $Q$ ,

(c) find the length of  $PQ$ , giving your answer in its simplest surd form.

(3)

June 2010

---

**TOTAL FOR PAPER: 75 MARKS**

**END**

Question Number	Scheme	Marks
1.	$(3 - 2x)^5 = 243, \dots + 5 \times (3)^4(-2x) = -810x \dots$ $+ \frac{5 \times 4}{2} (3)^3(-2x)^2 = +1080x^2$	B1, B1 M1 A1 [4]
2. (a)  (b)	$\{(3 + bx)^5\} = (3)^5 + {}^5C_1(3)^4(bx) + {}^5C_2(3)^3(bx)^2 + \dots$ $= 243 + 405bx + 270b^2x^2 + \dots$ $\{2(\text{coeff } x) = \text{coeff } x^2\} \Rightarrow 2(405b) = 270b^2$ $\text{So, } \left\{ b = \frac{810}{270} \Rightarrow \right\} b = 3$	B1 B1 M1 A1 (4) M1 A1 (2) [6]
3. (a)  (b)	$\left(1 + \frac{1}{2}x\right)^{10} = 1 + \binom{10}{1}\left(\frac{1}{2}x\right) + \binom{10}{2}\left(\frac{1}{2}x\right)^2 + \binom{10}{3}\left(\frac{1}{2}x\right)^3$ $= 1 + 5x; + \frac{45}{4}(\text{or } 11.25)x^2 + 15x^3$ $(1 + \frac{1}{2} \times 0.01)^{10} = 1 + 5(0.01) + \left(\frac{45}{4} \text{ or } 11.25\right)(0.01)^2 + 15(0.01)^3$ $= 1 + 0.05 + 0.001125 + 0.000015$ $= 1.05114 \text{ cao}$	M1 A1 A1; A1 (4) M1 A1√ A1 (3) [7]
4. (a)  (b)	$\log_x 64 = 2 \Rightarrow 64 = x^2$ $\text{So } x = 8$ $\log_2(11 - 6x) = \log_2(x - 1)^2 + 3$ $\log_2 \left[ \frac{11 - 6x}{(x - 1)^2} \right] = 3$ $\frac{11 - 6x}{(x - 1)^2} = 2^3$ $\{11 - 6x = 8(x^2 - 2x + 1)\} \text{ and so } 0 = 8x^2 - 10x - 3$ $0 = (4x + 1)(2x - 3) \Rightarrow x = \dots$ $x = \frac{3}{2}, \left[ -\frac{1}{4} \right]$	M1 A1 (2) M1 M1 M1 A1 dM1 A1 (6) [8]

Question Number	Scheme	Marks
<p>5. (a)</p> <p>(b)</p> <p>(c)</p> <p>(d)</p>	$T_{20} = 5 \times \left(\frac{4}{5}\right)^{19} = 0.072$ $S_{\infty} = \frac{5}{1-0.8} = 25$ $\frac{5(1-0.8^k)}{1-0.8} > 24.95$ $1-0.8^k > 0.998 \text{ or equivalent}$ $k \log 0.8 < \log 0.002 \text{ or } k > \log_{0.8} 0.002$ $k > \frac{\log 0.002}{\log 0.8}$ $k = 28$	<p>M1 A1</p> <p>(2)</p> <p>M1 A1</p> <p>(2)</p> <p>M1</p> <p>A1</p> <p>M1</p> <p>A1 cso</p> <p>(4)</p> <p>B1</p> <p>(1)</p> <p>[9]</p>
<p>6. (a)</p> <p>(b)</p>	$x^2 + 2x + 2 = 10 \Rightarrow x^2 + 2x - 8 = 0 \text{ ( so } (x+4)(x-2) = 0 \text{ ) } \Rightarrow x = \dots\dots$ $x = -4, 2$ $\int (x^2 + 2x + 2) dx = \frac{x^3}{3} + \frac{2x^2}{2} + 2x (+C)$ $\left[ \frac{x^3}{3} + \frac{2x^2}{2} + 2x \right]_{-4}^{2} = \left( \frac{8}{3} + \frac{8}{2} + 4 \right) - \left( -\frac{64}{3} + \frac{32}{2} - 8 \right) \quad (= 24)$ <p>Rectangle: <math>10 \times (2 - -4) = 60</math></p> $R = "60" - "24"$ $= 36$	<p>M1</p> <p>A1</p> <p>(2)</p> <p>M1 A1</p> <p>A1</p> <p>M1</p> <p>B1 cao</p> <p>M1</p> <p>A1</p> <p>(7)</p> <p>[9]</p>

Question Number	Scheme	Marks
<p>7. (a)</p> <p>(b)</p> <p>(c)</p>	$\{V = \} \quad 2x^2y = 81$ $\{L = 2(2x + x + 2x + x) + 4y \Rightarrow L = 12x + 4y\}$ $y = \frac{81}{2x^2} \Rightarrow L = 12x + 4\left(\frac{81}{2x^2}\right)$ $\text{So, } L = 12x + \frac{162}{x^2} \quad \text{AG}$ $\frac{dL}{dx} = 12 - \frac{324}{x^3} \quad \{= 12 - 324x^{-3}\}$ $\left\{\frac{dL}{dx} = \right\} 12 - \frac{324}{x^3} = 0 \Rightarrow x^3 = \frac{324}{12}; = 27 \Rightarrow x = 3$ $\{x = 3,\} \quad L = 12(3) + \frac{162}{3^2} = 54 \text{ (cm)}$ $\{\text{For } x = 3\}, \quad \frac{d^2L}{dx^2} = \frac{972}{x^4} > 0 \Rightarrow \text{Minimum}$	<p>B1 oe</p> <p>M1</p> <p>A1 cso</p> <p>(3)</p> <p>M1</p> <p>A1 aef</p> <p>M1;</p> <p>A1 cso</p> <p>ddM1</p> <p>A1 cao</p> <p>(6)</p> <p>M1 A1</p> <p>(2)</p> <p>[11]</p>
<p>8. (a)</p> <p>(b)</p>	<p>45 <math>(\alpha)</math></p> <p>180 – <math>\alpha</math> ,                      Add 20 (for at least one angle)</p> <p>65 155</p> <p>120 or 240 <math>(\beta)</math>:</p> <p>360 – <math>\beta</math> , 360 + <math>\beta</math></p> <p>Dividing by 3 (for at least one angle)</p> <p>40 80 160 200 280 320</p>	<p>B1</p> <p>M1 M1</p> <p>A1</p> <p>(4)</p> <p>B1</p> <p>M1 M1</p> <p>M1</p> <p>A1 A1</p> <p>(6)</p> <p>[10]</p>



Question Number	Scheme	Marks
<p>9. (a)</p> <p>(b)</p> <p>(c)</p>	$(10-2)^2 + (7-1)^2$ or $\sqrt{(10-2)^2 + (7-1)^2}$	M1 A1
	$(x \pm 2)^2 + (y \pm 1)^2 = k$ ( $k$ a positive <u>value</u> )	M1
	$(x-2)^2 + (y-1)^2 = 100$	A1
		(4)
	(Gradient of radius $\Rightarrow \frac{7-1}{10-2} = \frac{6}{8}$ (o.e.)	B1
	Gradient of tangent $= \frac{-4}{3}$	M1
	$y-7 = m(x-10)$	M1
	$y-7 = \frac{-4}{3}(x-10)$ (o.e.)	A1ft
		(4)
	$\sqrt{r^2 - \left(\frac{r}{2}\right)^2}$	M1
$= \sqrt{10^2 - 5^2}$ (o.e.)	A1	
$PQ (= 2\sqrt{75}) = 10\sqrt{3}$	A1	
		(3)
		<b>[8]</b>

## Examiner reports

### Question 1

This binomial expansion was answered well with a majority of the candidates scoring full marks. The most common errors involved signs and slips in evaluating the powers and binomial coefficients. A number of weaker candidates changed the question and instead expanded  $(1 \pm 2x)^5$ . This gained no credit.

### Question 2

The most successful strategy seen in part (a) was for candidates to use the formula for  $(a + b)^n$  to expand  $(3 + bx)^5$  to give  $(3)^5 + {}^5C_1(3)^4(bx) + {}^5C_2(3)^3(bx)^2 + \dots$ . A few candidates used Pascal's triangle to correctly derive their binomial coefficients, whilst a few other candidates used  $n = 3$  in their binomial expansion resulting in incorrect binomial coefficients. A significant number of candidates made a bracketing error to give  $270bx^2$  as their term in  $x^2$ . Some candidates did not consider powers of 3 in and wrote  $1 + 5bx + 10b^2x^2 + \dots$ , whilst a few other candidates did not include any  $x$ 's in their binomial expansion.

A minority of candidates wrote  $(3 + bx)^5$  in the form  $k\left(1 + \frac{bx}{3}\right)^5$ , and proceeded to apply the  $(1 + x)^n$  form of the binomial expansion. Those candidates who used  $k = 3^5$ , usually went on to gain full marks. A significant number of candidates either used  $k = 1$  or  $k = 3$  to achieve incorrect answers of either  $1 + \frac{5b}{3}x + \frac{10}{9}b^2x^2 + \dots$  or  $3 + 5bx + \frac{10}{3}b^2x^2 + \dots$  respectively and gained only 1 mark for this part.

Part (b) was also fairly well attempted when compared with previous years but there were still a significant number of candidates who did not understand that the coefficient does not include the  $x$  or  $x^2$  part of a term. These candidates were usually unable to form an equation in  $b$  alone. A common error was for candidates to form an equation in  $b$  by multiplying the coefficient of  $x^2$  by 2 instead of the coefficient of  $x$ . A few candidates formed an equation in  $b$  using the first and the second terms rather than the second and third terms.

A handful of candidates ignored their binomial expansion and gave the answer 2, using their flawed logic of "twice 2" being equal to "2 squared". Other less common errors included either giving an answer of  $b = \frac{1}{3}$  following on from  $810 = 270b$  or  $b = 1.5$  following on from not multiplying either coefficient by 2.

### Question 3

It was pleasing to see that most candidates could make some headway in part (a) and many candidates gained full marks. The usual errors of omitting brackets around  $\frac{x}{2}$ , and using

$\left(\frac{10}{r}\right)$  for  $\binom{10}{r}$ , were seen, but not as frequently as on previous occasions. It was also

common to see the coefficients of powers of  $x$  not reduced to their simplest form. Solutions to part (b) were variable, with many candidates not able to find the appropriate value of  $x$  to use;

frequently 0.005 was substituted into a correct, or near correct expansion expression found in (a). Just writing the answer down, with no working at all, gained no marks.

#### Question 4

Part (a) Generally, both marks were scored easily with most candidates writing  $x^2 = 64$  and  $x = 8$ . Some included the  $-8$  value as well, indicating that they were not always reading the finer details of the questions. However, quite a few attempts proceeded to  $2^x = 64$  leading to the most common incorrect answer seen of  $x = 6$ . A small group squared 64. Very few students attempted to change base in this part of the question.

Part (b) Most candidates scored the first M mark by expressing  $2 \log_2(x - 1)$  as  $\log_2(x - 1)^2$  but many then failed to gain any further marks. It was not uncommon for scripts to proceed from  $\log_2(11 - 6x) = \log_2(x - 1)^2 + 3$  to  $(11 - 6x) = (x - 1)^2 + 3$ , resulting in the loss of all further available marks.

A significant number of candidates seem to be completely confused over the basic log rules. Working such as  $\log_2(11 - 6x) = \log_2 11 / \log_2 6x$  following  $\log_2(11 - 6x) = \log_2 11 - \log_2 6x$  was seen on many scripts. Most candidates who were able to achieve the correct quadratic equation were able to solve it successfully, generally by factorisation, although some chose to apply the quadratic formula. There were a good number of completely correct solutions but the  $x = -1/4$  was invariably left in, with very few candidates appreciating the need to reject it. Fortunately they were not penalised this time.

#### Question 5

Parts (a) and (b) of this question were very well done and the majority of candidates gained full marks here. A few, however, found the sum of 20 terms in part (a) rather than the 20th term.

Only the very best candidates achieved full marks in part (c). The main difficulty was in dealing correctly with the inequality throughout the working. Often there were mistakes in manipulation and the division by  $\log 0.8$  (a negative value) rarely resulted in the required 'reversal' of the inequality sign. Another common mistake was to say that  $5 \times 0.8^k = 4^k$ . Despite these problems, many candidates were still able to score two or three marks out of the available four.

A surprising number of candidates made no attempt at part (d) and clearly did not realise they simply had to evaluate the expression in (c). Many failed to appreciate that  $k$  had to be an integer.

#### Question 6

Almost all candidates correctly obtained the values  $-4$  and  $2$  in part (a).

In part (b) most candidates knew they had to integrate to find the area, and most did so correctly, with only a few differentiating and only a few mistakes in the integration. They generally used the limits correctly, though a surprising number split from  $-4$  to  $0$  and from  $0$  to  $2$ . It was quite common to leave the final answer as  $24$ . Arithmetic with fractions was invariably well executed. Those who found the rectangle area separately usually did this correctly. Many candidates subtracted the functions before integrating and this often led to the predictable errors of incorrect subtraction, or of obtaining a negative area after subtraction the wrong way round. Some did realise that the area must be positive, but the reason for the sign change was not always explained.

**Question 7**

In part (a), responses either scored no marks, one mark or all three marks. Those candidates who scored no marks often failed to recognise the significance of the volume. Some tried to calculate surface area, while others failed to introduce another variable for the height of the cuboid and usually wrote down  $2x^3 = 81$ . It was obvious that many candidates were trying (often unsuccessfully) to work back from the given result. Quite often  $\frac{81}{2x^2}$  was simplified to  $\frac{162}{x^2}$ . A few candidates gave up at this stage and failed to attempt the remainder of the question.

In part (b), many candidates were able to gain the first 4 marks through accurate differentiation and algebra. Mistakes were occasionally made in the differentiation of  $162x^{-2}$ ; in manipulating  $12 - \frac{324}{x^3} = 0$  to give  $x = \frac{1}{3}$ ; and in solving  $x^3 = 27$  to give  $x = \pm 3$ . The last two marks of this part were too frequently lost as candidates neglected to find the minimum value of  $L$ . This is a recurring problem and suggests that some candidates may lack an understanding of what 'minimum' (or maximum) refers to; in this case  $L$ , and not  $x$ . This is a common misconception but does suggest that while some candidates have mastered the techniques of differentiation they may lack a deeper understanding of what they are actually finding.

In part (c), a significant number of candidates were able to successfully find the second derivative and usually considered the sign and made an acceptable conclusion. Most candidates found the value of the second derivative when  $x = 3$ , although a few candidates left  $\frac{d^2L}{dx^2}$  as  $\frac{972}{x^4}$ , without considering its sign or giving a conclusion. Occasionally the second derivative was equated to zero, but there were very few candidates offering non-calculus solutions.

**Question 8**

The most able candidates completed this question with little difficulty, sometimes using sketches of the functions to identify the possible solutions. Generally speaking, however, graphical approaches were not particularly successful.

In part (a), most candidates were able to obtain  $45^\circ$  and went onto get  $x = 65^\circ$  but it was disappointing to see  $115^\circ$  so frequently as the second answer ( $180 - 65$ ). A surprising number of candidates subtracted 20 rather than adding, giving the answers  $25^\circ$  and  $115^\circ$ . A number of candidates gave their first angle in radians and then proceeded to get further solutions by mixing degrees with radians. It was encouraging that few candidates thought  $\sin(x - 20)$  was equivalent to  $\sin x - \sin 20$ .

In part (b), the majority of candidates were able to obtain one or two correct solutions, but sometimes 'correct' answers followed incorrect working. Those with a good understanding of trigonometric functions produced very concise solutions, adding  $360^\circ$  and  $720^\circ$  to their values of  $3x$ , then dividing all values by 3. Weaker candidates often gave solutions with no clear indication of method, which were very difficult for examiners to follow.

As in part (a), disastrous initial steps such as  $\cos 3x = -\frac{1}{2} \Rightarrow \cos x = -\frac{1}{6}$  were rare.

**Question 9**

In part (a), most candidates were able to write down an expression for the radius of the circle (or the square of the radius). Most were also familiar with the form of the equation of a circle, although some weaker candidates gave equations of straight lines. Sometimes radius was confused with diameter, sometimes (10, 7) was used as the centre instead of (2, 1) and sometimes the equation of the circle was given as  $(x - 2)^2 + (y - 1)^2 = 10$  instead of  $(x - 2)^2 + (y - 1)^2 = 10^2$ .

Many candidates knew the method for finding the equation of the tangent at (10, 7). Typical mistakes here were to invert the gradient of the radius  $AB$ , to find a line parallel to the radius and to find a line through the centre of the circle.

Part (c), for which there was a very concise method, proved difficult even for able candidates. Those who drew a simple sketch were sometimes able to see that the length of the chord could easily be found by using Pythagoras' Theorem, but a more popular (and very lengthy) approach was to find the equation of the chord, to find the points of intersection between the chord and the circle, and then to find the distance between these points of intersection. This produced a great deal of complicated algebra and wasted much time. Mistakes usually limited candidates to at most 1 mark out of 3, but a few produced impressively accurate algebra. Weaker candidates often made little progress with this question.

## Statistics for C2 Practice Paper Gold Level G1

Qu	Max score	Modal score	Mean %	Mean score for students achieving grade:							
				ALL	A*	A	B	C	D	E	U
1	4		76	3.05		3.70	3.26	2.91	2.58	2.21	1.43
2	6		74	4.46	5.82	5.70	5.22	4.66	4.04	3.34	2.00
3	7		66	4.62		6.35	4.91	4.39	3.51	2.90	1.66
4	8		57	4.59		6.73	4.83	3.73	2.47	2.10	1.24
5	9		61	5.50		7.47	6.37	5.43	4.56	3.87	2.31
6	9		86	7.74	8.95	8.58	8.06	7.60	6.89	6.32	3.59
7	11		53	5.87	10.38	9.49	7.44	5.58	3.88	2.60	0.95
8	10		55	5.53		8.62	6.73	5.34	4.03	2.72	1.22
9	11		54	5.92	10.11	8.69	7.36	6.32	4.92	3.31	1.16
	<b>75</b>		<b>63</b>	<b>47.28</b>		<b>65.33</b>	<b>54.18</b>	<b>45.96</b>	<b>36.88</b>	<b>29.37</b>	<b>15.56</b>