

Solutionbank M2

Edexcel AS and A Level Modular Mathematics

Exercise A, Question 1

Question:

Find the sum of the moments about P of the forces shown.

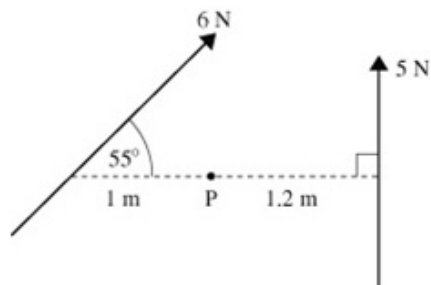

Solution:

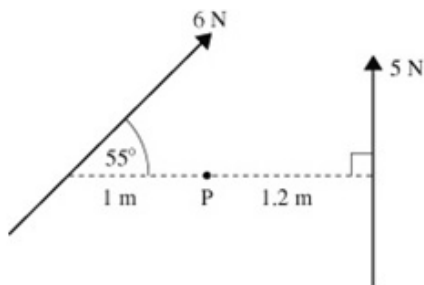

$$\odot \quad 1 \times 6 \times \sin 55 = 4.91\dots$$

$$\odot \quad 1.2 \times 5 = 6$$

$$\Rightarrow \quad 6 - 4.91 = 1.09 \text{ Nm anticlockwise}$$

Solutionbank M2

Edexcel AS and A Level Modular Mathematics

Exercise A, Question 2

Question:

Find the sum of the moments about P of the forces shown.

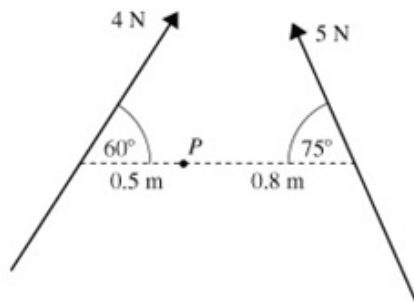

Solution:

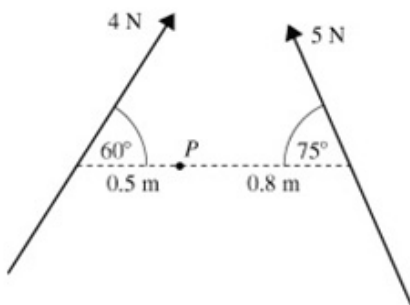

$$\begin{aligned} \odot & 0.5 \times 4 \times \sin 60 = 1.73\dots \\ \odot & 0.8 \times 5 \times \sin 75 = 3.86\dots \\ \Rightarrow & 3.86 - 1.73 \\ & = 2.13 \text{ Nm anticlockwise} \end{aligned}$$

Solutionbank M2

Edexcel AS and A Level Modular Mathematics

Exercise A, Question 3

Question:

Find the sum of the moments about P of the forces shown.

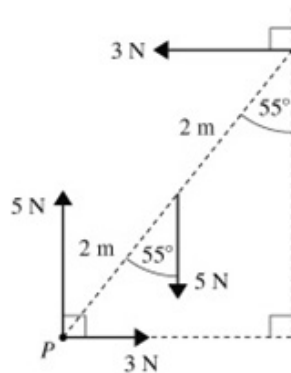

Solution:

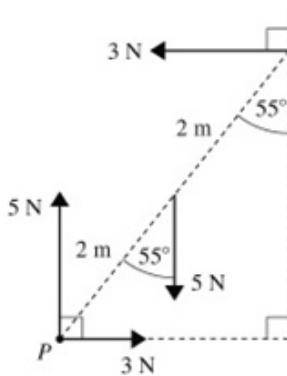

$$\begin{aligned} \curvearrowright & 5 \times 2 \times \sin 55 = 8.19\dots \\ \curvearrowright & 3 \times 4 \times \cos 55 = 6.88\dots \\ \Rightarrow & 8.19 - 6.88 \\ & = 1.31 \text{ Nm clockwise} \end{aligned}$$

Solutionbank M2

Edexcel AS and A Level Modular Mathematics

Exercise A, Question 4

Question:

Find the sum of the moments about P of the forces shown.

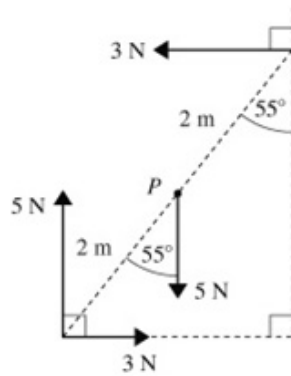

Solution:

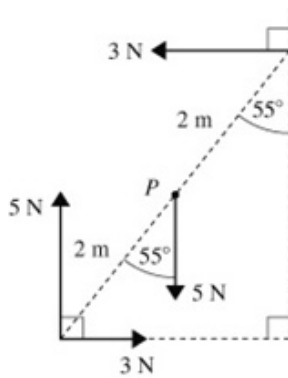

$$\begin{aligned} \odot & 5 \times 2 \times \sin 55^\circ = 8.19\dots \\ \odot & 3 \times 2 \times \cos 55^\circ + 3 \times 2 \times \cos 55^\circ \\ & = 6.88\dots \\ \Rightarrow & 1.31 \text{ Nm clockwise} \end{aligned}$$

Solutionbank M2

Edexcel AS and A Level Modular Mathematics

Exercise A, Question 5

Question:

Find the sum of the moments about P of the forces shown.

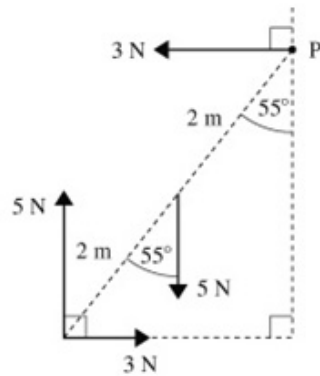

Solution:

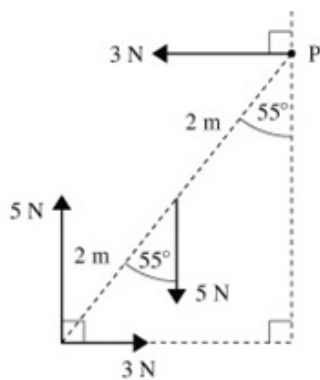

$$\begin{aligned} \circlearrowleft & 3 \times 4 \times \cos 55^\circ + 5 \times 2 \times \sin 55^\circ \\ & = 15.07\dots \\ \circlearrowright & 5 \times 4 \times \sin 55^\circ = 16.38\dots \\ \Rightarrow & 1.31 \text{ Nm anticlockwise} \end{aligned}$$

Solutionbank M2

Edexcel AS and A Level Modular Mathematics

Exercise A, Question 6

Question:

Find the sum of the moments about P of the forces shown.

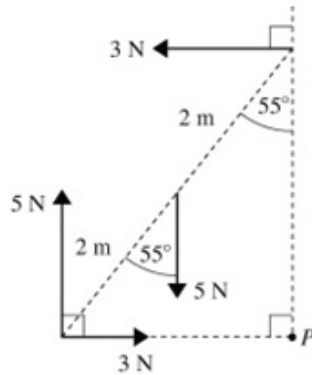

Solution:

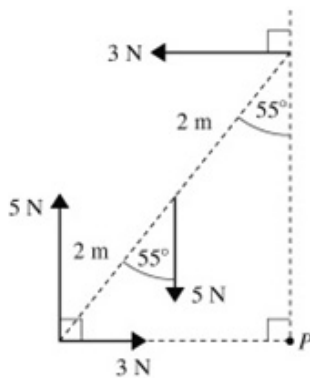

$$\begin{aligned} \odot & 5 \times 4 \times \sin 55^\circ = 16.38\dots \\ \odot & 3 \times 4 \times \cos 55^\circ + 5 \times 2 \times \sin 55^\circ \\ & = 15.07\dots \\ \Rightarrow & 1.31 \text{ Nm clockwise} \end{aligned}$$

Solutionbank M2

Edexcel AS and A Level Modular Mathematics

Exercise A, Question 7

Question:

Find the sum of the moments about P of the forces shown.

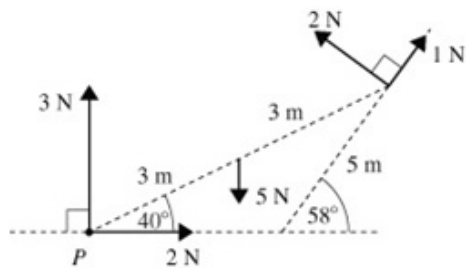

Solution:

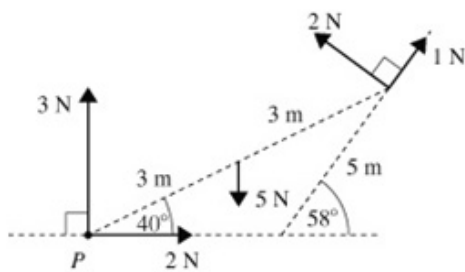

$$\begin{aligned} \odot & 5 \times 3 \times \cos 40^\circ = 11.49\dots \\ \odot & 2 \times 5 \times \sin 71^\circ + 1 \times 5 \times \sin 19^\circ \\ & = 13.29\dots \\ \Rightarrow & 1.81 \text{ Nm anticlockwise} \end{aligned}$$

Solutionbank M2

Edexcel AS and A Level Modular Mathematics

Exercise A, Question 8

Question:

Find the sum of the moments about P of the forces shown.

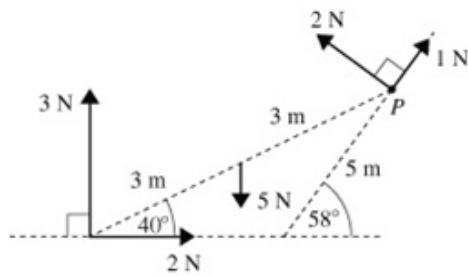

Solution:

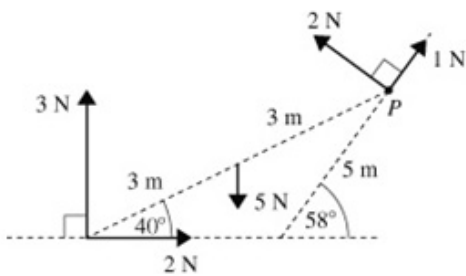

$$\begin{aligned} \odot & 3 \times 6 \times \cos 40^\circ = 13.7\dots \\ \odot & 5 \times 3 \times \cos 40^\circ + 2 \times 6 \times \sin 40^\circ \\ & = 19.2\dots \\ \Rightarrow & 5.42 \text{ Nm anticlockwise} \end{aligned}$$

Solutionbank M2

Edexcel AS and A Level Modular Mathematics

Exercise A, Question 9

Question:

Find the sum of the moments about P of the forces shown.

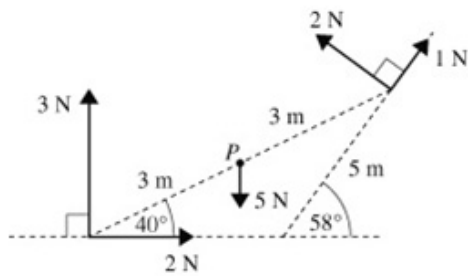

Solution:

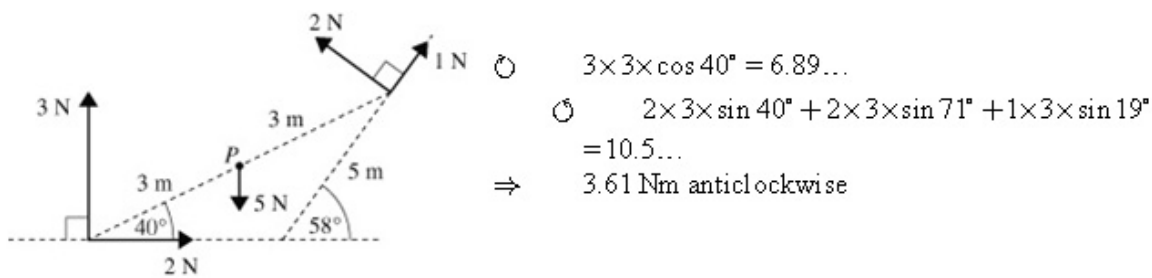

Solutionbank M2

Edexcel AS and A Level Modular Mathematics

Exercise A, Question 10

Question:

Find the sum of the moments about P of the forces shown.

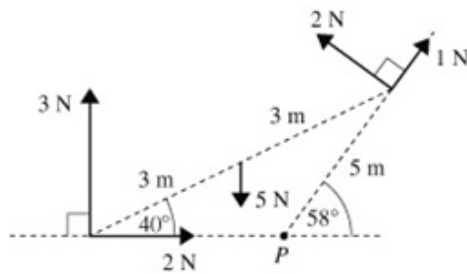

Solution:

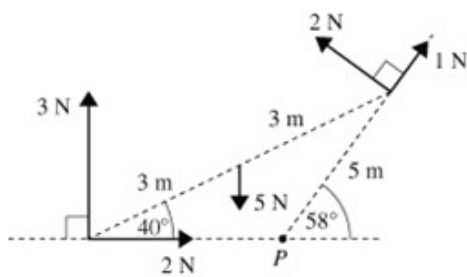

$$\begin{aligned} & \odot \quad 3 \times (6 \times \cos 40^\circ - 4.5 \times \cos 59^\circ) = 6.83\dots \\ & \ominus \quad 2 \times 4.5 + 5 \times (3 \times \cos 40^\circ - 4.5 \times \cos 59^\circ) \\ & \quad = 8.90\dots \\ & \Rightarrow \quad 2.07 \text{ Nm anticlockwise} \end{aligned}$$

NB Since $3 \times \cos 40^\circ - 4.5 \times \cos 59^\circ = -0.019\dots$
 We can deduce that the 5 N force has a clockwise moment about P . However, this does not mean that the working is invalid – the negative value compensates for the sense of the rotation.

Solutionbank M2

Edexcel AS and A Level Modular Mathematics

Exercise B, Question 1

Question:

Whenever a numerical value of g is required, take $g = 9.8 \text{ m s}^{-2}$.

Each of the following diagrams shows a uniform beam AB of length 4 m and mass 6 kg.

The beam is freely hinged at A and resting horizontally in equilibrium. In each case find

- the magnitude of the force T ,
- the magnitude and direction of the reaction at A .

a

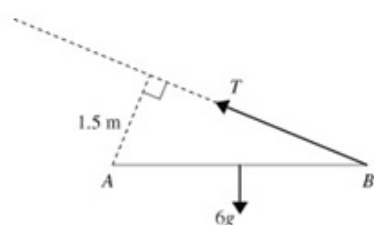

b

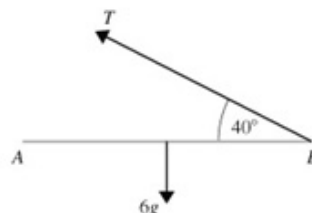

c

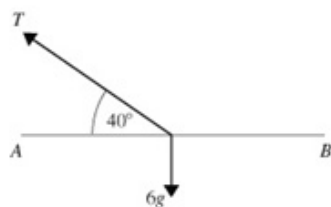

d

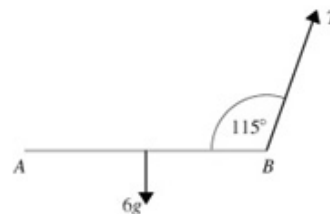

Solution:

a

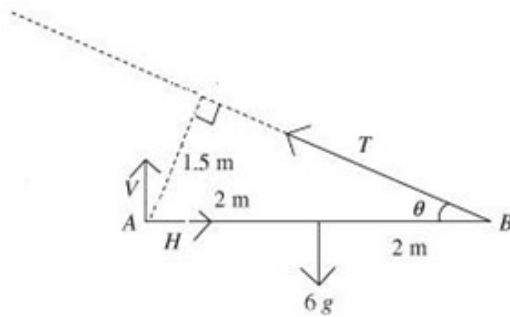

Using moments:

$$\odot A: 6g \times 2 = T \times 1.5$$

$$T = 8g = 78.4 \text{ N}$$

$$R(\uparrow) V + T \sin \theta = 6g$$

$$V = 6g - T \times \frac{1.5}{4} = 29.4 \text{ N}$$

$$\leftrightarrow H = T \cos \theta = T \times \frac{\sqrt{64-9}}{8} = 72.7 \text{ N}$$

Using Pythagoras:

Magnitude of the force at A

$$= \sqrt{29.4^2 + 72.7^2} = 78.4 \text{ N}$$

The force acts at $\tan^{-1} \frac{29.4}{72.7} = 22^\circ$ above AB.

b

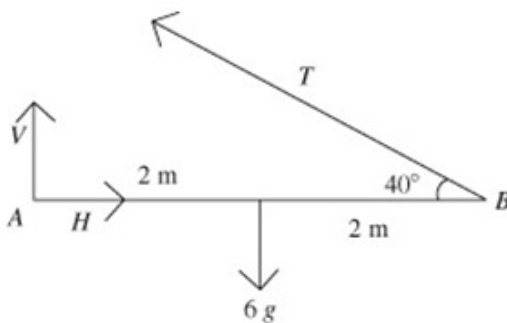

Using moments:

$$\odot A: 6g \times 2 = T \times 4 \sin 40^\circ$$

$$T = 45.7 \text{ N}$$

$$R(\uparrow) V + T \sin 40^\circ = 6g$$

$$V = 6g - T \sin 40^\circ = 29.4 \text{ N}$$

$$R(\rightarrow) H = T \cos 40^\circ = 35.0 \text{ N}$$

Using Pythagoras:

Magnitude of the force at A

$$= \sqrt{29.4^2 + 35.0^2} = 45.7 \text{ N}$$

The force acts at $\tan^{-1} \frac{29.4}{35.0} = 40^\circ$ above AB.

c

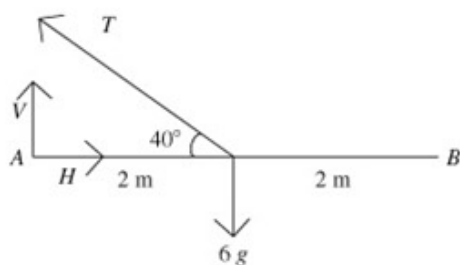

Using moments:

$$\odot A: 6g \times 2 = T \times 2 \sin 40^\circ$$

$$T = 91.5 \text{ N}$$

$$R(\uparrow) V + T \sin 40^\circ = 6g$$

$$V = 6g - T \sin 40^\circ = 0 \text{ N}$$

$$R(\rightarrow) H = T \cos 40^\circ = 70.1 \text{ N}$$

Magnitude of the force at A = 70.1 N.

The force acts parallel to AB.

d



Using moments:

$$\odot A: 6g \times 2 = T \sin 65^\circ \times 4$$

© Pearson Education Ltd 2009

Solutionbank M2

Edexcel AS and A Level Modular Mathematics

Exercise B, Question 2

Question:

Each of the following diagrams shows a uniform rod XY of mass 4 kg and length 5 m.

The rod is freely hinged to a vertical wall at X . The rod rests in equilibrium at an angle to the horizontal. Find the magnitude of the force F in each case.

a

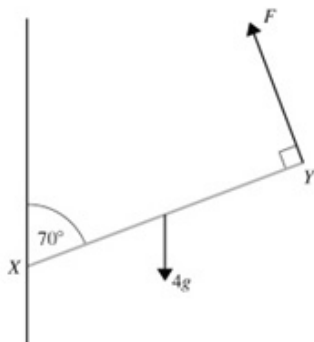

b

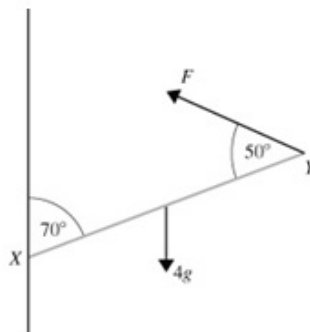

c

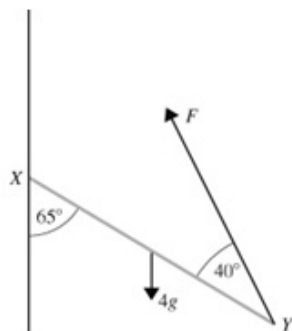

d

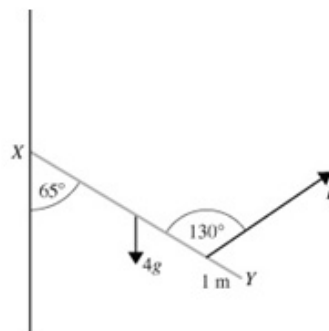

Solution:

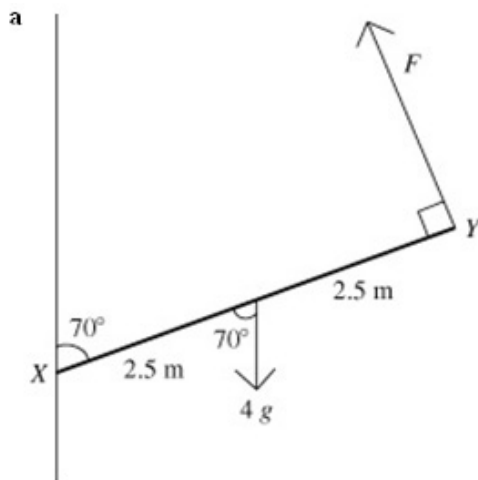

$$M(X) \quad 2.5 \times 4g \times \sin 70^\circ = 5 \times F$$

$$F = \frac{10g \times \sin 70^\circ}{5} = 18.4 \text{ N}$$

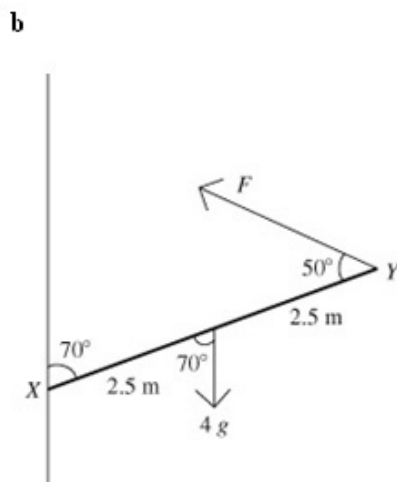

$$M(X) \quad 2.5 \times 4g \times \sin 70^\circ = 5 \times F \times \sin 50^\circ$$

$$F = \frac{10g \times \sin 70^\circ}{5 \times \sin 50^\circ} = 24.0 \text{ N}$$

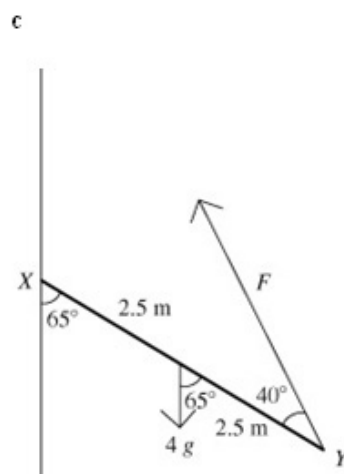

$$M(X) \quad 2.5 \times 4g \times \sin 65^\circ = 5 \times F \times \sin 40^\circ$$

$$F = \frac{10g \times \sin 65^\circ}{5 \times \sin 40^\circ} = 27.6 \text{ N}$$

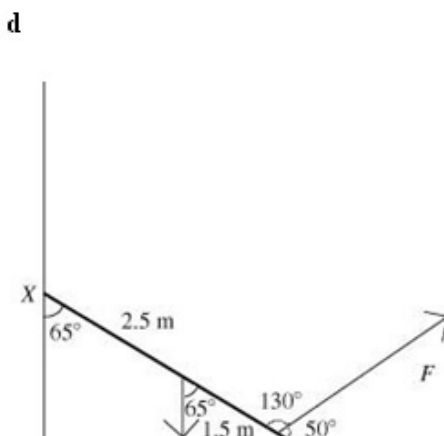

$$M(X) \quad 2.5 \times 4g \times \sin 65^\circ = 4 \times F \times \sin 50^\circ$$

$$F = \frac{10g \times \sin 65^\circ}{4 \times \sin 50^\circ} = 29.0 \text{ N}$$

© Pearson Education Ltd 2009

Solutionbank M2

Edexcel AS and A Level Modular Mathematics

Exercise B, Question 3

Question:

A uniform rod AB of length $2a$ m and mass m kg is smoothly hinged at A . It is maintained in equilibrium by a horizontal force of magnitude P acting at B . The rod is inclined at 30° to the horizontal with B below A .

- a Show that $P = \frac{\sqrt{3}}{2}mg$.
- b Find the magnitude and direction of the reaction at the hinge.

Solution:

a

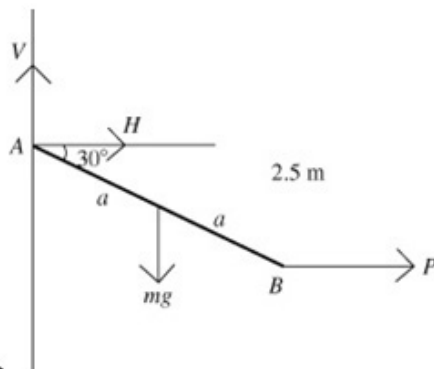

$$\begin{aligned} M(A) \quad mg \times a \cos 30^\circ &= P \times 2a \times \sin 30^\circ \\ P &= \frac{mga \cos 30^\circ}{2a \sin 30^\circ} \\ &= \frac{mga \frac{\sqrt{3}}{2}}{2a \frac{1}{2}} \\ &= \frac{\sqrt{3}}{2}mg \\ &\text{as required.} \end{aligned}$$

b

$$\begin{aligned} R(\uparrow) \quad V &= mg \\ R(\rightarrow) \quad H + P &= 0, \quad H = -\frac{\sqrt{3}}{2}mg \\ \Rightarrow \text{The reaction at the hinge has magnitude} &= mg \sqrt{1^2 + \left(\frac{\sqrt{3}}{2}\right)^2} = mg \sqrt{\frac{7}{4}} = \frac{\sqrt{7}}{2}mg \\ \text{and acts at } \tan^{-1} \frac{1}{\left(\frac{\sqrt{3}}{2}\right)} &= 49.1^\circ \text{ to the vertical (away from } AB). \end{aligned}$$

Solutionbank M2

Edexcel AS and A Level Modular Mathematics

Exercise B, Question 4

Question:

A uniform beam AB of mass 10 kg and length 3 m is attached to a vertical wall by means of a smooth hinge at A . The beam is maintained in the horizontal position by means of a light inextensible string, one end of which is attached to the beam at B and the other end of which is attached to the wall at a point 2 m vertically above A .

a Find the tension in the string.

A particle of mass $M\text{ kg}$ is now attached to the beam at B .

b Given that the tension in the string is now double its original value, find the value of M .

Solution:

a

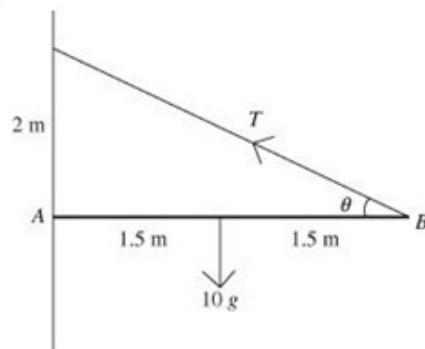

$$\text{So } T = 15g \times \frac{\sqrt{13}}{6} = 88.3\text{ N}$$

b

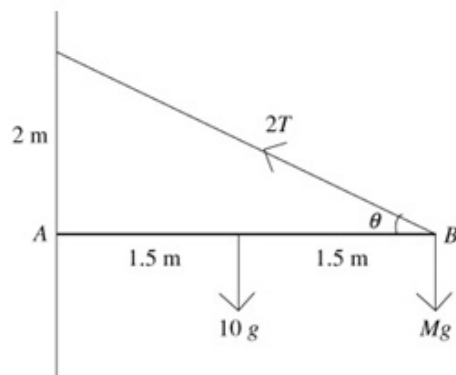

$$\begin{aligned} M(A) \quad 10g \times 1.5 + Mg \times 3 &= 2T \sin \theta \times 3 = 2 \times 15g \\ 3Mg &= 15g, \\ M &= 5 \end{aligned}$$

Solutionbank M2

Edexcel AS and A Level Modular Mathematics

Exercise B, Question 5

Question:

A uniform horizontal beam AB of mass 5 kg is freely hinged to a vertical wall and is supported by a rod CD as shown in the diagram.

Given that the tension in the rod is 80 N ,

$AC = 1\text{ m}$ and the angle between the rod and the vertical is 45° , find the length of the beam.

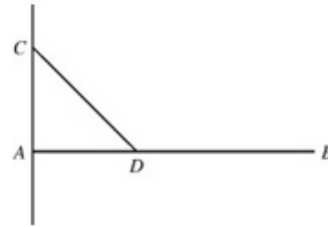

Solution:

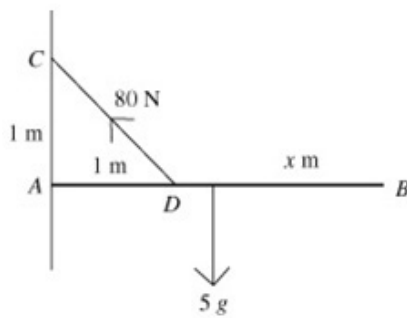

Suppose that the length of AB is $2x\text{ m}$.

$$M(A) \quad 5g \times x = 80 \cos 45^\circ \times 1$$

$$x = \frac{80 \cos 45^\circ}{5g} = 1.15\dots\text{ m}$$

The length of AB is 2.31 m .

Solutionbank M2

Edexcel AS and A Level Modular Mathematics

Exercise B, Question 6

Question:

$ABCD$ is a uniform rectangular lamina with mass 5 kg , side $AB = 1 \text{ m}$, and side $AD = 2 \text{ m}$.

It is hinged at A so that it is free to move in a vertical plane. It is maintained in equilibrium, with B vertically below A , by a horizontal force acting at C and a vertical force acting at D , each of magnitude $F \text{ N}$. Find

- the value of F ,
- the magnitude and direction of the force exerted by the hinge on the lamina.

Solution:

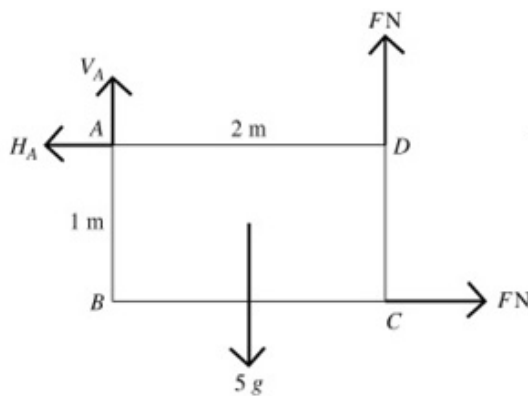

$$\begin{aligned} \mathbf{a} \quad M(A) \quad 5g \times 1 &= F \times 1 + F \times 2 = 3F \\ F &= \frac{5}{3}g = 16.3 \text{ N} \end{aligned}$$

$$\mathbf{b} \quad R(\rightarrow) \quad H_A = F = \frac{5g}{3} \text{ N}$$

$$R(\uparrow) \quad V_A + F = 5g.$$

$$V_A = 5g - F = \frac{10}{3}g \text{ N}$$

$$\text{Magnitude} = \frac{5g}{3} \sqrt{1^2 + 2^2} = 36.5 \text{ N}$$

Direction $\tan^{-1} \frac{1}{2} = 26.6^\circ$ to the vertical away from the lamina.

Solutionbank M2

Edexcel AS and A Level Modular Mathematics

Exercise B, Question 7

Question:

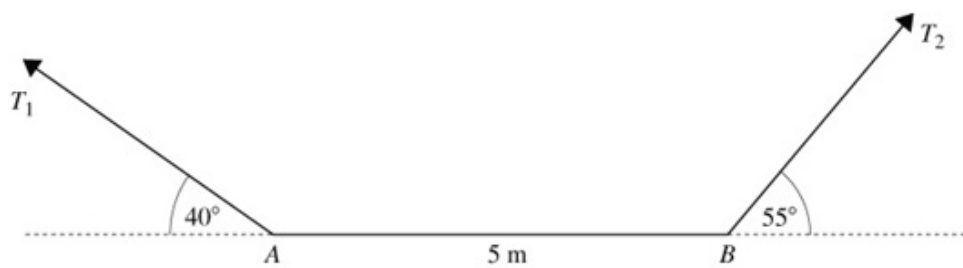

A uniform rod AB of mass 3 kg and length 2 m rests horizontally in equilibrium supported by two strings attached at the ends of the rod. The strings make angles of 40° and θ with the horizontal, as shown in the diagram. Find the magnitudes of the tensions in the strings and the value of θ .

Solution:

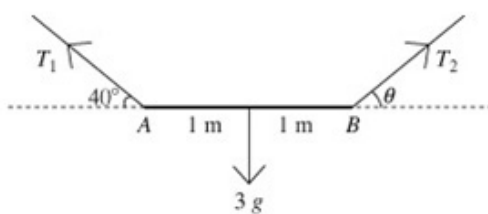

$$M(B) \quad T_1 \times \sin 40^\circ \times 2 = 3g \times 1$$

$$T_1 = \frac{3g}{2 \sin 40^\circ} = 22.9\text{ N}$$

$$R(\uparrow) \quad T_1 \sin 40^\circ + T_2 \sin \theta = 3g$$

Using the moments equation:

$$\frac{3}{2}g + T_2 \sin \theta = 3g \Rightarrow T_2 \sin \theta = \frac{3}{2}g$$

$$R(\rightarrow) \quad T_1 \cos 40^\circ = T_2 \cos \theta = \frac{3g}{2 \sin \theta} \cos \theta$$

But we know that $T_1 = \frac{3g}{2 \sin 40^\circ}$ so we can deduce that $\cot 40^\circ = \cot \theta, \theta = 40^\circ$.

Thus $T_2 = 22.9\text{ N}$.

Solutionbank M2

Edexcel AS and A Level Modular Mathematics

Exercise B, Question 8

Question:

A non-uniform horizontal beam AB of mass 5 kg and length 3 m is freely hinged to a vertical wall and is supported by a rod CD as shown in the diagram. Given that the thrust in the rod is 35 N , $AC = 1 \text{ m}$ and the angle between the rod and the vertical is 45° , find the distance of the centre of mass of the beam from A .

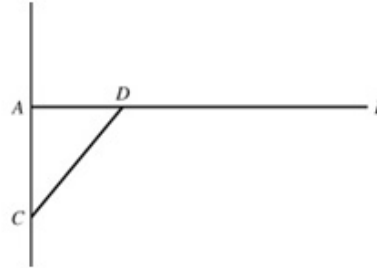

Solution:

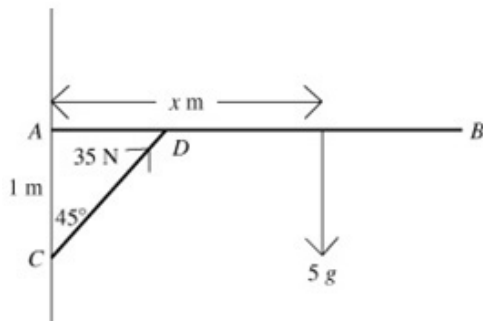

Suppose that the centre of mass is $x \text{ m}$ from A . We are not told anything about any force(s) acting at A , but as they have zero moment about A this will not matter.

$$M(A) \quad 35 \cos 45^\circ \times 1 = 5g \times x$$

$$x = \frac{35 \cos 45^\circ}{5g} \approx 0.51 \text{ m}$$

Solutionbank M2

Edexcel AS and A Level Modular Mathematics

Exercise B, Question 9

Question:

$PQRS$ is a uniform square lamina of side 3 m and mass 6 kg. It is freely hinged at P so that it is free to move in a vertical plane. It is maintained in equilibrium, with PR horizontal, and Q above S , by a force of magnitude F N acting along SR and a force of magnitude $2F$ N acting along RQ . Find

- the value of F ,
- the magnitude and direction of the force exerted by the hinge on the lamina.

Solution:

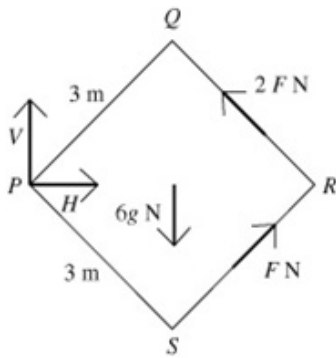

- a** PQR is an isosceles triangle with two sides of 3 m, so the length of PR is $3\sqrt{2}$ m.

$$M(P) \quad 6g \times \frac{3\sqrt{2}}{2} = 2F \times 3 + F \times 3 = 9F$$

$$F = g\sqrt{2} \approx 13.9 \text{ N}$$

- b** $R(\rightarrow) \quad H + F \cos 45^\circ = 2F \cos 45^\circ,$
 $H = F \cos 45^\circ = g = 9.8 \text{ N}$
 $R(\uparrow) \quad V + 2F \cos 45^\circ + F \cos 45^\circ = 6g$
 $V = 6g - 3F \cos 45^\circ = 3g = 29.4 \text{ N}$
 \Rightarrow Magnitude of the combined force

$$= \sqrt{9.8^2 + 29.4^2} = \sqrt{960.4} = 31.0 \text{ N}$$

The resultant force is acting at angle

$$\tan^{-1} \frac{9.8}{29.4} = \tan^{-1} \frac{1}{3} = 18.4^\circ \text{ to the upward vertical at } P.$$

Solutionbank M2

Edexcel AS and A Level Modular Mathematics

Exercise B, Question 10

Question:



A non-uniform rod AB of mass 5 kg and length 4 m , with a particle of mass 2 kg attached at B , rests horizontally in equilibrium supported by two strings attached at the ends of the rod.

The strings make angles of 30° and 45° with the horizontal, as shown in the diagram.

Find

- the tensions in each of the strings,
- the position of the centre of mass of the rod.

Solution:

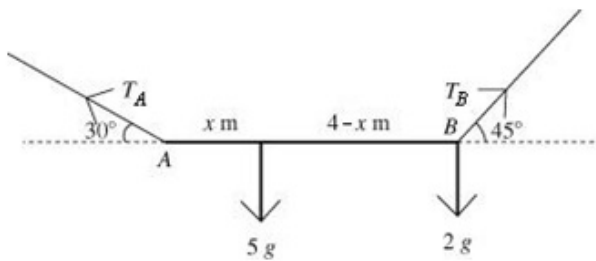

$$\text{a } R(\rightarrow) T_A \cos 30^\circ = T_B \cos 45^\circ,$$

$$T_A \frac{\sqrt{3}}{2} = T_B \frac{1}{\sqrt{2}}, T_A = \frac{\sqrt{2}}{\sqrt{3}} T_B$$

$$R(\uparrow) T_A \sin 30^\circ + T_B \sin 45^\circ = 5g + 2g = 7g$$

$$T_A \times \frac{1}{2} + T_B \times \frac{1}{\sqrt{2}} = T_B \times \left(\frac{1}{2} \times \frac{\sqrt{2}}{\sqrt{3}} + \frac{1}{\sqrt{2}} \right) = 7g$$

$$T_B = 61.5\text{ N and } T_A = 50.2\text{ N}$$

- Suppose that the centre of mass is $x\text{ m}$ from A .

$$M(A) \quad 5g \times x + 2g \times 4 = T_B \times \sin 45^\circ \times 4$$

$$x = \frac{T_B \times \frac{1}{\sqrt{2}} \times 4 - 8g}{5g}$$

$$x = 1.95\text{ m}$$

Solutionbank M2

Edexcel AS and A Level Modular Mathematics

Exercise C, Question 1

Question:

Use the method described in Example 4 to answer the questions in this exercise.
Whenever a numerical value of g is required, take $g = 9.8 \text{ m s}^{-2}$.

A non-uniform rod AB , of mass 4 kg and length 6 m , rests horizontally in equilibrium supported by two strings attached at the ends of the rod. The strings make angles of 30° and 50° with the horizontal, as shown in the diagram. Find

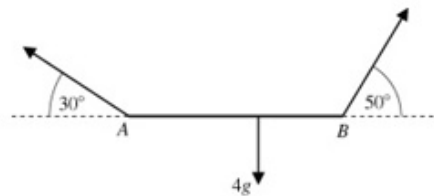

- the position of the centre of mass of the rod,
- the tensions in the two strings.

Solution:

Three forces – the lines of action must be concurrent:

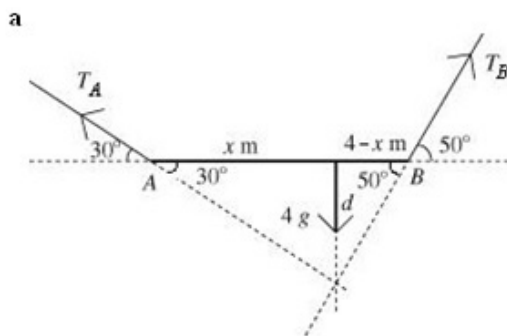

d is common to two triangles, so

$$d = x \sin 30^\circ = (4 - x) \sin 50^\circ$$

$$x(\sin 30^\circ + \sin 50^\circ) = 4 \sin 50^\circ$$

$$x = \frac{4 \sin 50^\circ}{\sin 30^\circ + \sin 50^\circ} = 2.42 \text{ m from } A$$

- b** Triangle of forces:

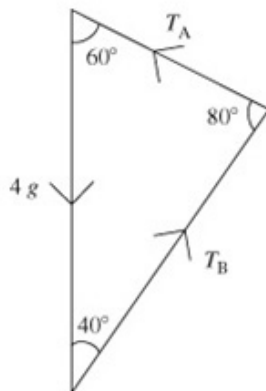

Using the sine rule:

$$\frac{T_A}{\sin 40^\circ} = \frac{T_B}{\sin 60^\circ} = \frac{4g}{\sin 80^\circ}$$

$$T_A = \frac{4g \sin 40^\circ}{\sin 80^\circ} = 25.6 \text{ N and}$$

$$T_B = \frac{4g \sin 60^\circ}{\sin 80^\circ} = 34.5 \text{ N}$$

Solutionbank M2

Edexcel AS and A Level Modular Mathematics

Exercise C, Question 2

Question:

A uniform rod AB of mass 5 kg and length 3 m is freely hinged to a vertical wall at A . The rod is maintained in horizontal equilibrium by a force $P\text{ N}$ acting at B , as shown in the diagram. Find

- the magnitude of P ,
- the magnitude and direction of the reaction of the force exerted by the hinge on the rod.

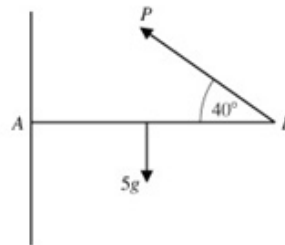

Solution:

- Three forces – the lines of action must be concurrent:

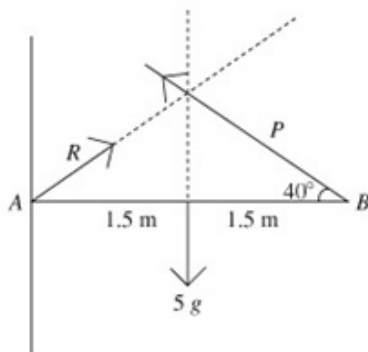

Because the rod is uniform we know that the centre of mass is at the mid-point of the rod. This implies a symmetrical diagram (isosceles triangle), so we know that R acts at 40° to the rod and the magnitudes of P and R are equal.

- Triangle of forces:

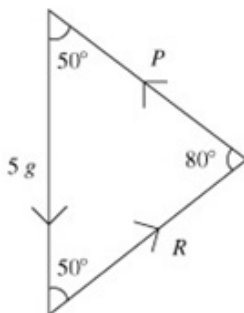

Using the sine rule:

$$\frac{R}{\sin 50^\circ} = \frac{P}{\sin 50^\circ} = \frac{5g}{\sin 80^\circ}$$

$$R = P = \frac{5g \sin 50^\circ}{\sin 80^\circ} = 38.1\text{ N}$$

Alternatively, using the fact that the triangle is isosceles,

$$\frac{5g}{2} = \cos 50^\circ, P = \frac{5g}{2 \cos 50^\circ} = 38.1\text{ N}$$

Solutionbank M2

Edexcel AS and A Level Modular Mathematics

Exercise C, Question 3

Question:

A window of mass 15 kg and height 120 cm is hinged along its top edge. It is kept open by the thrust from a light strut of length 50 cm attached to the wall and perpendicular to the lower edge of the window. By modelling the window as a uniform lamina, calculate the thrust in the strut and the magnitude and direction of the force exerted on the window by the hinge.

Solution:

Three forces – the lines of action must be concurrent:

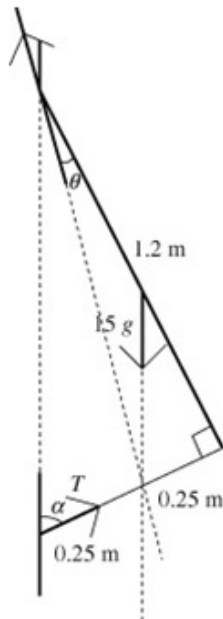

Using the right angled triangles in the diagram,

$$\tan \alpha = \frac{1.2}{0.5}, \alpha = 67.38^\circ$$

$$\tan \theta = \frac{0.25}{1.2}, \theta = 11.77^\circ$$

$$90^\circ - 67.38^\circ - 11.77^\circ = 10.85^\circ$$

$$90^\circ + 11.77^\circ = 101.77^\circ$$

Triangle of forces:

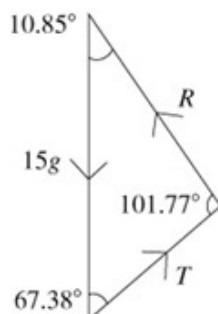

Using the sine rule:

$$\frac{R}{\sin 67.38^\circ} = \frac{T}{\sin 10.85^\circ} = \frac{15g}{\sin 101.77^\circ}$$

$$R = \frac{15g \sin 67.38^\circ}{\sin 101.77^\circ} = 139 \text{ N and}$$

$$T = \frac{15g \sin 10.85^\circ}{\sin 101.77^\circ} = 28.3 \text{ N}$$

R acts at 10.9° to the upward vertical.

Solutionbank M2

Edexcel AS and A Level Modular Mathematics

Exercise C, Question 4

Question:

A uniform rod AB of weight 20 N and length 3 m is freely hinged to a vertical wall at A . A force P is applied at B at right angles to the rod in order to keep the rod in equilibrium at an angle of 30° to the horizontal with B above A . Find

- the magnitude of P ,
- the magnitude and direction of the reaction at the hinge.

Solution:

Three forces – the lines of action must be concurrent:

a

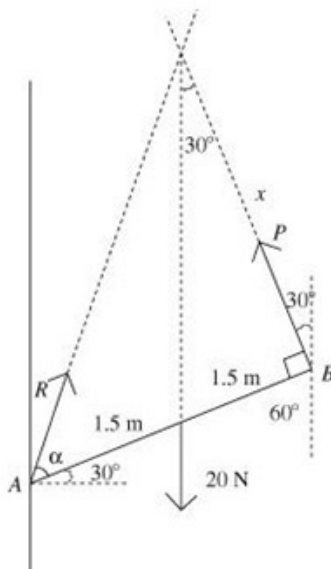

x lies in two right angled triangles:

$$\frac{x}{3} = \tan \alpha \quad \text{and} \quad \frac{1.5}{x} = \tan 30^\circ$$

So

$$x = \frac{1.5}{\tan 30^\circ} \quad \text{and}$$

$$\tan \alpha = \frac{1.5}{3 \tan 30^\circ} = \frac{\sqrt{3}}{2}$$

$$\alpha = 40.89\dots^\circ$$

$$90^\circ - 30^\circ - 40.89^\circ = 19.11^\circ$$

$$180^\circ - 30^\circ - 19.11^\circ = 130.89^\circ$$

b Triangle of forces:

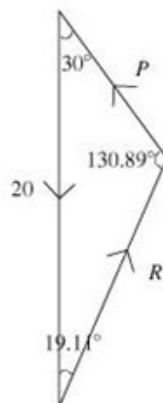

Using the sine rule:

$$\frac{P}{\sin 19.11^\circ} = \frac{R}{\sin 30^\circ} = \frac{20}{\sin 130.89^\circ}$$

$$P = \frac{20 \sin 19.11^\circ}{\sin 130.89^\circ} = 8.7\text{ N and}$$

$$R = \frac{20 \sin 30^\circ}{\sin 130.89^\circ} = 13.2\text{ N acting at } 19.11^\circ$$

to the upward vertical.

Solutionbank M2

Edexcel AS and A Level Modular Mathematics

Exercise C, Question 5

Question:

AB is a loaded shelf freely hinged to the wall at A , and supported in a horizontal position by a light strut CD , which is attached to the shelf at D , 25 cm from A , and attached to the wall at C , 25 cm below A . The total weight of the shelf and its load is 80 N, and the centre of mass is 20 cm from A . Find the thrust in the strut and the magnitude and direction of the force exerted by the hinge on the shelf.

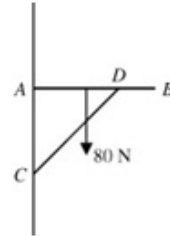

Solution:

- the lines of action must be concurrent:

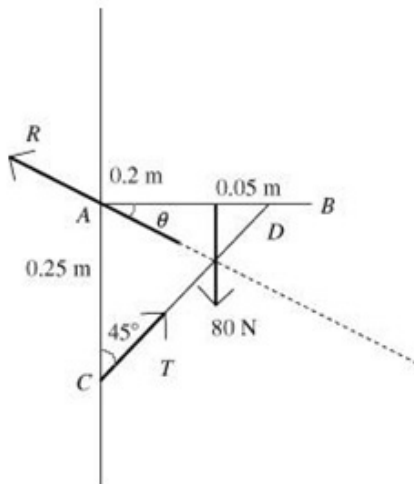

The isosceles right angled triangle ADC gives us angles of 45° .

$$\text{Therefore } \tan \theta = \frac{0.05}{0.2} = \frac{1}{4}$$

$$\theta = \tan^{-1} 0.25 = 11.31^\circ$$

$$90^\circ - 11.31^\circ = 78.69^\circ$$

$$180^\circ - 78.69^\circ - 45^\circ = 56.31^\circ$$

Triangle of forces:

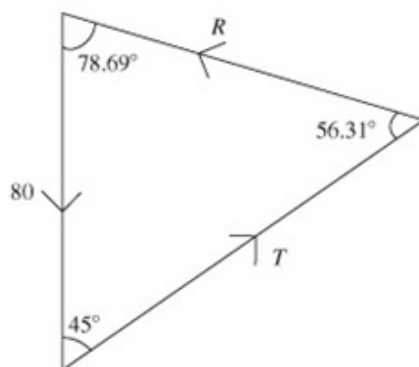

Using the sine rule:

$$\frac{R}{\sin 45^\circ} = \frac{T}{\sin 78.69^\circ} = \frac{80}{\sin 56.31^\circ}$$

$$R = \frac{80 \sin 45^\circ}{\sin 56.31^\circ} = 68.0 \text{ N at } 78.69^\circ \text{ to the}$$

upward vertical and

$$T = \frac{80 \sin 78.69^\circ}{\sin 56.31^\circ} = 94.3 \text{ N}$$

Solutionbank M2

Edexcel AS and A Level Modular Mathematics

Exercise C, Question 6

Question:

A uniform rod XY of mass 6 kg is suspended from the ceiling by light inextensible strings attached to its ends. The rod is resting in equilibrium at 10° to the horizontal with X below Y . The string attached to Y is at an angle of 35° to the vertical. Find

- a the angle that the other string makes with the vertical,
- b the tensions in the two strings.

Solution:

- a Three forces – the lines of action must be concurrent:

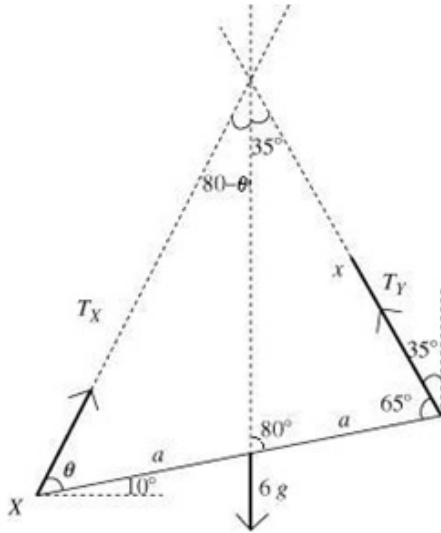

Suppose that the rod has length $2a$.
 x lies in two triangles:

$$\frac{x}{\sin 80^\circ} = \frac{a}{\sin 35^\circ}, x = \frac{a \sin 80^\circ}{\sin 35^\circ} \text{ and}$$

$$\frac{x}{\sin \theta} = \frac{2a}{\sin(115^\circ - \theta)}, x = \frac{2a \sin \theta}{\sin(115^\circ - \theta)}$$

$$\frac{a \sin 80^\circ}{\sin 35^\circ} = \frac{2a \sin \theta}{\sin(115^\circ - \theta)}$$

$$\frac{\sin 80^\circ}{\sin 35^\circ} = \frac{2 \sin \theta}{\sin 115^\circ \cos \theta - \cos 115^\circ \sin \theta}$$

(Cancelling the a and using the expansion for $\sin(A+B)$)

$$\sin 80^\circ (\sin 115^\circ \cos \theta - \cos 115^\circ \sin \theta) = 2 \sin \theta \cos 35^\circ$$

(Cross-multiplying.)

$$\cos \theta (\sin 80^\circ \sin 115^\circ) = \sin \theta (2 \sin 35^\circ + \sin 80^\circ \cos 115^\circ)$$

(Rearrange and collect like terms.)

so

$$\tan \theta = \frac{\sin 80^\circ \sin 115^\circ}{2 \sin 35^\circ + \sin 80^\circ \cos 115^\circ} = 1.22$$

$$\theta = 50.68^\circ$$

\Rightarrow the other string is at $(90^\circ - 10^\circ - 50.68^\circ) = 29.3^\circ$ to the vertical

- b Triangle of forces:

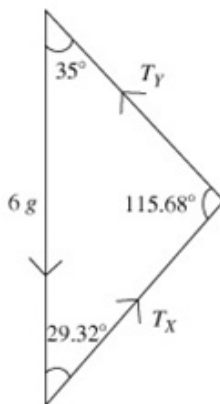

Using the sine rule:

$$\frac{T_x}{\sin 35^\circ} = \frac{T_y}{\sin 29.32^\circ} = \frac{6g}{\sin 115.68^\circ}$$

$$T_x = \frac{6g \sin 35^\circ}{\sin 115.68^\circ} = 37.4 \text{ N and}$$

$$T_y = \frac{6g \sin 29.32^\circ}{\sin 115.68^\circ} = 31.9 \text{ N}$$

Solutionbank M2

Edexcel AS and A Level Modular Mathematics

Exercise D, Question 1

Question:

Whenever a numerical value of g is required, take $g = 9.8 \text{ m s}^{-2}$.

A uniform rod AB of weight 80 N rests with its lower end A on a rough horizontal floor. A string attached to end B keeps the rod in equilibrium.

The string is held at 90° to the rod. The tension in the string is T . The coefficient of friction between the rod and the ground is μ . R is the normal reaction at A and F is the frictional force at A .

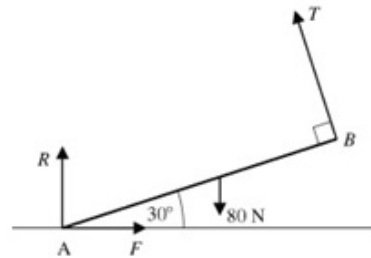

Find the magnitudes of T , R and F , and the least possible value of μ .

Solution:

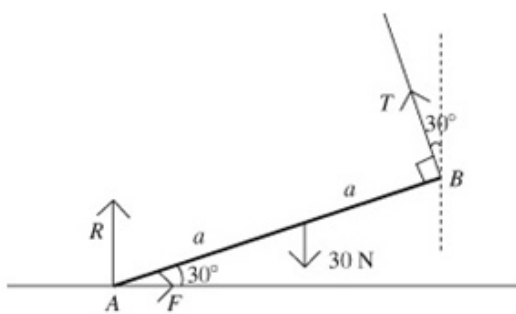

Suppose that the rod has length $2a$.

$$M(A) \quad 2aT = 80 \times a \times \cos 30^\circ$$

Divide by a and substitute for $\cos 30^\circ$

$$2T = 80 \times \frac{\sqrt{3}}{2}, \quad T = 20\sqrt{3} \text{ N}$$

$$R(\rightarrow) \quad T \cos 60^\circ = F = 10\sqrt{3} \text{ N}$$

$$R(\uparrow) \quad T \cos 30^\circ + R = 80$$

$$R = 80 - T \cos 30^\circ = 80 - 10\sqrt{3} \times \frac{\sqrt{3}}{2} \\ = 65 \text{ N}$$

$$F \leq \mu R \Rightarrow 10\sqrt{3} \leq \mu \times 65$$

$$\Rightarrow \mu \geq \frac{10\sqrt{3}}{65} = \frac{2\sqrt{3}}{13}$$

$$\Rightarrow \text{minimum } \mu = 0.27 \text{ (2 s.f.)}$$

Solutionbank M2

Edexcel AS and A Level Modular Mathematics

Exercise D, Question 2

Question:

A uniform ladder of mass 10 kg and length 5 m rests against a smooth vertical wall with its lower end on rough horizontal ground. The ladder rests in equilibrium at an angle of 65° to the horizontal. Find

- the magnitude of the normal contact force S at the wall,
- the magnitude of the normal contact force R at the ground and the frictional force at the ground,
- the least possible value of the coefficient of friction between the ladder and the ground.

Solution:

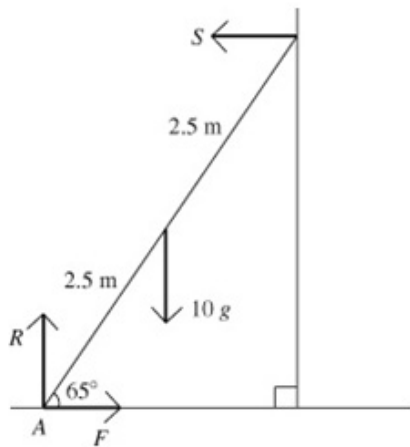

Let A be the end of the ladder on the ground.
 F is the frictional force at A

a

$$M(A) \ 10g \times 2.5 \cos 65^\circ = S \times 5 \sin 65^\circ$$

$$S = \frac{25g \cos 65^\circ}{5 \sin 65^\circ} = 5g \frac{\cos 65^\circ}{\sin 65^\circ} = 22.8 \text{ N}$$

b

$$R(\rightarrow) \ F = S = 22.8 \text{ N}$$

$$R(\uparrow) \ R = 10g = 98 \text{ N}$$

c

$$F \leq \mu R \Rightarrow 22.8 \leq \mu \times 98$$

$$\Rightarrow \mu \geq 0.233 \text{ (3 s.f.)}$$

Solutionbank M2

Edexcel AS and A Level Modular Mathematics

Exercise D, Question 3

Question:

A uniform ladder AB of mass 20 kg rests with its top A against a smooth vertical wall and its base B on rough horizontal ground. The coefficient of friction between the ladder and the ground is $\frac{3}{4}$. A mass of 10 kg is attached to the ladder. Given that the ladder is about to slip, find the inclination of the ladder to the horizontal

- if the 10 kg mass is attached at A ,
- if the 10 kg mass is attached at B .

Solution:

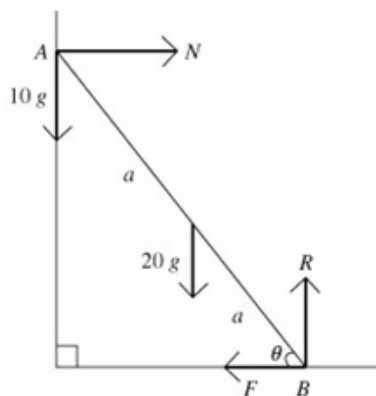

N is the normal reaction at A ,

R is the normal reaction at B , and

F is the frictional force at B .

Moving the 10 kg mass to B :

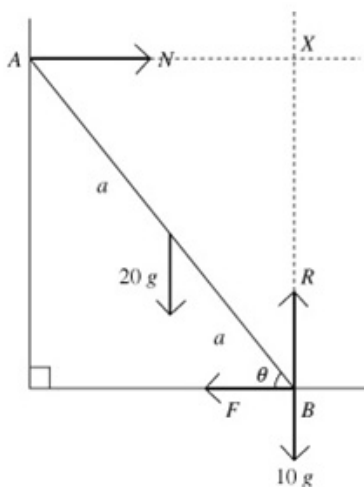

Let the ladder have length $2a$, and be inclined at θ to the horizontal.

a
 $R(\uparrow) \quad R = 30g$

$$M(A) \quad 20g \times a \cos \theta + F \times 2a \sin \theta = R \times 2a \cos \theta$$

Dividing through by a and substituting for R

$$\Rightarrow 20g \cos \theta + 2F \sin \theta = 60g \cos \theta$$

$$2F \sin \theta = 40g \cos \theta$$

$$F = \frac{20g \cos \theta}{\sin \theta}$$

$$F = \mu R \Rightarrow \frac{20g}{\tan \theta} = \frac{3}{4} \times 30g$$

$$\tan \theta = \frac{2}{3} \times \frac{4}{3} = \frac{8}{9}, \theta = 41.6^\circ$$

b

$$R(\uparrow) \quad R = 30g$$

X is the point where the lines of action of N and R meet.

$$M(X) \quad 20g \times a \cos \theta = F \times 2a \sin \theta$$

Dividing through by a and rearranging

$$\Rightarrow F = \frac{20g \cos \theta}{2 \sin \theta} = \frac{10g}{\tan \theta}$$

$$F = \mu R \Rightarrow \frac{10g}{\tan \theta} = \frac{3}{4} \times 30g$$

$$\tan \theta = \frac{4}{9}, \theta = 24.0^\circ$$

Solutionbank M2

Edexcel AS and A Level Modular Mathematics

Exercise D, Question 4

Question:

A uniform ladder of mass 20 kg and length 8 m rests against a smooth vertical wall with its lower end on rough horizontal ground. The coefficient of friction between the ground and the ladder is 0.3. The ladder is inclined at an angle θ to the horizontal, where $\tan \theta = 2$.

A boy of mass 30 kg climbs up the ladder. Find how far up the ladder he can climb without it slipping.

Solution:

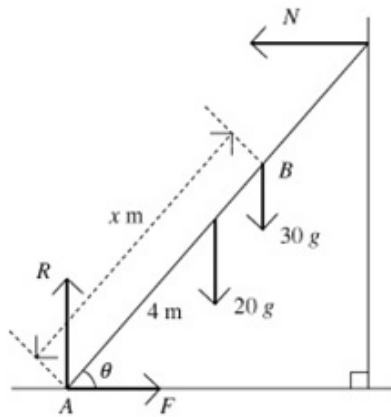

Suppose that the boy reaches the point B , distance x from A , the end of the ladder in contact with the ground.

When the ladder is in limiting equilibrium,

$$F = \mu R \Rightarrow F = 0.3R$$

$$R(\rightarrow) \quad F = N, R(\uparrow) \quad R = 50g$$

$$M(A) \quad 20g \times 4 \cos \theta + 30g \times x \cos \theta = N \times 8 \sin \theta$$

Dividing through by $8 \sin \theta$:

$$N \tan \theta = \frac{80g + 30gx}{8}$$

Substituting for $\tan \theta$:

$$N = \frac{80g + 30gx}{16} = F$$

$$\mu = 0.3 \Rightarrow \frac{80g + 30gx}{16} = 0.3 \times 50g$$

$$8 + 3x = 1.5 \times 16 = 24$$

$$3x = 16, x = 5\frac{1}{3} \text{ m}$$

Solutionbank M2

Edexcel AS and A Level Modular Mathematics

Exercise D, Question 5

Question:

A smooth horizontal rail is fixed at a height of 3 m above a rough horizontal surface. A uniform pole AB of weight 4 N and length 6 m is resting with end A on the rough ground and touching the rail at point C .

The vertical plane containing the pole is perpendicular to the rail. The distance AC is 4.5 m and the pole is in limiting equilibrium. Calculate

- the magnitude of the force exerted by the rail on the pole,
- the coefficient of friction between the pole and the ground.

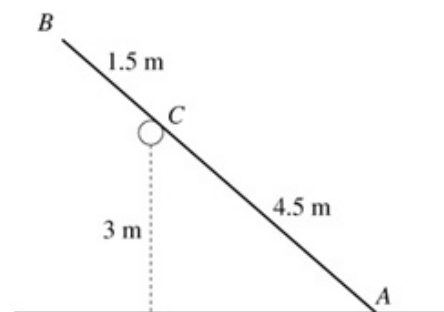

Solution:

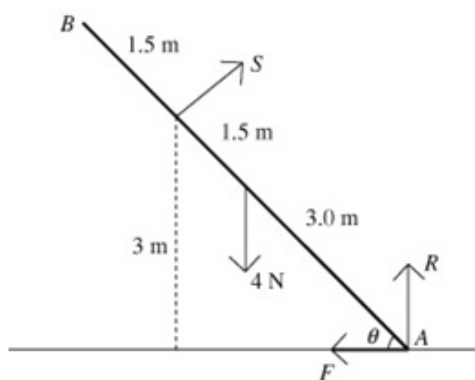

S is the normal reaction at C ,

R is the normal reaction at A , and

F is the friction at A .

θ is the angle between the pole and the ground.

a

$$M(A) \quad 4.5S = 4 \times 3 \cos \theta$$

$$\text{From the diagram, } \sin \theta = \frac{3}{4.5} = \frac{2}{3},$$

$$\Rightarrow \cos \theta = \frac{\sqrt{9-4}}{3} = \frac{\sqrt{5}}{3}$$

$$4.5S = \frac{12\sqrt{5}}{3} = 4\sqrt{5}, S = \frac{8\sqrt{5}}{9} \text{ N}$$

b

$$R(\rightarrow) \quad F = S \sin \theta = \frac{8\sqrt{5}}{9} \times \frac{2}{3} = \frac{16\sqrt{5}}{27}$$

$$R(\uparrow) \quad R + S \cos \theta = 4$$

$$R = 4 - \frac{8\sqrt{5}}{9} \times \frac{\sqrt{5}}{3} = 4 - \frac{40}{27} = \frac{68}{27}$$

$$F = \mu R \Rightarrow \frac{16\sqrt{5}}{27} = \mu \times \frac{68}{27}$$

$$\mu = \frac{16\sqrt{5}}{68} = \frac{4\sqrt{5}}{17} \approx 0.526 \text{ (3 s.f.)}$$

Solutionbank M2

Edexcel AS and A Level Modular Mathematics

Exercise D, Question 6

Question:

A uniform ladder rests in limiting equilibrium with its top against a smooth vertical wall and its base on a rough horizontal floor. The coefficient of friction between the ladder and the floor is μ . Given that the ladder makes an angle θ with the floor, show that $2\mu \tan \theta = 1$.

Solution:

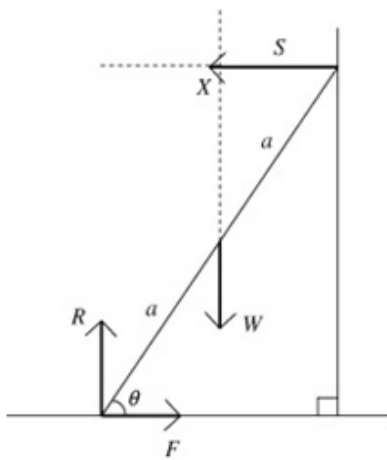

Suppose that the ladder has length $2a$ and weight W .

S is the normal reaction at the wall, R is the normal reaction at the floor, and F is the friction at the floor. X is the point where the lines of action of W and S meet.

$$M(X) \quad 2a \sin \theta \times F = R \times a \cos \theta,$$

$$2F \sin \theta = R \cos \theta$$

The ladder is in limiting equilibrium, so

$$F = \mu R$$

$$\Rightarrow 2\mu R \sin \theta = R \cos \theta$$

$$2\mu \sin \theta = \cos \theta$$

$$\frac{2\mu \sin \theta}{\cos \theta} = 1$$

$$2\mu \tan \theta = 1$$

Solutionbank M2

Edexcel AS and A Level Modular Mathematics

Exercise D, Question 7

Question:

A uniform ladder AB has length 7 m and mass 20 kg. The ladder is resting against a smooth cylindrical drum at P , where AP is 5 m, with end A in contact with rough horizontal ground. The ladder is inclined at 35° to the horizontal.

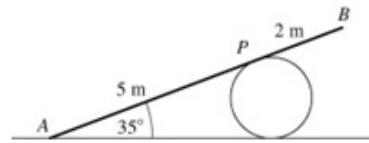

Find the normal and frictional components of the contact force at A , and hence find the least possible value of the coefficient of friction between the ladder and the ground.

Solution:

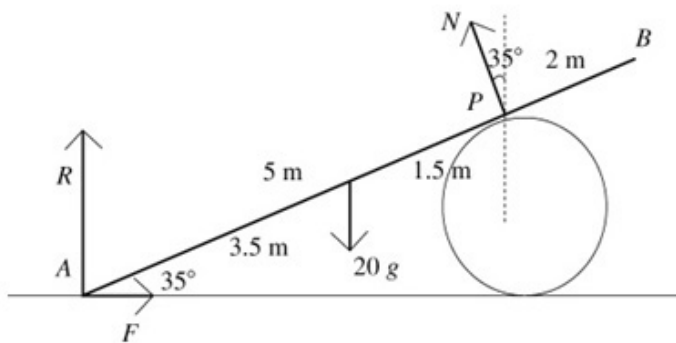

N is the normal reaction at P , R is the normal reaction at A and F is the friction at A .

$$M(A) \quad 20g \times 3.5 \cos 35^\circ = 5N$$

$$\Rightarrow N = \frac{20g \times 3.5 \cos 35^\circ}{5} = 14g \cos 35^\circ$$

$$R(\uparrow) \quad N \cos 35^\circ + R = 20g$$

$$R = 20g - 14g \cos 35^\circ \times \cos 35^\circ = 103.9 \dots \text{ N}$$

$$R(\rightarrow) \quad F = N \sin 35^\circ = 14g \cos 35^\circ \sin 35^\circ = 64.46 \dots \text{ N}$$

$$F \leq \mu R$$

$$\Rightarrow 14g \cos 35^\circ \sin 35^\circ \leq \mu(20g - 14g \cos^2 35^\circ)$$

$$\Rightarrow \mu \geq \frac{14 \cos 35^\circ \sin 35^\circ}{20 - 14 \cos^2 35^\circ}$$

$$\mu \geq 0.620 \text{ (3 s.f.)}$$

Least possible value is 0.620 (3 s.f.).

Solutionbank M2

Edexcel AS and A Level Modular Mathematics

Exercise D, Question 8

Question:

A uniform ladder rests in limiting equilibrium with one end on rough horizontal ground and the other end against a rough vertical wall. The coefficient of friction between the ladder and the ground is μ_1 and the coefficient of friction between the ladder and the wall is μ_2 . Given that the ladder makes an angle θ with the

horizontal, show that $\tan \theta = \frac{1 - \mu_1 \mu_2}{2\mu_1}$.

Solution:

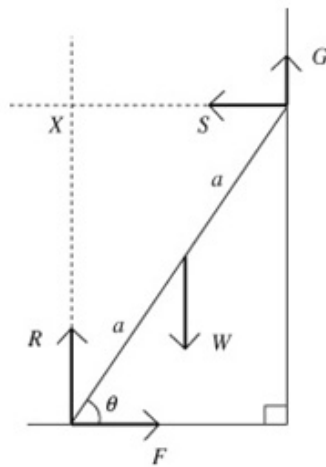

R and F are the normal reaction and the friction where the ladder is in contact with the ground. S and G are the normal reaction and the friction at the wall.

X is the point where the lines of action of R and S meet.

Suppose that the ladder has length $2a$ and weight W .

As the ladder rests in limiting equilibrium,

$$F = \mu_1 R \text{ and } G = \mu_2 S.$$

$$M(X)W \times a \cos \theta = F \times 2a \sin \theta + G \times 2a \cos \theta$$

Dividing by $a \cos \theta$ gives

$$W = 2F \tan \theta + 2G$$

$$R(\rightarrow) F = S$$

$$R(\uparrow) W = R + G$$

Substituting for W and F in the moments equation:

$$R + G = 2\mu_1 R \tan \theta + 2G$$

$$\Rightarrow R - G = 2\mu_1 R \tan \theta$$

$$\text{But } G = \mu_2 S = \mu_2 F = \mu_2 \mu_1 R \text{ so}$$

$$R - \mu_1 \mu_2 R = 2\mu_1 R \tan \theta$$

$$\text{Hence } \frac{1 - \mu_1 \mu_2}{2\mu_1} = \tan \theta$$

Solutionbank M2

Edexcel AS and A Level Modular Mathematics

Exercise D, Question 9

Question:

A uniform ladder of weight W rests in equilibrium with one end on rough horizontal ground and the other resting against a smooth vertical wall. The vertical plane containing the ladder is at right angles to the wall and the ladder is inclined at 60° to the horizontal. The coefficient of friction between the ladder and the ground is μ .

- a Find, in terms of W , the magnitude of the force exerted by the wall on the ladder.
- b Show that $\mu \geq \frac{1}{8}\sqrt{3}$.

A load of weight w is attached to the ladder at its upper end (resting against the wall).

- c Given that $\mu = \frac{1}{5}\sqrt{3}$ and that the equilibrium is limiting, find w in terms of W .

Solution:

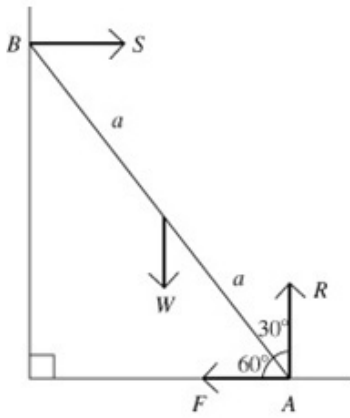

Let A and B be the ends of the ladder.

S is the normal reaction at B , R the

normal reaction at A and F the friction at B .

The length of the ladder is $2a$.

a

$$M(A) \quad W \times a \cos 60^\circ = S \times 2a \cos 30^\circ$$

$$S = \frac{Wa \cos 60^\circ}{2a \cos 30^\circ} = \frac{W \times \frac{1}{2}}{2 \times \frac{\sqrt{3}}{2}} = \frac{W}{2\sqrt{3}}$$

b

$$R(\rightarrow) \quad F = S = \frac{W}{2\sqrt{3}}, \quad R(\uparrow) \quad R = W$$

The ladder is in equilibrium so $F \leq \mu R$,

$$\Rightarrow \frac{W}{2\sqrt{3}} \leq \mu W, \quad \mu \geq \frac{1}{2\sqrt{3}} = \frac{\sqrt{3}}{2 \times 3} = \frac{\sqrt{3}}{6}$$

$$\mu \geq \frac{\sqrt{3}}{6}, \text{ as required.}$$

c

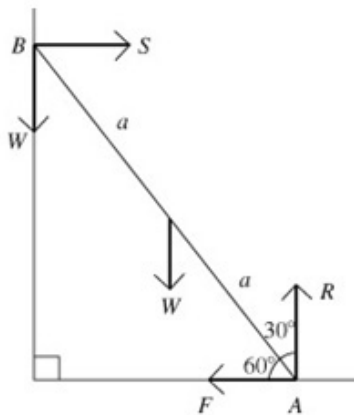

Adding the load at the top of the ladder and using the limiting equilibrium:

$$R(\rightarrow) \quad S = F = \frac{\sqrt{3}R}{5}, \quad R(\uparrow) \quad w + W = R$$

$$M(B) \quad W \times a \cos 60^\circ + F \times 2a \sin 60^\circ = R \times 2a \cos 60^\circ$$

$$\text{i.e. } Wa \times \frac{1}{2} + 2aF \times \frac{\sqrt{3}}{2} = 2aR \times \frac{1}{2}$$

Dividing by $\frac{a}{2}$ and substituting for F :

$$W + 2\sqrt{3} \times \frac{\sqrt{3}R}{5} = 2R$$

$$W = 2R - \frac{6}{5}R = \frac{4}{5}R = \frac{4}{5}(w + W)$$

$$\Rightarrow W - \frac{4}{5}W = \frac{4}{5}w, \quad w = \frac{W}{4}$$

Solutionbank M2

Edexcel AS and A Level Modular Mathematics

Exercise D, Question 10

Question:

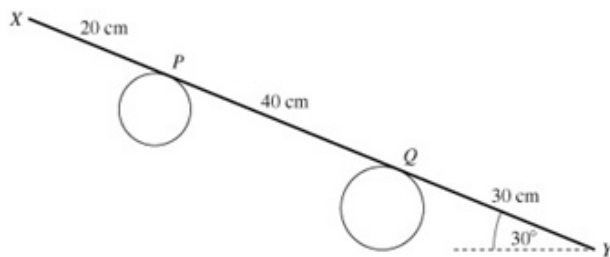

A uniform rod XY has weight 20 N and length 90 cm . The rod rests on two parallel pegs, with X above Y , in a vertical plane which is perpendicular to the axes of the pegs, as shown in the diagram. The rod makes an angle of 30° to the horizontal and touches the two pegs at P and Q , where $XP = 20\text{ cm}$ and $XQ = 60\text{ cm}$.

- a Calculate the normal components of the forces on the rod at P and at Q .
The coefficient of friction between the rod and each peg is μ .
- b Given that the rod is about to slip, find μ .

Solution:

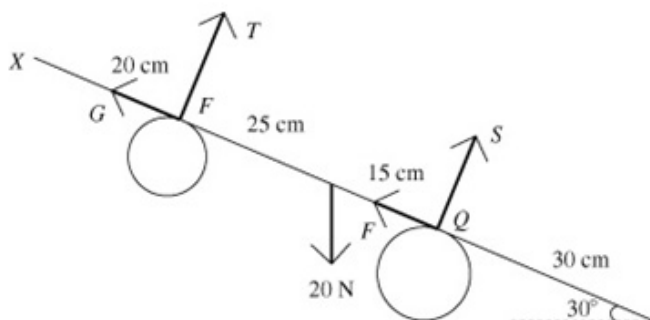

T is the normal force at P ,
 G is the friction at P ,
 S is the normal force at Q ,
 F is the friction at Q .

a

$$M(P) \quad S \times 4 = 20 \times 2.5 \times \cos 30^\circ$$

$$S = \frac{20 \times 2.5 \times \frac{\sqrt{3}}{2}}{4} = \frac{25\sqrt{3}}{4} \text{ N,}$$

$$M(Q) \quad T \times 4 = 20 \times 1.5 \times \cos 30^\circ$$

$$T = \frac{20 \times 1.5 \times \frac{\sqrt{3}}{2}}{4} = \frac{15\sqrt{3}}{4} \text{ N}$$

b

$$R(\searrow) \quad G + F = 20 \cos 60^\circ = 10$$

$$= \mu T + \mu S = \mu \times \frac{40\sqrt{3}}{4} = 10\sqrt{3}\mu$$

as the rod is about to slip.

$$\Rightarrow \mu = \frac{1}{\sqrt{3}}$$

Solutionbank M2

Edexcel AS and A Level Modular Mathematics

Exercise D, Question 11

Question:

The diagram shows the vertical cross section $ABCD$ through the centre of mass of a uniform rectangular box. The box is resting on a rough horizontal floor and leaning against a smooth vertical wall.

The box has mass 25 kg .

$AB = 0.5\text{ m}$, $BC = 1.5\text{ m}$ and AD is at an angle of θ to the horizontal. The coefficient of friction between the box and the ground is $\frac{1}{4}$.

Given that the box is about to slip, find the value of θ .

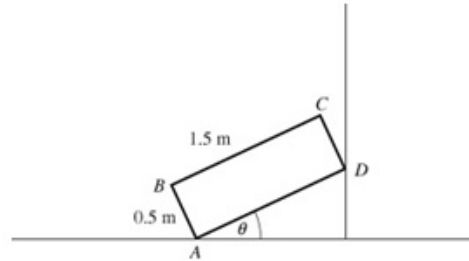

Solution:

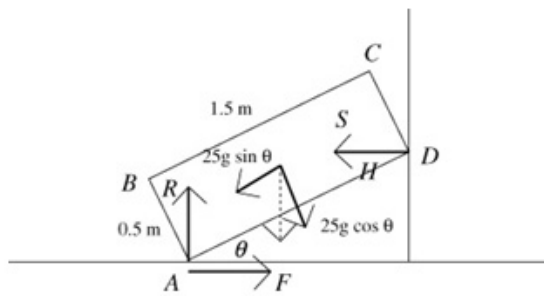

R and S are the normal reactions at A and D respectively. F is the friction at A .

As the box is about to slip, $F = \frac{1}{4}R$.

In order to take moments about A , resolve the weight into components $25g \cos \theta$

R and S are the normal reactions at A and parallel to AB and $25g \sin \theta$ parallel to AD .

$$M(A) \quad S \times 1.5 \sin \theta + 0.25 \times 25g \sin \theta = 25g \cos \theta \times 0.75$$

$$S = \frac{25g \cos \theta \times 0.75 - 25g \sin \theta \times 0.25}{1.5 \sin \theta}$$

$$= \frac{25g(3 \cos \theta - \sin \theta)}{6 \sin \theta}$$

$$R(\rightarrow) \quad F = S = \frac{25g(3 \cos \theta - \sin \theta)}{6 \sin \theta}$$

$$R(\uparrow) \quad R = 25g$$

$$F = \frac{1}{4}R \Rightarrow \frac{3 \cos \theta - \sin \theta}{6 \sin \theta} = \frac{1}{4}$$

so

$$12 \cos \theta - 4 \sin \theta = 6 \sin \theta$$

$$12 \cos \theta = 10 \sin \theta$$

$$\tan \theta = \frac{12}{10} = \frac{6}{5}$$

$$\theta = 50.2^\circ$$

Solutionbank M2

Edexcel AS and A Level Modular Mathematics

Exercise D, Question 12

Question:

A uniform rod of length l has a ring at one end which can slide along a rough horizontal pole. The coefficient of friction between the ring and the pole is 0.2. The other end of the rod is attached to the end of the pole by a light inextensible cord of length l . The rod rests in equilibrium at an angle of θ to the horizontal. Using a geometrical method, or otherwise, find the smallest possible value of θ .

Solution:

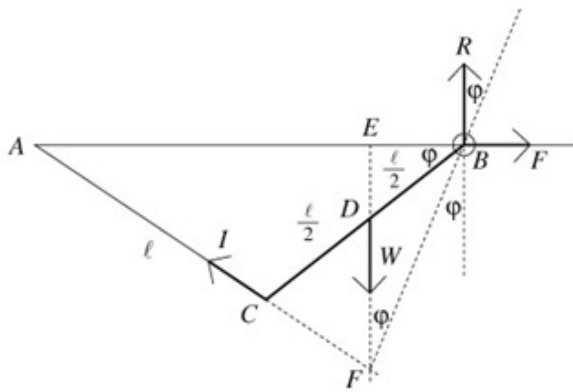

The diagram of forces has four forces acting, the weight, W , the tension, T , in the cord, the normal reaction, R , and the friction, F , at the ring end. Combining R and F to give a single contact force at the ring reduces the problem to one of an object in equilibrium with three forces acting. These must be concurrent.

Triangle ABC is isosceles (2 sides of length l).

Equilibrium $F \leq \mu R, 0.2 \geq \frac{F}{R}$, but

$$\frac{F}{R} = \tan \varphi \Rightarrow 0.2 \geq \tan \varphi = \frac{EB}{EF}$$

$$\text{Triangle } EBD \Rightarrow EB = \frac{l}{2} \cos \theta$$

$$\text{Triangle } AEF \Rightarrow EF = \frac{3l}{2} \sin \theta$$

$$\Rightarrow \frac{EB}{EF} = \frac{\cos \theta}{3 \sin \theta} = \frac{1}{3 \tan \theta} \leq 0.2$$

$$\Rightarrow \tan \theta \geq \frac{1}{3 \times 0.2} = \frac{5}{3}$$

$$\Rightarrow \theta \geq 59.0^\circ$$

Solutionbank M2

Edexcel AS and A Level Modular Mathematics

Exercise E, Question 1

Question:

Whenever a numerical value of g is required, take $g = 9.8 \text{ m s}^{-2}$.

A uniform ladder of mass 20 kg and length 6 m rests with one end on a smooth horizontal floor and the other end against a smooth vertical wall. The ladder is held in this position by a light inextensible rope of length 5 m which has one end attached to the bottom of the ladder and the other end fastened to a point at the base of the wall, vertically below the top of the ladder. Find the tension in the rope.

Solution:

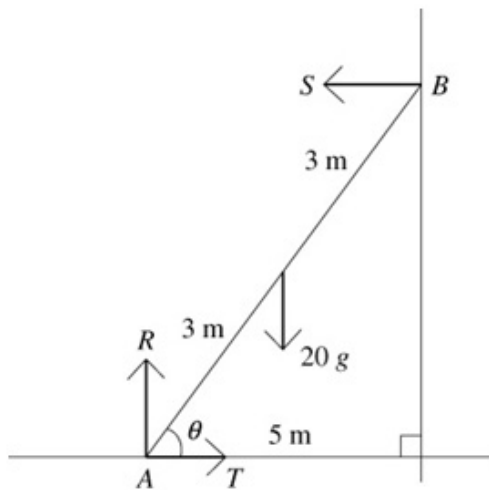

Let A and B be the ends of the ladder.

R is the normal reaction at A ,

S is the normal reaction

at B (both smooth surfaces).

T is the tension in the rope.

The angle between the ladder and the ground is θ .

$$R(\rightarrow) \quad R = 20g$$

$$R(\uparrow) \quad S = T$$

$$M(A) 20g \times 3 \times \cos \theta = S \times 6 \times \sin \theta$$

$$\text{so } 20g \times 3 \times \frac{5}{6} = S \times 6 \times \frac{\sqrt{6^2 - 5^2}}{6}$$

$$50g = \sqrt{11}S$$

$$T = S = \frac{50g}{\sqrt{11}} = 150 \text{ N (2 s.f.)}$$

Solutionbank M2

Edexcel AS and A Level Modular Mathematics

Exercise E, Question 2

Question:

A uniform ladder AB of mass M kg and length 5 m rests with end A on a smooth horizontal floor and end B against a smooth vertical wall. The ladder is held in equilibrium at an angle θ to the floor by a light horizontal string attached to the wall and to a point C on the ladder. If $\tan \theta = 2$, find the tension in the string when the length AC is 2 m.

Solution:

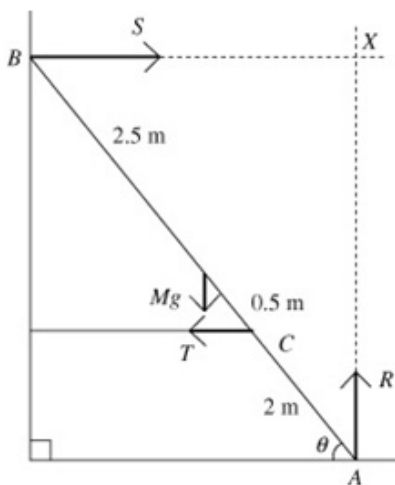

Given $\tan \theta = 2$.

The normal reactions at A and B are R and S respectively.

X is the point where the lines of action of R and S meet.

T is the tension in the string.

$$M(X) \quad Mg \times 2.5 \times \cos \theta = T \times 3 \times \sin \theta$$

(Note that, by taking moments about X we do not need to find out anything about R and S .)

Dividing by $\cos \theta$:

$$\frac{5Mg}{2} = \frac{3T \sin \theta}{\cos \theta} = 3T \tan \theta = 6T$$

$$\text{Therefore } T = \frac{5Mg}{12}$$

Solutionbank M2

Edexcel AS and A Level Modular Mathematics

Exercise E, Question 3

Question:

A uniform pole AB of weight 12 N has its lower end A on rough horizontal ground. The pole is being raised into a vertical position by a rope attached to B . The rope and the pole lie in the same vertical plane and A does not slip across the ground. Find the horizontal and vertical components of the reaction at the ground when the rope is perpendicular to the pole and the pole is at 15° to the horizontal.

Solution:

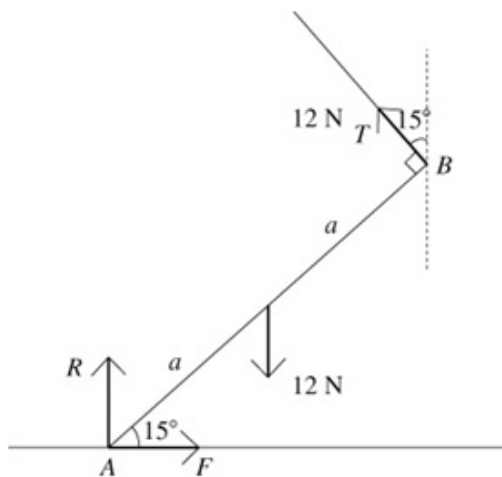

Let the length of the pole be $2a$.

T is the tension in the string.

R is the normal reaction at A , and

F is the force due to friction at A .

$$M(A) \quad 12 \times a \times \cos 15^\circ = T \times 2a$$

$$\Rightarrow T = 6 \cos 15^\circ$$

$$R(\rightarrow) \quad F = T \sin 15^\circ = 6 \cos 15^\circ \sin 15^\circ = 1.5 \text{ N}$$

$$R(\uparrow) \quad R + T \cos 15^\circ = 12$$

$$R = 12 - 6 \cos 15^\circ \times \cos 15^\circ = 6.4 \text{ N (2 s.f.)}$$

Solutionbank M2

Edexcel AS and A Level Modular Mathematics

Exercise E, Question 4

Question:

AB is a light rod of length $5a$ rigidly joined to a light rod BC of length $2a$ so that the rods are perpendicular to each other and in the same vertical plane, as shown in the diagram. The centre, O , of AB is fixed and the rods can rotate freely about O in a vertical plane. A particle of mass $3m$ is attached at A and a particle of mass m is attached at C . The system rests in equilibrium with AB inclined at an acute angle θ to the vertical. Find the value of θ .

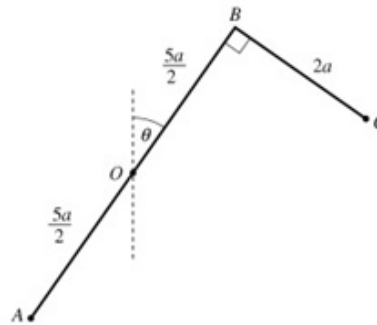

Solution:

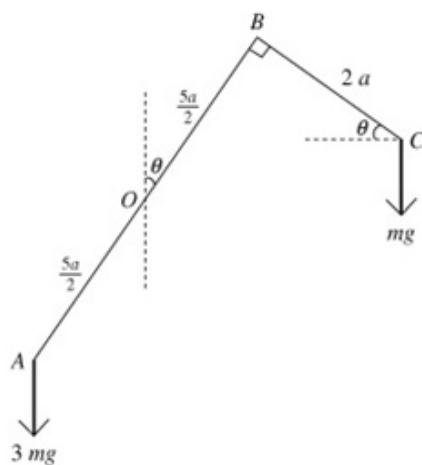

There will be a reaction at O , but if we take moments about O we will not need to know anything about this force.

$$M(O) 3mg \times \frac{5a}{2} \sin \theta = mg \times \left(\frac{5a}{2} \sin \theta + 2a \cos \theta \right)$$

Dividing by mga :

$$\frac{15 \sin \theta}{2} = \frac{5 \sin \theta}{2} + 2 \cos \theta$$

$$\Rightarrow 5 \sin \theta = 2 \cos \theta, \tan \theta = \frac{2}{5}$$

$$\Rightarrow \theta = \tan^{-1} 0.4 = 21.8^\circ$$

Solutionbank M2

Edexcel AS and A Level Modular Mathematics

Exercise E, Question 5

Question:

A uniform ladder AB has one end A on smooth horizontal ground. The other end B rests against a smooth vertical wall. The ladder is modelled as a uniform rod of mass m and length $5a$. The ladder is kept in equilibrium by a horizontal force F acting at a point C of the ladder where $AC = a$. The force F and the ladder lie in a vertical plane perpendicular to the wall. The ladder is inclined to the horizontal at an angle θ , where $\tan \theta = 1.8$, as shown in the diagram.

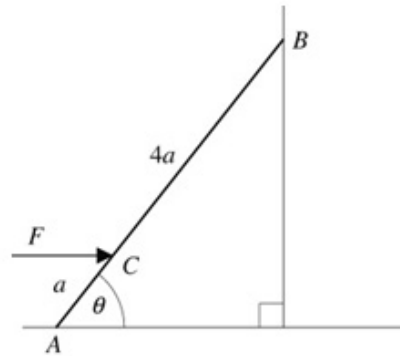

Show that $F = \frac{25mg}{32}$.

Solution:

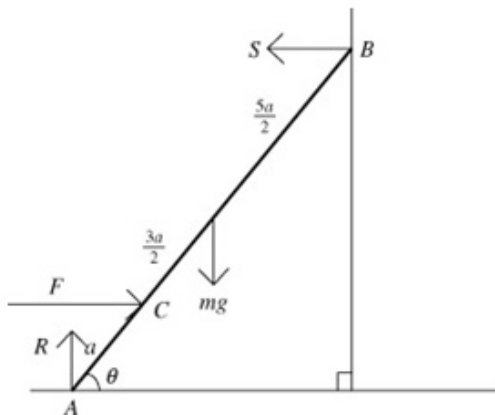

Let S be the force between the ladder and the wall at B .
Let R be the normal reaction at A . (Both surfaces are smooth, so no friction.)

$$R(\rightarrow) \quad F = S$$

$$M(A) \quad mg \times \frac{5a}{2} \times \cos \theta + F \times a \times \sin \theta = S \times 5a \times \sin \theta$$

Dividing through by $a \cos \theta$ gives

$$\frac{5mg}{2} + F \tan \theta = 5S = 5F,$$

$$\text{so } \frac{5mg}{2} = 5F - 1.8F = 3.2F \text{ and}$$

$$F = \frac{5mg}{2 \times 3.2} = \frac{50mg}{64} = \frac{25mg}{32} \text{ as required.}$$

Solutionbank M2

Edexcel AS and A Level Modular Mathematics

Exercise E, Question 6

Question:

A uniform rod AB , of length $12a$ and weight W , is free to rotate in a vertical plane about a smooth pivot at A .

One end of a light inextensible string is attached to B .

The other end is attached to point C which is vertically above A , with $AC = 5a$. The rod is in equilibrium with AB horizontal, as shown in the diagram.

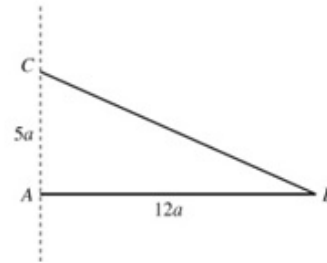

Find, in terms of W ,

- the tension in the string,
- the magnitude of the horizontal component of the force exerted by the pivot on the rod.

Solution:

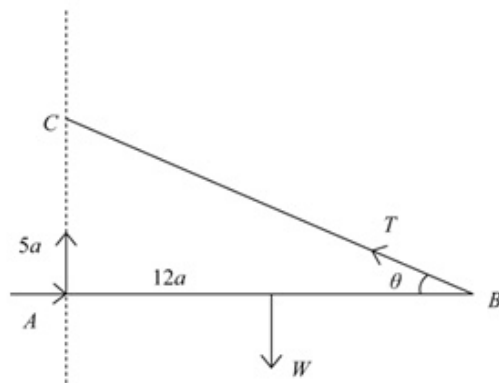

Let the angle between the string and the rod be θ , T be the tension in the string, X the horizontal component of the force at A and Y the vertical component of the force at A .

a

$$\text{M}(A) \quad W \times 6a = T \sin \theta \times 12a = T \times \frac{5}{13} \times 12a$$

(since ABC is a 5, 12, 13 triangle)

$$\text{Giving } T = \frac{W \times 6a \times 13}{5 \times 12a} = \frac{13W}{10}$$

b

$$\text{R}(\rightarrow) \quad X = T \cos \theta = \frac{13W}{10} \times \frac{12}{13} = \frac{6W}{5}$$

Solutionbank M2

Edexcel AS and A Level Modular Mathematics

Exercise E, Question 7

Question:

A uniform ladder AB , of mass m and length $2a$, has one end A on rough horizontal ground. The other end B rests against a smooth vertical wall. The ladder is in a vertical plane perpendicular to the wall. The ladder makes an angle α with the vertical, where $\tan \alpha = \frac{3}{4}$. A child of mass $2m$

stands on the ladder at C where $AC = \frac{2}{3}a$, as shown in the diagram. The ladder and the child are in equilibrium.

By modelling the ladder as a rod and the child as a particle, calculate the least possible value of the coefficient of friction between the ladder and the ground.

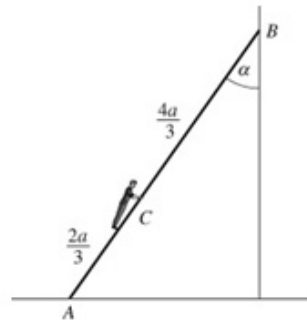

Solution:

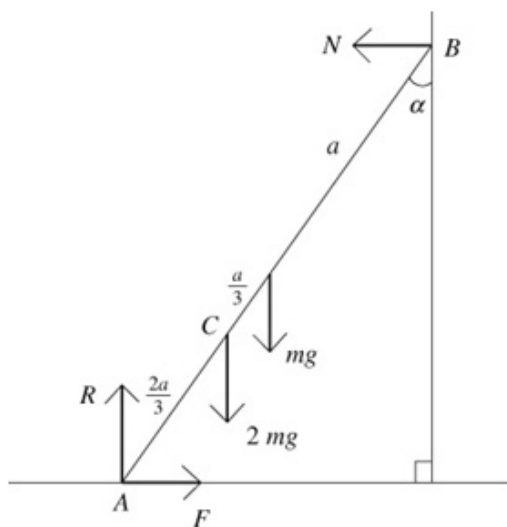

Let N be the force between the ladder and the wall at B – perpendicular to the wall since no friction here. Let R be the normal reaction at A , and F the friction at A .

$$R(\uparrow) \quad R = 3mg$$

$$M(B) \quad mga \sin \alpha + 2mg \times \frac{4a}{3} \times \sin \alpha + F \times 2a \cos \alpha = R \times 2a \sin \alpha$$

Substituting for R , $\sin \alpha$ and $\cos \alpha$:

$$mga \times \frac{3}{5} + \frac{8mga}{3} \times \frac{3}{5} + F \times 2a \times \frac{4}{5} = 6mga \times \frac{3}{5}$$

$$F \times \frac{8a}{5} = \frac{18mga}{5} - \frac{8mga}{5} - \frac{3mga}{5} = \frac{7mga}{5}$$

The ladder and the child are in equilibrium,

$$\text{so } F = \frac{7mga}{5} \times \frac{5}{8a} = \frac{7mg}{8} \leq \mu R$$

$$\Rightarrow \frac{7mg}{8} \leq \mu \times 3mg, \mu \geq \frac{7}{24},$$

the least possible value for μ is $\frac{7}{24}$

Solutionbank M2

Edexcel AS and A Level Modular Mathematics

Exercise E, Question 8

Question:

A uniform steel girder AB of weight 400 N and length 4 m , is freely hinged at A to a vertical wall. The girder is supported in a horizontal position by a steel cable attached to the girder at B . The other end of the cable is attached to the point C vertically above A on the wall, with $\angle ABC = \alpha$ where $\tan \alpha = \frac{1}{2}$. A load of weight 200 N is suspended by another cable from the girder at the point D , where $AD = 3\text{ m}$, as shown in the diagram. The girder remains horizontal and in equilibrium.

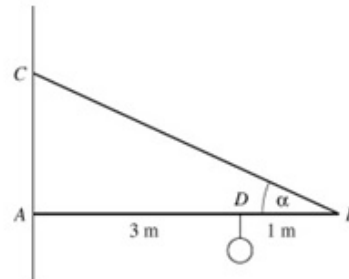

The girder is modelled as a rod, and the cables as light inextensible strings.

- Show that the tension in the cable BC is $350\sqrt{5}\text{ N}$.
- Find the magnitude of the reaction on the girder at A .

Solution:

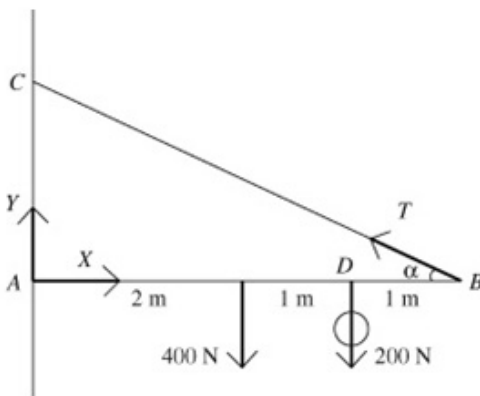

Let the tension in cable BC be T . The horizontal and vertical components of the $\tan \alpha = \frac{1}{2} \Rightarrow \sin \alpha = \frac{1}{\sqrt{5}}$ reaction at A are X and Y respectively.

$$\text{a} \quad \text{M}(A) \quad 400 \times 2 + 200 \times 3 = T \sin \alpha \times 4$$

$$1400 = 4T \times \frac{1}{\sqrt{5}}, T = 350\sqrt{5}\text{ N}$$

$$\text{b} \quad \text{R}(\rightarrow) \quad X = T \cos \alpha = 350\sqrt{5} \times \frac{2}{\sqrt{5}} = 700\text{ N}$$

$$\text{R}(\uparrow) \quad Y = 600 - T \sin \alpha = 600 - 350\sqrt{5} \times \frac{1}{\sqrt{5}} = 250\text{ N}$$

Magnitude of the reaction

$$= \sqrt{700^2 + 250^2} = \sqrt{552500} = 743\text{ N (3 s.f.)}$$

Solutionbank M2

Edexcel AS and A Level Modular Mathematics

Exercise E, Question 9

Question:

A non-uniform rod AB of length l rests horizontally with its ends resting on two smooth surfaces inclined at 20° and 30° to the horizontal, as shown in the diagram. Use a geometrical method to find the distance of the centre of mass from A .

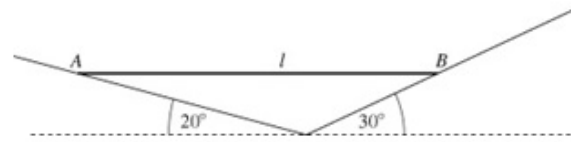

Solution:

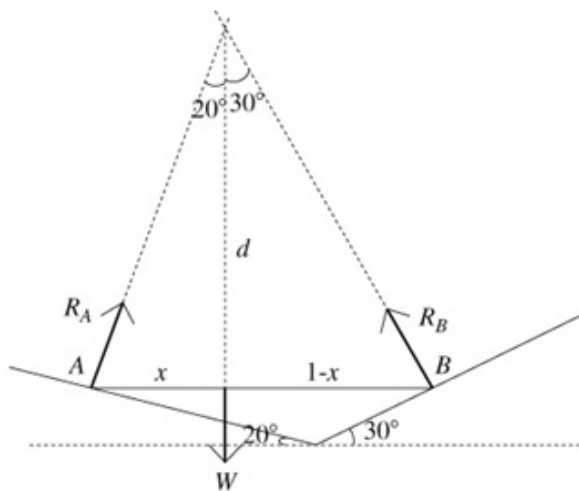

Suppose that the centre of mass is distance x from A .

There are three forces acting, the weight and the two normal reactions, so their lines of action must be concurrent.

The length d lies in 2 separate right angled triangles:

$$\frac{x}{d} = \tan 20^\circ \quad \text{and} \quad \frac{l-x}{d} = \tan 30^\circ$$

$$\Rightarrow \frac{x}{l-x} = \frac{\tan 20^\circ}{\tan 30^\circ}$$

$$x(\tan 30^\circ + \tan 20^\circ) = l \tan 20^\circ$$

$$x = \frac{l \tan 20^\circ}{\tan 30^\circ + \tan 20^\circ} \approx 0.39l \quad (2 \text{ s.f.})$$

Solutionbank M2

Edexcel AS and A Level Modular Mathematics

Exercise E, Question 10

Question:

A uniform ladder, of weight W and length $2a$, rests in equilibrium with one end A on a smooth horizontal floor and the other end B against a rough vertical wall. The ladder is in a vertical plane perpendicular to the wall. The coefficient of friction between the wall and the ladder is μ .

The ladder makes an angle θ with the floor, where

$\tan \theta = \frac{4}{3}$. A horizontal light inextensible string CD is

attached to the ladder at the point C , where $AC = \frac{1}{4}a$. The string is attached to the wall at the point D , with BD

vertical, as shown in the diagram. The tension in the string is $\frac{1}{3}W$. By modelling the ladder as a rod,

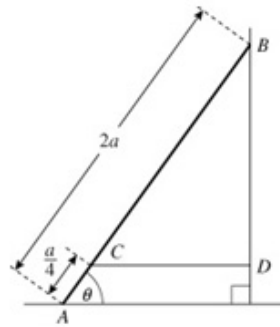

- find the magnitude of the force of the floor on the ladder,
- show that $\mu \geq \frac{1}{3}$.
- State how you have used the modelling assumption that the ladder is a rod.

Solution:

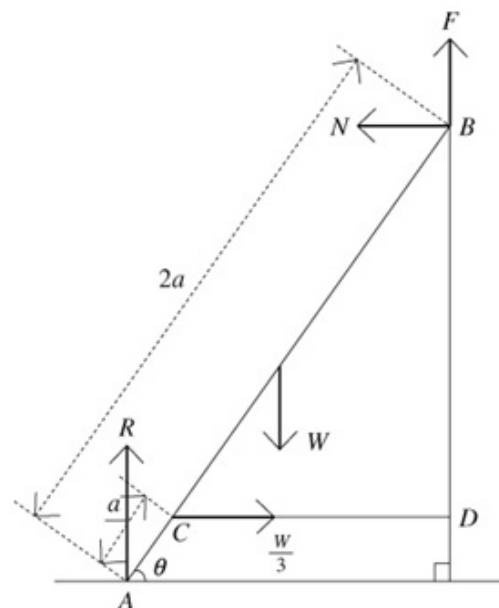

Let R be the normal reaction at A , N the normal reaction at B and F the friction at B .

a

$$M(B) \quad \frac{W}{3} \times \frac{7a}{4} \times \sin \theta + W \times a \times \cos \theta = R \times 2a \times \cos \theta$$

Dividing by $a \cos \theta$ gives

$$2R = \frac{7W}{12} \times \tan \theta + W = \frac{7}{12} \times \frac{4}{3}W + W = \frac{16W}{9}$$

$$\text{So } R = \frac{8W}{9}$$

b

$$R(\rightarrow) \quad N = \frac{W}{3}$$

$$R(\uparrow) \quad R + F = W, \quad F = W - R = \frac{W}{9}$$

$$F \leq \mu N \Rightarrow \frac{W}{9} \leq \mu \frac{W}{3}, \quad \mu \geq \frac{1}{3}.$$

c

The ladder has negligible thickness / the ladder does not bend.

Solutionbank M2

Edexcel AS and A Level Modular Mathematics

Exercise E, Question 11

Question:

A uniform pole AB of mass 40 kg and length 3 m , is smoothly hinged to a vertical wall at one end A . The pole is held in equilibrium in a horizontal position by a light rod CD . One end C of the rod is fixed to the wall vertically below A . The other end D is freely jointed to the pole so that $\angle ACD = 45^\circ$ and $AC = 1\text{ m}$, as shown in the diagram. Find

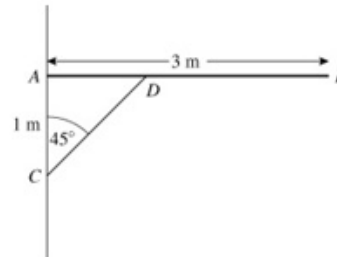

- the thrust in the rod CD ,
- the magnitude of the force exerted by the wall on the pole at A .

The rod CD is removed and replaced by a longer light rod CM , where M is the midpoint of AB . The rod is freely jointed to the pole at M . The pole AB remains in equilibrium in a horizontal position.

- Show that the force exerted by the wall on the pole at A now acts horizontally.

Solution:

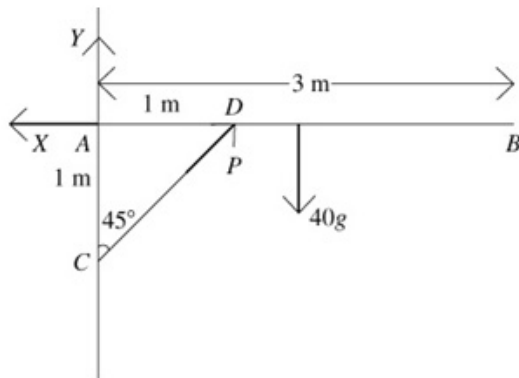

Let the horizontal and vertical components of the force at A be X and Y respectively. Let the thrust in the rod be P .

a

$$M(A) \quad 1 \times P \times \cos 45^\circ = 40g \times \frac{3}{2}$$

$$P = \frac{60g}{\cos 45^\circ} = 60\sqrt{2}g = 830\text{ N (2 s.f.)}$$

b

$$R(\rightarrow) \quad X = P \cos 45^\circ = 60g$$

$$R(\uparrow) \quad Y + P \cos 45^\circ = 40g$$

$$Y = 40g - 60g = -20g$$

$$\text{resultant} = \sqrt{X^2 + Y^2} = 10g\sqrt{4^2 + 2^2} = 10g\sqrt{40} = 620\text{ N (2 s.f.)}$$

c

The lines of action of P and the weight meet at M , hence the line of action of the resultant of X and Y must also pass through M (3 forces acting on a body in equilibrium). Therefore the reaction must act horizontally (i.e. no vertical component).

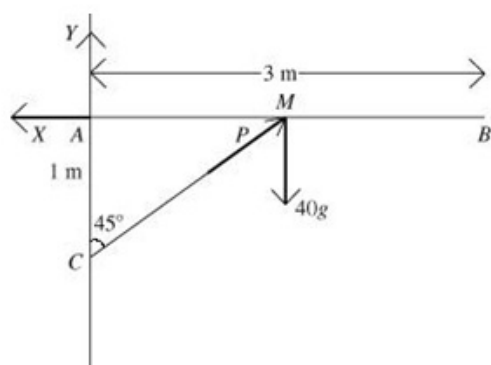

Solutionbank M2

Edexcel AS and A Level Modular Mathematics

Exercise E, Question 12

Question:

A uniform rod AB , of weight W and length $2a$, is used to display a light banner. The rod is freely hinged to a vertical wall at point B . It is held in a horizontal position by a light wire attached to A and to a point C vertically above B on the wall. The angle CAB is θ ,

where $\tan \theta = \frac{1}{3}$.

- a Show that the tension in the wire is

$$\frac{W}{2 \sin \theta}$$

- b Find, in terms of W , the magnitude of the force exerted by the wall on the rod at B .

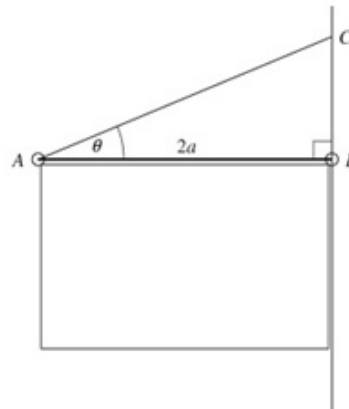

Solution:

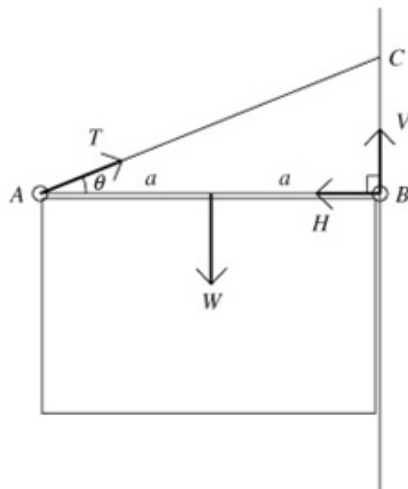

T is the tension in the string, V and H are horizontal and vertical components of the force at B .

a

$$\begin{aligned} \text{M}(B) \quad a \times W &= T \sin \theta \times 2a \\ \Rightarrow T &= \frac{W}{2 \sin \theta} \end{aligned}$$

b

$$\begin{aligned} \text{R}(\rightarrow) \quad T \cos \theta &= H \\ &= \frac{W}{2 \sin \theta} \times \cos \theta = \frac{W}{2 \tan \theta} = \frac{3W}{2} \end{aligned}$$

$$\text{R}(\uparrow) \quad T \sin \theta + V = W = \frac{W}{2} + V \Rightarrow V = \frac{W}{2}$$

so, using Pythagoras, the magnitude of the resultant force is

$$\frac{W}{2} \sqrt{1^2 + 3^2} = \frac{\sqrt{10}W}{2}$$

Solutionbank M2

Edexcel AS and A Level Modular Mathematics

Exercise E, Question 13

Question:

A uniform ladder, of weight W and length 5 m, has one end on rough horizontal ground and the other touching a smooth vertical wall. The coefficient of friction between the ladder and the ground is 0.3.

Given that the top of the ladder touches the wall at a point 4 m vertically above the level of the ground,

a show that the ladder can not rest in equilibrium in this position.

In order to enable the ladder to rest in equilibrium in the position described above, a brick is attached to the bottom of the ladder.

Assuming that this brick is at the lowest point of the ladder, but not touching the ground,

b show that the horizontal frictional force exerted by the ladder on the ground is independent of the mass of the brick,

c find, in terms of W and g , the smallest mass of the brick for which the ladder will rest in equilibrium.

Solution:

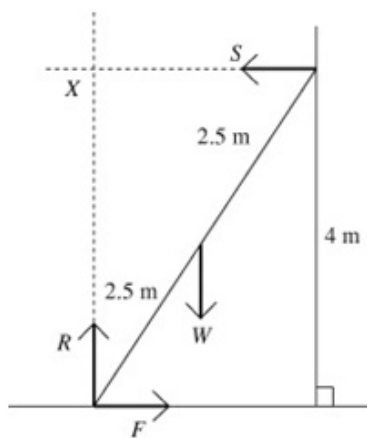
**a**

$$R(\uparrow) F = S, R(\rightarrow) R = W$$

$$M(X) 1.5W = 4F$$

$$F \leq \mu R \Rightarrow \frac{1.5W}{4} \leq 0.3 \times R$$

$$\frac{3W}{8} \leq \frac{3W}{10} \Rightarrow \frac{3}{8} \leq \frac{3}{10},$$

which is false, therefore the assumption $F \leq \mu R$ must be false – the ladder can not be resting in equilibrium.

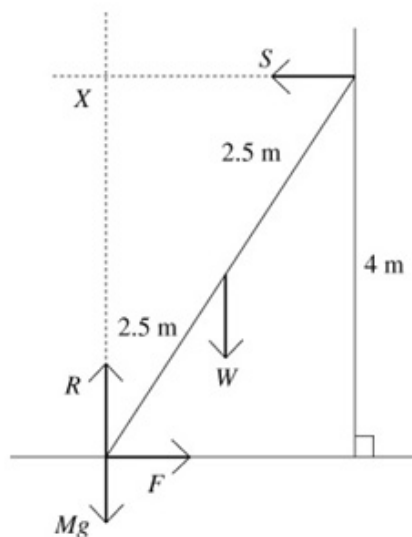
**b**

With the brick in place (second diagram).

$$M(X) 1.5W = 4F \text{ so}$$

$$F = \frac{1.5W}{4} = \frac{3W}{8}, \text{ which is independent of}$$

M , the mass of the brick.

$$R(\uparrow) R = W + Mg, R(\rightarrow) F = S$$

$$F \leq \mu R \Rightarrow \frac{3W}{8} \leq 0.3(W + Mg) = \frac{3(W + Mg)}{10}$$

$$\Rightarrow 10W \leq 8W + 8Mg$$

$$8Mg \geq 2W, M \geq \frac{W}{4g}$$

So the smallest value for M is $\frac{W}{4g}$.

Solutionbank M2

Edexcel AS and A Level Modular Mathematics

Exercise E, Question 14

Question:

A uniform drawbridge $ABCD$ is 6 m long and has mass 1200 kg. The bridge is held at 10° to the horizontal by two chains attached to points G and H on the bridge 5 m from the hinge and to fixed points E and F at a height of 7 m vertically above A and D . Find the force from the hinge.

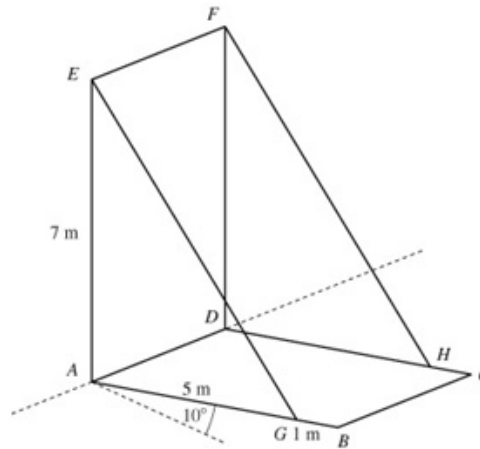

Solution:

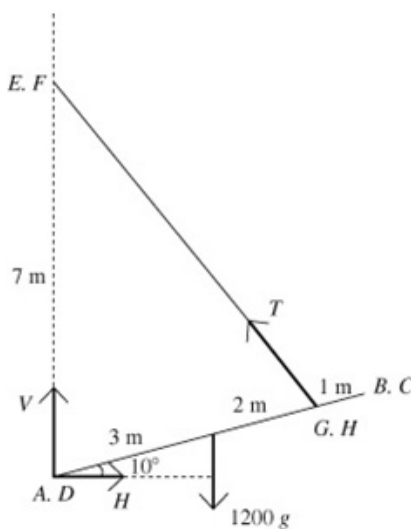

V and H are the vertical and horizontal components of the force at the hinge.
 T is the tension in the cables.

We have 2 unknown forces, V and H , that we need to find. T is unknown, but we are not asked to find it. If we take moments about axes EF and GH then we can obtain 2 equations in V and H but not T .

About EF :

$$7H = 1200g \times 3 \cos 10^\circ,$$

$$H = \frac{3600g \cos 10^\circ}{7} \approx 4960 \text{ N}$$

About GH :

$$V \times 5 \cos 10^\circ = H \times 5 \sin 10^\circ + 1200g \times 2 \cos 10^\circ$$

$$\Rightarrow V = \frac{5H \sin 10^\circ + 2400g \cos 10^\circ}{5 \cos 10^\circ} \approx 5580 \text{ N}$$

Combining the two components of the force at the hinge gives a force of magnitude

$$\sqrt{4960^2 + 5580^2} \approx 7470 \text{ N at an angle of}$$

$$\tan^{-1} \frac{5580}{4960} \approx 48^\circ \text{ to the horizontal.}$$