



Pearson
Edexcel

Mark Scheme (Results)

Summer 2022

**Pearson Edexcel International Advanced Level
In Decision Mathematics (WDM11) Paper 01**

Edexcel and BTEC Qualifications

Edexcel and BTEC qualifications are awarded by Pearson, the UK's largest awarding body. We provide a wide range of qualifications including academic, vocational, occupational and specific programmes for employers. For further information visit our qualifications websites at www.edexcel.com or www.btec.co.uk. Alternatively, you can get in touch with us using the details on our contact us page at www.edexcel.com/contactus.

Pearson: helping people progress, everywhere

Pearson aspires to be the world's leading learning company. Our aim is to help everyone progress in their lives through education. We believe in every kind of learning, for all kinds of people, wherever they are in the world. We've been involved in education for over 150 years, and by working across 70 countries, in 100 languages, we have built an international reputation for our commitment to high standards and raising achievement through innovation in education. Find out more about how we can help you and your students at: www.pearson.com/uk

Summer 2022

Question Paper Log number P72458A

Publications Code WDM11_01_2206_MS

All the material in this publication is copyright

© Pearson Education Ltd 2022

General Marking Guidance

- All candidates must receive the same treatment. Examiners must mark the first candidate in exactly the same way as they mark the last.
- Mark schemes should be applied positively. Candidates must be rewarded for what they have shown they can do rather than penalised for omissions.
- Examiners should mark according to the mark scheme not according to their perception of where the grade boundaries may lie.
- There is no ceiling on achievement. All marks on the mark scheme should be used appropriately.
- All the marks on the mark scheme are designed to be awarded. Examiners should always award full marks if deserved, i.e. if the answer matches the mark scheme. Examiners should also be prepared to award zero marks if the candidate's response is not worthy of credit according to the mark scheme.
- Where some judgement is required, mark schemes will provide the principles by which marks will be awarded and exemplification may be limited.
- Crossed out work should be marked UNLESS the candidate has replaced it with an alternative response.

PEARSON EDEXCEL IAL MATHEMATICS

General Instructions for Marking

1. The total number of marks for the paper is 75.
2. The Edexcel Mathematics mark schemes use the following types of marks:

'M' marks

These are marks given for a correct method or an attempt at a correct method. In Mechanics they are usually awarded for the application of some mechanical principle to produce an equation.

e.g. resolving in a particular direction, taking moments about a point, applying a suvat equation, applying the conservation of momentum principle etc.

The following criteria are usually applied to the equation.

To earn the M mark, the equation

(i) should have the correct number of terms

(ii) be dimensionally correct i.e. all the terms need to be dimensionally correct

e.g. in a moments equation, every term must be a 'force x distance' term or 'mass x distance', if we allow them to cancel 'g' s.

For a resolution, all terms that need to be resolved (multiplied by sin or cos) must be resolved to earn the M mark.

M marks are sometimes dependent (DM) on previous M marks having been earned.

e.g. when two simultaneous equations have been set up by, for example, resolving in two directions and there is then an M mark for solving the equations to find a particular quantity – this M mark is often dependent on the two previous M marks having been earned.

'A' marks

These are dependent accuracy (or sometimes answer) marks and can only be awarded if the previous M mark has been earned. E.g. M0 A1 is impossible.

'B' marks

These are independent accuracy marks where there is no method (e.g. often given for a comment or for a graph)

A few of the A and B marks may be f.t. – follow through – marks.

3. General Abbreviations

These are some of the traditional marking abbreviations that will appear in the mark schemes.

- bod – benefit of doubt
 - ft – follow through
 - the symbol \surd will be used for correct ft
 - cao – correct answer only
 - cso - correct solution only. There must be no errors in this part of the question to obtain this mark
 - isw – ignore subsequent working
 - awrt – answers which round to
 - SC: special case
 - oe – or equivalent (and appropriate)
 - dep – dependent
 - indep – independent
 - dp decimal places
 - sf significant figures
 - * The answer is printed on the paper
 - \square The second mark is dependent on gaining the first mark
4. All A marks are 'correct answer only' (cao.), unless shown, for example, as A1 ft to indicate that previous wrong working is to be followed through. After a misread however, the subsequent A marks affected are treated as A ft, but manifestly absurd answers should never be awarded A marks.
 5. For misreading which does not alter the character of a question or materially simplify it, deduct two from any A or B marks gained, in that part of the question affected.
 6. If a candidate makes more than one attempt at any question:
 - If all but one attempt is crossed out, mark the attempt which is NOT crossed out.
 - If either all attempts are crossed out or none are crossed out, mark all the attempts and score the highest single attempt.
 7. Ignore wrong working or incorrect statements following a correct answer.

Question Number	Scheme	Marks																																																																						
1.(a)	$\frac{1150}{300} = 3.83\dots$ so lower bound is 4	M1 A1 (2)																																																																						
(b)	<table border="1"> <tbody> <tr><td>175</td><td>135</td><td>210</td><td>105</td><td>100</td><td>150</td><td>60</td><td>20</td><td>70</td><td>125</td></tr> <tr><td>175</td><td>210</td><td>135</td><td>105</td><td>150</td><td>100</td><td>60</td><td>70</td><td>125</td><td>20</td></tr> <tr><td>210</td><td>175</td><td>135</td><td>150</td><td>105</td><td>100</td><td>70</td><td>125</td><td>60</td><td>20</td></tr> <tr><td>210</td><td>175</td><td>150</td><td>135</td><td>105</td><td>100</td><td>125</td><td>70</td><td>60</td><td>20</td></tr> <tr><td>210</td><td>175</td><td>150</td><td>135</td><td>105</td><td>125</td><td>100</td><td>70</td><td>60</td><td>20</td></tr> <tr><td>210</td><td>175</td><td>150</td><td>135</td><td>125</td><td>105</td><td>100</td><td>70</td><td>60</td><td>20</td></tr> <tr><td>210</td><td>175</td><td>150</td><td>135</td><td>125</td><td>105</td><td>100</td><td>70</td><td>60</td><td>20</td></tr> </tbody> </table>	175	135	210	105	100	150	60	20	70	125	175	210	135	105	150	100	60	70	125	20	210	175	135	150	105	100	70	125	60	20	210	175	150	135	105	100	125	70	60	20	210	175	150	135	105	125	100	70	60	20	210	175	150	135	125	105	100	70	60	20	210	175	150	135	125	105	100	70	60	20	M1 A1 A1ft A1cso (4)
175	135	210	105	100	150	60	20	70	125																																																															
175	210	135	105	150	100	60	70	125	20																																																															
210	175	135	150	105	100	70	125	60	20																																																															
210	175	150	135	105	100	125	70	60	20																																																															
210	175	150	135	105	125	100	70	60	20																																																															
210	175	150	135	125	105	100	70	60	20																																																															
210	175	150	135	125	105	100	70	60	20																																																															
(c)	Truck 1: 210 <u>70</u> 20 Truck 2: 175 <u>125</u> Truck 3: 150 135 Truck 4: <u>105</u> <u>100</u> 60	M1 <u>A1</u> A1 (3)																																																																						
		9 marks																																																																						

Notes for Question 1

a1M1: Attempt to find the lower bound $(1150 \pm 210) / 300$ (a value of 3.83 (or better) seen with no working can imply this mark)

a1A1: Correct calculation seen **or** 3.83 (or better) followed by a lower bound of 4. An answer of 4 with no working scores M0A0. **Only** seeing 3.8 followed by 4 scores M1A0

b1M1: Bubble sort. Consistent direction, end number (20) in place and the list beginning with the correct first five numbers (175 210 135 105 150). Do check these carefully as some candidates show the result of each comparison and swap in their first pass. Consider the placement of the candidate's numbers, rather than what the candidate labels each line of their pass. For example, assume that the first time that the 20 appears at the end of the list is the end of their first pass

b1A1: The first, second **and** third passes correct – so end three numbers in place

b2A1ft: Fourth and fifth passes correct following through from the candidate's third pass – so end five numbers in place

b3A1: cso (correct solution only – so previous three marks must have been awarded in this part). Must show a 6th pass showing no swaps/changes (give bod if the passes are not labelled but do not award this mark if it is clear that after the 5th pass the list is simply being written out again (rather than a genuine 6th pass taking place)). Condone if the sort continues until a 9th pass has been completed (but there should be no changes in the 9th pass)

SC in (b) if list is sorted into ascending order (regardless of reversing at the end of the sort) award M1 for 135 175 105 100 150 60 20 70 125 210 and then

A1 for 135 105 100 150 60 20 70 125 175 210 **and** 105 100 135 60 20 70 125 135 175 210 so 2 marks max.

c1M1: **Their** first four items placed correctly and at least eight values placed in trucks (if correct this will be the bold items but must check **their** packing if any of **their** first four values are incorrect – note that the maximum weight is 300). Condone cumulative totals for M1 only. First-fit increasing scores no marks in this part. If no sort seen in (b) then mark (c) assuming the correct ordered list in descending order

c1A1: First eight items placed correctly (the underlined and bold values). No additional or repeated values. No follow through or misreads for the A marks in this part. Must be using the correct ten values (so **any** wrong values regardless of where they appear in the trucks is A0)

c2A1: cso. No additional or repeated values

2.(a)	$x = 10$ $y = 7$ from $9 - 0 - 5 = 2(22 - 13 - y)$ (oe)	B1 B1 (2)
-------	--	------------------------

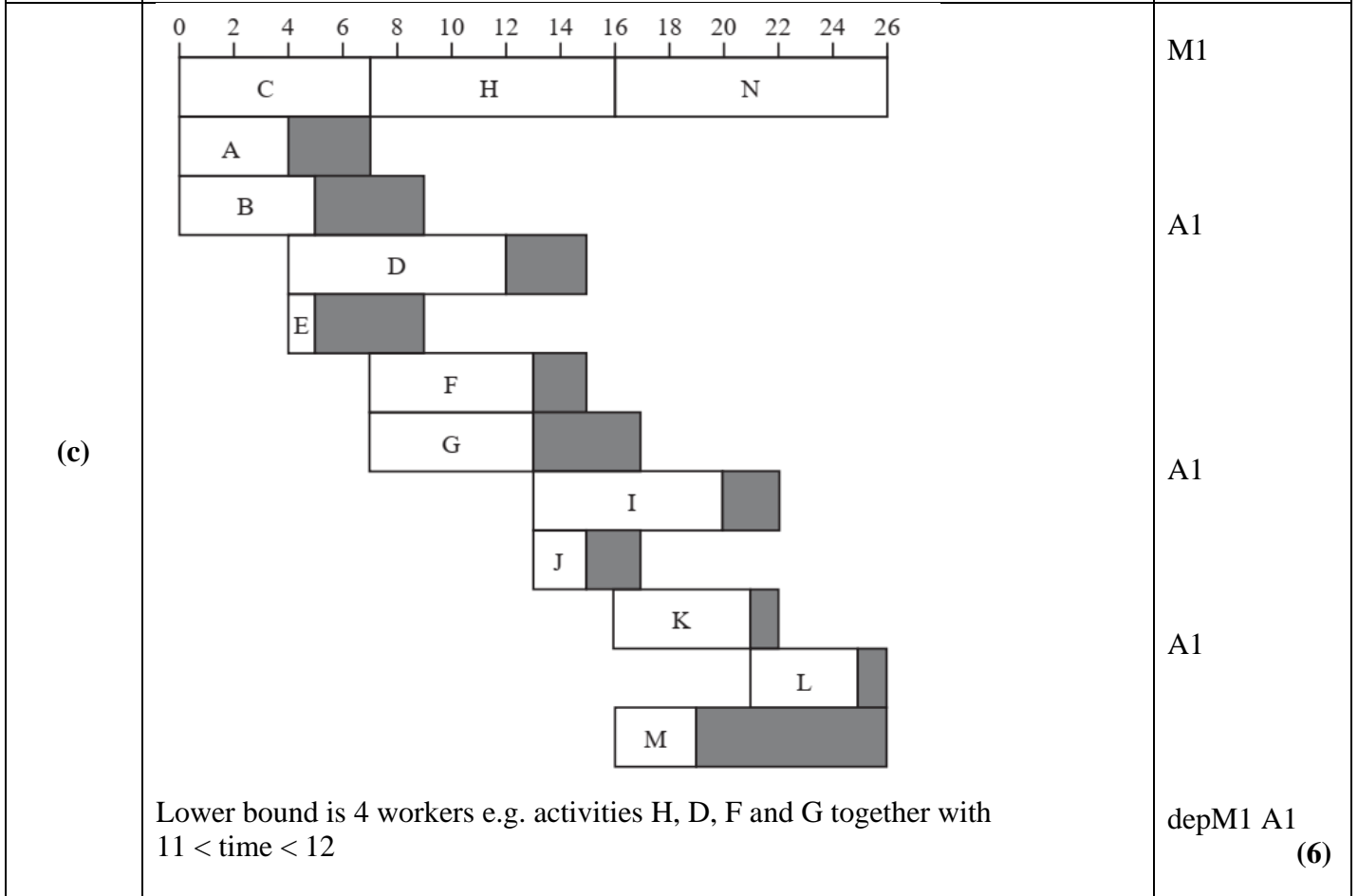
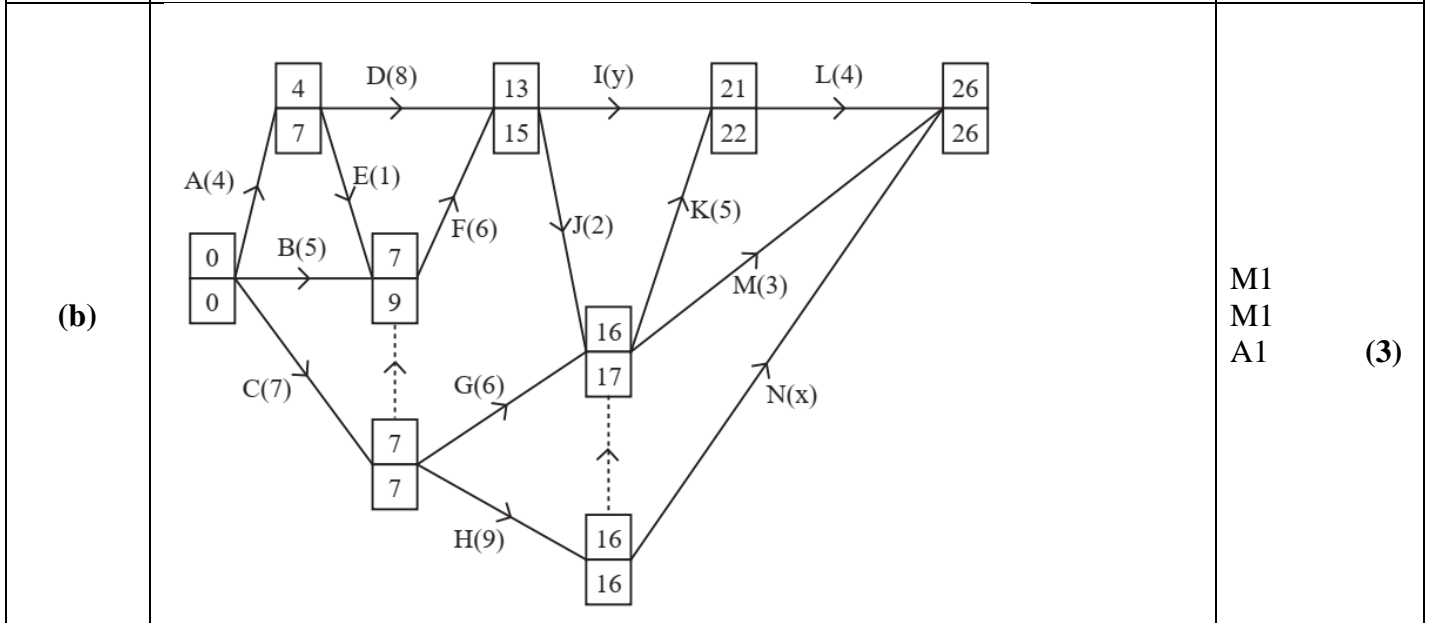

		M1 A1 A1 A1 depM1 A1 (6)
--	--	--

Notes for Question 2

a1B1: cao for x (ignore working for this mark)

a2B1: cao with sufficient working as Answer Given – as a minimum accept $4 = 2(9 - y)$ (oe) but just $4 = 18 - 2y$ is B0

b1M1: All top boxes complete, values generally increasing in the direction of the arrows (so generally going from ‘left to right’ across the network), condone one ‘rogue’ value (if values do not increase in the direction of the arrows then if one value is ignored and the remaining values do increase in the direction of the arrows then this is considered to be a single rogue value). Note that all values in the top boxes could be incorrect but it can still score the M mark if the values are **increasing** in the way stated above

b2M1: All bottom boxes complete. Values generally decreasing in the opposite direction of the arrows (so generally going from ‘right to left’ across the network), condone one ‘rogue’ (as described above in **b1M1**)

b1A1: cao – **all** values correct

c1M1: At least ten different activities labelled including at least seven floats. A scheduling diagram (so a diagram in which no floats are evident) scores M0

c1A1: The critical activities dealt with correctly and appearing just once (C, H and N) and three non-critical activities dealt with correctly (both duration and total float correct)

c2A1: Any six non-critical activities correct (this mark is not dependent on the previous A mark)

c3A1: cso – completely correct Gantt chart (exactly fourteen activities appearing just once)

c2dM1: Dependent on first M mark in this part. Either a statement with the correct number of workers (4) and stating the correct activities (H, D, F and G) with any numerical time stated **or** the correct number of workers (4) and a time in the interval $11 < t < 12$ – mark the numerical value only not their use of the words ‘day/time’ (or equivalent)

c4A1: A completely correct statement with details of both time **and** activities. Candidates must give a time within the correct interval of $11 < t < 12$, e.g. 11.5 (or ‘on/during day 12’) and state the correct activities (H, D, F and G).

Please note the strict inequalities for the time interval (e.g. implying a time of 11 is incorrect). Answers given as an interval of time are acceptable provided the time interval stated is correct for all its possible values (e.g. time 11 – 12 or ‘between 11 and 12’ is A0). A completely correct statement with an additional incorrect statement scores A0 (so do not ignore subsequent working)

For (c) the following may be useful in checking their cascade chart provided the float is shown after the corresponding activity:

Activity	Duration + Float	Activity	Duration + Float	Activity	Duration + Float
A	0 to 4 F: 4 to 7	F	7 to 13 F: 13 to 15	K	16 to 21 F: 21 to 22
B	0 to 5 F: 5 to 9	G	7 to 13 F: 13 to 17	L	21 to 25 F: 25 to 26
C	0 to 7 Critical	H	7 to 16 Critical	M	16 to 19 F: 19 to 26
D	4 to 12 F: 12 to 15	I	13 to 20 F: 20 to 22	N	16 to 26 Critical
E	4 to 5 F: 5 to 9	J	13 to 15 F: 15 to 17		

3.(a)	Kruskal: AB(6), BP(10), CW(11), CP(12), HM(14), AH(15), reject CH(17), reject AC(18), reject AP(20), reject MW(21), LY(21), AS(26), LS(28) (not BS, LM, HL, SY, AL)	M1 A1 A1 (3)
(b)	Prim: AB, BP, CP, CW, AH, HM, AS, LS, LY	M1 A1 A1 (3)
(c)	143 (miles)	B1 (1)
(d)	286 (miles)	B1ft (1)
(e)	NNA starting at W: W – C – P – B – A – H – M – L – Y – S – W $11 + 12 + 10 + 6 + 15 + 14 + 40 + 21 + 48 + 55 = 232$	M1 A1 (2)
(f)	The best upper bound is the one starting at Y as 212 is less than both 232 and 286	B1 (1)
(g)	$(143 - 11) + 11 + 21 = 164$ (miles)	M1 A1 (2)
(h)	WCPBAHMLYSACW	B1 (1)
		14 marks

Notes for Question 3

a1M1: First four arcs (AB, BP, CW, CP) correctly chosen and at least one rejection seen at some point
a1A1: All arcs in tree selected correctly and in the correct order (AB, BP, CW, CP, HM, AH, LY, AS, LS) – no other arcs in MST
a2A1: cso including all rejections correct and at the correct time – **note that LY can be accepted before MW is rejected.** We do not need to see the explicit rejection of arcs BS to AL but if these are explicitly rejected then they must be in the correct order. Note that a list of all the arcs in the correct order followed by a list of the arcs in the MST can score full marks
b1M1: First three arcs correctly chosen in order (AB, BP, CP,...) **or** first four nodes {A, B, P, C, ...} correctly chosen in order. If any **explicit** rejections seen at some point then M1 (max) only. Order of nodes may be seen at the top of a matrix/table {1, 2, 4, -, -, -, 3, -, -, -} so do check carefully for this. Starting at any other node can score M1 only for first three arcs chosen correctly
b1A1: First six arcs correctly chosen in order (AB, BP, CP, CW, AH, HM,...) **or** all ten nodes {A, B, P, C, W, H, M, S, L, Y} correctly chosen in order. Order of nodes may be seen at the top of a matrix so for the first two marks accept {1, 2, 4, 6, 9, 7, 3, 8, 5, 10} (**no** missing numbers)
b2A1: cso – all **arcs** correctly **stated** and chosen in the correct order (with no additional arcs). They must be considering arcs for this final mark (do not accept a list of nodes or numbers across the top of the matrix unless the correct list of arcs (in the correct order) is also seen)
c1B1: cao (143) – this mark can be awarded if seen in (b) (although if answered in (c) too then mark according to the answer given in (c))
d1B1ft: Follow through double their answer from (c)
e1M1: Nearest neighbour route starting at W – must have at least W – C – P – B – A – H – ... allow if stated in terms of arcs
e1A1: CAO on length (232) **and** route (must return to W and can be stated in terms of arcs)
f1B1: An indication that 212 is the minimum (of 212 and the answers to (d) and (e)) – this mark is dependent on the correct values in (d) and (e) so accept an answer of the form ‘the one starting at Y (or the route with weight 212) as it is the least’ – we do not need to see explicit mention of the values in (d) and (e) provided they are correct in (d) and (e)
g1M1: (weight of their MST from (c) **or** (b) **or** 132 **only**) – $11 + 11(WC) + 21(MW)$ (oe so may not see the $-11 + 11$). A correct answer of 164 can imply this (and the next) mark
g1A1: 164
h1B1: cao – either the route must be written out in full (in terms of nodes or arcs) **or** they must make it absolutely clear that the route begins exactly as in (e) (which must therefore be correct) but after S, towns A and C are visited before (returning to) W. Just stating that A, C, W are visited twice (or similar) is B0

4.(a)(i)	$z = 14 - 2x - y$ substituted into both $x + 2y + z \leq 15$ and $3x - 4y + 2z \leq 1$	M1
	$-x + y \leq 1$	A1
	$x + 6y \leq 27$	A1
(a)(ii)	The maximum possible value of P is 1	A1 (4)
(b)(i)	$-x + y = 1$ & $x + 6(1 + x) \leq 27$	M1
	$7x \leq 21$ & maximum possible value of x is 3	A1
(b)(ii)	$x = 3, y = 4$ and $z = 4$	A1 (3)
		7 marks

Notes for Question 4

Mark parts (a) and (b) together (so ignore labelling of parts in this question)

ai1M1: substituting $z = 14 - 2x - y$ into **both** correct inequality constraints – allow sign errors in re-arranging to make z the subject. This mark can also be awarded for **one** correct simplified inequality

ai1A1: cao ($-x + y \leq 1$) – or equivalent (e.g. $x - y + 1 \leq 0$) but must be three terms only – ISW if candidates incorrectly re-arrange after a correct three term inequality seen

ai2A1: cao ($x + 6y \leq 27$) – or equivalent but must be three terms only – ISW if candidates incorrectly re-arrange after a correct three term inequality seen

aii3A1: cao - this mark can be awarded after correctly finding x and y – note that this mark is not dependent on the previous A mark. Just stating $P = 1$ is fine (so do not need to mention ‘maximum’)

bi1M1: substitute their $-x + y = 1$ into their $x + 6y \leq 27$ or their $x + 6y = 27$

bi1A1: correct value of x (if using equations then they do not need to justify that this is the maximum value)

bii2A1: cao for x, y **and** z – accept if seen as a coordinate

5. (a)	<p>e.g.</p>	M1 A1 A1 A1 A1 (5)
--------	-------------	--------------------------------

(b)(i)	24 (hours)	B1
(b)(ii)	C, F, I and J	B1
(b)(iii)	Total float for G is 3 (hours) Total float for K is 1 (hour)	B1 B1 (4)
		9 marks

Notes for Question 5

Condone lack of, or incorrect, numbered events throughout. ‘Dealt with correctly’ means that the activity starts from the correct event but need not necessarily finish at the correct event, e.g. ‘D dealt with correctly’ requires the correct precedences for this activity, i.e. A and B labelled correctly and leading into the same node and D starting from that node but do not consider the end event for D. **Activity on node is M0**

If an arc is not labelled, for example, if the arc for activity C is not labelled (but the arc is present) then this will lose the first A mark and the final (CSO) A mark – they can still earn the second A mark on the bod. If two or more arcs are not labelled then mark according to the scheme. Assume that a solid line is an activity which has not been labelled rather than a dummy (even if in the correct place for where a dummy should be)

Ignore incorrect or lack of arrows on the activities for the first four marks only

- a1M1:** At least eight activities (labelled on arc), one start and at least two dummies placed
- a1A1:** Activities A, B, C **and** two of activities D, E, F or G dealt with correctly (so at least one dummy (+ correct arrow) required)
- a2A1:** Activities D, E, F and G dealt with correctly – so first two dummies (+ correct arrows) are required for this mark
- a3A1:** Activities H and I dealt with correctly (so must have the final two dummies + correct arrows)
- a4A1:** cso – activities J and K dealt with correctly. All arrows correctly placed for each activity with one finish and at most four dummies. Note that some candidates are drawing the graph non-planar which is fine

Please check all arcs carefully for arrows – if there are no arrows on any dummies then M1 only. Note that additional (but unnecessary) ‘correct’ dummies that still maintain precedence for the network should only be penalised with the final A mark if earned

- bi1B1:** cao (24)
- bii1B1:** cao (C, F, I and J with no others)
- biii1B1:** cao (total float for G as 3)

biii2B1: cao (total float for K as 1)

Useful for checking (a):

Activity	A	B	C	D	E	F	G	H	I	J	K
IPA	-	-	-	A, B	A, B	B, C	B, C	D	D, E, F, G	H, I	D, E, F

<p>6.(a)</p>	<p>Fastest time: 71 (minutes) Quickest route: ADCBGH</p>	<p>M1 A1 (DCB) A1 (FE) A1ft (GH)</p> <p>A1ft A1</p> <p>(6)</p>
<p>(b)</p>	<p>$AD + EH = 12 + 21 = 33^*$</p>	<p>M1 A1</p>
	<p>$A(DCB)E + D(CBG)H = 52 + 59 = 111$</p>	<p>A1</p>
	<p>$A(DCBG)H + D(CB)E = 71 + 40 = 111$</p>	<p>A1</p>
	<p>$(383 + x) + 33 \dots 440 \text{ } x \dots\dots$</p>	<p>depM1</p>
	<p>$24, \dots, x < 30$</p>	<p>A1 (6)</p>
<p>(c)</p>	<p>e.g. ABCEBGCDADDFJGHEHFCA</p>	<p>B1 (1)</p>
<p>(d)</p>	<p>If a direct road DH opens then only A and E are odd therefore the shortest inspection route is $(383 + x) + 25 (DH) + 52 (AE)$</p>	<p>M1</p>
	<p>$460 + x = 488$ therefore $x = 28$</p>	<p>A1 (2)</p>
<p>Notes for Question 6</p>		

In (a) it is important that all values at each node are checked very carefully – the order of the working values must be correct for the corresponding A mark to be awarded e.g. at H the working values must be 74 73 71 in that order (so 74 71 73 is incorrect)

It is also important that the order of labelling is checked carefully. The order of labelling must be a strictly increasing sequence – so 1, 2, 3, 3, 4, ... will be penalised once (see notes below) but 1, 2, 3, 5, 6, ... is fine. Errors in the final values and working values are penalised before errors in the order of labelling

a1M1: A larger value replaced by a smaller value at least twice in the working values at either B, C, E, F, G, H

a1A1: All values at D, C and B correct and the working values in the correct order

a2A1: All values at F and E correct and the working values in the correct order

a3A1ft: All values in G and H correct on the follow through and the working values in the correct order. To follow through G check that the working values at G follow from the candidate's final values for the nodes that are directly attached to G (which are C and B). For example, **if** correct then the order of labelling of nodes C and B are 3 and 4 respectively so the working values at G should come from C and B in that order. The first working value at G should be their 23 (the Final value at C) + 43 (the weight of the arc CG), the second working value at G should be their 31 (the Final value at B) + 30 (the weight of the arc BG). Repeat the process for H (which will have working values from F, E and G with the order of these nodes determined by the candidate's order of labelling at F, E and G)

a4A1ft: Follow through their final value at H **only** – if answer is 71 but this is not the Final Value at H then A0

a5A1: CAO (ADCBGH)

b1M1: Three distinct pairings of the nodes A, D, E and H

b1A1: Any one row correct including pairing **and** total

b2A1: Any two rows correct including pairings **and** totals

b3A1: All three rows correct including pairings **and** totals

b2dM1: $(383 + x) + (\text{their least pairing total})$ with any inequality sign or equal to 440 – dependent on first M mark in (b). Give bod if not all totals are shown (so if they only give two totals then they should be using the least of these two) but they must have shown all three distinct pairings of the four odd nodes

b4A1: cao (24,, $x < 30$) – condone 24,, x ,, 29

c1B1: cao (check: starting and finishing at A, 19 nodes, AD and EH repeated in route, with A(3), B(2), C(3), D(2), E(2), F(2), G(2), H(2), J(1)) – can be given in terms of arcs

d1M1: $(383 + x) + 25 + \text{their } 52$ (where 'their 52' must be the length of their shortest path from A to E in either (a) **or** (b) **or** they state/imply the shortest path from A to E is 52) - a correct value of 28 with no working can imply this mark only

d1A1: cao (28) from correct working **and** correct reasoning that A and E are the only odd nodes **or** that we only need to pair A and E (as a minimum accept mention of A and E only but ignore any mention of the new direct road from D to H)

7.(a)(i)	Let the point of intersection of $-x + 5y = 10$ and the unknown line be $A(a_1, a_2)$ Let the point of intersection of $4x + 8y = 65$ and the unknown line be $B(b_1, b_2)$	
	$a_1 + 3a_2 = 10$ or $b_1 + 3b_2 = 24$ $- a_1 + 5a_2 = 10$ $4b_1 + 8b_2 = 65$	M1 A1
	$A\left(\frac{5}{2}, \frac{5}{2}\right)$ or $B\left(\frac{3}{4}, \frac{31}{4}\right)$	A1
	$a_1 + 3a_2 = 10$ and $b_1 + 3b_2 = 24$ $- a_1 + 5a_2 = 10$ $4b_1 + 8b_2 = 65$	depM1
	$A\left(\frac{5}{2}, \frac{5}{2}\right)$ and $B\left(\frac{3}{4}, \frac{31}{4}\right)$	A1
(ii)	$y - \frac{5}{2} = \frac{\frac{31}{4} - \frac{5}{2}}{\frac{3}{5} - \frac{2}{2}}x - \frac{5}{2}$ ($y = -3x + 10$)	ddM1
	$3x + y \dots 10$	A1
	$-x + 5y \dots 10, 4x + 8y \dots 65$	B1 (8)
(b)	$k = \frac{15/4}{35/4} = \frac{3}{7}$	M1 A1 (2)
		10 marks

Notes for Question 7

ai1M1: Form simultaneous equations to find one of the points of intersection of the unknown line with one of the given lines – allow sign slips only

ai1A1: One correct pair of simultaneous equations (allow any choice of letters for their coordinates)

ai2A1: One correct point (need not be stated as coordinates so $x = \dots, y = \dots$ is fine)

ai2dM1: Forming both pairs of simultaneous equations (dependent on previous M mark) – allow sign slips only

ai3A1: Both correct points (need not be stated explicitly as coordinates)

aii3ddM1: Find the correct equation of the third line for **their** A and B (dependent on both previous M marks). Allow unsimplified but must be the correct equation for the line passing through their two points. Condone any inequality sign instead of equals

aii4A1: cao (for the third line) – must be three terms but accept any equivalent form e.g. $6x + 2y - 20 \dots 0$

aii1B1: cao (for the other two given lines) – must be three terms only but accept any equivalent forms

b1M1: Attempt to find the gradient of the line through O and $\left(\frac{35}{4}, \frac{15}{4}\right)$ (condone reciprocal) – ignore use of

inequalities or k for this mark e.g. seeing $\frac{15/4}{35/4}$ **or** $\frac{15}{35}$ **or** $\frac{35}{15}$ etc. scores M1

b1A1: cao – need not be simplified e.g. $k = \frac{15}{35}$ scores both marks. Allow $y \dots \frac{3}{7}x$, or just $\frac{3}{7}$ but not $k \dots \frac{3}{7}$ only. If more than one value of k implied then A0

