

Mark Scheme (Results)

Summer 2016

Pearson Edexcel A Level

Decision Mathematics 1  
(6689/01)

## **Edexcel and BTEC Qualifications**

Edexcel and BTEC qualifications are awarded by Pearson, the UK's largest awarding body. We provide a wide range of qualifications including academic, vocational, occupational and specific programmes for employers. For further information visit our qualifications websites at [www.edexcel.com](http://www.edexcel.com) or [www.btec.co.uk](http://www.btec.co.uk). Alternatively, you can get in touch with us using the details on our contact us page at [www.edexcel.com/contactus](http://www.edexcel.com/contactus).

## **Pearson: helping people progress, everywhere**

Pearson aspires to be the world's leading learning company. Our aim is to help everyone progress in their lives through education. We believe in every kind of learning, for all kinds of people, wherever they are in the world. We've been involved in education for over 150 years, and by working across 70 countries, in 100 languages, we have built an international reputation for our commitment to high standards and raising achievement through innovation in education. Find out more about how we can help you and your students at: [www.pearson.com/uk](http://www.pearson.com/uk)

Summer 2016

Publications Code 6689\_01\_1606\_MS

All the material in this publication is copyright

© Pearson Education Ltd 2016

## General Marking Guidance

- All candidates must receive the same treatment. Examiners must mark the first candidate in exactly the same way as they mark the last.
- Mark schemes should be applied positively. Candidates must be rewarded for what they have shown they can do rather than penalised for omissions.
- Examiners should mark according to the mark scheme not according to their perception of where the grade boundaries may lie.
- There is no ceiling on achievement. All marks on the mark scheme should be used appropriately.
- All the marks on the mark scheme are designed to be awarded. Examiners should always award full marks if deserved, i.e. if the answer matches the mark scheme. Examiners should also be prepared to award zero marks if the candidate's response is not worthy of credit according to the mark scheme.
- Where some judgement is required, mark schemes will provide the principles by which marks will be awarded and exemplification may be limited.
- Crossed out work should be marked UNLESS the candidate has replaced it with an alternative response.

# PEARSON EDEXCEL GCE MATHEMATICS

## General Instructions for Marking

1. The total number of marks for the paper is 75
2. The Edexcel Mathematics mark schemes use the following types of marks:
  - **M** marks: Method marks are awarded for 'knowing a method and attempting to apply it', unless otherwise indicated.
  - **A** marks: Accuracy marks can only be awarded if the relevant method (M) marks have been earned.
  - **B** marks are unconditional accuracy marks (independent of M marks)
  - Marks should not be subdivided.
3. Abbreviations

These are some of the traditional marking abbreviations that will appear in the mark schemes.

- bod – benefit of doubt
  - ft – follow through
  - the symbol  $\checkmark$  will be used for correct ft
  - cao – correct answer only
  - cso - correct solution only. There must be no errors in this part of the question to obtain this mark
  - isw – ignore subsequent working
  - awrt – answers which round to
  - SC: special case
  - oe – or equivalent (and appropriate)
  - d... or dep – dependent
  - indep – independent
  - dp decimal places
  - sf significant figures
  - \* The answer is printed on the paper or ag- answer given
  - $\square$  or d... The second mark is dependent on gaining the first mark
4. All A marks are 'correct answer only' (cao.), unless shown, for example, as A1 ft to indicate that previous wrong working is to be followed through. After a misread however, the subsequent A marks affected are treated as A ft, but manifestly absurd answers should never be awarded A marks.

5. For misreading which does not alter the character of a question or materially simplify it, deduct two from any A or B marks gained, in that part of the question affected.
6. If a candidate makes more than one attempt at any question:
  - If all but one attempt is crossed out, mark the attempt which is NOT crossed out.
  - If either all attempts are crossed out or none are crossed out, mark all the attempts and score the highest single attempt.
7. Ignore wrong working or incorrect statements following a correct answer.

Question Number	Scheme	Marks
1. (a)	A bipartite graph consists of two sets of vertices X and Y The edges only join vertices in X to vertices in Y, not vertices within a set	B1 B1 (2)
(b)	Alternating path: $P - A = N - E = T - D = L - C = M - B$ Change status: $P = A - N = E - T = D - L = C - M = B$ Complete matching: $L = C, M = B, N = E, P = A, T = D$	M1 A1 A1 (3) <b>5 marks</b>

### Notes for Question 1

a1B1: **Two sets of vertices** – must contain the three words in bold – accept nodes for vertices but not points or any other non-technical language

a2B1: (Edges) must go from one (set) into the other – candidates must give an indication of going from one set to the other – however, they do not need to use the word ‘set’ for this mark. Candidates do not need to mention that edges should not join vertices within a set but if a candidate does imply that a bipartite graph can join vertices within a set then withhold this mark (**no isw**). As an absolute minimum accept a statement along the lines of: ‘must go from one to the other’ – note that for this mark technical language may be absent or incorrect

b1M1: An alternating path (e.g. letter 1<sup>st</sup> set – letter 2<sup>nd</sup> set – letter 1<sup>st</sup> set – ...) from P to B or vice – versa

b1A1: CAO – a correct path including change status **either** stated (only accept ‘change (of) status’ **or** ‘c.s.’ but not, e.g. ‘change state’) **or** shown (all symbols e.g. (... – ... = ... – ...) interchanged (... = .... – ... = ...))  
Chosen path clear

e.g.

- $P * A = N * E = T * D = L * C = M * B$   
 $P = A * N = E * T = D * L = C * M = B$ 
scores M1A1 (change status shown)
- change status  $P = A - N = E - T = D - L = C - M = B$ 
scores M1A1 (change status stated)
- c.s.  $P = A - N = E - T = D - L = C - M = B$ 
scores M1A1 (change status stated)
- $P - A = N - E = T - D = L - C = M - B$   
 c.s.  $P = A - N = E - T = D - L = C - M = B$ 
scores M1A1 (change status stated and shown)
- $P - A = N - E = T - D = L - C = M - B$   
 $P = A, N = E, T = D, \dots$ 
scores M1A0 (no change status stated or shown)

b2A1: CAO – must follow from the correct stated path. Accept either stated **or** on a **clear** diagram (with five arcs **only**)

Question Number	Scheme	Marks
2.		M1 (7 activities, 1 start and 2 dummies) A1 (ABCDEF) A1 (GH + first two dummies) A1 (IJK) A1 CSO <b>5 marks</b>

### Notes for Question 2

Condone lack of, or incorrect, numbered events throughout and arcs which cross one another. ‘Dealt with correctly’ means that the activity starts from the correct event but need not necessarily finish at the correct event, e.g. ‘J dealt with correctly’ requires the correct precedences for this activity, i.e. D and G labelled correctly and leading into the same node and J starting from that node but not necessarily J leading into the end node. **Activity on node is M0**

#### Ignore incorrect or lack of arrows on the activities for the first four marks only

1M1: 7 activities (labelled on arc), one start and two dummies placed

1A1: Activities A, B, C, D, E and F dealt with correctly

2A1: Activities G, H and the first two dummies (including arrows on these two dummies) dealt with correctly. By ‘first two dummies’ these are the ones leading into the event at the end of E

3A1: Activities I, J and K dealt with correctly

4A1: CSO (all four previous marks must have been awarded) – final dummy correctly placed, **all** arrows present and correctly placed with one finish and no additional dummies. **Please check all arcs carefully for arrows**

**Note that there are a number of additional valid solutions in which the candidate may finish their network diagram which are different (but are equivalent) to the example given above:**

e.g.

- the arrow on the final dummy between J and K reversed so that activity H will now end at the finish node
- Activities J and K interchanged
- A combination of both points above (i.e. J and K interchanged and the arrow on the dummy reversed)
- Activity H leading directly into the finish node

Therefore it is vital that the diagram is checked carefully for these other equally acceptable/valid solutions

Question Number	Scheme	Marks
3. (a)	<p>e.g. using middle right</p> <p>59 45 18 55 47 <span style="border: 1px solid black; padding: 2px;">11</span> 63 17 15 42      pivot 11</p> <p>59 45 18 55 <span style="border: 1px solid black; padding: 2px;">47</span> 63 17 15 42 <span style="border: 1px solid black; padding: 2px;">11</span>      pivot 47</p> <p>59 <span style="border: 1px solid black; padding: 2px;">55</span> 63 <span style="border: 1px solid black; padding: 2px;">47</span> 45 18 <span style="border: 1px solid black; padding: 2px;">17</span> 15 42 <span style="border: 1px solid black; padding: 2px;">11</span>      pivot 55 17</p> <p>59 <span style="border: 1px solid black; padding: 2px;">63</span> <span style="border: 1px solid black; padding: 2px;">55</span> <span style="border: 1px solid black; padding: 2px;">47</span> 45 <span style="border: 1px solid black; padding: 2px;">18</span> 42 <span style="border: 1px solid black; padding: 2px;">17</span> 15 <span style="border: 1px solid black; padding: 2px;">11</span>      pivot 63 18 (15)</p> <p><span style="border: 1px solid black; padding: 2px;">63</span> 59 <span style="border: 1px solid black; padding: 2px;">55</span> <span style="border: 1px solid black; padding: 2px;">47</span> 45 <span style="border: 1px solid black; padding: 2px;">42</span> <span style="border: 1px solid black; padding: 2px;">18</span> <span style="border: 1px solid black; padding: 2px;">17</span> 15 <span style="border: 1px solid black; padding: 2px;">11</span>      pivot (59) 42</p> <p><span style="border: 1px solid black; padding: 2px;">63</span> 59 <span style="border: 1px solid black; padding: 2px;">55</span> <span style="border: 1px solid black; padding: 2px;">47</span> 45 <span style="border: 1px solid black; padding: 2px;">42</span> <span style="border: 1px solid black; padding: 2px;">18</span> <span style="border: 1px solid black; padding: 2px;">17</span> 15 <span style="border: 1px solid black; padding: 2px;">11</span>      (sort complete)</p>	<p>M1 (quick)</p> <p>A1 (2 passes + choice of pivot for the 3<sup>rd</sup>)</p> <p>A1ft (3<sup>rd</sup> and 4<sup>th</sup> passes correct)</p> <p>A1 (CSO)</p> <p><b>(4)</b></p>
(b)	<p>Bin 1: <u>63</u> <u>18</u> <u>17</u></p> <p>Bin 2: <u>59</u> 15 11</p> <p>Bin 3: <u>55</u> <u>45</u></p> <p>Bin 4: <u>47</u> <u>42</u></p>	<p>M1 <span style="border: 1px solid black; padding: 2px;">A1</span> A1</p> <p><b>(3)</b></p>
(c)	<p><math>\frac{372}{100} = 3.72</math> so yes the solution in (b) is optimal</p>	<p>M1 A1</p> <p><b>(2)</b></p>

### Notes for Question 3

a1M1: Quick sort, pivot, p, chosen (must be choosing middle left or right – choosing first/last item as pivot is M0). After the first pass the list must read (values greater than the pivot), pivot, (values less than the pivot). **If only choosing one pivot per iteration then M1 only** – Bubble sort is not a MR and scores M1 only for 59 45 55 47 18 63 17 15 42 11 (for left to right) or 63 59 45 18 55 47 11 42 17 15 (for right to left)

a1A1: First two passes correct **and** next pivots chosen correctly for third pass (but third pass does not need to be correct) – so they must be choosing (if middle right) pivot values of 55 and 17 for the third pass **or** (if middle left) pivot values of 59 and 17

a2A1ft: Third and fourth passes correct (follow through from their second pass and choice of pivots). They do not need to be choosing a pivot for the fifth pass for this mark

a3A1: CSO (correct solution only – all previous marks in this part **must** have been awarded) including a fifth pass in which the 42 (if middle right) or 45 (if middle left) is used as a pivot (not just stated as a pivot)

b1M1: **Must be using ‘sorted’ list** in descending order. First five items placed correctly and at least eight values placed in bins – condone cumulative totals for M1 only (the underlined values)

b1A1: First eight items placed correctly (the underlined **and** boxed values)

b2A1: CSO

**SC for part (b)** – if ‘sorted’ list is incorrect from part (a) and M0 would be awarded in (b) then award M1 only in (b) for **their** first eight items correctly placed – by ‘incorrect’ they can have only **one** error, e.g. one missing number, one extra number, or one number incorrectly placed

c1M1: Attempt to find lower bound  $(372 \pm 63) / 100$  (a value of 3.72 seen with no working can imply this mark) **or** any argument based on the four largest values

c1A1: CSO – correct calculation seen **or** 3.72 **and** a conclusion – accept ‘yes’ as a minimum conclusion – however, ‘4 is the optimal number of bins’ (or equivalent) with no reference to the solution in (b) is A0. For those using the four largest values argument they must clearly explain why two of these values cannot be placed in a bin e.g. the sum of any two of 63, 59, 55, 47 is greater than 100 so no two can be placed in a bin



Question Number	Scheme	Marks
-----------------	--------	-------

For part (a) using **middle left as pivot**

59	45	18	55	47	11	63	17	15	42	pivot	47
59	55	63	47	45	18	11	17	15	42	pivot	55 11
59	63	55	47	45	18	17	15	42	11	pivot	59 17
63	59	55	47	45	18	42	17	15	11	pivot	(63) 18 (15)
63	59	55	47	45	42	18	17	15	11	pivot	45
63	59	55	47	45	42	18	17	15	11		(sort complete)

### Misreads

- If the candidate has misread a number at the start of (a), so genuinely miscopy a number then mark the whole question as a misread – removing the last two A marks earned. This gives a maximum of total of 7 marks
- If the candidate starts the sort with the correct numbers in (a) but they misread their own numbers (so they have a copying error) during the sort then count this as an error in (a) but mark (b) and (c) as a misread. If they restart in (b) and (c) with the correct list of numbers then this is fine for full marks

### Sorting list into ascending order in (a)

- If the candidate sorts the list into ascending order and reverses the list in this part then this can score full marks in (a)
- If the list is not reversed in (a) then mark as a misread (so remove the last two A marks earned in (a)). If the list is reversed at the start of (b) but not in (a) then still treat this as a misread. If the list is in ascending order in (b) award no marks for first-fit increasing. If the candidate says that the list needs reversing in (a) but does not actually show the reversed list in (a) then remove the final A mark

### Ascending (middle right)

59	45	18	55	47	11	63	17	15	42	(11)	M1
11	59	45	18	55	47	63	17	15	42	(47)	
11	45	18	17	15	42	47	59	55	63	(17, 55)	A1
11	15	17	45	18	42	47	55	59	63	((15), 18, 63)	
11	15	17	18	45	42	47	55	59	63	(42, (59))	A1ft
11	15	17	18	42	45	47	55	59	63		A1 CSO + 'sort complete' statement

### Ascending (middle left)

59	45	18	55	47	11	63	17	15	42	(47)	M1
45	18	11	17	15	42	47	59	55	63	(11, 55)	
11	45	18	17	15	42	47	55	59	63	(17, 59)	A1
11	15	17	45	18	42	47	55	59	63	((15), 18, (63))	
11	15	17	18	45	42	47	55	59	63	(45)	A1ft
11	15	17	18	42	45	47	55	59	63		A1 CSO + 'sort complete' statement

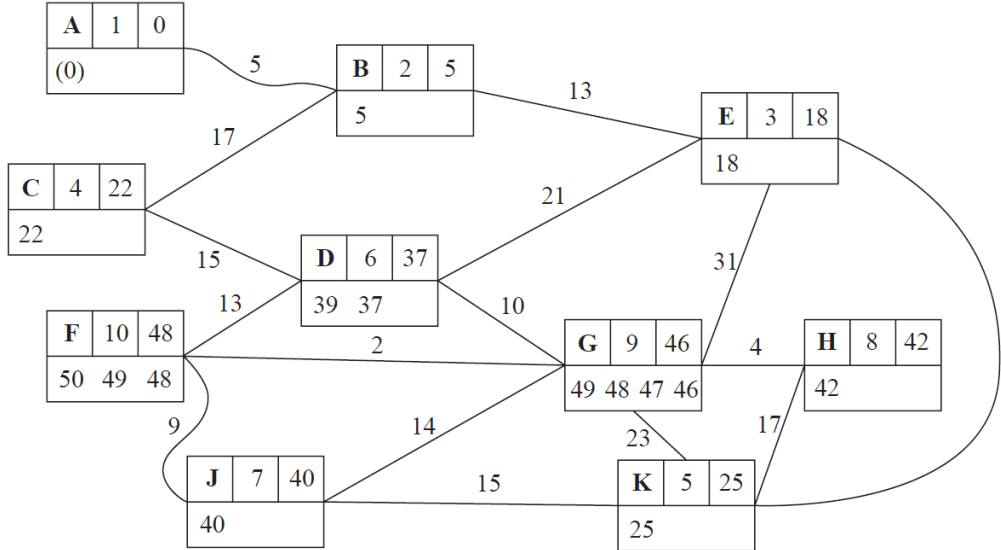
Question Number	Scheme	Marks
4. (a)	 <p>Shortest path: A – B – E – K – H – G – F Length of shortest path: 48 (miles)</p>	M1 A1 (ABECK) A1 (DJH) A1ft (GF)  A1 A1ft (6)
(b)	Shortest path via J: A – B – E – K – J – F Length of shortest path via J: 49 (miles)	B1 B1 (2)
(c)	Prim starting at G: GF, GH, FJ, DG, JK, EK, BE, AB, CD or GF, GH, FJ, DG, CD, JK, EK, BE, AB	M1 A1 A1 (3)
(d)	80 (miles)	B1 (1) <b>12 marks</b>

**Notes for Question 4**

**In (a) it is important that all values at each node are checked very carefully – the order of the working values must be correct for the corresponding A mark to be awarded e.g. at F the working values must be 50 49 48 in that order (50 48 49 is incorrect)**

**It is also important that the order of labelling is checked carefully – some candidates start with a label of 0 at A (rather than 1) – which is fine. Also the order of labelling must be a strictly increasing sequence – so 1, 2, 3, 3, 4, ... will be penalised once (see notes below) but 1, 2, 3, 5, 6, ... is fine. Errors in the final values and working values are penalised before errors in the order of labelling**

a1M1: A larger value replaced by smaller value at least once in the working values at either D or F or G

a1A1: All values at A, B, E, C and K correct. Condone lack of 0 in A's working value – please check carefully for a 5 in the working values at B

a2A1: All values at D, J and H correct and the working values in the correct order. Penalise order of labelling only once per question (D, J and H must be labelled in that order and D must be labelled after A, B, E, C and K)

Question Number	Scheme	Marks
	<p>a3A1ft: All values in G and F correct on the follow through and the working values in the correct order. Penalise order of labelling only once per question (G and F must be labelled in that order and G labelled after all other nodes (excluding F)). <b>Note that an additional working value of 54 at G inbetween the 47 and 46 is not an error (it is the working value from J into G) so 49 48 47 54 46 is fine, however, any other number or the 54 not in this position is incorrect and scores A0 in this part</b></p> <p>To follow through G check that all the working values at G follow from the candidate's final values from nodes E, K, D, J and H (in the order that the candidate has labelled these five nodes) and that the final value, and order of labelling, follows through correctly. Repeat this process for F (which will have working values from D, J and G)</p> <p>a4A1: CAO for the path (from either A to F or F to A)</p> <p>a5A1ft: If their answer is not 48 follow through their final value at F (condone lack of units)</p> <p>b1B1: CAO (shortest path via J)</p> <p>b2B1: CAO (length of shortest path)</p> <p>c1M1: First four arcs correctly chosen in order (GF, GH, FJ, DG) or first five nodes correctly chosen in order (G, F, H, J, D). <b>If any explicit rejections seen at any point then M1 (max) only.</b> Do not accept only a list of weights for this mark. Candidates may apply Prim in matrix form so the order of the nodes may be seen at the top of a matrix – accept {-, -, -, 5, -, 2, 1, 3, 4, -} for the M mark</p> <p>c1A1: First seven arcs correctly chosen in order (GF, GH, FJ, DG, JK, EK, BE or GF, GH, FJ, DG, CD, JK, EK) or all ten nodes correctly chosen in order (G, F, H, J, D, K, E, B, A, C or G, F, H, J, D, C, K, E, B, A) Candidates may apply Prim in matrix form so the order of the nodes may be seen at the top of a matrix – accept {9, 8, 10, 5, 7, 2, 1, 3, 4, 6} or {10, 9, 6, 5, 8, 2, 1, 3, 4, 7} – do not condone any missing numbers e.g. the number 10 must be above either the C or the A</p> <p>c2A1: CSO – all <b>arcs</b> correctly <b>stated</b> and chosen in the correct order. Candidates must be considering arcs for this final mark (do not accept a list of nodes or numbers across the top of the matrix unless the correct list of arcs (in the correct order) is also seen)</p> <p><b>Misread:</b> Starting at a node other than G scores <b>M1 only</b> in (c) – <b>must</b> have the first four arcs (or five nodes) correct (and in the correct order). The most common misread is those that start at A so for M1 only – accept AB, BE, EK, JK or A, B, E, K, J</p> <p>d1B1: CAO (condone lack of units)</p>	

Question Number	Scheme						Marks
5. (a)	$x$	$y$	$t$	Is $x$ odd?	Is $x = 0$ ?		M1 (3 rows + 1 <sup>st</sup> correct)
	27	5	0	Yes			A1 (2 <sup>nd</sup> and 3 <sup>rd</sup> rows correct)
	26	(5)	5		No	Row 1	
	13	10	(5)	Yes		Row 2	
	12	(10)	15		No	Row 3	A1 (4 <sup>th</sup> , 5 <sup>th</sup> and 6 <sup>th</sup> rows correct)
	6	20	(15)	No	No	Row 4	
	3	40	(15)	Yes		Row 5	
	2	(40)	55		No	Row 6	
	1	80	(55)	Yes			
	0	(80)	135		Yes		
		(135)					
	Output = 135						A1 (CSO) (4)
(b)(i)	$x$ must be a (positive) integer and therefore $x = 122$						B1 DB1
(ii)	61						B1 (3) 7 marks

#### Notes for Question 5

**Candidates may write each changed value/statement in a new row which is fine. Assume that each row begins and ends when a value in  $x$  is changed. For example, the values in row 1 in the table above consists of the  $x$  values going from the 26 to the 13**

a1M1: At least three rows of cells in columns  $x$ ,  $y$  and  $t$  completed with a correct first row (so 26 for  $x$  and 5 for  $t$ )

a1A1: CAO – second and third rows correct (for just the columns in  $x$ ,  $y$  and  $t$ )

a2A1: CAO – fourth, fifth and sixth rows correct (for just the columns in  $x$ ,  $y$  and  $t$ )

a3A1: CSO – including the output of 135 **either** on the given line in the answer book **or clearly** stated in the table but it **must** be absolutely clear that the output is the final  $t$  value (no bod). Furthermore, all ‘yes’ and ‘no’ comments must be present in the 4<sup>th</sup> and 5<sup>th</sup> columns with no additional/incorrect ‘yes’ or ‘no’

bi1B1:  $x$  must be 122 and **any** attempt at a reason

bi2DB1: Dependent on previous B mark (so B0B1 is not possible) – 122 and a correct valid reason – e.g.  $x$  must be an integer/whole number **or**  $\frac{1}{2}$  is not odd or even **or** if you input  $\frac{1}{2}$  then you can never get to  $x = 0$  when halving, etc. Just saying that the algorithm ‘won’t work’ or that the algorithm ‘will get stuck in a loop’ or ‘not terminate’ is not sufficient for this second mark neither is the argument of subtracting 1 from a  $\frac{1}{2}$ . It must be clear **why** the algorithm won’t output a value for  $t$  with  $x = \frac{1}{2}$  - so essentially there needs to be some indication of why  $x$  will never become 0. Furthermore, just saying that  $x$  will never reach 0 is insufficient – we need an indication of **why**  $x = 0$  is not possible with a starting value of  $x = \frac{1}{2}$

bii3B1: CAO

Question Number	Scheme	Marks
6. (a)	$B(AD)E + F(J)H = 45 + 30 = 75^*$ $B(CK)F + E(DG)H = 50 + 35 = 85$ $B(CKJ)H + E(DGHJ)F = 60 + 65 = 125$ Arcs BA, AD, DE, FJ and JH will be traversed twice Route length = $384 + 75 = 459$ (metres)	M1 A1 (2 correct) A1 (3 correct) A1 A1ft (5)
(b)	e.g. if we start at an odd vertex we will finish at another odd vertex. This removes the need to repeat the route between them. So we just have to consider one repeated route rather than two	B2, 1, 0 (2)
(c)	We only have to repeat one pair of odd vertices which does not include F (BE = 45, EH = 35, BH = 60)  EH is the smallest of the repeat so repeat EH (ED, DG, GH) and therefore the guard should finish at B	M1  A1 (2)
(d)	Route e.g. FJKFCKLJHGHEDGDECBDAB  The length of the route is 419 (metres)	B1  B1ft (2) <b>11 marks</b>

#### Notes for Question 6

a1M1: Three distinct pairings of the **correct** four odd nodes  
a1A1: **Any** two rows correct including pairings **and** totals  
a2A1: **All** three rows correct including pairings **and** totals  
a3A1: CAO correct **arcs** clearly (not just in their working) stated: BA, AD, DE, FJ, JH. Accept BADE, FJH **or** BE via A and D, FH via J. Do not accept BE, FH  
a4A1ft: Correct answer of 459, or  $384 +$  their smallest repeat out of a choice of at least **two** totals seen

b1B1: One of (i) **finishing** at an odd vertex (ii) only having to **repeat one route/pairing/pair/path** (but not 'repeat only one arc') rather than two **or** having **one less route/pairing/pair/path to repeat** (but not an argument based only on arcs e.g. 'one less arc to repeat' or 'it reduces the number of arcs')  
b2B1: Correct complete argument – including both (i) and (ii) from b1B1 (so B0B1 is not possible in (b))

c1M1: Identifies the need to repeat one route of BE(45), EH(35), BH(60), which does not include F (maybe implicit) or a general comment to repeat one route that does not include F  
c1A1: Identifies EH (but not just 35) as the least of those paths not including F, **and** B as the position of the finishing vertex. Note that they must either explicitly state that EH is **the least not including F** (just stating that EH is the least is A0) **or** they list the three pairings (BE, EH, BH) **and** only these three pairings in this part and state that EH is the least

d1B1: Any correct route – checks: start at F and finishes at B, 21 vertices (repeats ED, DG, GH, and node A appears 1, B(2), C(2), D(3), E(2), F(2), G(2), H(2), J(2), K(2), L(1))

d2B1ft: Correct answer of 419 or  $384 +$  their EH (i.e. the least route that does not include F – so their smallest of BE, EH, BH – must be their smallest value (usually from (a)) not what they state/think is their smallest value). **This mark is dependent on the M mark in (a)**

Question Number	Scheme	Marks
<b>7. (a)</b>	$w = 11, x = 21, y = 17, z = 4$	B3, 2, 1, 0 <b>(3)</b>
<b>(b)</b>	<p>Timeline: 0 1 2 3 4 5 6 7 8 9 10 11 12 13 14 15 16 17 18 19 20 21 22 23 24 25 26 27 28 29 30 31 32</p> <p>Activities and their durations:</p> <ul style="list-style-type: none"> <li>A: 0 to 4</li> <li>B: 0 to 8</li> <li>C: 0 to 2</li> <li>D: 5 to 17</li> <li>E: 4 to 8</li> <li>F: 3 to 8</li> <li>G: 8 to 17</li> <li>H: 8 to 21</li> <li>I: 12 to 22</li> <li>J: 10 to 25</li> <li>K: 21 to 31</li> <li>L: 22 to 28</li> <li>M: 25 to 31</li> <li>N: 28 to 32</li> </ul>	<p>M1 A1 M1 A1 <b>(4)</b></p>
<b>(c)</b>	At time 12.5, activities H, D, G, I and J must all be happening so 5 workers	M1 A1 <b>(2)</b>
<b>(d)</b>	<p>e.g.</p> <p>Timeline: 0 1 2 3 4 5 6 7 8 9 10 11 12 13 14 15 16 17 18 19 20 21 22 23 24 25 26 27 28 29 30 31 32 33 34 35 36 37 38</p> <p>Activities and their durations:</p> <ul style="list-style-type: none"> <li>A: 0 to 4</li> <li>B: 0 to 8</li> <li>C: 0 to 2</li> <li>D: 5 to 17</li> <li>E: 4 to 8</li> <li>F: 3 to 8</li> <li>G: 8 to 17</li> <li>H: 8 to 21</li> <li>I: 12 to 22</li> <li>J: 10 to 25</li> <li>K: 21 to 31</li> <li>L: 28 to 32</li> <li>M: 25 to 31</li> <li>N: 28 to 32</li> </ul>	<p>M1 A1 A1 <b>(3)</b> <b>12 marks</b></p>

Question Number	Scheme	Marks
-----------------	--------	-------

**Notes for Question 7**

a1B1: Any two values correct (it must be clear which value corresponds to which letter)

a2B1: Any three values correct

a3B1: All four values correct

b1M1: At least 10 activities including 6 floats. A scheduling diagram scores M0

b1A1: Critical activities dealt with correctly and five other non-critical activities dealt with correctly

b2M1: Exactly 14 activities (just once) including all 10 floats (on the correct non-critical activities) – this mark is not dependent on the previous A mark

b2A1: CAO

c1M1: A statement with the correct number of workers (5) and the correct activities (H, D, G, I and J) with **any** mention of time (need not be correct)

c1A1: A correct, complete statement with details of both time ( $12 < \text{time} < 13$ ) and activities. Allow ‘on day 13’ or ‘during day 13’ as equivalent to this time interval but not ‘at day 13’ – note strict inequality for the time, for example, at time 12 is A0. Accept the time interval ‘ $12 < \text{time} < 13$ ’ for this mark or a time that implies a time strictly between  $t = 12$  and  $t = 13$

d1M1: Not a cascade chart. At most 4 workers used and at least 12 activities placed. The completion time must be no greater than 36

d1A1: 3 workers. All 14 activities present (just once). Condone two errors either precedence or activity duration. The completion time must be no greater than 36 – see table below for IPA and duration for each activity. One activity can give rise to at most two errors; one on duration and one on IPA

d2A1: 3 workers. All 14 activities present (just once). No errors. The completion time must be 36

Activity	Duration	IPA
A	5	-
B	7	-
C	3	-
D	11	A
E	4	A
F	5	C
G	7	B, E, F
H	8	B, E, F
I	12	B, E, F
J	10	C
K	13	D, G, H
L	5	D, G, H
M	6	H
N	8	I, J

Question Number	Scheme	Marks
-----------------	--------	-------

<b>8. (a)</b>	$20x + 65y \leq 520$ or $4x + 13y \leq 104$ (oe)	B1 (1)
---------------	--	--------

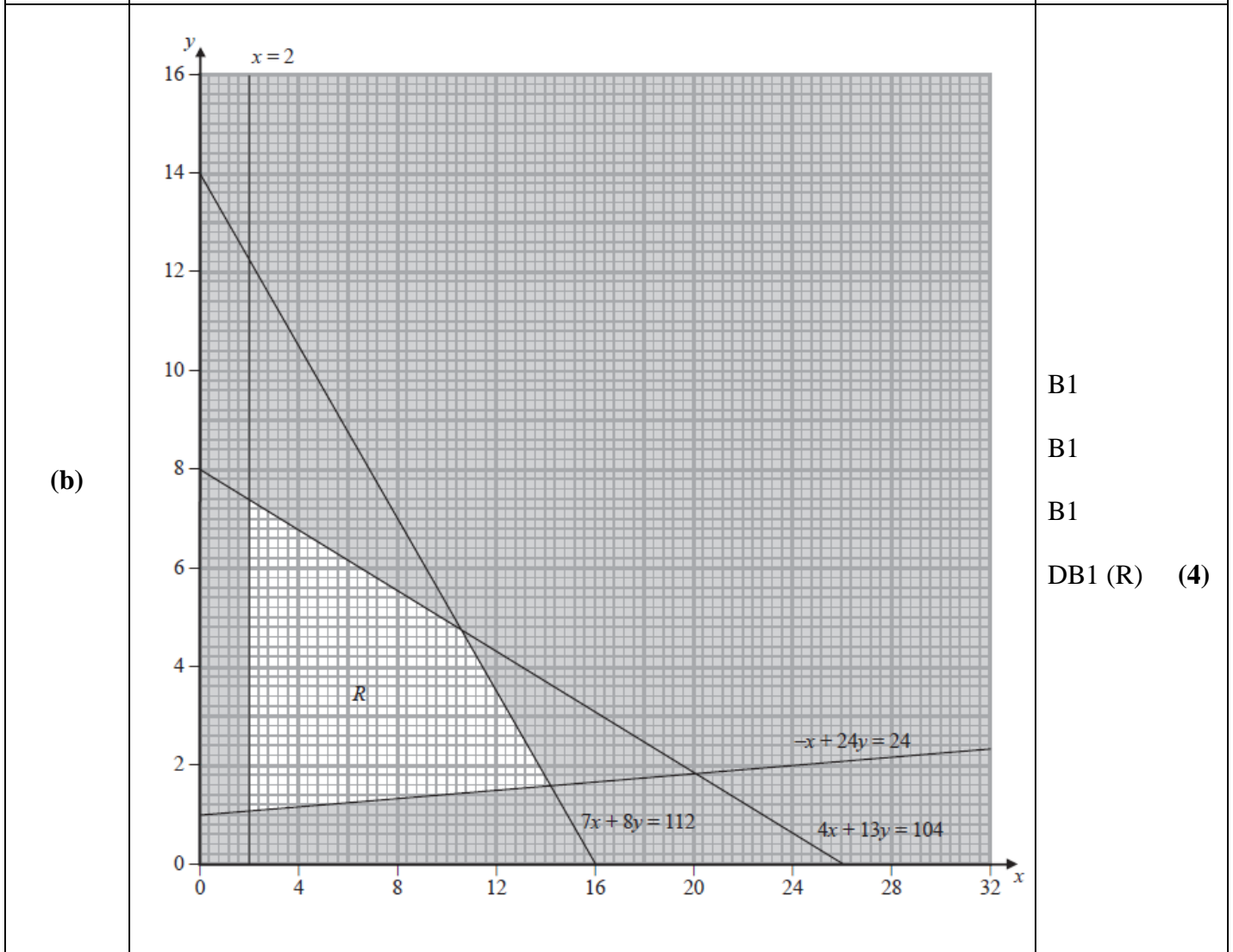

<b>(c)</b>	e.g. $(P =) 2x + 3y$	B1 (1)
------------	----------------------	--------



Question Number	Scheme	Marks
(d)	Drawing an objective line accept reciprocal gradient Correct objective line minimum length equivalent to (0, 1) to (1.5, 0) V correctly labelled	M1 A1 A1 (3)
(e)	$V\left(\frac{624}{59}, \frac{280}{59}\right)$	M1 A1 (2)
(f)	Testing integer solutions around V, $x = 11$ and $y = 4$ is optimal integer solution, so they should buy 11 standard containers and 4 deluxe containers  Cost is (£) 480	M1 A1  B1 (3) <b>14 marks</b>

### Notes for Question 8

a1B1: CAO – accept any exact equivalent inequality (isw if simplified incorrectly)

In (b):

$7x + 8y = 112$  must pass within one small square of its intersection with the axes – (0, 14) and (16, 0)

$20x + 65y = 520$  must pass within one small square of its intersection with the axes – (0, 8) and (26, 0)

$-x + 24y = 24$  must be sufficiently long to define the feasible region and pass within one small square of (0, 1) and (24, 2) if extended

$x = 2$  must pass within one small square of (2, 0) and (2, 8)

b1B1: Any two lines correctly drawn

b2B1: Any three lines correctly drawn

b3B1: All four lines correctly drawn

b4DB1: Region, R, correctly labelled – not just implied by shading – dependent on scoring the first three marks in this part

c1B1: CAO -  $k(2x + 3y)$  where  $k \in \mathbb{R}$  – condone equal to  $P$  or equal to a constant

d1M1: Drawing either the correct objective line **or** their objective line (based on their answer to (c)) **or** the reciprocal of the correct objective line **or** the reciprocal of their objective line – if their line is shorter than the length equivalent to that of the line from (0, 1) to (1.5, 0) then M0. Line must be correct to within one small square if extended from axis to axis

d1A1: Drawing the correct objective line – same condition that the line must be correct to within one small square if extended from axis to axis

d2A1: Correct V labelled clearly on their graph – **please note that this mark is dependent on scoring at least B1B1B1B0 in (b) and the two previous marks in this part** – by clearly labelled the vertex should either be labelled ‘V’ or circled or clearly distinguishable from the other three (but A0 if not clear e.g. other vertices circled too)

e1M1: Simultaneous equations being used to find V. **Must have scored at least B1B1B0B0 in (b) and candidates must have labelled one of their vertices as V (oe – see above).** Must be solving either the pair

Question Number	Scheme	Marks
	<p>of simultaneous equations <math>20x + 65y = 520</math> and <math>7x + 8y = 112</math> <b>or</b> <math>7x + 8y = 112</math> and <math>-x + 24y = 24</math>. Must be a correct method to solve simultaneous equations and must arrive at <math>x = \dots</math> and <math>y = \dots</math> but allow slips/errors. <b>This mark can also be awarded for the correct exact coordinates stated with no working provided B1B1B0B0 in (b) and a vertex labelled as V</b></p> <p>e1A1: Correct exact coordinates of the correct V derived with working (not just stated) as either <math>\left(\frac{624}{59}, \frac{280}{59}\right)</math> or <math>\left(10\frac{34}{59}, 4\frac{44}{59}\right)</math> or stated just in terms of <math>x</math> and <math>y</math>. <b>Note that this mark is dependent on B1B1B1B0 scored in (b) and all three marks in (d).</b> ISW if correct exact values seen followed by decimal approximations</p> <p>f1M1: Testing any two of (11, 4) or (9, 5) or (10, 5) or (10, 4) or (11, 5) in a correct objective function <b>or</b> the correct pair of inequalities. Note candidates may reject a point after testing in only one correct inequality which is acceptable – <b>this mark is not dependent on any previous mark</b></p> <p>f1A1: CSO (<b>all previous 12 marks must have been awarded</b>) – must have tested (11, 4) in the correct objective function <b>or</b> correct pair of inequalities – accept <math>x = 11</math> and <math>y = 4</math> or stated as a pair of coordinates</p> <p>f1B1: CAO – this mark is not dependent on any previous mark and condone lack of units</p>	

