

Paper Reference(s)

6673

Edexcel GCE

Pure Mathematics P3

Advanced/Advanced Subsidiary

Monday 10 January 2005 – Afternoon

Time: 1 hour 30 minutes

Materials required for examination

Mathematical Formulae (Lilac)

Items included with question papers

Nil

Candidates may only use one of the basic scientific calculators approved by the Qualifications and Curriculum Authority.

Instructions to Candidates

In the boxes on the answer book, write the name of the examining body (Edexcel), your centre number, candidate number, the unit title (Pure Mathematics P3), the paper reference (6673), your surname, initials and signature.

When a calculator is used, the answer should be given to an appropriate degree of accuracy.

Information for Candidates

A booklet 'Mathematical Formulae and Statistical Tables' is provided.

Full marks may be obtained for answers to ALL questions.

This paper has seven questions.

The total mark for this paper is 75.

Advice to Candidates

You must ensure that your answers to parts of questions are clearly labelled.

You must show sufficient working to make your methods clear to the Examiner. Answers without working may gain no credit.

1.
$$f(x) = 2ax^3 - ax^2 - 3x + 7,$$

where a is a constant.

Given that the remainder when $f(x)$ is divided by $(x + 2)$ is -3 ,

(a) find the value of a , (3)

(b) find the remainder when $f(x)$ is divided by $(2x - 1)$. (2)

2. (a) Use the formulae for $\sin(A \pm B)$, with $A = 3x$ and $B = x$, to show that $2 \sin x \cos 3x$ can be written as $\sin px - \sin qx$, where p and q are positive integers. (3)

(b) Hence, or otherwise, find $\int 2 \sin x \cos 3x \, dx$. (2)

(c) Hence find the exact value of $\int_{\frac{\pi}{2}}^{\frac{5\pi}{6}} 2 \sin x \cos 3x \, dx$. (2)

3. A circle C_1 has equation

$$x^2 + y^2 - 12x + 4y + 20 = 0.$$

(a) Find the coordinates of the centre of C_1 . (2)

(b) Find the radius of C_1 . (2)

The circle C_1 cuts the x -axis at the points A and B .

(c) Find an equation of the circle C_2 with diameter AB . (6)

4.
$$f(x) = \frac{1}{\sqrt{1-x}} - \sqrt{1+x}, \quad -1 < x < 1.$$

(a) Find the series expansion of $f(x)$, in ascending powers of x , up to and including the term in x^3 . (6)

(b) Hence, or otherwise, prove that the function f has a minimum at the origin. (4)

5. Relative to a fixed origin O , the point A has position vector $5\mathbf{j} + 5\mathbf{k}$ and the point B has position vector $3\mathbf{i} + 2\mathbf{j} - \mathbf{k}$.

(a) Find a vector equation of the line L which passes through A and B . (2)

The point C lies on the line L and OC is perpendicular to L .

(b) Find the position vector of C . (5)

The points O , B and A , together with the point D , lie at the vertices of parallelogram $OBAD$.

(c) Find, the position vector of D . (2)

(d) Find the area of the parallelogram $OBAD$. (4)

6.

Figure 1

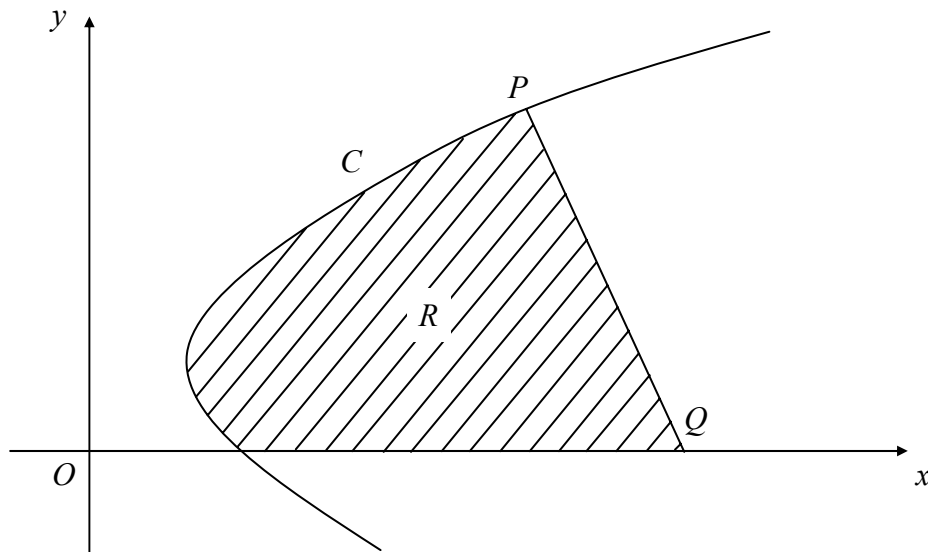

Figure 1 shows a sketch of part of the curve C with parametric equations

$$x = t^2 + 1, \quad y = 3(1 + t).$$

The normal to C at the point $P(5, 9)$ cuts the x -axis at the point Q , as shown in Figure 1.

(a) Find the x -coordinate of Q .

(6)

(b) Find the area of the finite region R bounded by C , the line PQ and the x -axis.

(9)

7. (a) Use integration by parts to show that

$$\int x \operatorname{cosec}^2\left(x + \frac{\pi}{6}\right) dx = -x \cot\left(x + \frac{\pi}{6}\right) + \ln\left[\sin\left(x + \frac{\pi}{6}\right)\right] + c, \quad -\frac{\pi}{6} < x < \frac{\pi}{3}. \quad (3)$$

- (b) Solve the differential equation

$$\sin^2\left(x + \frac{\pi}{6}\right) \frac{dy}{dx} = 2xy(y + 1)$$

to show that $\frac{1}{2} \ln\left|\frac{y}{y+1}\right| = -x \cot\left(x + \frac{\pi}{6}\right) + \ln\left[\sin\left(x + \frac{\pi}{6}\right)\right] + c.$ (6)

Given that $y = 1$ when $x = 0$,

- (c) find the exact value of y when $x = \frac{\pi}{12}.$ (6)

TOTAL FOR PAPER: 75 MARKS

END