



*Rewarding Learning*

ADVANCED SUBSIDIARY (AS)  
General Certificate of Education  
2009

---

## Mathematics

Assessment Unit C1

*assessing*

Module C1: AS Core Mathematics 1

[AMC11]



FRIDAY 5 JUNE, AFTERNOON

---

### TIME

1 hour 30 minutes.

### INSTRUCTIONS TO CANDIDATES

Write your Centre Number and Candidate Number on the Answer Booklet provided.

Answer **all eight** questions.

Show clearly the full development of your answers.

Answers should be given to three significant figures unless otherwise stated.

**You are not permitted to use any calculating aid in this paper.**

### INFORMATION FOR CANDIDATES

The total mark for this paper is 75

Figures in brackets printed down the right-hand side of pages indicate the marks awarded to each question or part question.

A copy of the **Mathematical Formulae and Tables booklet** is provided.

**Answer all eight questions.**

**Show clearly the full development of your answers.**

**Answers should be given to three significant figures unless otherwise stated.**

**You are not permitted to use any calculating aid in this paper.**

**1** Points A and B have coordinates  $(-1, 3)$  and  $(2, -3)$

**(i)** Find the equation of the line AB. [4]

The line CD has equation

$$2y - x = 3$$

**(ii)** Find the coordinates of the point of intersection of the two lines. [3]

**2** Solve the simultaneous equations

$$2x + y + 2z = 6$$

$$4x - y + 2z = 13$$

$$2x - 2y - z = 3$$

[7]

**3 (a)** Find the equation of the tangent to the curve

$$y = 2x^3 - 4x + 5$$

at the point where  $x = 1$

[6]

**(b) (i)** Find  $\frac{dy}{dx}$  where

$$y = 4x^2 + x^{-1}$$

[2]

**(ii)** Hence find the coordinates of the turning point of the curve

$$y = 4x^2 + x^{-1}$$

and determine its nature.

[6]

- 4 (i) Use the factor theorem to show that  $(x - 1)$  is a factor of

$$9x^3 - 9x^2 - x + 1 \quad [2]$$

- (ii) Hence fully factorise

$$9x^3 - 9x^2 - x + 1 \quad [3]$$

- (iii) Hence simplify fully

$$\frac{9x^3 - 9x^2 - x + 1}{3x - 1} \div \frac{x - 1}{4} \quad [4]$$

- 5 The temperature,  $C^\circ$ centigrade, of a cup of tea  $t$  minutes after it has been made is given by the formula

$$C = 80 - 10t + \frac{1}{2}t^2$$

which is valid for  $0 \leq t \leq 10$

- (i) Find the initial temperature of the cup of tea. [1]

- (ii) Find  $t$  when  $C = 50$ , leaving your answer in surd form. [4]

- (iii) Find the rate of change of  $C$  when  $t = 3$  [4]

- 6 A closed box in the shape of a cuboid has width  $x$  cm, length  $y$  cm and height 3 cm, as shown in **Fig. 1** below.

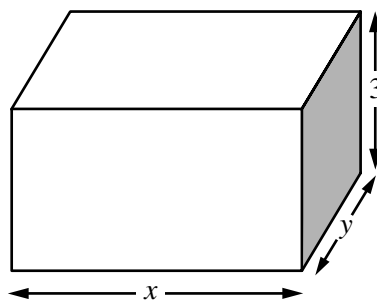

**Fig. 1**

Its volume is  $66 \text{ cm}^3$

- (i) Write down an equation for  $y$  in terms of  $x$ . [2]

The surface area of the box is  $101 \text{ cm}^2$

- (ii) Write down a second equation connecting  $x$  and  $y$ . [2]

- (iii) Hence find the dimensions of the box. [5]

7 (a) Simplify as far as possible

$$\frac{5}{\sqrt{3}+1} - \frac{1}{1-\sqrt{3}} \quad [4]$$

(b) Find  $x$  given that

$$\frac{5^x}{25^{x-1}} = \sqrt{5} \quad [6]$$

(c) **Fig. 2** below shows the graph of the function  $y = f(x)$

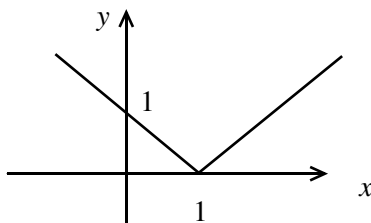

**Fig. 2**

Sketch the graph of  $y = f(2x)$  clearly identifying the points where the graph crosses or touches the axes. [2]

8 Find the range of values of  $k$  for which the equation

$$x^2 + (3 - k)x + 7 = 0$$

has no real roots. Leave your answer in surd form. [8]

---

**THIS IS THE END OF THE QUESTION PAPER**

---





Permission to reproduce all copyright material has been applied for.  
In some cases, efforts to contact copyright holders may have been unsuccessful and CCEA  
will be happy to rectify any omissions of acknowledgement in future if notified.