



ASSESSMENT and
QUALIFICATIONS
ALLIANCE

General Certificate of Education

Mathematics – Mechanics

SPECIMEN UNITS AND MARK SCHEMES

ADVANCED SUBSIDIARY MATHEMATICS (5361)
ADVANCED SUBSIDIARY PURE MATHEMATICS (5366)
ADVANCED SUBSIDIARY FURTHER MATHEMATICS (5371)

ADVANCED MATHEMATICS (6361)
ADVANCED PURE MATHEMATICS (6366)
ADVANCED FURTHER MATHEMATICS (6371)

MATHEMATICS
Unit Mechanics 1A

MM1A

In addition to this paper you will require:

- an 8-page answer book;
- a ruler;
- the AQA booklet of formulae and statistical tables.

You may use a graphics calculator.

Time allowed: 1 hour 15 minutes

Instructions

- Use blue or black ink or ball-point pen. Pencil should only be used for drawing.
- Write the information required on the front of your answer book. The *Examining Body* for this paper is AQA. The *Paper Reference* is MM1A.
- Answer **all** questions.
- Take $g = 9.8 \text{ m s}^{-2}$ unless stated otherwise.
- All necessary working should be shown; otherwise marks for method may be lost.
- The **final** answer to questions requiring the use of tables or calculators should normally be given to three significant figures.

Information

- The maximum mark for this paper is 60.
- Mark allocations are shown in brackets.

Advice

- Unless stated otherwise, formulae may be quoted, without proof, from the booklet.

Answer **all** questions.

- 1 A puck, P , of mass 3 kg is sliding across a smooth horizontal table with velocity $\begin{bmatrix} 4 \\ 3 \end{bmatrix} \text{ m s}^{-1}$ when it hits another puck, Q , of mass 5 kg sliding across the same table with velocity $\begin{bmatrix} -4 \\ -2 \end{bmatrix} \text{ m s}^{-1}$. The puck P rebounds with velocity $\begin{bmatrix} -5 \\ -3 \end{bmatrix} \text{ m s}^{-1}$. Find the velocity of Q after the collision. (4 marks)
- 2 A motorboat of mass 300 kg is travelling with constant acceleration in a horizontal straight line. The boat accelerates from a speed of 7.5 m s^{-1} to a speed of 9 m s^{-1} in 6 seconds.
- (a) Calculate the acceleration of the boat. (2 marks)
- (b) Calculate the distance that the boat travels in the 6 seconds. (3 marks)
- (c) The resistance to the motion of the boat is 325 N. Find the forward force exerted by the engine of the boat. (3 marks)
- 3 Two particles are connected by a light, inextensible string which hangs over a smooth, light pulley. The particles are of mass 2 kg and 3 kg. The system is shown in the diagram below.

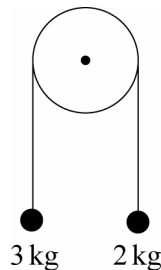

The system is released from rest, with the particles at the same height and with the string taut.

- (a) By forming an equation of motion for each particle, show that the tension in the string is 23.52 N. (6 marks)
- (b) Find the magnitude of the acceleration of the particles. (2 marks)

- 4 A sledge is modelled as a particle of mass 15 kg. The diagram shows the forces that act on the sledge as it is pulled across a rough horizontal surface. The coefficient of friction between the sledge and the ground is 0.4.

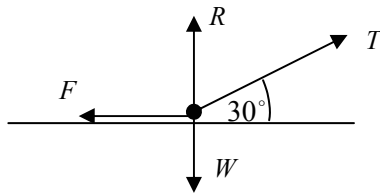

- (a) Show that the weight, W , of the sledge is 147 newtons. (1 mark)
- (b) Given that $T = 80$ newtons, show that $R = 107$ newtons. (3 marks)
- (c) Find the magnitude of the friction force acting on the sledge. (2 marks)
- (d) Find the acceleration of the sledge. (3 marks)
- (e) The sledge is initially at rest. Find the speed of the sledge after it has been moving for 3 seconds. (2 marks)
- 5 A particle is at a point O on a smooth horizontal surface. It is acted on by three horizontal forces of magnitudes 6 N, 8 N and a N. Relative to horizontal axes Ox and Oy , the directions of these three forces are shown in the diagram. The resultant, \mathbf{R} , of these forces acts along the line Oy .

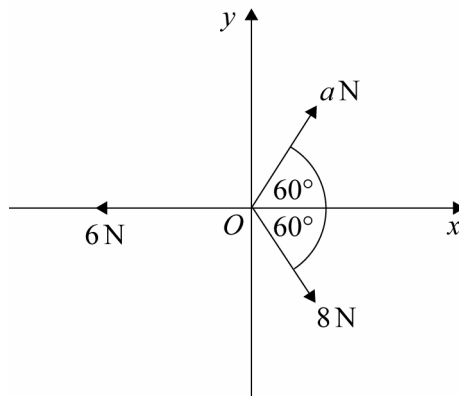

- (a) Show that $a = 4$. (4 marks)
- (b) Find the magnitude of \mathbf{R} . (3 marks)

Turn Over ►

- 6 A child throws a stone from the top of a vertical cliff and the stone subsequently lands in the sea.

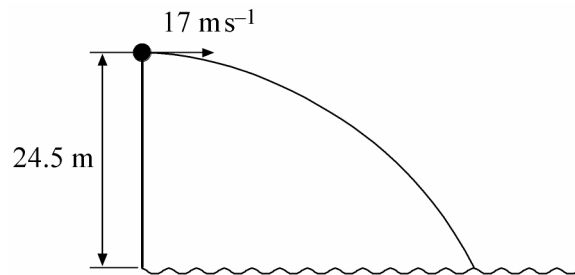

The stone is thrown from a height of 24.5 metres above the level of the sea. The initial velocity of the stone is horizontal and has magnitude 17 m s^{-1} , as shown in the diagram.

- (a) Find the time between the stone being thrown and it reaching the sea. *(3 marks)*
- (b) Find the horizontal distance between the foot of the cliff and the point where the stone reaches the sea. *(2 marks)*
- (c) Find the **speed** of the stone as it reaches the sea. *(5 marks)*
- 7 At time $t = 0$, a boat is at the origin travelling due east with speed 3 m s^{-1} . The boat experiences a constant acceleration of $(-0.2\mathbf{i} - 0.3\mathbf{j}) \text{ m s}^{-2}$. The unit vectors \mathbf{i} and \mathbf{j} are directed east and north respectively.
- (a) Write down the initial velocity of the boat. *(1 mark)*
- (b) Find an expression for the position of the boat at time t seconds. *(2 marks)*
- (c) Find the time when the boat is due south of the origin. *(3 marks)*
- (d) Find the distance of the boat from the origin when it is travelling south-east. *(6 marks)*

END OF QUESTIONS

MM1A Specimen

Question	Solution	Marks	Total	Comments
1	$3 \begin{bmatrix} 4 \\ 3 \end{bmatrix} + 5 \begin{bmatrix} -4 \\ -2 \end{bmatrix} = 3 \begin{bmatrix} -5 \\ -3 \end{bmatrix} + 5 \begin{bmatrix} x \\ y \end{bmatrix}$ $\begin{bmatrix} -8 \\ -1 \end{bmatrix} = \begin{bmatrix} -15 \\ -9 \end{bmatrix} + 5 \begin{bmatrix} x \\ y \end{bmatrix}$ $5 \begin{bmatrix} x \\ y \end{bmatrix} = \begin{bmatrix} 7 \\ 8 \end{bmatrix}$ $\text{Velocity} = \begin{bmatrix} 1.4 \\ 1.6 \end{bmatrix} \text{ (ms}^{-1}\text{)}$	<p>M1</p> <p>A1A1</p> <p>A1✓</p>	<p>4</p>	<p>Conservation of momentum</p> <p>A1 For each side of equation</p> <p>ft one slip</p>
	Total		4	
2(a)	$v = u + at$ $9 = 7.5 + a \times 6$ $a = 0.25 \text{ ms}^{-1}$	<p>M1</p> <p>A1</p>	<p>2</p>	
(b)	$s = \frac{1}{2}(7.5 + 9) \times 6$ $= 49.5\text{m}$	<p>M1A1</p> <p>A1</p>	<p>3</p>	
(c)	$P - 325 = 300 \times 0.25$ $P = 400\text{N}$	<p>M1A1</p> <p>A1</p>	<p>3</p>	
	Total		8	

MM1A (cont)

Question	Solution	Marks	Total	Comments
3(a)	$3g - T = 3a$ $T - 2g = 2a$ $6g - 2T = 3T - 6g$ $T = \frac{12g}{5} = 23.52\text{N}$	M1A1 M1A1 M1 A1	6	
(b)	$2a = 23.52 - 2 \times 9.8$ $a = \frac{3.92}{2} = 1.96\text{ms}^{-2}$	M1 A1	2	
Total			8	
4(a)	$W = 15 \times 9.8 = 147\text{N}$	B1	1	
(b)	$R + 80 \sin 30^\circ = 147$ $R = 147 - 40 = 107\text{N}$	M1A1 A1	3	
(c)	$F = 0.4 \times 107 = 42.8\text{N}$	M1A1	2	
(d)	$15a = 80 \cos 30^\circ - 42.8$ $a = \frac{80 \cos 30^\circ - 42.8}{15} = 1.77\text{ms}^{-2}$	M1A1 A1	3	
(e)	$v = 1.77 \times 3 = 5.30\text{ms}^{-1}$	M1A1	2	
Total			11	
5(a)	$6 = 8 \cos 60^\circ + a \cos 60^\circ$ $6 = 4 + \frac{1}{2}a$ $\frac{1}{2}a = 2$ $a = 4$	M1A1 M1A1	4	
(b)	$R = 4 \sin 60^\circ - 8 \sin 60^\circ$ $= -3.46$ Magnitude = 3.46N	M1A1 A1	3	
Total			7	

MM1A (cont)

Question	Solution	Marks	Total	Comments
6(a)	$24.5 = 0 + \frac{1}{2} \times 9.8 \times t^2$ $t = \sqrt{5}$ or 2.24	M1A1 A1	3	Horizontal component
(b)	$x = 17 \times \sqrt{5}$ $x = 38.0$ metres	M1 A1✓	2	
(c)	vert: velocity = $0 + 9.8 \times \sqrt{5}$ $= 21.91$	M1 A1✓		
	$v^2 = 17^2 + 21.91^2$ $v = 27.7$	B1 M1 A1✓	5	
Total			10	
7(a)	$3\mathbf{i}$	B1	1	
(b)	$\mathbf{r} = (3\mathbf{i})t + \frac{1}{2}(-0.2\mathbf{i} - 0.3\mathbf{j})t^2$ $= (3t - 0.1t^2)\mathbf{i} - 0.15t^2\mathbf{j}$	M1A1	2	
(c)	$3t - 0.1t^2 = 0$ $t(3 - 0.1t) = 0$ $t = 0$ or $t = 30$ $t = 30$ as at origin when $t = 0$	M1 M1 A1	3	
(d)	$\mathbf{v} = (3 - 0.2t)\mathbf{i} - 0.3t\mathbf{j}$ $3 - 0.2t = 0.3t$ $t = 6$ $\mathbf{r} = 14.4\mathbf{i} - 5.4\mathbf{j}$ $r = \sqrt{14.4^2 + 5.4^2} = 15.4$ m	M1 M1 A1 M1 M1A1	6	
Total			12	
TOTAL			60	

General Certificate of Education
Specimen Unit
Advanced Subsidiary Examination



MATHEMATICS
Unit Mechanics 1B

MM1B

In addition to this paper you will require:

- an 8-page answer book;
 - the AQA booklet of formulae and statistical tables.
- You may use a graphics calculator.

Time allowed: 1 hour 30 minutes

Instructions

- Use blue or black ink or ball-point pen. Pencil should only be used for drawing.
- Write the information required on the front of your answer book. The *Examining Body* for this paper is AQA. The *Paper Reference* is MM1B.
- Answer **all** questions.
- Take $g = 9.8 \text{ ms}^{-2}$ unless stated otherwise.
- All necessary working should be shown; otherwise marks for method may be lost.
- The **final** answer to questions requiring the use of tables or calculators should normally be given to three significant figures.

Information

- The maximum mark for this paper is 75.
- Mark allocations are shown in brackets.

Advice

- Unless stated otherwise, formulae may be quoted, without proof, from the booklet.

Answer **all** questions.

- 1 A puck, P , of mass 3kg is sliding across a smooth horizontal table with velocity $\begin{bmatrix} 4 \\ 3 \end{bmatrix} \text{ms}^{-1}$ when it hits another puck, Q , of mass 5kg sliding across the same table with velocity $\begin{bmatrix} -4 \\ -2 \end{bmatrix} \text{ms}^{-1}$.

The puck, P , rebounds with velocity $\begin{bmatrix} -5 \\ -3 \end{bmatrix} \text{ms}^{-1}$. Find the velocity of Q after the collision.

(4 marks)

- 2 The graph shows how the velocity, $v \text{ m s}^{-1}$ of a train varies with time t seconds as it moves on a set of straight, horizontal tracks.

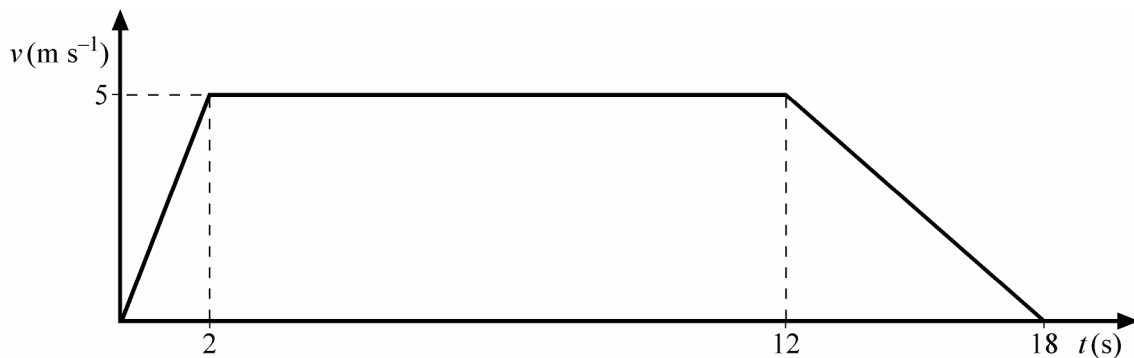

- (a) Calculate the distance of the train from its starting position when $t = 18$. (3 marks)
- (b) Calculate the acceleration of the train in the first stage of its motion. (1 mark)
- (c) State the time for which the resultant force on the train is in the direction of motion. (1 mark)
- (d) Model the train as a particle of mass 50 000kg. Assume that two horizontal forces act on the train as it moves. One has magnitude Q and acts in the direction of motion. The second is a constant resistance force of magnitude 10 000 newtons.
- (i) State the value of Q when the train is moving at a constant speed. (1 mark)
- (ii) Find the value of Q for $0 \leq t < 2$. (3 marks)

- 3 Three particles, A , B and C lie in on a straight line on a smooth horizontal surface. The masses of the particles are 2 kg , 3 kg and $m\text{ kg}$ respectively.
- (a) The particle A is set into motion, so that it moves towards B with speed 6 ms^{-1} . When it collides with B the two particles coalesce and move with speed $v\text{ ms}^{-1}$ towards C . Find v .
(3 marks)
- (b) The combined particle then hits C . After this collision, C moves with a speed of 0.7 ms^{-1} and the combined particle (A and B) travels with speed of 0.4 ms^{-1} in the opposite direction. Find m .
(4 marks)
- 4 Two particles are connected by a light, inextensible string that passes over a smooth, light pulley. The particles are of mass 2 kg and 3 kg . The system is shown in the diagram below.

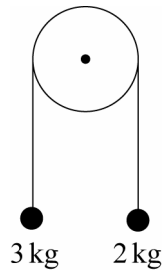

The system is released from rest, with the particles at the same height and with the string taut.

- (a) By forming an equation of motion for each particle, show that the tension in the string is 23.52 N .
(6 marks)
- (b) Find the magnitude of the acceleration of the particles.
(2 marks)
- (c) If the pulley was not smooth, how would your answer to part (b) change?
(2 marks)
- (d) If you were to take air resistance into account, how would your answer to part (b) change? Give a reason for your answer.
(2 marks)

Turn over ▶

- 5 A sledge is modelled as a particle of mass 15 kg. The diagram shows the forces that act on the sledge as it is pulled across a rough horizontal surface. The coefficient of friction between the sledge and the ground is 0.4.

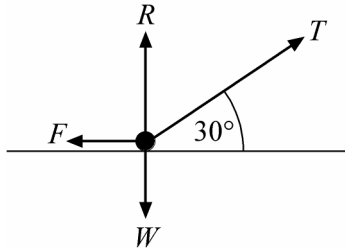

- (a) Show that the weight, W , of the sledge is 147 newtons. *(1 mark)*
- (b) Given that $T = 80$ newtons, show that $R = 107$ newtons. *(3 marks)*
- (c) Find the magnitude of the friction force acting on the sledge. *(2 marks)*
- (d) Find the acceleration of the sledge. *(3 marks)*
- (e) The sledge is initially at rest. Find the speed of the sledge after it has been moving for 3 seconds. *(2 marks)*
- 6 A sign is hung outside a shop. It has mass m kg and is held in equilibrium by two strings. The sign is modelled as a particle, P . One string is inclined at 50° to the vertical and exerts a force of 60 newtons on the particle. The other string exerts a force of magnitude T newtons at an angle of 48° to the vertical. The forces that act on the particle are shown in the diagram below.

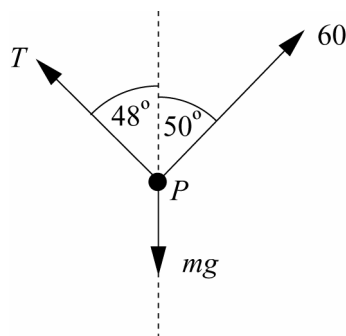

- (a) Find T . *(3 marks)*
- (b) Find m . *(3 marks)*

-
- 7 A golf ball is placed on a horizontal surface and hit. It initially moves with speed 24.5 ms^{-1} at an angle α above the horizontal. The ball hits the ground after being in the air for 2.5 seconds. Model the ball as a particle.
- (a) Show that $\alpha = 30^\circ$. *(4 marks)*
 - (b) Calculate the range of the ball. *(2 marks)*
 - (c) Find the time for which the height of the ball is greater than 3 metres. *(5 marks)*
 - (d) State one other modelling assumption that you have made. *(1 mark)*
 - (e) Describe the position of the ball when its speed is a minimum and calculate the speed of the ball in this position. *(2 marks)*
- 8 At time $t = 0$, a boat is at the origin travelling due east with speed 3 ms^{-1} . The boat experiences a constant acceleration of $(-0.2\mathbf{i} - 0.3\mathbf{j}) \text{ ms}^{-2}$. The unit vectors \mathbf{i} and \mathbf{j} are directed east and north respectively.
- (a) Write down the initial velocity of the boat. *(1 mark)*
 - (b) Find an expression for the position of the boat at time t seconds. *(2 marks)*
 - (c) Find the time when the boat is due south of the origin. *(3 marks)*
 - (d) Find the distance of the boat from the origin when it is travelling south-east. *(6 marks)*

END OF QUESTIONS

MM1B Specimen

Question	Solution	Marks	Total	Comments
1	$3 \begin{bmatrix} 4 \\ 3 \end{bmatrix} + 5 \begin{bmatrix} -4 \\ -2 \end{bmatrix} = 3 \begin{bmatrix} -5 \\ -3 \end{bmatrix} + 5 \begin{bmatrix} x \\ y \end{bmatrix}$ $\begin{bmatrix} -8 \\ -1 \end{bmatrix} = \begin{bmatrix} -15 \\ -9 \end{bmatrix} + 5 \begin{bmatrix} x \\ y \end{bmatrix}$ $5 \begin{bmatrix} x \\ y \end{bmatrix} = \begin{bmatrix} 7 \\ 8 \end{bmatrix}$ <p>Velocity = $\begin{bmatrix} 1.4 \\ 1.6 \end{bmatrix}$ (ms^{-1})</p>	M1 A1A1 A1✓	 4	Conservation of momentum for each side of equation ft one slip
Total			4	
2 (a)	$s = \frac{1}{2} \times 2 \times 5 + 5 \times 10 + \frac{1}{2} \times 5 \times 6$ $= 70 \text{ m}$	M1 A1 A1	3	
(b)	$a_1 = \frac{5}{2} = 2.5 \text{ ms}^{-2}$	B1	1	
(c)	$0 \leq t \leq 2$	B1	1	
(d) (i)	$Q = 10000 \text{ N}$	B1	1	
(ii)	$Q - 10000 = 50000 \times 2.5$ $Q = 135000 \text{ N}$	M1A1 A1	3	
Total			9	
3 (a)	$2 \times 6 = 5v$ $v = \frac{12}{5} = 2.4 \text{ ms}^{-1}$	M1 A1 A1	3	
(b)	$5 \times 2.4 = 5 \times (-0.4) + 0.7m$ $m = \frac{12 + 2}{0.7} = 20 \text{ kg}$	M1 A1 M1 A1	4	
Total			7	

MM1B (cont)

Question	Solution	Marks	Total	Comments
4(a)	$3g - T = 3a$ $T - 2g = 2a$ $6g - 2T = 3T - 6g$ $T = \frac{12g}{5} = 23.52 \text{ N}$	M1A1 M1A1 M1A1	6	
(b)	$2a = 23.52 - 2 \times 9.8$ $a = \frac{3.92}{2} = 1.96 \text{ ms}^{-2}$	M1 A1	2	
(c)	Reduces acceleration The friction would provide an additional force to oppose the motion	B1 B1	2	
(d)	Reduce As acceleration would be less due to air resistance force opposing motion.	B1 B1	2	
Total			11	
5(a)	$W = 15 \times 9.8 = 147 \text{ N}$	B1	1	
(b)	$R + 80 \sin 30^\circ = 147$ $R = 147 - 40 = 107 \text{ N}$	M1 A1 A1	3	
(c)	$F = 0.4 \times 107 = 42.8 \text{ N}$	M1 A1	2	
(d)	$15a = 80 \cos 30^\circ - 42.8$ $a = \frac{80 \cos 30^\circ - 42.8}{15} = 1.77 \text{ ms}^{-2}$	M1 A1 A1	3	
(e)	$v = 1.77 \times 3 = 5.30 \text{ ms}^{-1}$	M1A1	2	
Total			11	
6(a)	$T \sin 48^\circ = 60 \sin 50^\circ$ $T = \frac{60 \sin 50^\circ}{\sin 48^\circ} = 61.8 \text{ N}$	M1A1 A1	3	
(b)	$9.8 \text{ m} = 60 \cos 50^\circ + T \cos 48^\circ$ $m = \frac{60 \cos 50^\circ + 61.85 \cos 48^\circ}{9.8}$ $= 8.16 \text{ kg}$	M1A1 A1	3	
Total			6	

MM1B (cont)

Question	Solution	Marks	Total	Comments
7(a)	$0 = 24.5 \sin \alpha \times 2.5 - 4.9 \times 2.5^2$ $\sin \alpha = \frac{30.625}{61.25} = 0.5$ $\alpha = 30^\circ$	M1A1 M1A1	4	
(b)	$R = 24.5 \cos 30^\circ \times 2.5 = 53.0 \text{ m}$	M1A1	2	
(c)	$3 = 24.5 \sin 30^\circ t - 4.9t^2$ $4.9t^2 - 12.25t + 3 = 0$ $t = 2.225$ or $t = 0.275$ $2.225 - 0.275 = 1.95 \text{ seconds}$	M1A1 M1A1 A1	5	
(d)	No air resistance	B1	1	
(e)	At maximum height $24.5 \cos 30^\circ = 21.2 \text{ ms}^{-1}$	B1 B1	2	
	Total		14	
8(a)	$3\mathbf{i}$	B1	1	
(b)	$\mathbf{r} = (3\mathbf{i})t + \frac{1}{2}(-0.2\mathbf{i} - 0.3\mathbf{j})t^2$ $= (3t - 0.1t^2)\mathbf{i} - 0.15t^2\mathbf{j}$	M1A1	2	
(c)	$3t - 0.1t^2 = 0$ $t(3 - 0.1t) = 0$ $t = 0$ or $t = 30$ $t = 30$ as at origin when $t = 0$	M1 M1 A1	3	
(d)	$\mathbf{v} = (3 - 0.2t)\mathbf{i} - 0.3t\mathbf{j}$ $3 - 0.2t = 0.3t$ $t = 6$ $\mathbf{r} = 14.4\mathbf{i} - 5.4\mathbf{j}$ $r = \sqrt{14.4^2 + 5.4^2} = 15.4 \text{ m}$	M1 M1 A1 M1 M1 A1	6	
	Total		12	
	TOTAL		75	

General Certificate of Education
Specimen Unit
Advanced Level Examination

MATHEMATICS
Unit Mechanics 2A

MM2A

In addition to this paper you will require:

- an 8-page answer book;
- the AQA booklet of formulae and statistical tables.

You may use a graphics calculator.

Time allowed: 1 hour 15 minutes

Instructions

- Use blue or black ink or ball-point pen. Pencil should only be used for drawing.
- Write the information required on the front of your answer book. The *Examining Body* for this paper is AQA. The *Paper Reference* is MM2A.
- Answer **all** questions.
- Take $g = 9.8 \text{ ms}^{-2}$ unless stated otherwise.
- All necessary working should be shown; otherwise marks for method may be lost.
- The **final** answer to questions requiring the use of tables or calculators should normally be given to three significant figures.

Information

- The maximum mark for this paper is 60.
- Mark allocations are shown in brackets.

Advice

- Unless stated otherwise, formulae may be quoted, without proof, from the booklet.

Answer **all** questions.

- 1 A particle moves so that, at time t seconds, its position, \mathbf{r} metres, is given by

$$\mathbf{r} = (t^3 - 3t^2)\mathbf{i} + (4t + 2t^2)\mathbf{j}$$

where \mathbf{i} and \mathbf{j} are perpendicular unit vectors.

- (a) Find the velocity of the particle at time t . (2 marks)
- (b) Find the acceleration of the particle when $t = 2$. (3 marks)
- (c) The particle has mass 5 kg. Find the magnitude of the force acting on the particle when $t = 2$. (4 marks)
- 2 The diagram shows a uniform lamina, which consists of two rectangles $ABCD$ and $DPQR$.

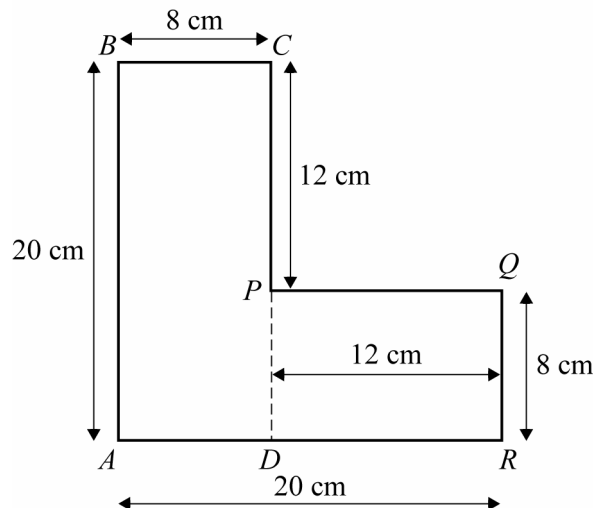

The dimensions are such that:

$$DR = PQ = CP = 12 \text{ cm};$$

$$BC = QR = 8 \text{ cm};$$

$$AB = AR = 20 \text{ cm}.$$

- (a) Explain why the centre of mass of the lamina must lie on the line AP . (1 mark)
- (b) Find the distance of the centre of mass of the lamina from AB . (4 marks)
- (c) The lamina is freely suspended from B .

Find, to the nearest degree, the angle that AB makes with the vertical through B .

(4 marks)

- 3 A car, of mass 1000 kg, has a maximum speed of 40 m s^{-1} on a straight horizontal road. When the car travels at a speed $v \text{ m s}^{-1}$, it experiences a resistance force of magnitude $35v$ newtons.

Show that the maximum power of the car is 56 000 watts. (4 marks)

- 4 The planet Jupiter has a moon, Io, whose orbit may be modelled as circular with radius 4.22×10^8 metres. The mass of Io is 8.9×10^{22} kg and the force on Io maintaining its circular path around Jupiter is 6.3×10^{22} N.

(a) Show that the speed of Io is approximately $1.73 \times 10^4 \text{ m s}^{-1}$. (4 marks)

(b) Find the time taken for Io to complete one orbit of Jupiter, giving your answer in days to two significant figures. (4 marks)

- 5 A particle of mass m is moving along a straight horizontal line. At time t the particle has speed v . Initially the particle is at the origin and has speed U . As it moves the particle is subject to a resistance force of magnitude mkv^3 .

(a) Show that $v^2 = \frac{U^2}{2kU^2t + 1}$. (6 marks)

(b) What happens to v as t increases? (1 mark)

- 6 A bungee jumper, of mass 70 kg is attached to one end of a light elastic cord of natural length 14 metres and modulus of elasticity 2744 N. The other end of the cord is attached to a bridge, approximately 40 metres above a river.

The bungee jumper steps off the bridge at the point where the cord is attached and falls vertically. The bungee jumper can be modelled as a particle throughout the motion. Hooke's law can be assumed to apply throughout the motion.

(a) Find the speed of the bungee jumper at the instant the cord first becomes taut. (2 marks)

(b) The cord extends by e metres beyond its natural length before the bungee jumper first comes momentarily to rest.

(i) Show that $e^2 - 7e - 98 = 0$. (4 marks)

(ii) Hence find the value of e . (2 marks)

(iii) Calculate the deceleration experienced by the bungee jumper at this point. (4 marks)

Turn Over ►

7 The diagram shows part of a track used by a skateboarder.

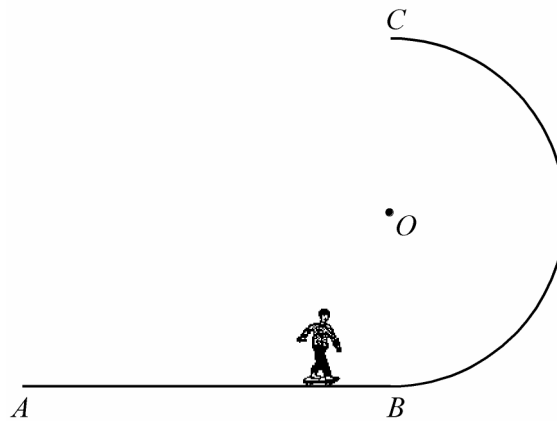

The track consists of a horizontal part AB and a curved part BC . The curved part can be modelled as a smooth semi-circular arc with centre O and radius r , with C vertically above B .

The skateboarder may be modelled as a particle moving on the track. He has a speed of $\sqrt{\frac{7gr}{2}}$ as he reaches the point B .

- (a) The point D is on the arc BC and OD makes an angle of 60° with the upward vertical. Find the speed of the skateboarder, in terms of g and r , as he reaches D . (5 marks)
- (b) Show that, at the point D , the skateboarder is about to lose contact with the track. (6 marks)

END OF QUESTIONS

MM2A Specimen

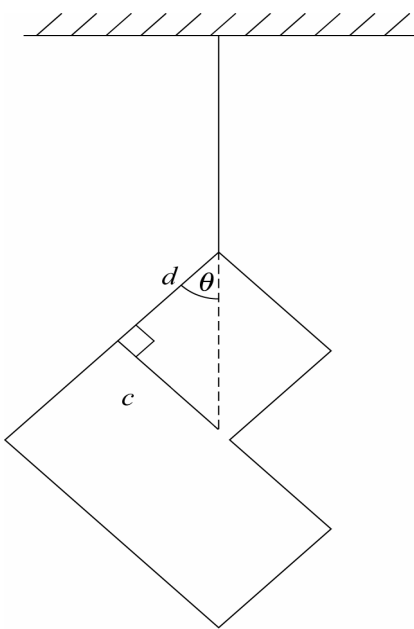
Question	Solution	Marks	Total	Comments												
1(a)	$\mathbf{v} = (3t^2 - 6t)\mathbf{i} + (4 + 4t)\mathbf{j}$	M1 A1	2													
(b)	$\mathbf{a} = (6t - 6)\mathbf{i} + 4\mathbf{j}$	M1 A1														
	$\mathbf{a}(2) = 6\mathbf{i} + 4\mathbf{j}$	A1	3													
(c)	$\mathbf{F} = 5(6\mathbf{i} + 4\mathbf{j}) = 30\mathbf{i} + 20\mathbf{j}$	M1 A1														
	$F = \sqrt{30^2 + 20^2}$	M1														
	$= 36.1 \text{ N (to 3 sf)}$	A1	4													
Total			9													
2(a)	AP is a line of symmetry	B1	1													
(b)	<table border="1" style="margin-left: auto; margin-right: auto; border-collapse: collapse;"> <thead> <tr> <th style="width: 30%;"></th> <th style="width: 20%;">Area</th> <th style="width: 50%;">Dist of C of M from CD</th> </tr> </thead> <tbody> <tr> <td style="text-align: center;"><i>ABCD</i></td> <td style="text-align: center;">160</td> <td style="text-align: center;">4</td> </tr> <tr> <td style="text-align: center;"><i>PQRD</i></td> <td style="text-align: center;">96</td> <td style="text-align: center;">14</td> </tr> <tr> <td></td> <td style="text-align: center;">256</td> <td style="text-align: center;">\bar{x}</td> </tr> </tbody> </table> <p>Using $\sum (mx) = \sum m(\bar{x})$ then $160(4) + 96(14) = 256\bar{x}$ $\bar{x} = 7.75$</p>  <p>$\tan \theta = \frac{c}{d}$ $c = 7.75$ $d = 12.25$ $\Rightarrow \theta = 32^\circ$</p>		Area	Dist of C of M from CD	<i>ABCD</i>	160	4	<i>PQRD</i>	96	14		256	\bar{x}	B1		Table values Seen or implied use
	Area	Dist of C of M from CD														
<i>ABCD</i>	160	4														
<i>PQRD</i>	96	14														
	256	\bar{x}														
		M1 A1 A1✓	4	ft slip in areas												
		M1 A1✓ A1✓		Intention to apply principle <i>c</i> correct ft part (b) ($c = \bar{x}$) <i>d</i> correct ft part (b) ($d = 20 - \bar{x}$)												
		A1	4	cao												
Total			9													

MM2A (cont)

Question	Solution	Marks	Total	Comments
3	$F = 35 \times 40 = 1400 \text{ N}$ $P = 1400 \times 40 = 56000$	M1 A1 m1 A1	4	Finding force Correct force Use of $P = Fv$ Correct final answer from correct working Negative answers do not get final A1 mark
Total			4	
4(a)	$6.3 \times 10^{22} = 8.9 \times 10^{22} \times \frac{v^2}{4.22 \times 10^8}$ $v = 1.73 \times 10^4 \text{ m s}^{-1}$	M1 M1 A1 A1	4	$F = ma$ $a = \frac{v^2}{r}$
(b)	Time = $\frac{\text{distance}}{\text{speed}}$ $= \frac{2 \times \pi \times 4.22 \times 10^8}{1.73 \times 10^4} \text{ sec}$ $= 1.8 \text{ days}$	M1 M1 A1 A1 ✓	4	
Total			8	
5(a)	$m \frac{dv}{dt} = -mkv^3$ $\int \frac{1}{v^3} dv = - \int k dt$ $-\frac{1}{2v^2} = -kt + c$ $v = U, t = 0 \Rightarrow c = -\frac{1}{2U^2}$ $\frac{1}{2v^2} = kt + \frac{1}{2U^2} = \frac{2ktU^2 + 1}{2U^2}$ $v^2 = \frac{U^2}{2ktU^2 + 1}$	M1 m1 A1 m1 A1 A1	6	Forming a differential equation Integrating to get a $\frac{1}{v^2}$ term Correct integral including c Finding c Correct c
(b)	v tends to zero	B1	1	Allow decreases
Total			7	

MM2A (cont)

Question	Solution	Marks	Total	Comments
6(a)	Rope taut (momentarily) after 14 m, so PE = KE $70g(14) = \frac{1}{2}(70)v^2$ $v^2 = 28g$ $v \approx 16.6$	M1 A1	2	For PE or KE seen
6(b)(i)	Initial PE = EPE at end $70g(14+e) = \frac{2744}{2 \times 14} e^2$ $70(14+e) = 10e^2$ $7(14+e) = e^2$ $0 = e^2 - 7e - 98$	M1 A1 B1 A1	4	Equation Fully correct For EPE (any stage) Correct quadratic
(ii)	$0 = (e - 14)(e + 7)$ $e = 14$ or -7 $\therefore e = 14\text{ m}$	M1 A1	2	
(iii)	Hooke's law, $T = \frac{\lambda}{l}e$ $\therefore T = \frac{2744}{14} \times 14 = 2744$ Newton's law, $70g - T = 70a$ $\therefore \frac{70(9.8) - 2744}{70} = a$ $a = -29.4 \text{ m s}^{-2}$	B1 M1 A1 A1	4	
Total			12	

MM2A (cont)

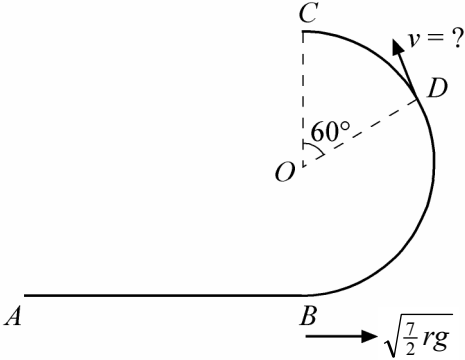
Question	Solution	Marks	Total	Comments
7(a)	 <p>Conservation of energy,</p> $\frac{1}{2} m \left[\sqrt{\frac{7}{2} rg} \right]^2 = \frac{1}{2} mv^2 + mgr(1 + \cos 60^\circ)$ $\frac{7rg}{2} = v^2 + 3gr$ $v = \sqrt{\frac{rg}{2}}$	<p>B1 M1</p> <p>A1</p> <p>A1</p> <p>A1✓</p>	<p>5</p> <p>6</p>	<p>Any one energy term correct Form equation Three non-zero terms (KE/PE) – 1EE</p> <p>Simplifying</p> <p>ft one slip</p> <p>$N + mg\cos 60^\circ$ seen or implied</p> <p>$F = ma$ radially signs consistent for A1</p> <p>Substituting and attempt to rearrange Dependent on previous M1 For $N = \dots$ Follow through one slip</p> <p>Appropriate comment relating to $N = 0$</p>
	Total		11	
	TOTAL		60	

General Certificate of Education
Specimen Unit
Advanced Level Examination



MATHEMATICS
Unit Mechanics 2B

MM2B

In addition to this paper you will require:

- an 8-page answer book;
 - the AQA booklet of formulae and statistical tables.
- You may use a graphics calculator.

Time allowed: 1 hour 30 minutes

Instructions

- Use blue or black ink or ball-point pen. Pencil should only be used for drawing.
- Write the information required on the front of your answer book. The *Examining Body* for this paper is AQA. The *Paper Reference* is MM2B.
- Answer **all** questions.
- Take $g = 9.8 \text{ ms}^{-2}$ unless stated otherwise.
- All necessary working should be shown; otherwise marks for method may be lost.
- The **final** answer to questions requiring the use of tables or calculators should normally be given to three significant figures.

Information

- The maximum mark for this paper is 75.
- Mark allocations are shown in brackets.

Advice

- Unless stated otherwise, formulae may be quoted, without proof, from the booklet.

Answer **all** questions.

- 1 A particle moves so that at time, t seconds, its position, \mathbf{r} metres, is given by,

$$\mathbf{r} = (t^3 - 3t^2)\mathbf{i} + (4t + 2t^2)\mathbf{j}, \text{ where } \mathbf{i} \text{ and } \mathbf{j} \text{ are perpendicular unit vectors.}$$

- (a) Find the velocity of the particle at time t . (2 marks)
- (b) Find the acceleration of the particle when $t = 2$. (3 marks)
- (c) The particle has mass 5 kg. Find the magnitude of the force acting on the particle when $t = 2$. (4 marks)

- 2 The diagram shows a uniform lamina, which consists of two rectangles $ABCD$ and $DPQR$.

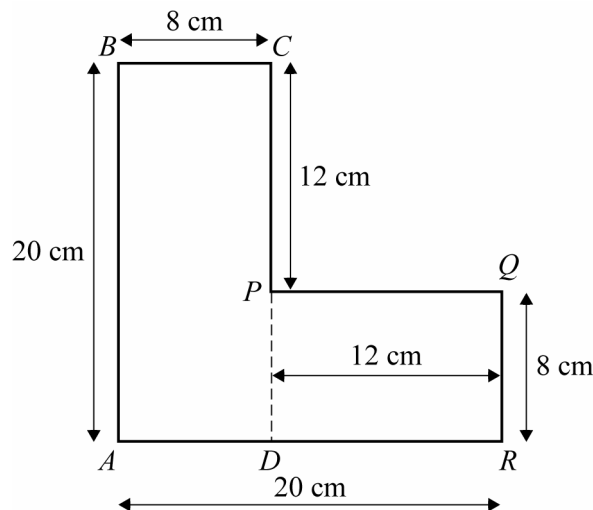

The dimensions are such that:

$$\begin{aligned} DR &= PQ = CP = 12\text{cm}; \\ BC &= QR = 8\text{cm}; \\ AB &= AR = 20\text{cm}. \end{aligned}$$

- (a) Explain why the centre of mass of the lamina must lie on the line AP . (1 mark)
- (b) Find the distance of the centre of mass of the lamina from AB . (4 marks)
- (c) The lamina is freely suspended from B .

Find to the nearest degree, the angle that AB makes with the vertical through B . (4 marks)

- 3 A car, of mass 1000kg, has a maximum speed of 40 m s^{-1} on a straight horizontal road. When the car travels at a speed $v \text{ m s}^{-1}$, it experiences a resistance force of magnitude $35v$ newtons.
- (a) Show that the maximum power of the car is 56 000 watts. *(4 marks)*
- (b) The car is travelling on a straight horizontal. Find the maximum possible acceleration of the car when its speed is 20 m s^{-1} . *(5 marks)*
- 4 The planet Jupiter has a moon, Io, whose orbit may be modelled as circular with radius 4.22×10^8 metres. The mass of Io is 8.9×10^{22} kg and the force on Io maintaining its circular path around Jupiter is 6.3×10^{22} N.
- (a) Show that the speed of Io is approximately $1.73 \times 10^4 \text{ m s}^{-1}$. *(4 marks)*
- (b) Find the time taken for Io to complete one orbit of Jupiter, giving your answer in days correct to two significant figures. *(4 marks)*
- 5 A block, of mass 2 kg, is attached to one end of a length of elastic string. The other end of the string is fixed to a wall. The block is placed on a horizontal surface as shown in the diagram below.



The elastic string has natural length 60 cm and modulus of elasticity 120 N. The block is pulled so that it is 1 metre from the wall and released from rest.

- (a) Calculate the elastic potential energy when the block is 1 metre from the wall. *(2 marks)*
- (b) If the surface is smooth, show that the speed of the block when it hits the wall is 4 m s^{-1} . *(3 marks)*
- (c) The surface is in fact rough and the coefficient of friction between the block and the surface is 0.5.
- (i) Find the speed of the block when the string becomes slack. *(4 marks)*
- (ii) Determine whether or not the block will hit the wall. *(4 marks)*

- 6 A particle of mass m is moving along a straight horizontal line. At time t the particle has speed v . Initially the particle is at the origin and has speed U . As it moves the particle is subject to a resistance force of magnitude mkv^3 .

(a) Show that $v = \frac{U^2}{2kU^{2t} + 1}$. (6 marks)

(b) What happens to v as t increases? (1 mark)

7

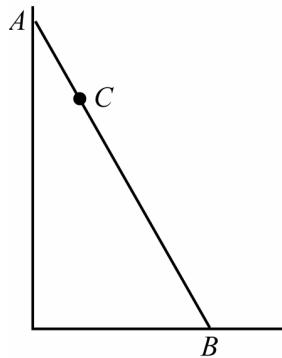

The diagram shows a uniform ladder AB of length 4 metres and mass 10kg. The ladder rests with one end A in contact with a smooth vertical wall, and the other end B in contact with a rough horizontal floor. The coefficient of friction between the ladder and the floor is 0.3. When a decorator, of mass 70 kg stands at the point C on the ladder, where $BC = 3$ metres, the ladder is on the point of slipping.

- (a) Show that the normal reaction force between the ladder and the wall at A is of magnitude 235.2N. (4 marks)
- (b) Determine the angle the ladder makes with the horizontal, giving your answer in degrees to one decimal place. (5 marks)

- 8 Maria is modelling the motion of a toy car along a “loop the loop” track.

The track, $ABCD$, can be modelled as a continuous smooth surface contained in a vertical plane. The highest point on the track is A , which is a distance h above the floor. The loop is a circle of radius r with BC as a diameter, and with C vertically above B . The track ends at the point D , as shown in the diagram.

Maria is trying to determine a connection between h and r in the case where the car stays only just in contact with the track at C .

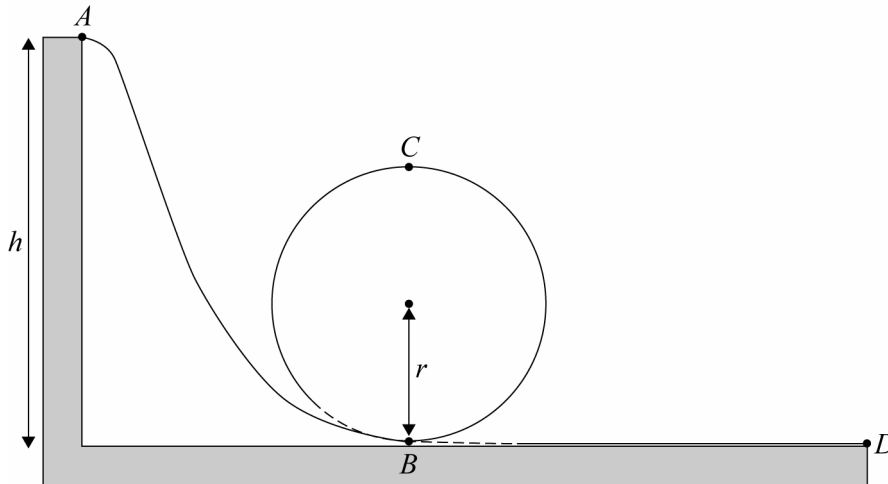

Maria models the car as a particle of mass m , which starts from rest at A . In the case where the car stays only just in contact with the track at C , it has speed u at B and speed v at C .

- By considering the forces on the car at C , show that $v^2 = rg$. (3 marks)
- Find an expression for u^2 in terms of g and r . (4 marks)
- Show that $h = kr$, where k is a constant to be determined. (3 marks)
- Suggest one improvement that could be made to the model in order to refine the solution. (1 mark)

END OF QUESTIONS

MM2B Specimen

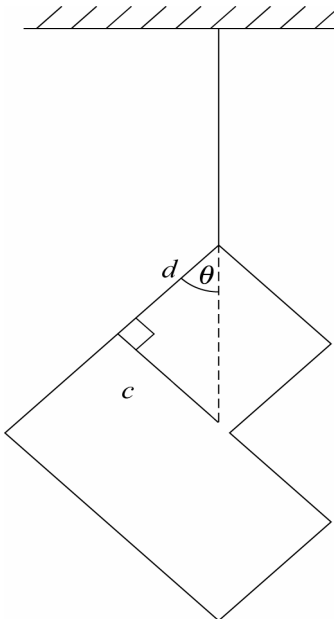
Question	Solution	Marks	Total	Comments												
1(a)	$\mathbf{v} = (3t^2 - 6t)\mathbf{i} + (4 + 4t)\mathbf{j}$	M1A1	2													
(b)	$\mathbf{a} = (6t - 6)\mathbf{i} + 4\mathbf{j}$ $\mathbf{a}(2) = 6\mathbf{i} + 4\mathbf{j}$	M1A1 A1	3													
(c)	$\mathbf{F} = 5(6\mathbf{i} + 4\mathbf{j}) = 30\mathbf{i} + 20\mathbf{j}$ $F = \sqrt{30^2 + 20^2}$ $= 36.1 \text{ N (to 3 sf)}$	M1A1 M1 A1	4													
	Total		9													
2(a)	AP is a line of symmetry	B1	1													
(b)	<table border="1" style="margin-left: auto; margin-right: auto; border-collapse: collapse;"> <thead> <tr> <th style="width: 10%;"></th> <th style="width: 20%;">Area</th> <th style="width: 20%;">Dist of C of M from CD</th> </tr> </thead> <tbody> <tr> <td><i>ABCD</i></td> <td style="text-align: center;">160</td> <td style="text-align: center;">4</td> </tr> <tr> <td><i>PQRD</i></td> <td style="text-align: center;">96</td> <td style="text-align: center;">14</td> </tr> <tr> <td></td> <td style="text-align: center;">256</td> <td style="text-align: center;">\bar{x}</td> </tr> </tbody> </table> <p>Using $\sum (mx) = \sum m(\bar{x})$ then $160(4) + 96(14) = 256\bar{x}$ $\bar{x} = 7.75$</p>  <p>$\tan \theta = \frac{c}{d}$ $c = 7.75$ $d = 12.25$ $\Rightarrow \theta = 32^\circ$</p>		Area	Dist of C of M from CD	<i>ABCD</i>	160	4	<i>PQRD</i>	96	14		256	\bar{x}	B1 B1 M1A1 A1 \checkmark	4	Table values Seen or implied use ft slip in areas
	Area	Dist of C of M from CD														
<i>ABCD</i>	160	4														
<i>PQRD</i>	96	14														
	256	\bar{x}														
		M1 A1 \checkmark A1 \checkmark A1	4	Intention to apply principle c correct ft part (b) ($c = \bar{x}$) d correct ft part (b) ($d = 20 - \bar{x}$) cao												
	Total		9													

MM2B (cont)

Question	Solution	Marks	Total	Comments
3(a)	$F = 35 \times 40 = 1400\text{N}$ $P = 1400 \times 40 = 56000$	M1 A1 dM1 A1	4	Finding force Correct force Use of $P=Fv$ Correct final answer from correct working Negative answers do not get final A1 mark
(b)	$F - 35 \times 20 = 1000a$ $F = 1000a + 700$ $56000 = 20(1000a + 700)$ $a = \frac{2800 - 700}{1000} = 2.1 \text{ m s}^{-2}$	M1 A1 dM1 dM1 A1	5	F expressed as the sum of two terms Correct F Use of $P=Fv$ Solving for a cao
Total			9	
4(a)	$6.3 \times 10^{22} = 8.9 \times 10^{22} \times \frac{v^2}{4.22 \times 10^8}$ $v = 1.73 \times 10^4 \text{ ms}^{-1}$	M1 M1 A1 A1	4	$F = ma$ $a = \frac{v^3}{7}$
(b)	Time = $\frac{\text{distance}}{\text{speed}}$ $= \frac{2 \times \pi \times 4.22 \times 10^8}{1.73 \times 10^4} \text{ sec}$ $= 1.8 \text{ days}$	M1 A1A1 A1F	4	
Total			8	
5(a)	$\text{EPE} = \frac{1}{2} \times \frac{120}{0.6} \times 0.4^2 = 16\text{J}$	M1A1	2	
(b)	$16 = \frac{1}{2} \times 2v^2$ $v^2 = 4$ $v = 2$	M1A1 A1	3	
(c)	$16 - 0.5 \times 2 \times 9.8 \times 0.4 = \frac{1}{2} \times 2v^2$ $v^2 = 12.08$ $v = 3.48 \text{ ms}^{-1}$ (to 3 sf)	M1A1 M1 A1	4	
(d)	$0.5 \times 2 \times 9.8 \times 1 = 9.8$ $9.8 < 16$ \therefore Hits the wall	M1 A1 M1 A1	4	
Total			13	

MM2B (cont)

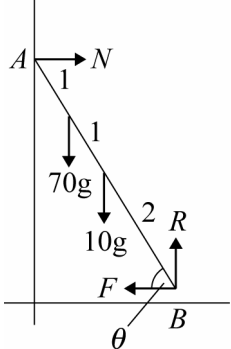
Question	Solution	Marks	Total	Comments
6(a)	$m \frac{dv}{dt} = -mkv^3$ $\int \frac{1}{v^3} dv = -\int k dt$ $-\frac{1}{2v^2} = kt + \frac{1}{2U^2} = \frac{2ktU^2 + 1}{2U^2}$ $v^2 = \frac{U^2}{2ktU^2 + 1}$	M1 dM1 A1 dM1 A1 A1	6	Forming a differential equation Integrating to get a $\frac{1}{v^2}$ term Correct integral including c Finding c Correct c Correct final answer from correct working
(b)	v tends to zero	B1	1	Allow decreases
Total			7	
7(a)	 <p> $R = 80g \quad N = F$ $F = 0.3 \times 80g$ $= 24g \quad \therefore N = 24g = 235.2N$ </p>	B1B1 M1 A1F	4	ft R
(b)	$M(B) \quad 10g \cdot 2 \cos \theta + 70g \cdot 3 \cos \theta = 24g \cdot 4 \sin \theta$ $230 \cos \theta = 96 \sin \theta$ $\tan \theta = \frac{230}{96}$ $\theta = 67.3^\circ$	M1A2 m1 A1F	5	-1 each error 5
Total			9	

MM2B (cont)

Question	Solution	Marks	Total	Comments
8(a)	At C, $N = 0$ so only force on the car will be mg Newton's law radially, $mg = \frac{mv^2}{r}$ $v^2 = gr$	B1 M1 A1	3	Stated or implied
(b)	Using conservation of energy between B and C. $\frac{1}{2}mu^2 = \frac{1}{2}mv^2 + 2mgr$ $u^2 = 5gr$	B1 M1A1 A1	4	Any KE/PE term seen Equation formed Substitute v^2 and rearrange
(c)	Using conservation of energy between A and B $mgh = \frac{1}{2}mu^2$ $\Rightarrow mgh = \frac{1}{2}m5gr$ $\Rightarrow h = 2.5r$ $\Rightarrow k = 2.5$	M1 A1 A1	3	cao
(d)	Consider resistive forces / friction – proportional to speed.	B1	1	
	Total		11	
	TOTAL		75	

MATHEMATICS
Unit Mechanics 3

MM03

In addition to this paper you will require:

- an 8-page answer book;
- the AQA booklet of formulae and statistical tables.

You may use a graphics calculator.

Time allowed: 1 hour 30 minutes

Instructions

- Use blue or black ink or ball-point pen. Pencil should only be used for drawing.
- Write the information required on the front of your answer book. The *Examining Body* for this paper is AQA. The *Paper Reference* is MM03.
- Answer **all** questions.
- Take $g = 9.8 \text{ ms}^{-2}$ unless stated otherwise.
- All necessary working should be shown; otherwise marks for method may be lost.
- The **final** answer to questions requiring the use of tables or calculators should normally be given to three significant figures.

Information

- The maximum mark for this paper is 75.
- Mark allocations are shown in brackets.

Advice

- Unless stated otherwise, formulae may be quoted, without proof, from the booklet.

Answer **all** questions.

- 1 Three smooth spheres, A , B and C are of equal size. The spheres lie at rest in a straight line on a smooth horizontal surface with B between A and C . The masses of A , B and C are m , $2m$, and $6m$, respectively, and the coefficient of restitution between any two of the spheres is e .

The sphere A is set in motion directly towards B with speed u and collides with B .

- (a) Given that A is brought to rest by the collision:

(i) find the speed of B just after the impact; *(2 marks)*

(ii) show that $e = 0.5$. *(2 marks)*

- (b) The sphere B subsequently collides with C .

Find the velocities of B and C just after this collision. *(7 marks)*

- (c) (i) Find the magnitude of the impulse on B at the collision with C . *(2 marks)*

(ii) Determine at which of the two collisions the magnitude of the impulse on B is greater. *(2 marks)*

- (d) Explain why a further collision takes place. *(1 mark)*

- 2 Sara is using the ‘vena contractor phenomenon’ to measure the rate of flow of liquid out of an inverted cone of semi-vertical angle α .

The standard formula for the rate of flow is: $R = \frac{8}{15} C_D \tan \alpha \sqrt{2gh^5}$ where C_D is the coefficient of discharge which is a dimensionless constant and h is the height of liquid in the inverted cone.

By using dimensional analysis, show that the dimension of R is a rate of flow. *(4 marks)*

- 3 Axes Ox , Oy and Oz are defined respectively in the East, North and vertically upwards directions. Unit vectors \mathbf{i} , \mathbf{j} and \mathbf{k} are defined in the x , y and z directions. The units of distance are metres and the units of velocity are metres per second.

A small plane, P , is flying between two airports, A and B , on the two islands shown. A boat, T , is travelling between two harbours C and D , on the two islands.

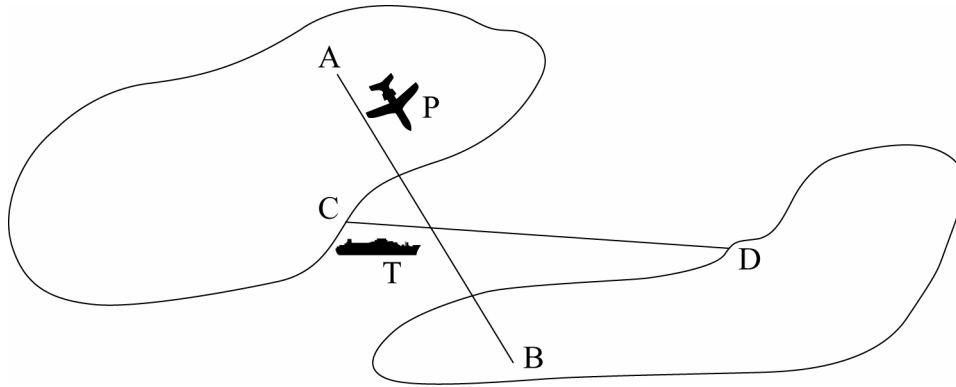

At 10 am, the plane leaves A and the boat leaves C .
 Harbour C has position vector $80\mathbf{i} - 6000\mathbf{j}$ relative to A .
 After take off, the plane travels with constant velocity $30\mathbf{i} - 25\mathbf{j} + 2.1\mathbf{k}$.
 After leaving harbour, the boat has a constant velocity $18\mathbf{i} - \mathbf{j}$.
 Time t is measured in seconds after 10am.

- (a) State the position vector of T relative to P at 10am. (1 mark)
- (b) Find the velocity of T relative to P . (2 marks)
- (c) Find an expression for the distance, S metres, between the plane and the boat at time t .
 You do **not** need to simplify your expression. (4 marks)
- (d) Find t when S^2 is a minimum.

Hence state the time at which the plane and the boat are closest. (4 marks)

Turn over ►

- 4 A shell is fired from the top of a cliff with initial velocity v and at an angle α above the horizontal. The horizontal and upward vertical distances from the point of projection are x metres and y metres respectively.

(a) Using the constant acceleration formulae, show that x and y satisfy the equation

$$y = x \tan \alpha - \frac{gx^2}{2v^2} (1 + \tan^2 \alpha)$$

(6 marks)

- (b) When $v = 70 \text{ m s}^{-1}$, the shell hits the sea at a point where $x = 400$ and $y = -50$.

Find the two possible values of $\tan \alpha$.

(6 marks)

- 5 A smooth, spherical particle, of mass $2m$, travelling with velocity $4\mathbf{i} + 5\mathbf{j}$ collides with a smooth, spherical particle of mass m which has a velocity of $-3\mathbf{i}$.

After the collision, the velocity of the particle of mass m is $3\mathbf{i} + 2\mathbf{j}$.

Find:

- (a) the velocity, after the collision, of the particle of mass $2m$; (3 marks)
- (b) the change in momentum of the particle of mass m ; (3 marks)
- (c) the direction of the line of centres of the particles, giving your answer as a vector. (2 marks)

- 6 A sphere of mass m , moving on a smooth horizontal surface, hits a smooth vertical wall. Just before it hits the wall, the sphere is moving at an angle of 60° to the wall with velocity u .

The diagram shows the view from above.

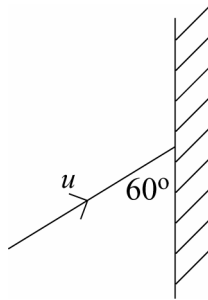

The coefficient of restitution between the wall and the sphere is $\frac{3}{4}$.

- (a) Modelling the sphere as a particle, find the angle through which the direction of motion of the sphere is changed. *(6 marks)*
- (b) The impulse exerted by the wall on the sphere acts on the sphere for 0.05 seconds. Given that $m = 0.3$ kg and $u = 5$ m s⁻¹, find the average impulsive force acting on the sphere. *(6 marks)*
- 7 A particle is projected down a plane inclined at an angle α to the horizontal. It is projected with velocity V at an angle θ to the inclined plane. The particle moves in a vertical plane containing the line of greatest slope.

- (a) Using $\cos\theta\cos\alpha + \sin\theta\sin\alpha = \cos(\theta - \alpha)$, show that the range, R , down the plane is

$$\frac{2V^2 \sin\theta \cos(\theta - \alpha)}{g \cos^2 \alpha}$$

(8 marks)

- (b) Hence, using $2 \sin A \cos B = \sin(A+B) + \sin(A-B)$, show that the maximum possible value of R is

$$\frac{V^2}{g \cos^2 \alpha} (1 + \sin \alpha)$$

(4 marks)

END OF QUESTIONS

MM03 Specimen

Question	Solution	Marks	Total	Comments
1(a)(i)	<p>Initial $\rightarrow 2u \quad \rightarrow 0$ $m \quad \quad 2m$ Final $\rightarrow 0 \quad \rightarrow V$</p> <p>Using conservation of momentum $mu = 2mV$ $V = \frac{1}{2}u$</p>	M1 A1	2	
(ii)	<p>Using restitution $(\frac{1}{2}u - 0) = e(u - 0)$ $e = \frac{1}{2}$</p>	M1 A1	2	
(b)	<p>Initial $\rightarrow \frac{1}{2}u \quad \rightarrow 0$ $2m \quad \quad 6m$ Final $\rightarrow V_1 \quad \rightarrow V_2$</p> <p>Using conservation of momentum $6mV_1 + 2mV_2 = 2m \frac{1}{2}u$</p> <p>Using restitution $V_2 - V_1 = \frac{1}{2}(\frac{1}{2}u)$</p> <p>$V_2 = \frac{3}{16}u$ $V_1 = -\frac{1}{16}u$</p>	M1 A1 M1 A1 M1 A1 A1	7	
(c)(i)	<p>Magnitude of impulse B/C is $6m \times \frac{3}{16}u = \frac{9}{8}mu$</p>	M1 A1	2	
(ii)	<p>Magnitude of impulse A/B is mu second collision causes larger magnitude of impulse.</p>	B1 B1	2	
(d)	<p>A is stationary and B is moving towards A so B will collide with A</p>	B1	1	
	Total		16	

MM03 (cont)

Question	Solution	Marks	Total	Comments
2	Dimension of h is L Dimension of g is LT^{-2} Dimension of $\frac{8}{15} C_D \tan \alpha \sqrt{2gh^5}$ is $(gh^5)^{1/2} = (LT^{-2} \cdot L^5)^{1/2}$ $= L^3 T^{-1}$ = volume/sec which is a rate of flow	B1 M1 A1 B1	4	
Total			4	
3(a)	$\mathbf{r}_{T \text{ rel } P} = \mathbf{r}_T - \mathbf{r}_P$ $= \begin{pmatrix} 80 \\ -6000 \\ 0 \end{pmatrix}$	B1	1	
(b)	$\mathbf{v}_{T \text{ rel } P} = \mathbf{v}_T - \mathbf{v}_P$ $= \begin{pmatrix} 18 \\ -1 \\ 0 \end{pmatrix} - \begin{pmatrix} 30 \\ -25 \\ 2.1 \end{pmatrix} = \begin{pmatrix} -12 \\ 24 \\ -2.1 \end{pmatrix}$	M1 A1	2	
(c)	$\mathbf{r}_{T \text{ rel } P} = \begin{pmatrix} 80 - 12t \\ -6000 + 24t \\ -2.1t \end{pmatrix}$ $D = \sqrt{\{(80 - 12t)^2 + (-6000 + 24t)^2 + (2.1t)^2\}}$	M1 A1 M1 A1	4	
(d)	$\frac{dD^2}{dt} = -24(80 - 12t) + 48(-6000 + 24t) + 8.82t$ $\frac{dD^2}{dt} = 0 \Rightarrow$ $-1920 + 288t - 288000 + 1152t + 8.82t = 0$ $t = 200.10$ time is 1003 and 20 sec	M1 M1 A1 A1	4	
Total			11	

MM03 (cont)

Question	Solution	Marks	Total	Comments
4(a)	$x = v \cos \alpha t$ $y = v \sin \alpha t - \frac{1}{2} g t^2$ $t = \frac{x}{v \cos \alpha}$ $y = v \sin \alpha \cdot \frac{x}{v \cos \alpha} - \frac{1}{2} g \left(\frac{x}{v \cos \alpha} \right)^2$ $= x \tan \alpha - \frac{g x^2}{2 v^2} \sec^2 \alpha$ $y = x \tan \alpha - \frac{g x^2}{2 v^2} (1 + \tan^2 \alpha)$	M1 M1 A1 A1 M1 A1		
(b)	when $v = 70, y = -50, x = 400$ $-50 = 400 \tan \alpha - \frac{(400)^2 g}{2 \times 4900} (1 + \tan^2 \alpha)$ $-50 = 400 \tan \alpha - 160 - 160 \tan^2 \alpha$ $16 \tan^2 \alpha - 40 \tan \alpha + 11 = 0$ $\tan \alpha = \frac{40 \pm \sqrt{896}}{32}$ or 2.185 or 0.315	M1 A1 M1 A1 A1 A1	6 6	
Total			12	
5(a)	Using C of momentum $2m \begin{pmatrix} 4 \\ 5 \end{pmatrix} + m \begin{pmatrix} -3 \\ 0 \end{pmatrix} = 2m \mathbf{v} + m \begin{pmatrix} 3 \\ 2 \end{pmatrix}$ $\begin{pmatrix} 5 \\ 10 \end{pmatrix} = 2 \mathbf{v} + m \begin{pmatrix} 3 \\ 2 \end{pmatrix}$ $\mathbf{v} = \begin{pmatrix} 1 \\ 4 \end{pmatrix}$	M1 A1 A1	3	
(b)	Change in momentum $= m \begin{pmatrix} 3 \\ 2 \end{pmatrix} - m \begin{pmatrix} -3 \\ 0 \end{pmatrix}$ $= 6m\mathbf{i} + 2m\mathbf{j}$	M1 B1 A1	3	
(c)	Direction is $3\mathbf{i} + \mathbf{j}$	B2	2	
Total			8	

MM03 (cont)

Question	Solution	Marks	Total	Comments
6(a)	Velocity parallel wall unaltered $u \cos 60 = v \cos \theta$ Velocity perpendicular to wall $e u \sin 60 = v \sin \theta$ Dividing $\tan \theta = e \tan 60$ $= \frac{3}{4} \cdot \sqrt{3}$ $\therefore \theta = 52.4^\circ$ \therefore Direction of motion is changed by 112.4°	M1 A1 M1 A1 A1 A1	6	
(b)	Impulse is change in momentum perpendicular to the wall $= m u \sin 60 + m v \sin \theta$ $= m u \sin 60 (1 + e)$ $= 0.3 \times 5 \times \frac{\sqrt{3}}{2} \times 1.75$ $= \frac{21}{16} \sqrt{3}$ Time \times impulse = change in momentum \therefore Impulse = $20 \times \frac{21}{16} \sqrt{3}$ $= 45.5$	M1 A1 A1 M1 A1 A1	6	
	Total		12	

MM03 (cont)

Question	Solution	Marks	Total	Comments
7(a)	<p>Distance perpendicular to slope:</p> $S = V \sin \theta t - \frac{1}{2} g \cos \alpha t^2$ <p>Strikes plane again when $s = 0$,</p> $t = \frac{2v \sin \theta}{g \cos \alpha}$ <p>[$t = 0$ not required]</p> <p>Distance down slope:</p> $R = V \cos \theta t + \frac{1}{2} g \sin \alpha t^2$ $= V \cos \theta \frac{2v \sin \theta}{g \cos \alpha} + \frac{1}{2} g \left\{ \frac{2v \sin \theta}{g \cos \alpha} \right\}^2$ $= \frac{2v^2 \cos \theta \sin \theta}{g \cos \alpha} + \frac{2v^2 \sin^2 \theta}{g \cos^2 \alpha}$ $= \frac{2V^2 \sin \theta [\cos \theta \cos \alpha + \sin \theta \sin \alpha]}{g \cos^2 \alpha}$ $= \frac{2V^2 \sin \theta \cos(\theta - \alpha)}{g \cos^2 \alpha}$	<p>M1</p> <p>A1</p> <p>M1A1</p> <p>M1</p> <p>M1 M1</p> <p>A1</p>	8	
(b)	<p>Range is</p> $\frac{2V^2}{g \cos^2 \alpha} \frac{1}{2} [\sin(2\theta - \alpha) + \sin \alpha]$ <p>This is a maximum when $\sin(2\theta - \alpha)$ is a maximum Which is 1 Hence maximum range is</p> $\frac{V^2}{g \cos^2 \alpha} (1 + \sin \alpha)$	<p>M1</p> <p>A1</p> <p>M1</p> <p>A1</p>	4	
	Total		12	
	TOTAL		75	

MATHEMATICS
Unit Mechanics 4

MM04

In addition to this paper you will require:

- an 8-page answer book;
 - the AQA booklet of formulae and statistical tables;
- You may use a graphics calculator

Time allowed: 1 hour 30 minutes

Instructions

- Use blue or black ink or ball-point pen. Pencil should only be used for drawing.
- Write the information required on the front of your answer book. The *Examining Body* for this paper is AQA. The *Paper Reference* is MM04.
- Answer **all** questions.
- Take $g = 9.8 \text{ m s}^{-2}$ unless stated otherwise.
- All necessary working should be shown; otherwise marks for method may be lost.
- The **final** answer to questions requiring the use of tables or calculators should normally be given to three significant figures.

Information

- The maximum mark for this paper is 75.
- Mark allocations are shown in brackets.

Advice

- Unless stated otherwise, formulae may be quoted, without proof, from the booklet.

Answer **all** questions.

- 1 Two forces, $3\mathbf{i} + 6\mathbf{j} - 2\mathbf{k}$ and $2\mathbf{i} - 2\mathbf{j} - \mathbf{k}$ act at the points whose co-ordinates are $(4, -2, 1)$ and $(5, 3, -4)$ respectively. The three unit vectors \mathbf{i} , \mathbf{j} and \mathbf{k} are mutually perpendicular. The resultant of these forces together with a force, \mathbf{F} , acting through the origin, form a couple.

Find:

- (a) (i) the force \mathbf{F} ; *(3 marks)*
- (ii) the magnitude of \mathbf{F} . *(2 marks)*
- (b) the moment of the couple. *(4 marks)*
- 2 (a) A skater rotates about a vertical axis through her centre of mass. When both her arms are fully extended horizontally, her moment of inertia about her axis of rotation is 0.6 kg m^2 , and her angular speed is 5 rad s^{-1} .
Find the angular momentum of the skater. *(2 marks)*
- (b) The skater continues to rotate but now lowers her arms until they are vertical. Her moment of inertia in this position is 0.5 kg m^2 .
Find her angular speed in this position. *(3 marks)*
- 3 A uniform solid cylinder of radius 0.4m can rotate freely about a smooth fixed horizontal axis passing along the axis through the centre of its plane faces. The moment of inertia of the cylinder about this axis is 8 kg m^2 . A light inextensible string is wound round the cylinder and is pulled off horizontally with a constant force of 200N as shown in the diagram.

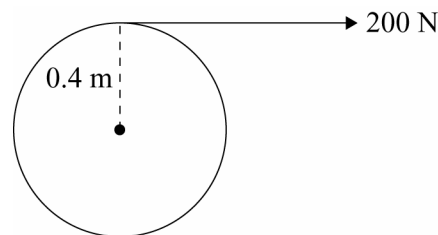

Initially the cylinder is at rest.

Find:

- (a) the angular acceleration of the cylinder. *(3 marks)*
- (b) the angular velocity of the cylinder when it has turned through two revolutions. *(5 marks)*

4 A uniform, solid hemisphere has radius a .

- (a) Show that the centre of mass of the hemisphere is at a distance $\frac{3a}{8}$ from its flat face. (5 marks)
- (b) The hemisphere is suspended from a point at the edge of its flat face. Find the angle between the flat face and the vertical when the hemisphere is in equilibrium. (2 marks)

- 5 (a) Show by integration that the moment of inertia of a uniform rod of mass m and length $6a$ about an axis through one end of the rod and perpendicular to the rod is $12ma^2$. (5 marks)

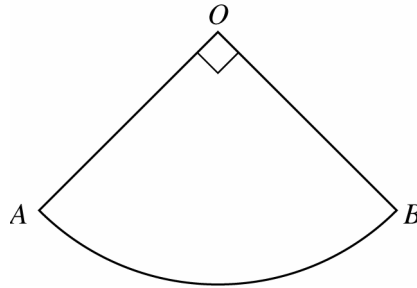

- (b) The diagram shows a simple model of a fairground swing boat. This model consists of two uniform rods OA and OB , and a seat in the form of a circular arc AB with centre O . Each rod is of mass m and of length $6a$. The seat is of mass $3m$, of radius $6a$ and angle $AOB = 90^\circ$. The rods and the seat are rigidly fixed together and the swing boat is free to rotate about a horizontal axis through O , which is perpendicular to the plane of the swing boat.
- (i) Show that the moment of inertia of the swing boat about this axis is $132ma^2$. (3 marks)
- (ii) Show that the centre of mass of the swing boat is at a distance approximately $4.09a$ from the point O . (5 marks)
- (iii) The vertical swing boat is rotated about the axis through O until OB is horizontal, with A vertically below O , and is then released from rest.

Taking the value of a to be 0.5 metres, find the greatest angular speed of the swing boat during its subsequent motion, giving your answer to three significant figures. (6 marks)

Turn over ►

- 6 The diagram shows a framework $ABCD$, which is a simple model of a wall-mounted crane. The framework consists of four light, pin-jointed rods smoothly hinged to the wall at A and D . The rods DB and BC are each one metre long and angle $ADB = 60^\circ$. The rods AB and DC are horizontal. A weight 4000 N hangs from C .

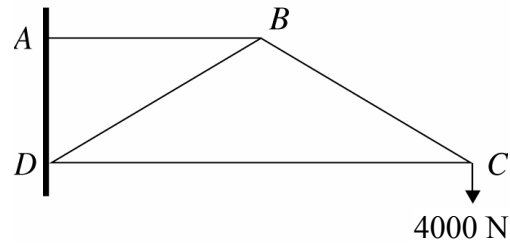

- (a) State the direction of the force which the wall exerts on the framework at A . (2 marks)
- (b) Calculate the magnitude of the force in rod BC , stating whether this force is in thrust or tension. (4 marks)
- (c) Find:
- the vertical component of the force which the wall exerts on the hinge at D ; (2 marks)
 - the horizontal component of the force which the wall exerts on the hinge at D . (3 marks)

- 7 A uniform block, in the shape of a cuboid, of mass M has square base of side $2a$, a height of $3a$, and stands on a rough horizontal surface. The coefficient of friction between the block and the surface is μ . A rope is attached to point A , the mid-point of a top edge of the block.

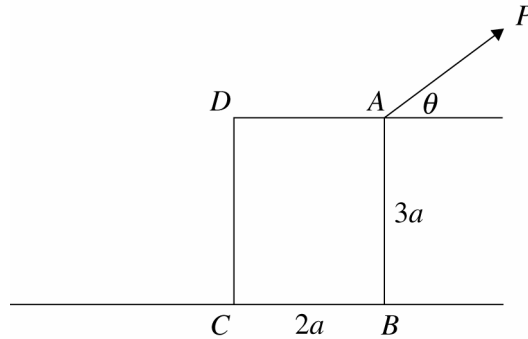

A lorry pulls the rope with force P at an angle of θ above the horizontal.

(a) Find

(i) P if the block is on the point of toppling about the edge through B; (4 marks)

(ii) P if the block is about to slide. (7 marks)

(b) Given that $\tan \theta = \frac{1}{2}$, find an inequality that μ must satisfy if the block topples before it slides.

(5 marks)

END OF QUESTIONS

MM04 Specimen

Question	Solution	Marks	Total	Comments
1(a)(i)	$\mathbf{F} = - \left\{ \begin{bmatrix} 3 \\ 6 \\ -2 \end{bmatrix} + \begin{bmatrix} 2 \\ -2 \\ -1 \end{bmatrix} \right\}$ $= -5\mathbf{i} - 4\mathbf{j} + 3\mathbf{k}$	M1 M1 A1	3	M 1 for – sign
(ii)	Magnitude is $\sqrt{5^2 + 4^2 + 3^2}$ $= 5\sqrt{2}$	M1 A1	2	
(b)	Moment of couple is moment of the forces about O $= \begin{vmatrix} i & j & k \\ 4 & -2 & 1 \\ 3 & 6 & -2 \end{vmatrix} + \begin{vmatrix} i & j & k \\ 5 & 3 & -4 \\ 2 & -2 & -1 \end{vmatrix}$ $= -2\mathbf{i} + 11\mathbf{j} + 30\mathbf{k} - 11\mathbf{i} - 3\mathbf{j} - 16\mathbf{k}$ $= -13\mathbf{i} + 8\mathbf{j} + 14\mathbf{k}$	M1 A1 A1	4	
Total			9	
2(a)	$J = 0.6 \times 5$ $= 3 \text{ kg m}^2 \text{ s}^{-1}$	M1 A1	2	
(b)	Using conservation of angular momentum $3 = 0.5 \omega$ $\omega = 6 \text{ rad s}^{-1}$	M1 A1 A1	3	
Total			5	
3 (a)	Using $G = I\ddot{\theta}$ $200 \times 0.4 = 8 \ddot{\theta}$ $\ddot{\theta} = 10$	M1 A1 A1	3	
(b)	$\dot{\theta}\ddot{\theta} = 10\dot{\theta}$ integrating $\frac{1}{2}\dot{\theta}^2 = 10\theta + c$ when $\theta = 0, \dot{\theta} = 0, c = 0$ $\dot{\theta}^2 = 20\theta$ when $\theta = 4\pi, \dot{\theta}^2 = 80\pi$ $\dot{\theta} = \sqrt{80\pi}$	M1 M1 B1 B1 A1	5	B1 for $\theta = 4\pi$
Total			8	

MM04 (cont)

Question	Solution	Marks	Total	Comments
4(a)	Using $y = a^2 - x^2$ and rotating about the x axis Distance of c of mass from the plane is $\frac{\int_0^a (a^2 x - x^3) dx}{\int_0^a (a^2 - x^2) dx}$ $= \frac{\left[\frac{a^2 x^2}{2} - \frac{x^4}{4} \right]_0^a}{\left[a^2 x - \frac{x^3}{3} \right]_0^a}$ $= \frac{\frac{a^4}{4}}{\frac{2a^3}{3}} = \frac{3}{8} a$	M1 M1 M1		Use of $\int xy^2 dx$ Use of $\int y^2 dx$
(b)	$\tan \alpha = \frac{3}{8}$ $\alpha = 20.6^\circ$	M1 A1	5 2	
	Total		7	

MM04 (cont)

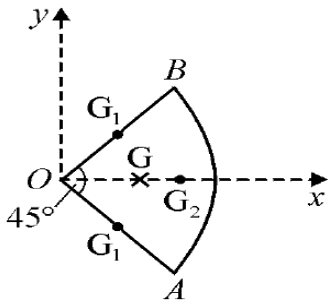
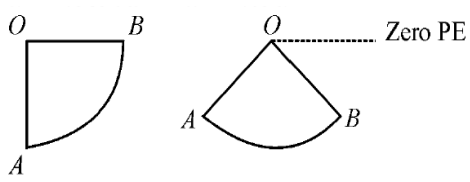
Question	Solution	Marks	Total	Comments
5 (a)	<p>M of I of element is $\frac{\delta x}{6a} mx^2$</p> <p>M of I of rod = $\sum \frac{\delta x}{6a} mx^2$</p> <p>= $\int_0^{6a} \frac{mx^2}{6a} dx$</p> <p>= $\left[\frac{m}{6a} \times \frac{x^3}{3} \right]_0^{6a} = 12 ma^2$</p>	B1 M1 A1 A1 A1	5	Use of $6a\rho$ or $\frac{\delta x}{6a}$
(b) (i)	<p>M of I = $12 ma^2 \times 2 + 3m \times (6a)^2$ = $132ma^2$</p>	M1 A1 A1	3	
(ii)	 <p>rods; distance of G_1 from $Oy = 3a \cos 45$</p> <p>arc; distance of G_2 from $Oy = \frac{6a \sin \frac{\pi}{4}}{\frac{\pi}{4}} = \frac{24a}{\sqrt{2\pi}}$</p> <p>Moments about Oy $5m\bar{x} = 2m \frac{3a}{\sqrt{2}} + 2m \frac{24a}{\sqrt{2\pi}}$ $\bar{x} = 4.09a$</p>	B1 B1 M1 A1 A1	5	
(iii)	 <p>$-4.09 a \cos 45 \times 5mg = -4.09 a \times 5mg +$ $\frac{1}{2} \times 132 ma^2 \omega^2$</p> <p>$\omega = 1.33 \text{ rad s}^{-1}$</p>	M1 A1 M1 A1 M1 A1	6	
Total			19	

MM04 (cont)

Question	Solution	Marks	Total	Comments
6				
(a)	Force at A on the frame is horizontal in the direction BA Force at A on the frame is horizontal in the direction BA	B1 B1	2	
(b)	Resolving vertically at C $T_2 \cos 60 = 4\,000$ $T_2 = 8\,000\text{N}$ BC is in tension	M1 A1 A1 A1	4	
(c)(i)	Resolving vertically for the whole framework $Y = 4000$	M1 A1	2	
(ii)	Moments about A for whole framework $X \times 1 \cos 60 = 4000 \times 2 \sin 60$ $\frac{X}{2} = \frac{2\sqrt{3}}{2} \times 4000$ $X = 8000\sqrt{3}$ or 13900	M1 A1 A1	3	
Total			11	
7(a)	At point of toppling Taking moments about B $Mga = P \cos \theta \cdot 3a$ $P = \frac{Mg}{3 \cos \theta}$	M1 M1 A1 A1	4	
(b)	At point of sliding Vertically; $R = Mg - P \sin \theta$ Horizontally; $F = P \cos \theta$ $F = \mu R$ $\mu Mg - \mu P \sin \theta = P \cos \theta$ $P = \frac{\mu Mg}{\cos \theta + \mu \sin \theta}$	M1 A1 M1 A1 B1 M1 A1	7	
(c)	If topples before it slides $\frac{Mg}{3 \cos \theta} < \frac{\mu Mg}{\cos \theta + \mu \sin \theta}$ $Mg (1 + \mu \tan \theta) < 3\mu Mg$ $1 + \frac{1}{2} \mu < 3 \mu$ $\mu > \frac{2}{5}$	M1 M1 A1 A1 A1	5	
Total			16	
TOTAL			75	

MATHEMATICS
Unit Mechanics 5

MM05

In addition to this paper you will require:

- an 8-page answer book;
 - the AQA booklet of formulae and statistical tables.
- You may use a graphics calculator.

Time allowed: 1 hour 30 minutes

Instructions

- Use blue or black ink or ball-point pen. Pencil should only be used for drawing.
- Write the information required on the front of your answer book. The *Examining Body* for this paper is AQA. The *Paper Reference* is MM05.
- Answer **all** questions.
- Take $g = 9.8 \text{ m s}^{-2}$ unless stated otherwise.
- All necessary working should be shown; otherwise marks for method may be lost.
- The **final** answer to questions requiring the use of tables or calculators should normally be given to three significant figures.

Information

- The maximum mark for this paper is 75.
- Mark allocations are shown in brackets.

Advice

- Unless stated otherwise, formulae may be quoted, without proof, from the booklet.

Answer **all** questions.

- 1 The beam of a search light shines a spot of light on a wall. The spot moves, with simple harmonic motion, between two points that are 20 metres apart. It takes 2 seconds to move from one point to the other.

Find:

- (a) the maximum speed of the spot; *(3 marks)*
(b) the maximum acceleration of the spot. *(2 marks)*

- 2 A simple pendulum consists of a particle, of mass m , fixed to one end of a light, inextensible string of length l . The other end of the string is fixed. The angle between the pendulum and the vertical is θ at time t .

- (a) Prove that, for small angles of oscillation,

$$\frac{d^2\theta}{dt^2} = -\frac{g}{l}\theta \quad (4 \text{ marks})$$

- (b) A simple pendulum has length 0.2 metres. The pendulum is released from rest with the string taut and at an angle of $\frac{\pi}{100}$ to the vertical.

- (i) Given that $\theta = A \cos(\omega t + \alpha)$, write down the values of A , ω and α . *(4 marks)*
(ii) Using the SHM equations, show that the maximum speed of the base of the pendulum in the subsequent motion is 0.014π . *(3 marks)*
(iii) Find the time taken for the pendulum to swing through an angle of $\frac{\pi}{200}$ from its initial position. *(4 marks)*

3 A particle, of mass m , is moving along a smooth wire that is fixed in the plane. With point O as the origin and the line Ox as the initial line, the polar equation of the wire is $r = ae^{2\theta}$. The particle moves with a constant angular velocity of 4. The resultant force on the particle is F . At time $t = 0$, the particle is at the point with polar co-ordinates $(a, 0)$.

- (a) Find the transverse and radial components of the acceleration of the particle as a function of t .

(10 marks)

- (b) Show that the magnitude of the force F , at time t , which keeps the angular velocity of the particle constant is $80mae^{8t}$.

(4 marks)

4 A rocket of initial mass 9000 kg is launched from a space station where gravity can be ignored. At time t seconds after the launch, the mass of the rocket is m kg and it is travelling at v m s⁻¹. The burnt fuel is ejected at 720 m s⁻¹ relative to the rocket and at a constant rate of 150 kg s⁻¹.

- (a) Use the principle of conservation of linear momentum to show that

$$\frac{dv}{dt} = \frac{720}{60 - t}$$

(7 marks)

- (b) Given that the initial mass of fuel is 6300 kg, find the maximum acceleration of the rocket.

(3 marks)

TURN OVER FOR THE NEXT QUESTION

Turn over ►

5 A light elastic string has natural length l and stiffness $\frac{2mg}{l}$. One end of the string is fixed and its other end is attached to a particle of mass m which hangs in equilibrium.

(a) Find the equilibrium extension of the string. *(2 marks)*

(b) The particle is then pulled vertically downwards for a distance $\frac{l}{2}$ and released from rest.

The resulting motion of the particle is subject to a resistance of magnitude $2mv\sqrt{\frac{g}{l}}$, where v is the speed of the particle at time t .

(i) At time t , the particle is at a displacement x from its equilibrium position. Show that x satisfies the differential equation

$$\frac{d^2x}{dt^2} + 2\sqrt{\frac{g}{l}} \frac{dx}{dt} + 2\frac{g}{l}x = 0$$

(4 marks)

(ii) Find an expression for x in terms of g , l and t .

(9 marks)

(iii) Is the damping of the motion of the particle light, critical or heavy?

Give a reason for your answer.

(2 marks)

- 6 A smooth circular wire is fixed in a vertical plane. The radius of the circle is a and its centre is O . A ring, P , of mass $3m$ is free to move on the wire and is shown at P on the diagram.

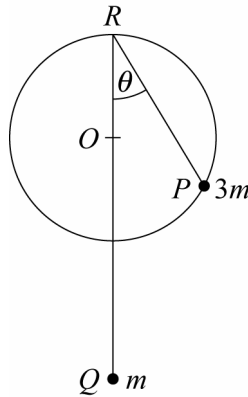

A light inextensible string of length l , where l is greater than $4a$, is attached to the ring and passes over a small smooth pulley at R , the highest point of the wire.

A particle of mass m is attached to the other end of the string at Q .

- (a) When PR makes an angle θ with the vertical, show that the total potential energy, V , of the system is given by:

$$V = 2mgac\cos\theta (1 - 3\cos\theta) + c$$

where c is a constant.

(5 marks)

- (b) (i) Show that the system is in equilibrium when $\theta = \cos^{-1} \frac{1}{6}$.

(4 marks)

- (ii) Write down the other value of θ in the range $0 \leq \theta \leq \frac{\pi}{2}$ for which the system is in equilibrium.

(1 mark)

- (c) Determine whether, when $\theta = \cos^{-1} \frac{1}{6}$, the system is in stable or unstable equilibrium.

(4 marks)

END OF QUESTIONS

MM05 Specimen

Question	Solution	Marks	Total	Comments
1 (a)	$4 = \frac{2\pi}{\omega}$ $\omega = \frac{\pi}{2}$ $v_{\max} = 10 \times \frac{\pi}{2}$ $= 5\pi = 15.7 \text{ ms}^{-1}$	B1 M1 A1	3	
(b)	$a_{\max} = 10\left(\frac{\pi}{2}\right)^2$ $= 24.7 \text{ ms}^{-2}$	M1 A1	2	
Total			5	
2 (a)	Using transverse component of acceleration is $r \frac{d^2\theta}{dt^2}$ $ml \frac{d^2\theta}{dt^2} = -mg \sin \theta$ $\frac{d^2\theta}{dt^2} = -\frac{g \sin \theta}{l}$ For small angles of θ , $\sin \theta \approx \theta$ $\frac{d^2\theta}{dt^2} = -\frac{g\theta}{l}$	B1 M1 B1 A1	4	
(b)(i)	$A = \frac{\pi}{100}$ $\omega = \sqrt{\frac{g}{l}}$	B1 M1		
(ii)	$= \sqrt{\frac{9.8}{0.2}} = 7$ $\alpha = 0$	A1 A1	4	
(iii)	maximum speed is ωa $= 0.7 \times 0.2 \times \frac{\pi}{100}$ $= 0.014 \pi$	M1 A1 A1	3	
	When $\theta = \frac{\pi}{200}$, $\frac{1}{2} = \cos \sqrt{\frac{g}{l}} t$ $\frac{\pi}{3} = \sqrt{\frac{9.8}{0.2}} t = 7t$ $t = \frac{\pi}{21}$	M1A1 A1 A1	4	
Total			15	

MM05 (cont)

Question	Solution	Marks	Total	Comments
3 (a)	$r = a e^{2\theta}$ $\dot{r} = 2ae^{2\theta} \dot{\theta}$ $\ddot{r} = 4ae^{2\theta} \dot{\theta}^2$ <p style="text-align: center;">since $\ddot{\theta} = 0$</p> $\dot{r} = 8ae^{2\theta}$ $\ddot{r} = 64ae^{2\theta}$ Since $\dot{\theta}$ is a constant, $\theta = 4t$ and $\theta = 0$ when $t = 0$ Transverse acceleration is $2\dot{r}\dot{\theta} + r\ddot{\theta}$ $= 64ae^{8t}$ Radial acceleration is $\ddot{r} - r\dot{\theta}^2$ $= 48ae^{8t}$	M1 M1 B1 A1 A1 B1 M1 A1 M1 A1	10	B1 for $\ddot{\theta} = 0$
(b)	Using $F = ma$, $\mathbf{F} = 64mae^{8t} \hat{r} + 48mae^{8t} \hat{\theta}$ Magnitude is $\{(64mae^{8t})^2 + (48mae^{8t})^2\}^{1/2}$ $= 80mae^{8t}$	M1 A1 M1 A1	4	
Total			14	

MM05 (cont)

Question	Solution	Marks	Total	Comments
4(a)	<p>Initial $m \rightarrow v$</p> <p>Final $m + \delta m \quad -\delta m$ $\rightarrow v + \delta v \quad \rightarrow v - 600$</p> <p>Conservation of linear momentum $mv = (m + \delta m)(v + \delta v) - \delta m(v - 720)$ $mv = mv + v\delta m + m\delta v - v\delta m + 720\delta m$ (to first order of δ terms) $0 = v \frac{dm}{dt} + m \frac{dv}{dt} - v \frac{dm}{dt} + 720 \frac{dm}{dt}$</p> <p>$\frac{dm}{dt} = 150$ $m = 9000 - 150t$</p> <p>$(9000 - 150t) \frac{dv}{dt} = 720 \times 150$ $\frac{dv}{dt} = \frac{720}{60 - t}$</p>	<p>M1A1</p> <p>M1</p> <p>B1</p> <p>B1</p> <p>M1</p> <p>A1</p>	<p>7</p>	
(b)	<p>Max acc is max of $\frac{720}{60 - t}$</p> <p>Max $t = \frac{6300}{150} = 42$</p> <p>$\therefore$ max acc is $\frac{720}{18} = 40 \text{ m s}^{-2}$</p>	<p>M1</p> <p>B1</p> <p>A1</p>	<p>3</p>	
	Total		10	

MM05 (cont)

Question	Solution	Marks	Total	Comments
5(a)	In equilibrium: $T_E = \frac{2mg}{l} \times e = mg$ $e = \frac{l}{2}$	M1 A1	2	
(b)	In general position: $T = \frac{2mg}{l} (x + \frac{l}{2})$ Using $F = ma$ $m \frac{d^2x}{dt^2} =$ $mg - \frac{2mg}{l} (x + \frac{l}{2}) - 2\sqrt{\frac{g}{l}} mv$ $\frac{d^2x}{dt^2} + 2\sqrt{\frac{g}{l}} \frac{dx}{dt} + 2\frac{g}{l} x = 0$	M1 M1 A1 A1	4	
(c)	Auxiliary equation $\lambda^2 + 2\sqrt{\frac{g}{l}} \lambda + 2\frac{g}{l} x = 0$ $\lambda = -\sqrt{\frac{g}{l}} \pm \sqrt{\frac{g}{l}} i$ $x = e^{-\sqrt{\frac{g}{l}} t} (A \cos \sqrt{\frac{g}{l}} t + B \sin \sqrt{\frac{g}{l}} t)$ At $t = 0$, $x = \frac{1}{2} l$ and $\frac{dx}{dt} = 0$ $A = \frac{1}{2} l$ $\frac{dx}{dt} = -\sqrt{\frac{g}{l}} e^{-\sqrt{\frac{g}{l}} t} (A \cos \sqrt{\frac{g}{l}} t +$ $B \sin \sqrt{\frac{g}{l}} t) + e^{-\sqrt{\frac{g}{l}} t} (-\sqrt{\frac{g}{l}} A \sin \sqrt{\frac{g}{l}} t +$ $B \sqrt{\frac{g}{l}} \cos \sqrt{\frac{g}{l}} t)$ $B = \frac{1}{2} l$ $X = \frac{1}{2} e^{-\sqrt{\frac{g}{l}} t} (\cos \sqrt{\frac{g}{l}} t + \sin \sqrt{\frac{g}{l}} t)$	M1 A1 M1A1 M1 A1 A1 A1 A1	9	
(d)	Damping motion is light damping since the particle oscillates with its amplitude reducing to zero.	B1 B1	2	
Total			17	

MM05 (cont)

Question	Solution	Marks	Total	Comments
6(a)	$PR = 2a \cos \theta$ Potential energy, below R, of 3m mass is $- 3mg \cdot 2a \cos^2 \theta$ $= - 6mga \cos^2 \theta$ Potential energy, below R, of m mass is $- mg (l - 2a \cos \theta)$ Total PE is $- 6mga \cos^2 \theta - mg (l - 2a \cos \theta) + c$ $V = 2mg \cos \theta (1 - 3 \cos \theta) - mgl + c$ $V = 2mg \cos \theta (1 - 3 \cos \theta) + c$	B1 M1 A1 M1 A1	5	One correct
(b)(i)	$\frac{dV}{d\theta} =$ $-2mg \sin \theta (1 - 3 \cos \theta) + 3 \sin \theta \cdot 2mg \cos \theta$ $= 12mg \sin \theta \cos \theta - 2mg \sin \theta$ $= 2mg \sin \theta (6 \cos \theta - 1)$ $= 0$ when $\sin \theta = 0$ or $\cos \theta = \frac{1}{6}$ \therefore system is in equilibrium when $\theta = \cos^{-1} \frac{1}{6}$	M1 A1 M1 A1	4	
(ii)	$\theta = 0$	B1	1	
(c)	$\frac{d^2V}{d\theta^2} = 2mga \cos \theta (6 \cos \theta - 1)$ $- 6 \sin \theta \cdot 2mga \sin \theta$ $= 12mga (\cos^2 \theta - \sin^2 \theta) - 2mga \cos \theta$ When $\theta = \cos^{-1} \frac{1}{6}$, $\frac{d^2V}{d\theta^2} = - \frac{35}{3} mga$ This is negative \Rightarrow maximum PE Position is unstable equilibrium	M1 A1 A1 A1	4	or $\frac{dV}{d\theta} > 0$ when $\theta < \cos^{-1} \frac{1}{6}$ M1 A1 $\frac{dV}{d\theta} < 0$ when $\theta > \cos^{-1} \frac{1}{6}$ A1 Maximum P.E. Position is unstable equilibrium A1
	Total		14	
	TOTAL		75	