

Surname					Other Names				
Centre Number					Candidate Number				
Candidate Signature									

Leave blank

General Certificate of Education
January 2004
Advanced Level Examination



BIOLOGY/HUMAN BIOLOGY (SPECIFICATION A) BYA5
Unit 5 Inheritance, Evolution and Ecosystems

Thursday 22 January 2004 Morning Session

<p>No additional materials are required. You may use a calculator.</p>

Time allowed: 1 hour 30 minutes

Instructions

- Use blue or black ink or ball-point pen.
- Fill in the boxes at the top of this page.
- Answer **all** questions in the spaces provided. All working must be shown.
- Do all rough work in this book. Cross through any work you do not want marked.

Information

- The maximum mark for this paper is 75.
- Mark allocations are shown in brackets.
- You will be assessed on your ability to use an appropriate form and style of writing, to organise relevant information clearly and coherently, and to use specialist vocabulary, where appropriate.
- The degree of legibility of your handwriting and the level of accuracy of your spelling, punctuation and grammar will also be taken into account.

For Examiner's Use			
Number	Mark	Number	Mark
1			
2			
3			
4			
5			
6			
7			
8			
9			
Total (Column 1)	→		
Total (Column 2)	→		
TOTAL			
Examiner's Initials			

Answer **all** questions in the spaces provided.

1 Living organisms are classified into five kingdoms. Use the following key to identify each of the kingdoms **A, B, C, D** and **E**.

Key:

- 1 Cells have several linear DNA molecules which are separated from the cytoplasm by a nuclear envelope go to 2
 Cells have circular DNA molecules and no nuclear envelope separating them from the cytoplasm Kingdom **A**
- 2 Body is usually composed of branching thread-like hyphae Kingdom **B**
 Body is not composed of hyphae go to 3
- 3 Contains both single-celled organisms and multicellular organisms Kingdom **C**
 Contains only multicellular organisms go to 4
- 4 Autotrophic, non-motile organisms whose cells possess a wall containing cellulose Kingdom **D**
 Heterotrophic, usually motile organisms whose cells do not possess a wall Kingdom **E**

Kingdom **A**

Kingdom **B**

Kingdom **C**

Kingdom **D**

Kingdom **E**

(5 marks)

5

TURN OVER FOR THE NEXT QUESTION

Turn over

2 Tropical rainforests are being cut down at a rapid rate. It is generally agreed among biologists that conservation of the remaining forests is necessary.

(a) What is meant by *conservation*?

.....
.....

(1 mark)

(b) Give **three** reasons why tropical rainforests should be conserved.

1
.....

2
.....

3
.....

(3 marks)



3 The diagram shows the structure of a chloroplast.

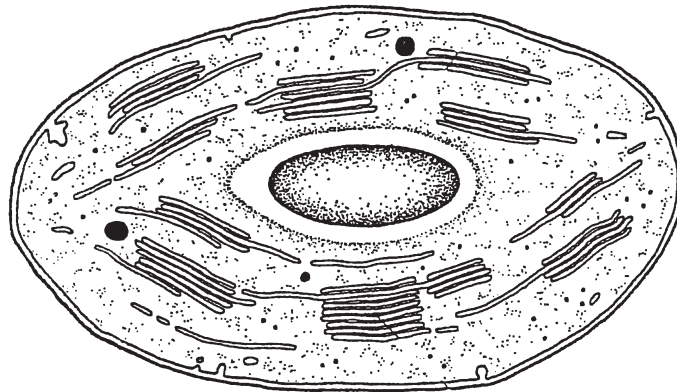

(a) Label the diagram with an **X** to show where the light-dependent reactions take place and with a **Y** to show where the light-independent reactions take place.

(1 mark)

(b) The photolysis of water is an important part of the process of photosynthesis. Describe what happens in the photolysis of water.

.....
.....
.....
.....

(2 marks)

(c) ATP and reduced NADP are two products of the light-dependent reactions. Describe **one** function of **each** of these substances in the light-independent reactions.

ATP

.....

Reduced NADP

.....

(2 marks)

Turn over ►

- 4 The diagram shows the transfer of energy through a cow. The figures are in $\text{kJ} \times 10^6 \text{ year}^{-1}$.

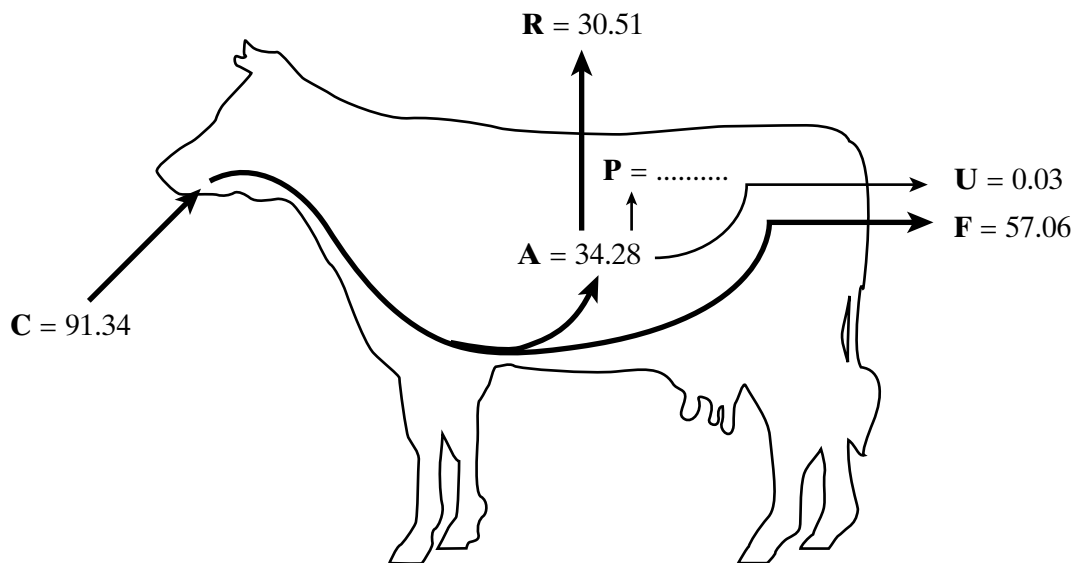

Key: **A** = energy absorbed from the gut
C = energy consumed in food
F = energy lost in faeces
P = energy used in production of new tissue
R = energy lost by respiration
U = energy lost in urine

- (a) (i) Complete the following equation for the energy used in the production of new tissue. Use only the letters **C**, **F**, **R** and **U**.

P =
 (1 mark)

- (ii) Calculate the value of **P**.

P = $\text{kJ} \times 10^6 \text{ year}^{-1}$
 (1 mark)

- (b) It has been estimated that an area of 8100m^2 of grassland is needed to keep one cow. The productivity of grass is $21\,135\text{kJm}^{-2}\text{year}^{-1}$. What percentage of the energy in the grass is used in the production of new tissue in one cow? Show your working.

Answer %
(2 marks)

- (c) Keeping cattle indoors, in barns, leads to a higher efficiency of energy transfer. Explain why.

.....

.....

(1 mark)

5

TURN OVER FOR THE NEXT QUESTION

Turn over ►

- 5 Duchenne muscular dystrophy is a sex-linked inherited condition which causes degeneration of muscle tissue. It is caused by a recessive allele. The diagram shows the inheritance of muscular dystrophy in one family.

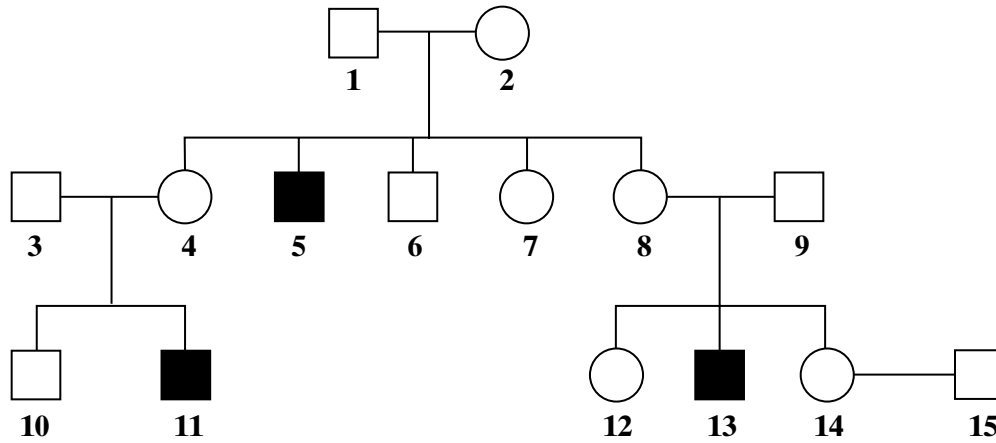

Key:



= male with muscular dystrophy



= unaffected male



= female with muscular dystrophy



= unaffected female

- (a) Give evidence from the diagram which suggests that muscular dystrophy is

(i) sex-linked;

.....
(1 mark)

(ii) caused by a recessive allele.

.....
(1 mark)

(b) Using the following symbols,

X^D = an X chromosome carrying the normal allele

X^d = an X chromosome carrying the allele for muscular dystrophy

Y = a Y chromosome

give **all** the possible genotypes of each of the following persons.

5

6

7

8

(2 marks)

(c) A blood test shows that person **14** is a carrier of muscular dystrophy. Person **15** has recently married person **14** but as yet they have had no children. What is the probability that their first child will be a male who develops muscular dystrophy?

.....

(1 mark)

5

TURN OVER FOR THE NEXT QUESTION

Turn over 

- 6 The soybean is a leguminous plant. The effect of nitrate fertiliser and of the nitrogen-fixing bacterium, *Rhizobium*, on the growth of soybeans and on the growth of one species of grass was investigated. The soybeans and grass seeds were sown together in pots of soil in five different proportions. They were then treated with different combinations of nitrate fertiliser and *Rhizobium* bacteria, as follows:

- Batch **A**: no *Rhizobium*, no nitrate fertiliser
 Batch **B**: *Rhizobium* added, no nitrate fertiliser
 Batch **C**: no *Rhizobium*, nitrate fertiliser added
 Batch **D**: *Rhizobium* added, nitrate fertiliser added

The dry masses of the soybean plants and of the grass were determined after 6 months of growth. The results are shown in the graphs.

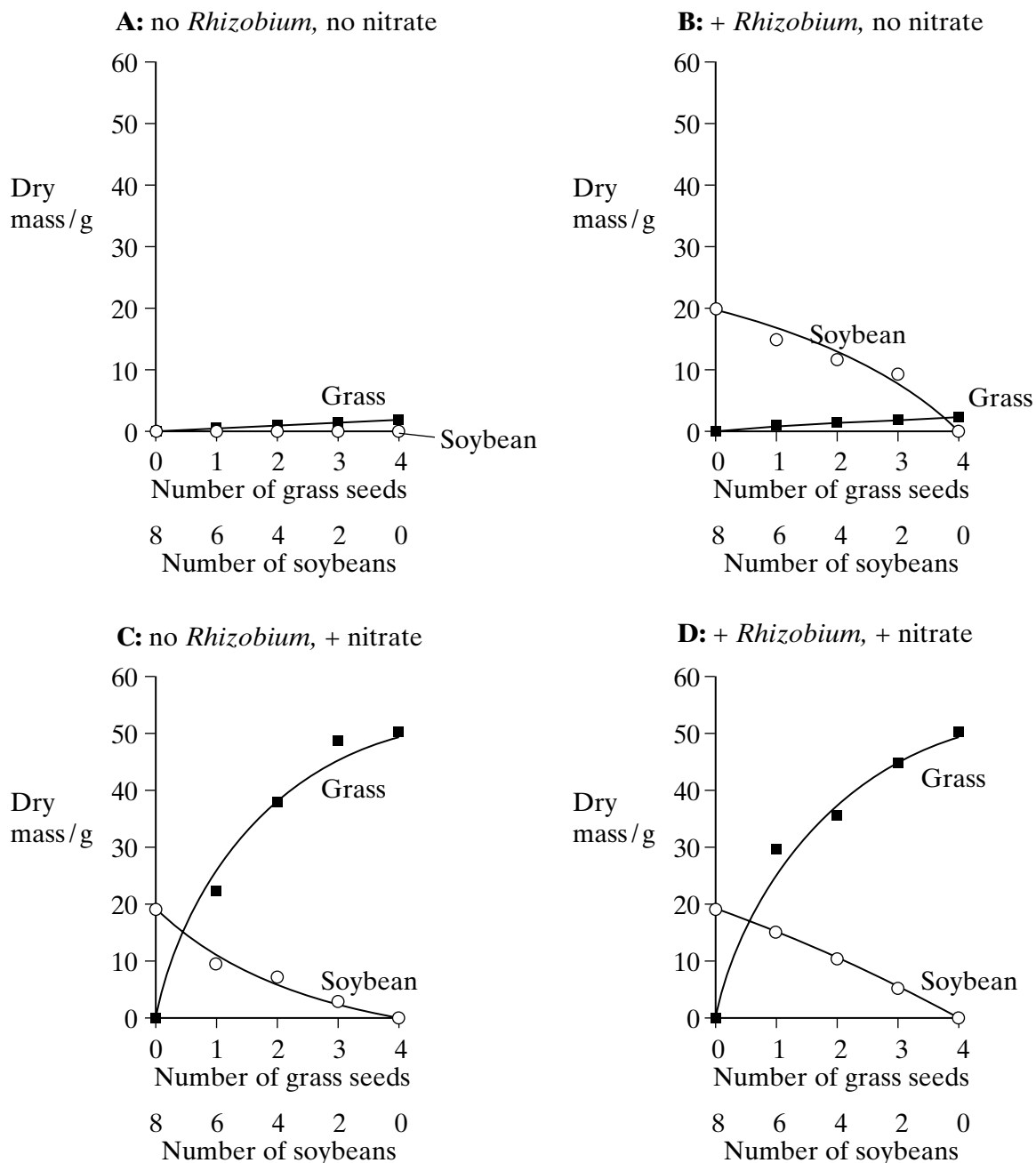

(a) Did *Rhizobium* bacteria have any effect on the growth of the grass? Give evidence from graphs C and D for your answer.

.....
.....

(1 mark)

(b) Can the soybean make use of nitrogen supplied in the form of nitrate fertiliser? Give evidence from the graphs for your answer.

.....
.....
.....
.....

(2 marks)

(c) Describe and explain the effect of *Rhizobium* bacteria on the growth of soybeans.

.....
.....
.....
.....
.....
.....
.....
.....
.....

(3 marks)

6

TURN OVER FOR THE NEXT QUESTION

Turn over 

- 7 Parts of the sea shore form a very hostile environment for living organisms. Twice each day the incoming and outgoing tides alternately cover the organisms on the sea shore with water and then leave them exposed. The force of the waves could also dislodge any organisms that were not firmly attached.

The diagram shows a section through a rocky shore. Two sites were studied: site **A** was on the upper shore and site **B** on the lower shore.

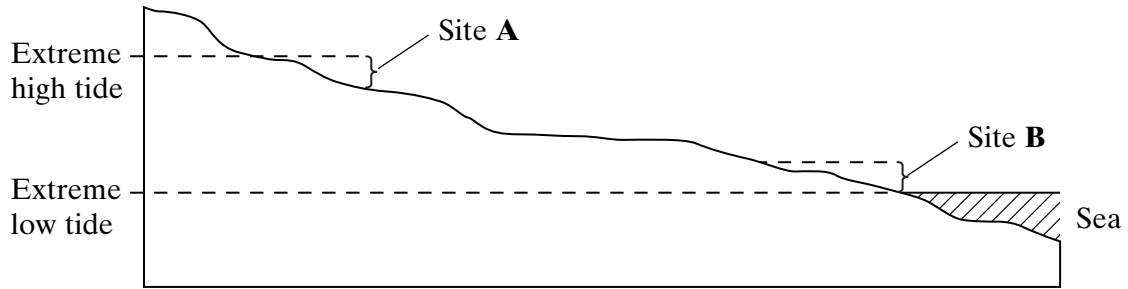

The table shows the seaweeds that were found growing at sites **A** and **B**.

Site A: upper shore	Mean number per m ²	Site B: lower shore	Mean number per m ²
<i>Ascophyllum nodosum</i>	2	<i>Corallina officinalis</i>	31
<i>Fucus spiralis</i>	10	<i>Fucus serratus</i>	8
<i>Fucus vesiculosus</i>	4	<i>Laminaria digitata</i>	15
<i>Pelvetia canaliculata</i>	6	<i>Laminaria hyperborea</i>	3
		<i>Laminaria saccharina</i>	6
		<i>Laurencia pinnatifida</i>	18
		<i>Palmaria palmata</i>	6
Index of diversity		Index of diversity	4.77

(a) (i) Use the formula
$$d = \frac{N(N - 1)}{\sum n(n - 1)}$$

where **d** = index of diversity
N = total number of organisms of all species
n = total number of organisms of a particular species

to calculate the index of diversity for the seaweeds growing at site **A**.
 Show your working.

Index of diversity at site **A** =
 (2 marks)

- (ii) Give **one** advantage of calculating the index of diversity rather than just recording the number of species present.

.....

.....

(1 mark)

- (b) Availability of water is one abiotic factor which determines the distribution of seaweeds. The graph shows loss in mass due to water evaporation for two of the seaweed species. The two seaweeds belong to the same genus but one was found only on the upper shore and the other only on the lower shore.

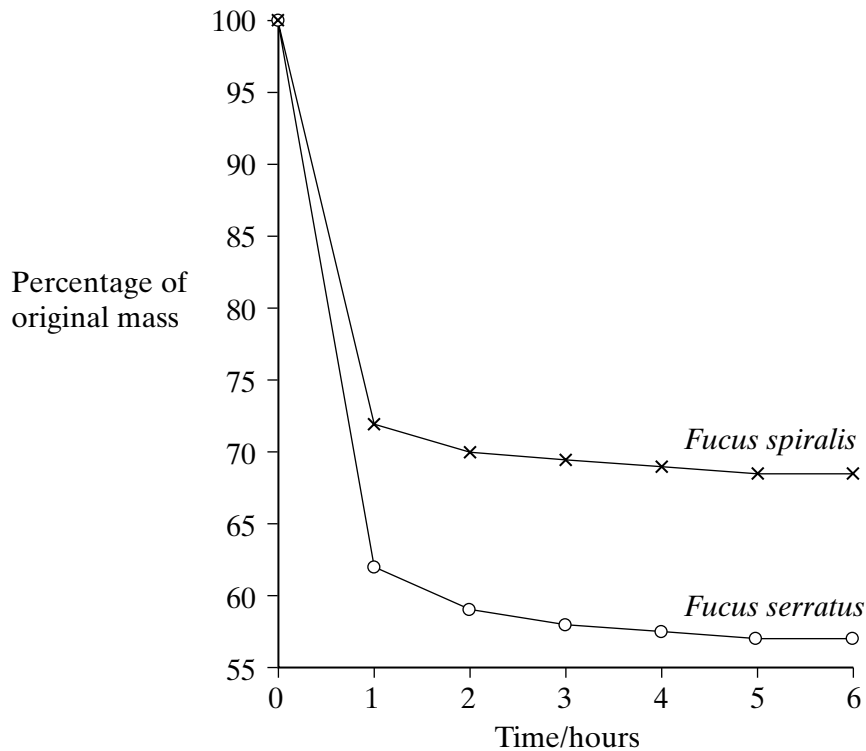

- (i) Explain how the results shown in the graph relate to the distribution of these two seaweeds on the sea shore.

.....

.....

.....

.....

.....

.....

(3 marks)

QUESTION 7 CONTINUES ON THE NEXT PAGE

Turn over ▶

- (ii) Apart from the availability of water, describe and explain how any **two** other abiotic factors might have caused differences in the seaweeds growing at sites **A** and **B**.

Factor

Explanation

.....

Factor

Explanation

.....

(4 marks)

- (c) Biotic factors will have a greater effect on the composition of the community at site **B** than at site **A**.

- (i) What is meant by a *community*?

.....

.....

(1 mark)

- (ii) Explain why biotic factors will have a greater effect at site **B**.

.....

.....

.....

.....

.....

.....

.....

.....

.....

.....

(4 marks)

8 The diagram gives an outline of the process of aerobic respiration.

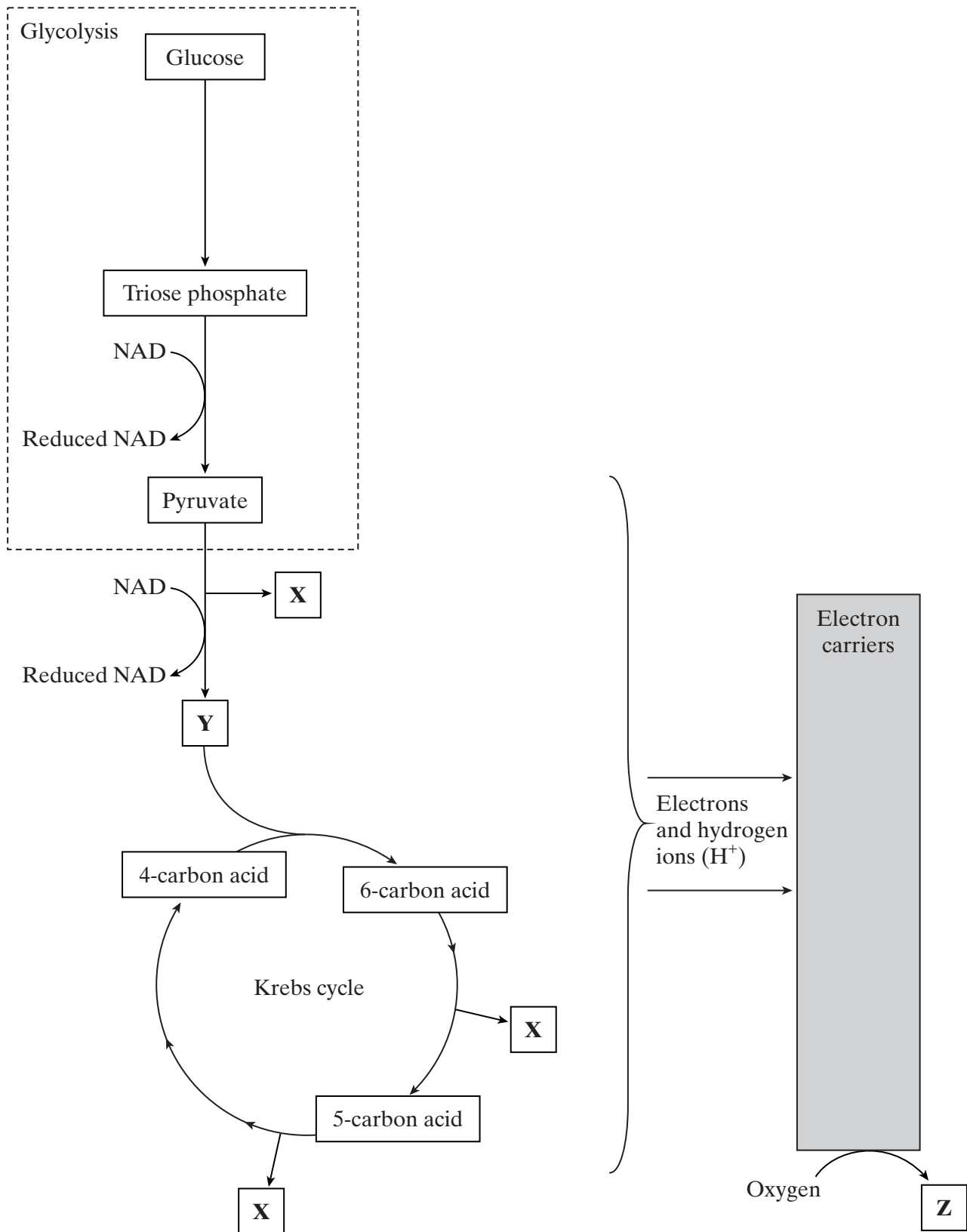

(a) Name substances **X**, **Y** and **Z**.

X

Y

Z

(3 marks)

(b) Give the location of each of the following in a liver cell.

(i) Glycolysis

(ii) The Krebs cycle

(2 marks)

(c) (i) Write the letter **A** on the diagram to show **one** step where ATP is used.

(ii) Write the letter **B** on the diagram at **two** steps where ATP is produced.

(3 marks)

(d) Apart from respiration, give **three** uses of ATP in a liver cell.

1

2

3

(3 marks)

(e) Human skeletal muscle can respire both aerobically and anaerobically. Describe what happens to pyruvate in anaerobic conditions and explain why anaerobic respiration is advantageous to human skeletal muscle.

.....
.....
.....
.....
.....
.....
.....
.....
.....
.....
.....

(4 marks)

Turn over ▶

9 (a) Describe what happens to chromosomes in meiosis.

.....

.....

.....

.....

.....

.....

.....

.....

.....

.....

.....

.....

.....

.....

.....

.....

.....

.....

.....

.....

.....

.....

(6 marks)

(b) Meiosis results in genetic variation in the gametes which leads to variation in the offspring formed by sexual reproduction. Describe how meiosis causes this variation and explain the advantage of variation to the species.

.....

.....

.....

.....

.....

.....

.....

.....

.....

.....

.....

.....

.....

.....

.....

.....

.....

.....

.....

.....

.....

.....

(5 marks)

(c) An old form of wheat, emmer wheat (*Triticum turgidum*), has a diploid chromosome number of 28 ($2n = 28$). A wild wheat, einkorn wheat (*Triticum tauschii*), has a diploid chromosome number of 14 ($2n = 14$). These two species occasionally crossed and produced sterile hybrid plants. Due to an error during cell division, one of these hybrid plants formed male and female gametes with 21 chromosomes. Fusion of these gametes resulted in viable offspring. These plants were a new species, *Triticum aestivum* ($2n = 42$), our modern bread wheat.

(i) How many chromosomes would there have been in each of the cells of the hybrid plant produced by crossing *Triticum turgidum* with *Triticum tauschii*?

.....
(1 mark)

(ii) Explain why *Triticum aestivum* is fertile while the majority of hybrid plants were not.

.....
.....
.....
.....
.....
.....
.....
.....
(3 marks)

END OF QUESTIONS