

General Certificate of Education
June 2008
Advanced Level Examination



GENERAL STUDIES (SPECIFICATION A)
Unit 5 Science, Mathematics and Technology

GSA5

Thursday 5 June 2008 9.00 am to 10.30 am

For this paper you must have:

- an objective test answer sheet
- an 8-page answer book.

You may use a calculator.

Time allowed: 1 hour 30 minutes

Instructions

- Use black ink or black ball-point pen.
- Write the information required on the front of your answer book for Question 2. The *Examining Body* for this paper is AQA. The *Paper Reference* is GSA5.
- Answer **all** of Question 1 (1.1 to 1.20) using the answer sheet provided **and one** question from Questions 2.1 to 2.6 in a separate answer book.
- For each item in Question 1 there are several alternative responses. When you have selected the response which you think is the best answer to a question, mark this response on your answer sheet.
- Do all rough work in your answer book, **not** on your answer sheet.

Information

- The maximum mark for this paper is 45.
- This paper consists of **two** questions.
Question 1 contains 20 objective test questions based on a variety of exercises in spatial and mechanical relations. Each question carries 1 mark. You will not lose marks for wrong answers.
Question 2 consists of six alternative essay questions (2.1 to 2.6). 25 marks are available for your essay.

QUESTION 1

Answer **Questions 1.1** to **1.20**.

For each of **Questions 1.1** to **1.20** choose the answer represented by the letter **A**, **B**, **C** or **D** that you think best.

Crystal Models**Questions 1.1 to 1.4**

Crystalline solids can be represented by imagining atoms as spheres. Two possible configurations for a layer of spheres are shown below.

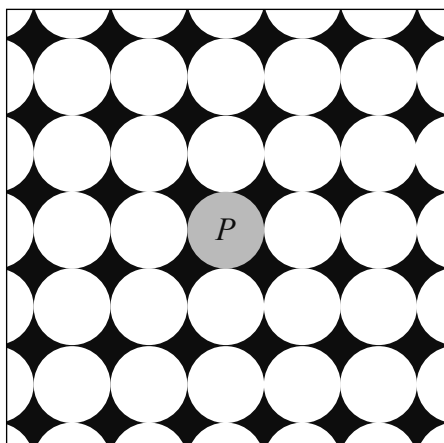
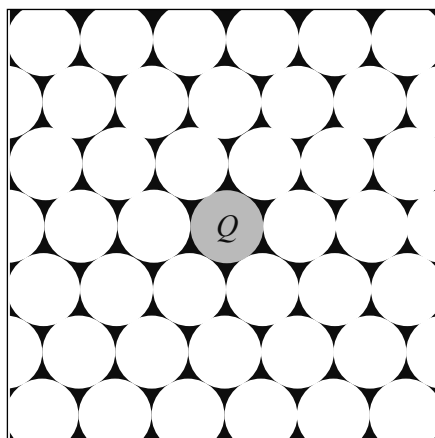
Figure 1a**Figure 1b**

Further layers can be added using the same configuration in each case. This can be done either by placing spheres directly on top of the spheres in the first layer, or by positioning them in the hollows between spheres.

1.1 A second layer of spheres is placed directly on top of the spheres shown in **Figure 1a**. How many of the spheres in this second layer touch the sphere labelled *P*?

- A** 1
- B** 2
- C** 4
- D** 8

1.2 Additional layers of spheres are placed directly above and below the spheres shown in **Figure 1a**. What is the total number of spheres now touching the sphere labelled *P*?

- A** 6
- B** 12
- C** 18
- D** 24

1.3 A second layer of spheres is placed in the hollows between the spheres shown in **Figure 1b**.

The number of spheres in this new layer touching the sphere labelled Q is

- A** 3
- B** 4
- C** 6
- D** 8

1.4 Additional layers of spheres are placed in the hollows between spheres above and below the layer shown in **Figure 1b**. What is the total number of spheres now touching the sphere labelled Q ?

- A** 3
- B** 6
- C** 9
- D** 12

Turn over for the next question

Turn over ▶

Questions 1.5 and 1.6

The three basic crystal structures are called Hexagonal Close Packed (HCP), Face Centred Cubic (FCC) and Body Centred Cubic (BCC).

Figure 2

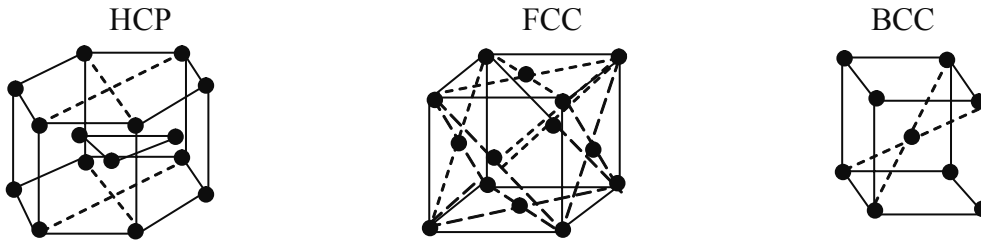

1.5 Shown below are alternative representations of the structures in **Figure 2**.

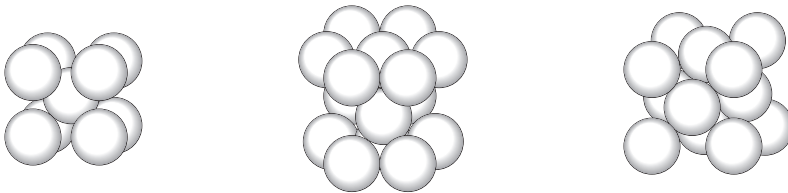

The order in which they are represented is

- A** BCC, HCP, FCC
- B** BCC, FCC, HCP
- C** FCC, HCP, BCC
- D** HCP, BCC, FCC

1.6 In the BCC arrangement of **Figure 2**, the spheres are spaced farther apart than in the other two structures. Consequently the atoms in the same layer do not touch each other. The total number of atoms touching any one atom is therefore

- A** 3
- B** 6
- C** 8
- D** 12

Mobility

- 1.7** A constant impediment for wheelchair users is getting up a step or over a kerb. One rule-of-thumb states that a powered wheelchair can climb kerbs with a height of no more than a third of the diameter of the front wheel of the wheelchair.

Which of these wheelchairs could climb a 10 cm kerb?

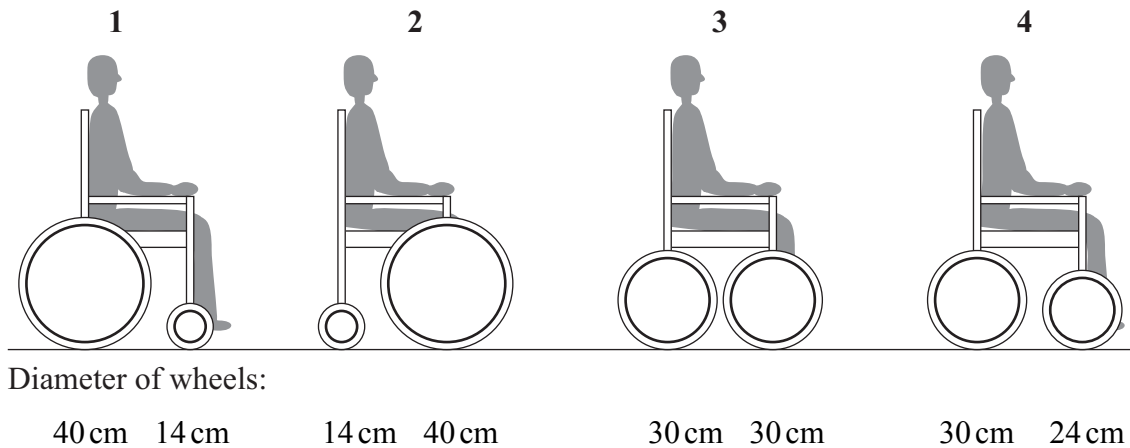

Answer

- A** if none of them could climb the kerb.
- B** if **2** and **3** only could climb the kerb.
- C** if **2**, **3** and **4** only could climb the kerb.
- D** if all could climb the kerb.

Turn over for the next question

Turn over ▶

Questions 1.8 and 1.9

Some designers have produced wheelchairs designed to climb stairs. One such prototype is shown in the diagrams below.

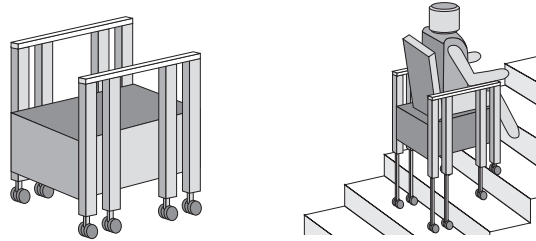

It has eight legs, the lengths of which are adjusted independently by the mechanism to enable the chair to 'walk' up steps. The forward legs in each pair (**1** and **3**) have driving wheels on the end and the rear legs in each pair (**2** and **4**) have freely rolling wheels.

1.8 These diagrams show the first two stages in climbing stairs.

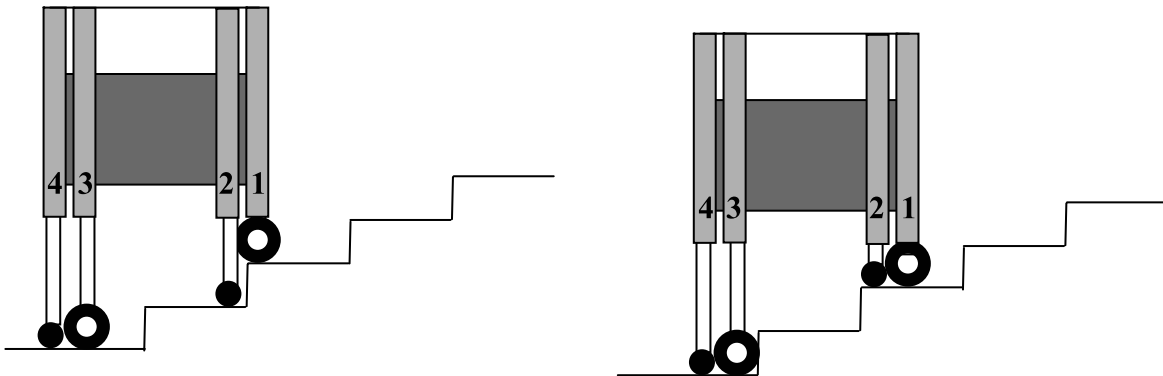

The next actions are

- A chair moves forward, then legs **1** and **3** raise.
- B legs **3** and **4** raise, then the chair moves forward.
- C chair moves forward, then leg **1** raises.
- D leg **3** raises, then the chair moves forward.

- 1.9 This diagram shows the chair at a later stage of the motion up the stairs. The next stage in the process of moving up to the next step would be that

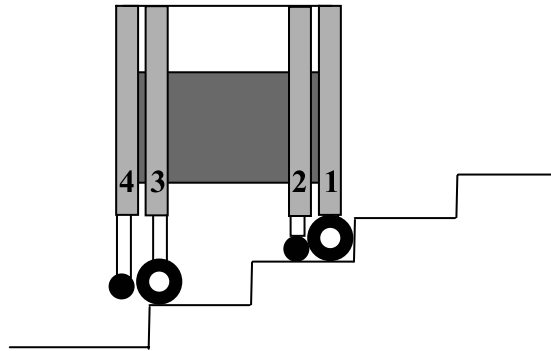

- A all four legs lengthen.
- B legs 1 and 2 lengthen.
- C leg 4 lengthens.
- D legs 3 and 4 lengthen.

Packaging

- 1.10 The net of a tetrahedron that shows an arrangement of flaps so that each edge may be glued is

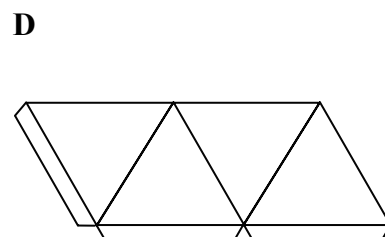
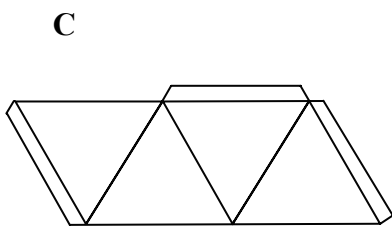
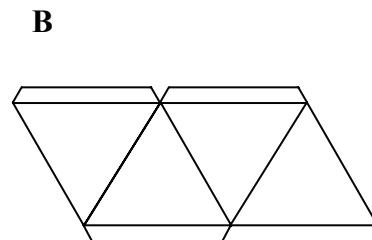
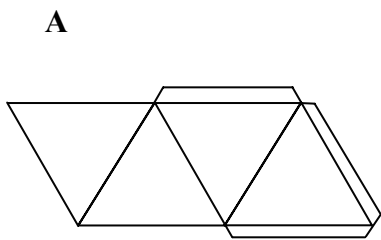

Turn over for the next question

Turn over ►

- 1.11 The tetrahedral packet shown in **Figure 3** needs to be printed so that the outside reads PURE ORANGE JUICE around the base, as shown when viewed from above.

Figure 3

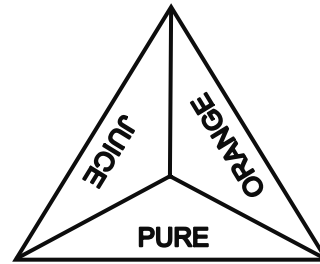

Which of the following nets can be folded to make the tetrahedral packet shown in **Figure 3**?

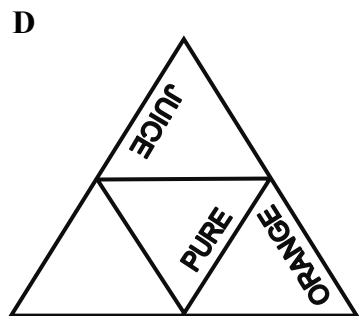
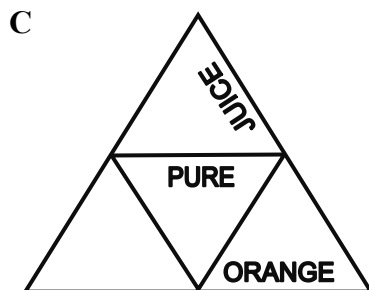
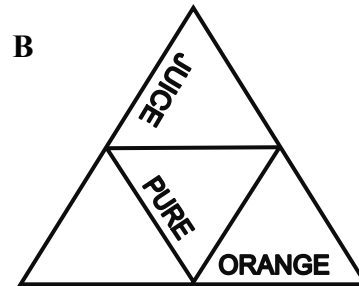
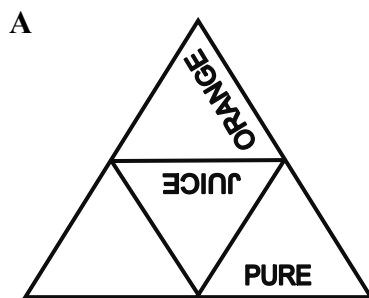

Questions 1.12 to 1.14

1.12 A chocolate bar fits into a triangular prism as shown in **Figure 4**.

Figure 4

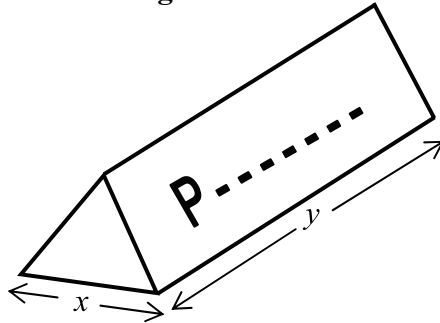

The net which would make a suitable box is

A



B

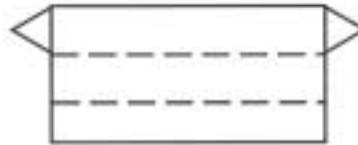

C

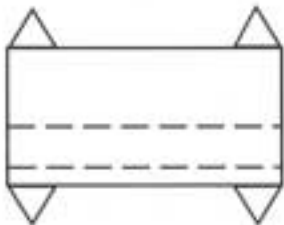

D

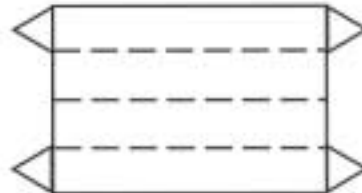

1.13 When the box is standing on its base as shown in **Figure 4** the name can be read from both sides. To do this the outside of the packet when viewed from above should look like

A

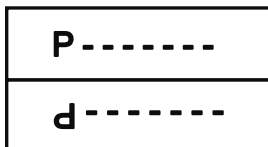

B

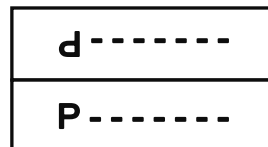

C

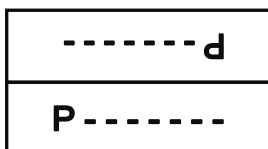

D

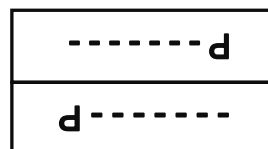

Turn over ▶

- 1.14** A special triangular prism box is made for a promotion. The box has the same length as **Figure 4** but the sides of each triangle are three times as long.

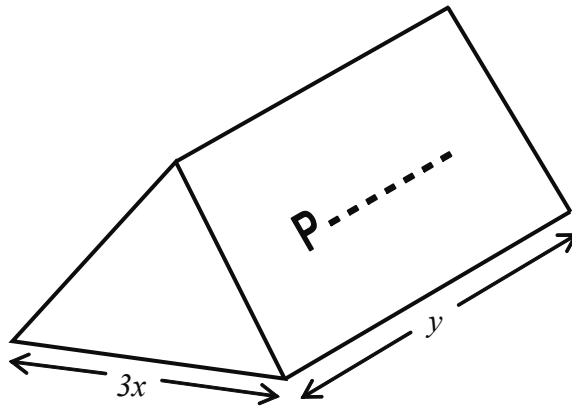

The number of original size bars that will fit into this box is

- A 3
 - B 5
 - C 6
 - D 9
- 1.15** A box of Turkish Delight is a regular hexagonal prism.

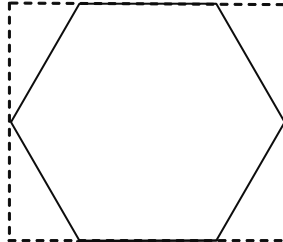

Compared with a rectangular box of the same maximum dimensions, as shown above in the plan view, the volume of the Turkish Delight box is what fraction of the volume of the rectangular box?

- A $\frac{3}{4}$
- B $\frac{5}{6}$
- C $\frac{7}{8}$
- D $\frac{9}{10}$

Pulleys

Questions 1.16 and 1.17

A system of pulleys is a simple machine for changing the direction of a force and/or gaining mechanical advantage. Mechanical advantage is the size of the load divided by the size of the applied force.

In the simplest case, a single pulley can allow a horizontal force to support or raise a load. Assuming that friction in the system is negligible, the load can be supported or raised by a force F equal to the weight W of the load. The tension T is assumed to be constant throughout the length of the rope and all pulleys and ropes are assumed to be light and smooth.

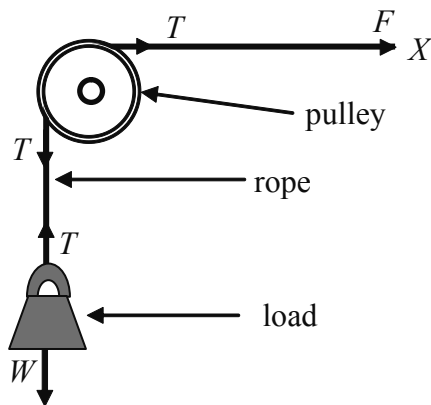

1.16 In order to raise the load by a distance h the point X must be moved to the right a distance equal to

- A $\frac{h}{2}$
- B h
- C $h\sqrt{2}$
- D $2h$

1.17 The mechanical advantage of this single pulley system is 1 because the

- A direction of the force is moved through one right angle.
- B size of the force needed to raise the load is equal to the size of the load.
- C weight of the load is equal to the distance moved by the force.
- D tension in the rope is equal throughout its length.

Turn over ►

Questions 1.18 and 1.19

In this three-pulley system, the load is suspended from a central pulley that can move vertically. The load and its pulley are maintained in equilibrium by equal forces F applied at both ends of a rope passing under the movable pulley and over two fixed pulleys.

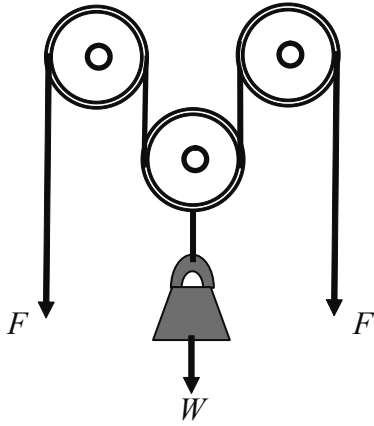

1.18 The size of each force F is

- A $\frac{1}{2}W$
- B W
- C $2W$
- D $3W$

1.19 The size of the resultant force acting on the central pulley when it is stationary is

- A 0
- B $\frac{1}{2}W$
- C W
- D $W + 2F$

- 1.20** The diagram shows a fire ladder. For each section of the ladder except the final one, a cable passes from a fixed point at the bottom of the section, over a pulley and is attached to a fixed point at the top of the next section. On the final section of the ladder, the cable is wound onto the drive pulley.

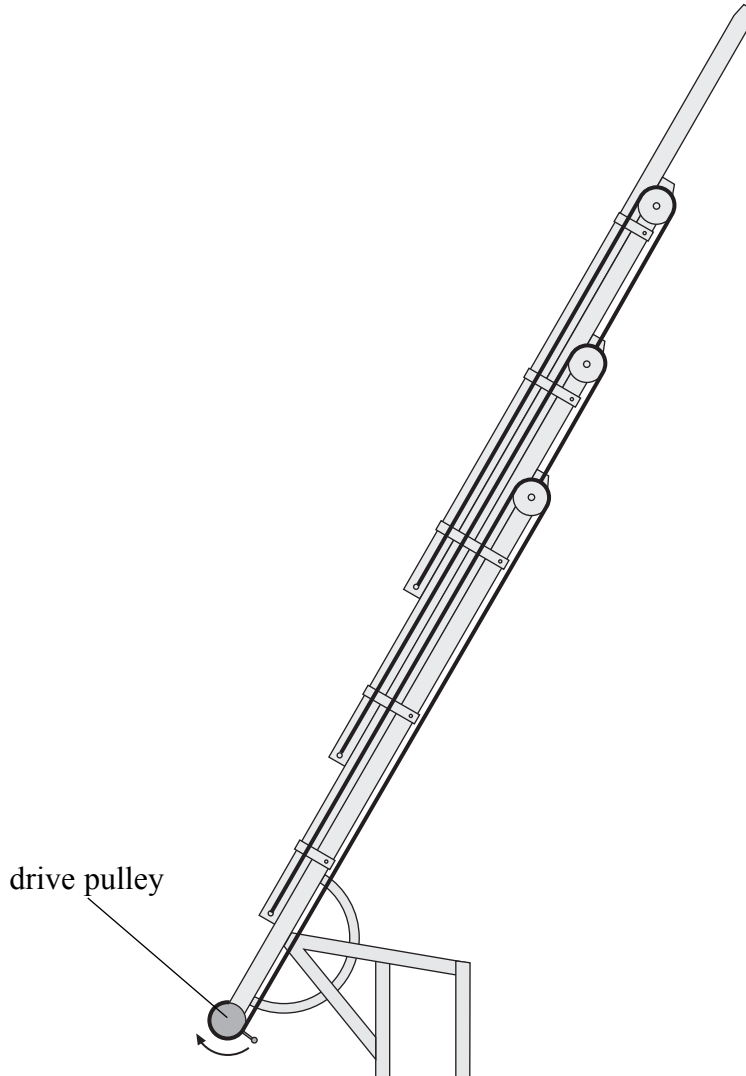

When the drive pulley is turned clockwise, the ladder

- A extends.
- B closes up.
- C becomes nearer to vertical.
- D becomes nearer to horizontal.

END OF QUESTION 1

Turn over for Question 2

Turn over ▶

QUESTION 2

Answer **one** of Questions **2.1** to **2.6**.

Each question carries 25 marks.

Answer this question in a **separate** answer book. Label this answer book **GSA5 Question 2**.

Where appropriate include relevant science and use examples to illustrate your answer.

Write your answer in continuous prose as if you are addressing the intelligent general reader. You will be marked on your ability to use good English, to organise information clearly and to use specialist vocabulary where appropriate.

- 2.1** More than one in five adults in the UK is clinically obese and the proportion is increasing. Explain the suggested causes and effects of obesity and discuss what actions might be taken by individuals and public authorities to reduce obesity.
- 2.2** Explain the nature and origin of comets and asteroids. Discuss the likely effects of an impact on the Earth, and suggest what actions might be taken to prevent such an event.
- 2.3** Developments in information and communication technologies have led to the introduction of mobile phones, PDAs and similar devices. Explain how such devices encourage the transmission of data around the globe. Assess the effects of these technologies on the collection and dissemination of news, comment and opinion.
- 2.4** Explain the importance for human beings of the ozone layer in the Earth's atmosphere, and the changes in it caused by human activity in recent decades. Discuss the benefits and dangers of exposure to sunlight for human beings.
- 2.5** Explain the main principles and applications of genetic testing. Discuss ethical issues that might be encountered in undertaking genetic testing.
- 2.6** Explain what is meant by environmental sustainability. Discuss the measures a household in Britain might take in order to develop an environmentally-friendly lifestyle.

END OF QUESTIONS

There are no questions printed on this page

There are no questions printed on this page

ACKNOWLEDGEMENT OF COPYRIGHT-HOLDERS AND PUBLISHERS

Permission to reproduce all copyright material has been applied for. In some cases efforts to contact copyright-holders have been unsuccessful and AQA will be happy to rectify any omissions of acknowledgements in future if notified.

Copyright © 2008 AQA and its licensors. All rights reserved.