

General Certificate of Education
January 2004
Advanced Level Examination



GENERAL STUDIES (SPECIFICATION A)
Unit 5 Science, Mathematics and Technology

GSA5

Friday 23 January 2004 Afternoon Session

In addition to this paper you will require:

- an objective test answer sheet;
- an 8-page answer book;
- a black ball-point pen.

Time allowed: 1 hour 30 minutes

Instructions

- Use a black ball-point pen for recording your answers to Questions 1.1 to 1.25 on your objective test answer sheet.
- Use a blue or black ball-point pen for answering one question from Questions 2.1 to 2.6.
- Write the information required on the front of your answer book for Question 2. The *Examining Body* for this paper is AQA. The *paper reference* is GSA5.
- Answer **all of** Question 1 (1.1 to 1.25) using the answer sheet provided **and one** question from Question 2.1 to 2.6 in a separate answer book.
- For each item in Question 1 there are several alternative responses. When you have selected the response which you think is the best answer to a question, mark this response on your answer sheet.
- Do all rough work in your answer book, **not** on your answer sheet.

Information

- This paper consists of **two** questions.
Question 1 contains 25 objective test questions based on a variety of exercises in spatial and mechanical relations. Each question carries 1 mark. No deductions will be made for wrong answers.
- **Question 2** consists of six alternative essay questions (2.1 to 2.6).
25 marks are allocated to each of Questions 2.1 to 2.6.

Advice

- Attempt Questions 1.1 to 1.25 before you do **one** from Questions 2.1 to 2.6.
- Spend approximately equal amounts of time on Questions 1 and 2 as a whole.
- Do not spend too long on any item in Question 1. If you have time at the end, go back and answer any question you missed out.
- Make sure that you hand in **both** your answer sheet **and** your essay answer book at the end of the examination.

QUESTION 1

Answer Questions 1.1 to 1.25

For each of Questions 1.1 to 1.25 choose the answer you consider the best of the alternatives offered in A, B, C and D.

Questions 1.1 to 1.8

Water Heater

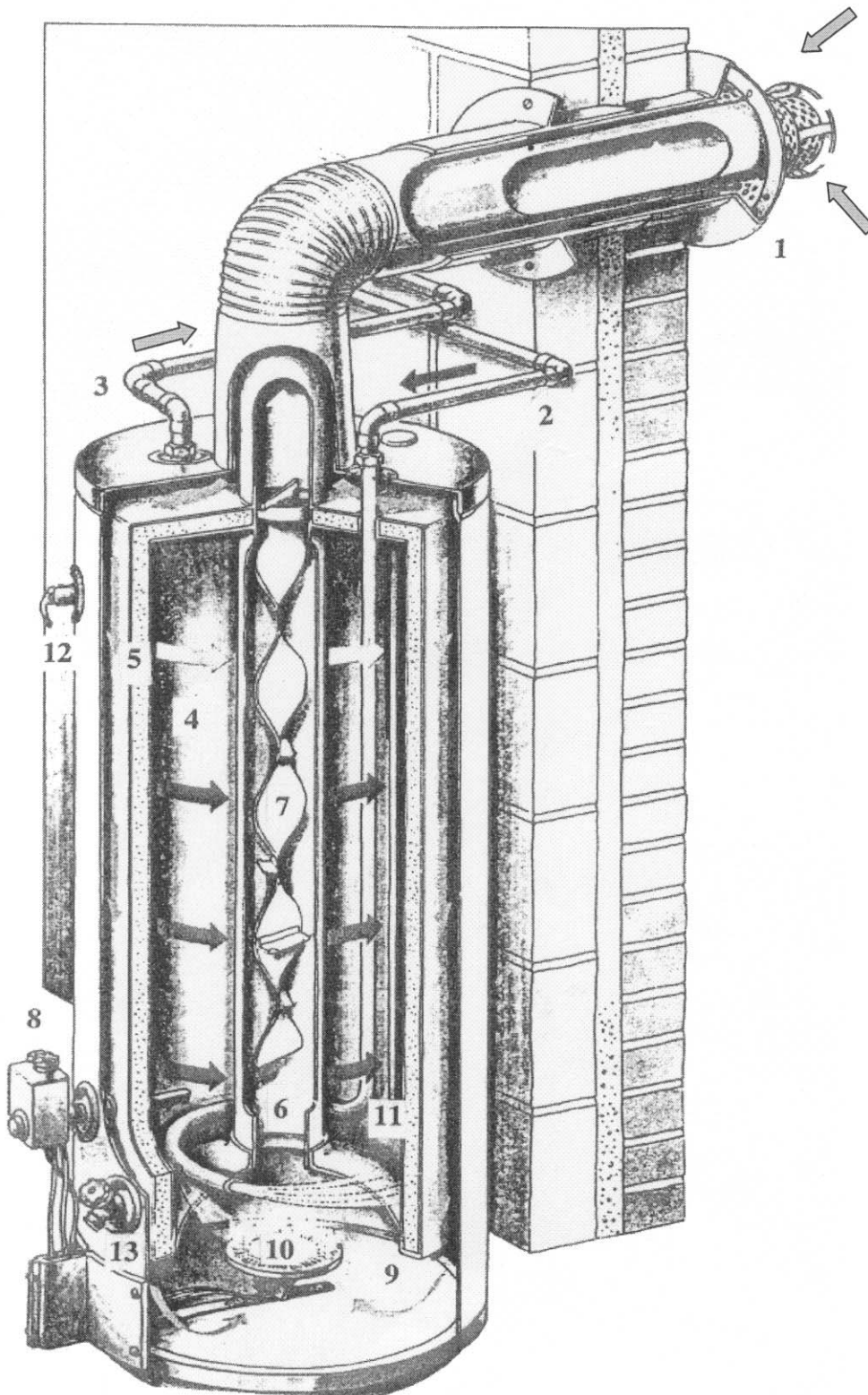

Direct-fired gas water heaters

High-output gas heaters provide instant hot water for the entire house.

Water drawn off by turning on a tap or shower is replaced with cold water introduced to the base of the tank. A thermostat senses the drop in temperature and ignites the gas burner in a chamber below the water tank. Heated gases rise through a flue that passes vertically through the centre of the tank and fresh air is drawn into the burners. As the hot exhaust gases pass slowly up the flue some heat is transferred.

KEY

- 1 Vent (fumes extracted, fresh air introduced)
- 2 Cold-water inlet
- 3 Hot-water outlet
- 4 Water tank
- 5 Insulated jacket
- 6 Flue (carries heated gases to the vent)
- 7 Baffle
- 8 Thermostat
- 9 Burning chamber
- 10 Gas Burner
- 11 Anode rod (protects interior from corrosion)
- 12 Temperature/pressure-relief valve
- 13 Drain valve

1.1 The purpose of the heater is to

- A transfer energy from the gas fuel (10) to the water in the tank (4).
- B heat the fresh air introduced (1) and remove it via the flue (6).
- C heat the room where it is located (e.g. kitchen).
- D condition the air entering the building.

1.2 The fresh air is introduced (1) to

- A cool down the hot air in the flue (6).
- B enable efficient combustion of the gas fuel.
- C keep the thermostat (8) cool.
- D become hot air in the flue (6).

1.3 The fresh air enters the edge of the vent (1) because

- A it is attracted to the gas burner (10).
- B the exhaust gases (1) displace fresh air locally.
- C it is attracted by the hot flue (6).
- D of reduced pressure in the flue (6).

1.4 The base of the water tank (4) is hemispherical because this

- A stimulates the heated water to rise.
- B efficiently transfers heat from the burner.
- C is a standard shaped plumber's item.
- D stacks easily in storage.

1.5 The water in the tank (4) is heated by

- 1 conduction from the gas burner.
- 2 conduction from the hot flue gases.
- 3 the insulated jacket (5).
- 4 the thermostat (8).

Answer

- A if 1 and 2 only are correct.
- B if 1 and 3 only are correct.
- C if 2 and 3 only are correct.
- D if 2 and 4 only are correct.

1.6 The purpose of the baffle in the flue (7) is to

- A** prevent sound emerging at the vent (1).
- B** reflect heat back into the burning chamber (9).
- C** measure the speed of the exhaust gases.
- D** slow down the exhaust gases.

1.7 The main purpose of the thermostat (8) will be to

- 1** turn on the main gas jet and ignition.
- 2** turn off the main gas jet.
- 3** open the drain valve (13).

Answer

- A** if **1** and **2** only are correct.
- B** if **2** and **3** only are correct.
- C** if **1** and **3** only are correct.
- D** if all of them are correct.

1.8 The interaction between the hot gas in the flue (6) and the water in the tank (4) is known as

- A** evaporation.
- B** condensation.
- C** heat exchange.
- D** latency.

Questions 1.9 to 1.13

The shapes of molecules (stereochemistry)

When atoms are joined together by bonds they form a molecule. A few molecules are flat and can be represented satisfactorily on paper, with lines that show rigid and directional bonds between atoms. For example, in boron trichloride, BCl_3 , the single boron atom is always placed in the centre and the three chlorines will be as far apart as possible from each other due to repulsion between electron clouds. The resulting shape is called planar trigonal (flat three angled).

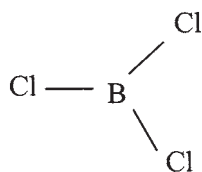

Figure 1

Most molecules will not be flat and cannot be easily shown on paper. A three dimensional model is needed. A simple example is methane, CH_4 . The carbon is central and the hydrogens are placed at the corners of a tetrahedron. This can be drawn in the following ways:

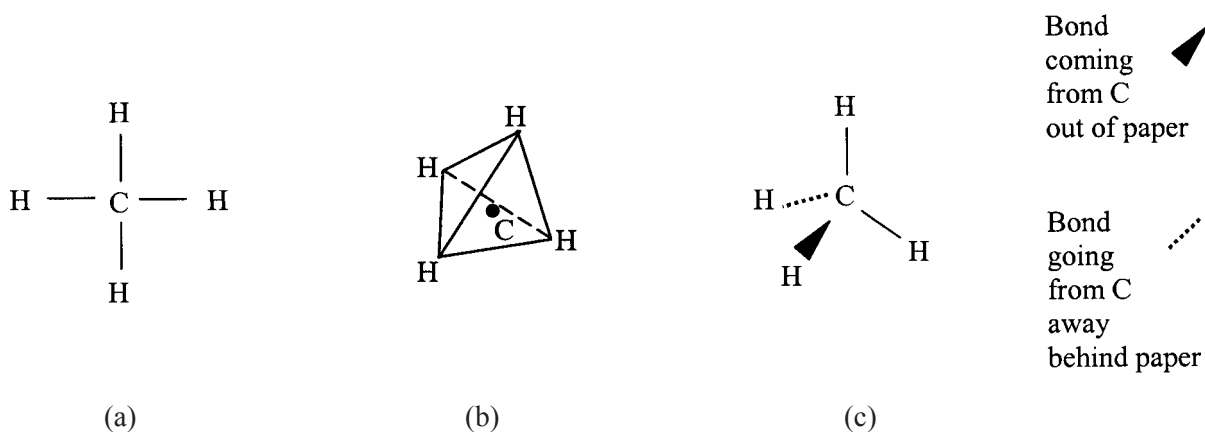

Figure 2

Other typical shapes that occur in molecules are shown below.

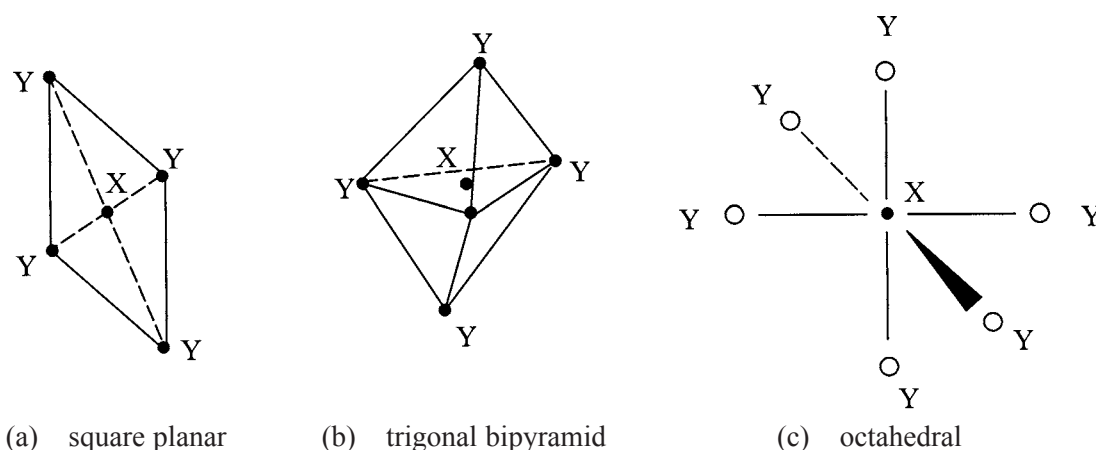

Figure 3

1.9 In an isolated molecule of boron trichloride, BCl_3 (Figure 1) which is flat the angle between the bonds would probably be

- A 60°
- B 120°
- C 180°
- D 270°

1.10 Which of the following illustrates a trigonal bipyramidal molecule (Figure 3)?

A

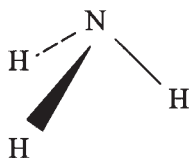

B

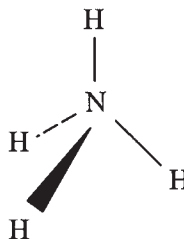

C

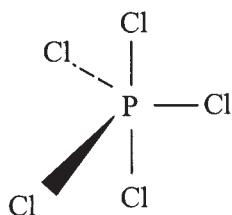

D

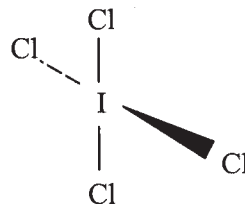

1.11 Which of the following shapes is octahedral (Figure 3)?

A

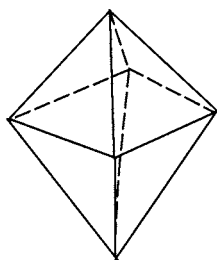

B

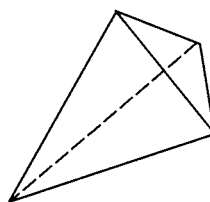

C

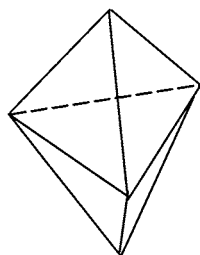

D

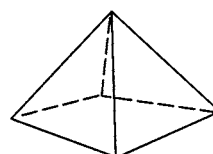

Turn over ►

1.12 Which out of the following shapes could a molecule XY_4 adopt?

- 1** tetrahedral
- 2** planar trigonal
- 3** trigonal bipyramidal
- 4** square planar

Answer

- A** if **1** and **2** only are correct.
- B** if **1** and **3** only are correct.
- C** if **1** and **4** only are correct.
- D** if **3** and **4** only are correct.

1.13 Which of the following shapes could XY_5 adopt?

- A** tetrahedral.
- B** planar trigonal.
- C** trigonal bipyramidal.
- D** octahedral.

Questions 1.14 to 1.16

Molecules having exactly the same atoms but arranged in different ways have different properties and are called isomers. If the atoms are arranged in a different order the isomers are called *structural* isomers - for example C_2H_6O can be arranged as Figure 4(a) ethanol or Figure 4(b) methoxymethane.

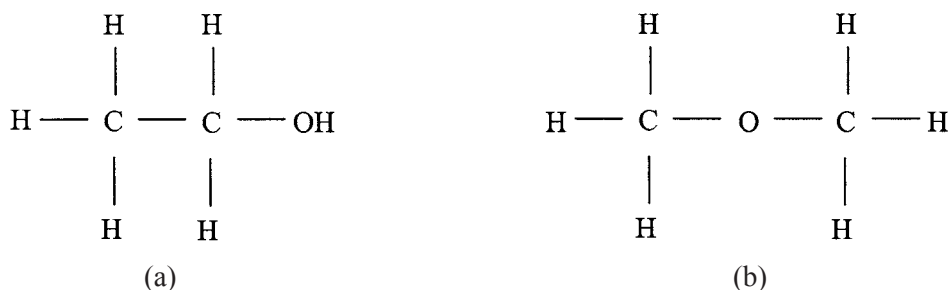

Figure 4

There can sometimes be several different molecules, with different properties, called *geometric* isomers.

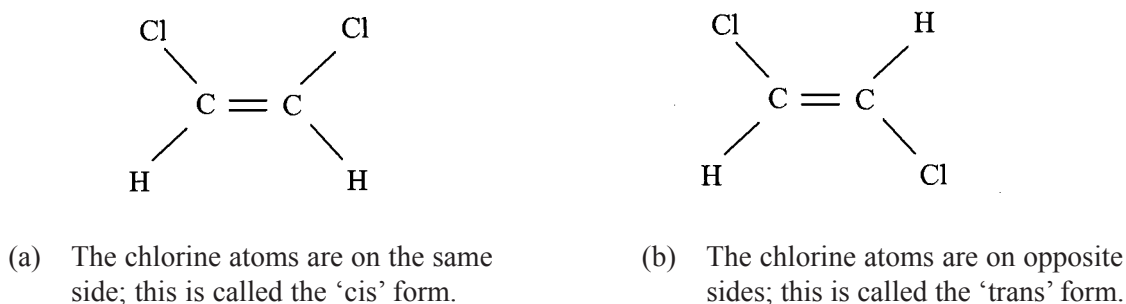

Figure 5

A third type of isomerism can occur if there is no plane or point of symmetry in the molecule. A common example occurs when four different groups of atoms are jointed tetrahedrally to a central atom. These molecules have a right-handed and left-handed version, which are mirror images but can never be superimposed on one another. They are completely different.

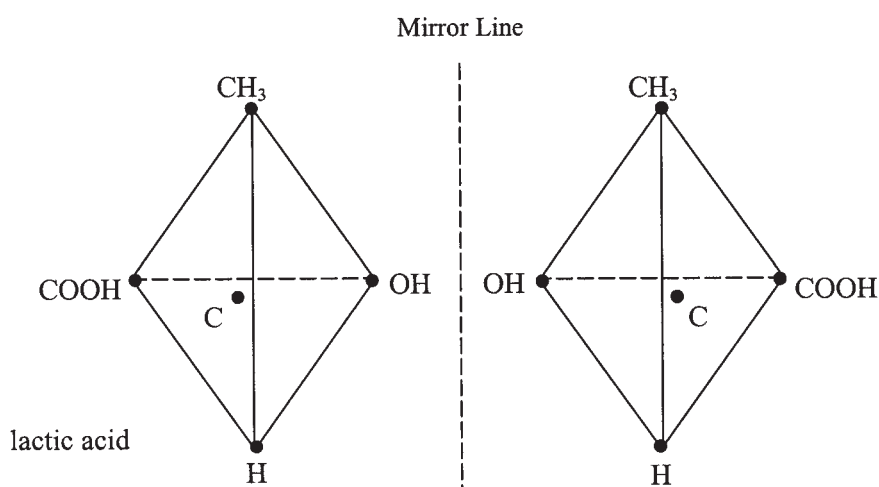
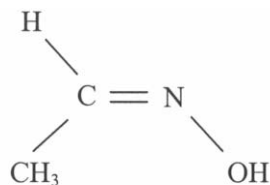

Figure 6

1.14 In Figure 4(a), C_2H_6O may have its formula written as CH_3CH_2OH . The formula in Figure 4(b) could best be written as

- A** CH_3COH_2
- B** CH_3OCH_3
- C** CH_2HOCH_3
- D** H_3COCH_3

1.15 Which one of the following is a geometric isomer to



A

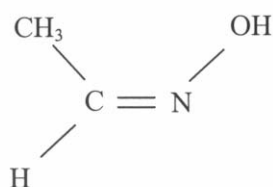

B

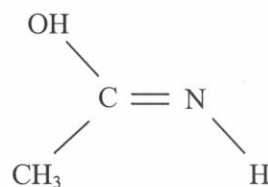

C

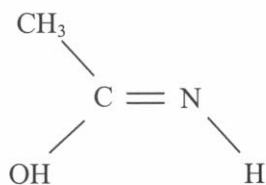

D

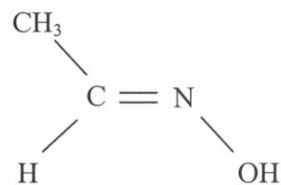

Question 1.16

When a chain of carbon atoms is drawn as

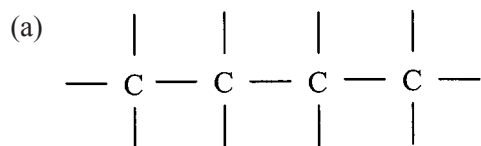

it must be remembered that the bonding is basically tetrahedral and the molecule could look something like

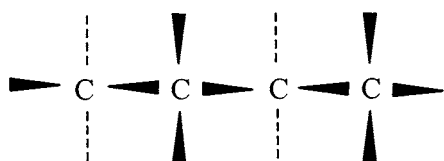

(b) when viewed along the plane of the carbons

and

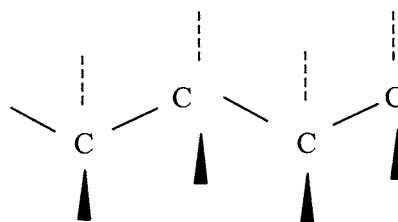

(c) when viewed at right-angles to this plane

Figure 7: Chain of carbon atoms

Rotation of one of the Carbon–Carbon bonds brings groups out of the original plane. Which of the following **cannot** be obtained by a rotation about a bond in the chain?

A

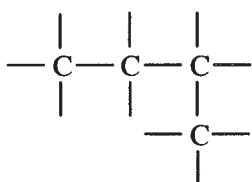

B

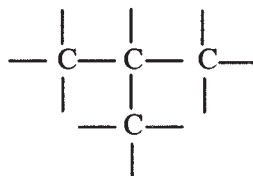

C

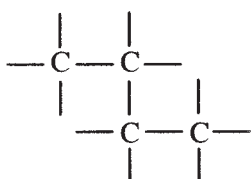

D

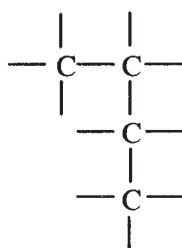

Turn over ►

Questions 1.17 to 1.25*Cams*

A cam is a mechanical device that can be used to change rotary motion into to-and-fro motion in a straight line. An example is the motion of the valves in a car engine. Some children's toys also use cams. Here is an example of a pecking hen:

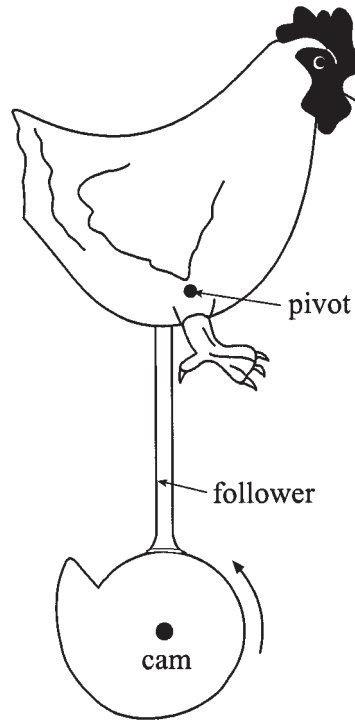

As the cam is rotated anticlockwise, the follower is pushed up and the hen pivots forwards and then falls back suddenly appearing to peck once each revolution of the cam.

Questions 1.17 to 1.19

Figure 8, Elliptical Cam, is for use in **Questions 1.17 to 1.19**

The diagram shows a simple elliptical cam 5 cm long and 2 cm wide. The cam rotates at a steady angular speed about its centre to raise and lower the follower, which remains in contact with the cam throughout the motion. In the **Figure 8(a)**, the follower is shown in its highest position and in its lowest position in **Figure 8(b)**. The difference between the highest and lowest positions is called the stroke.

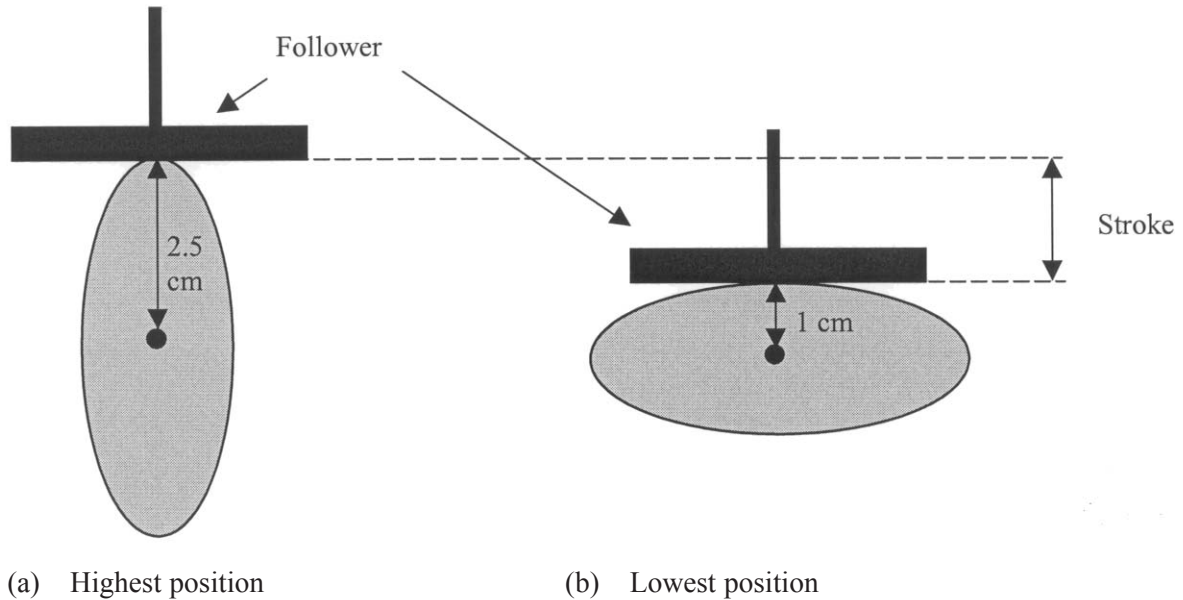

Figure 8: Elliptical Cam

1.17 The follower height (Figure 8a) will next be at its maximum when the cam has turned through

- A** 90°
- B** 180°
- C** 270°
- D** 360°

1.18 The difference in height between the highest and lowest positions of the follower (Figure 8) is

- A** 1.5 cm.
- B** 2.5 cm.
- C** 3 cm.
- D** 5 cm.

Turn over ►

1.19 Which of these elliptical cams will give a stroke of 1 cm?

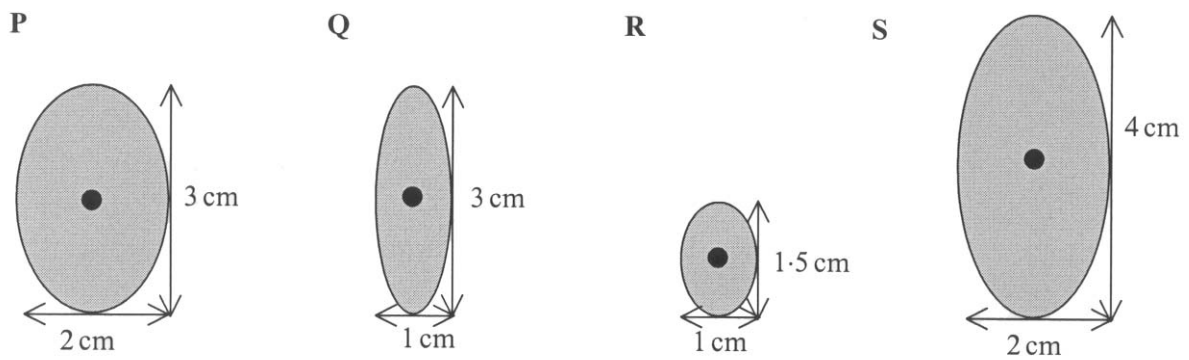

- A P and R only
- B R and S only
- C Q and S only
- D P, Q and S only

1.20 The shape of the cam in the diagram below is made up of a semi-circle of radius 1 cm, which forms the lower part of the cam, and a shape defined by the ends of radii increasing steadily in length from 1 cm up to 2 cm and decreasing back to 1 cm again.

The total vertical distance travelled by the follower in one complete revolution of the cam is

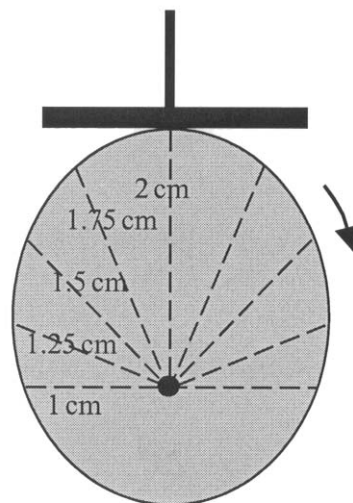

- A 2 cm.
- B 3 cm.
- C 4 cm.
- D 8 cm.

Questions 1.21 to 1.24

The cam shown in this diagram has a profile consisting of three-quarters of a circle of radius 2 cm and a section defined by radii at intervals of 22.5° and with the lengths shown. The cam rotates at a constant angular speed of 3 revolutions per minute, starting from the position shown.

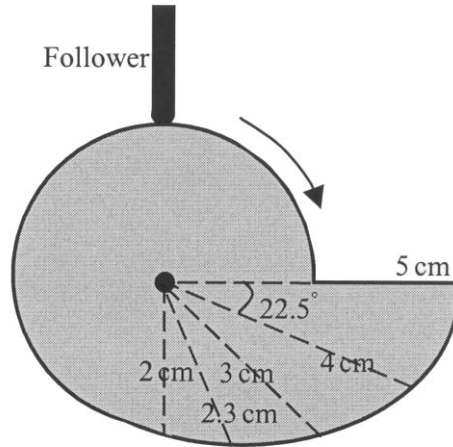

Figure 9

1.21 The follower starts to move

- A** immediately.
- B** after 5 seconds.
- C** after 10 seconds.
- D** after 15 seconds.

1.22 The follower first reaches its maximum height after

- A** 5 seconds.
- B** 15 seconds.
- C** 20 seconds.
- D** 75 seconds.

TURN OVER FOR THE NEXT QUESTION

Turn over ►

1.23 The best sketch graph of the follower height against time for three complete revolutions of the cam starting from the position in **Figure 9** is

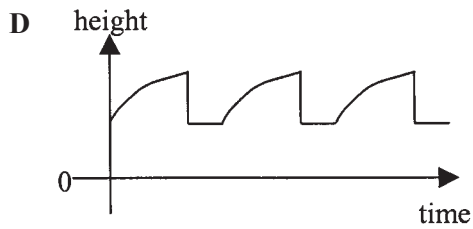
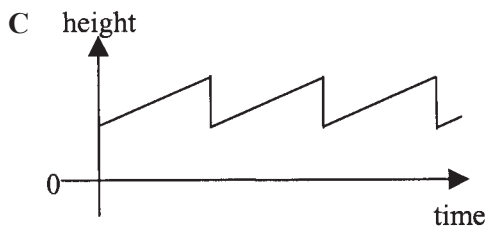
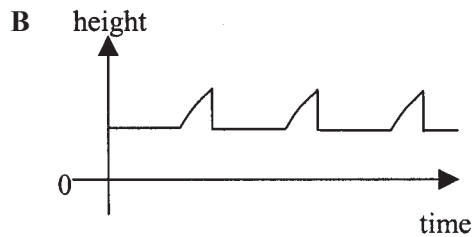
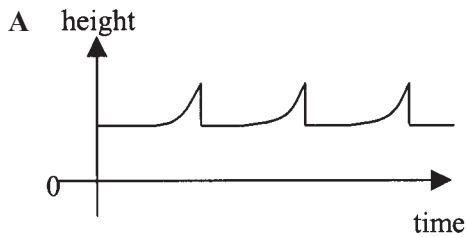

1.24 The height of the follower is increasing most rapidly for the first time after approximately

- A 5 seconds.
- B 15 seconds.
- C 20 seconds.
- D 75 seconds.

1.25 The diagram below shows an eccentric circular cam with radius 4 cm. It rotates about the point A, halfway between the centre of the circle and the circumference. The cam rotates at a constant speed of one revolution per minute.

What is the follower height **above point A** after 15 seconds?

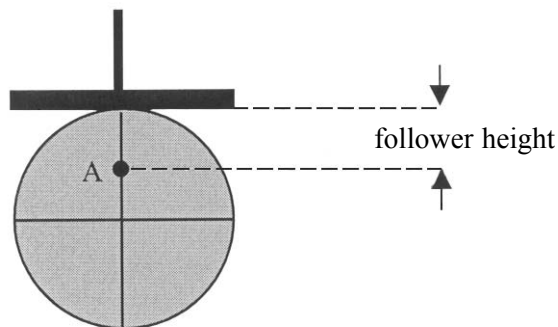

- A 2 cm
- B 4 cm
- C 6 cm
- D 8 cm

END OF QUESTION 1

QUESTION 2

Answer **ONE** of Questions 2.1 to 2.6.

Each question carries 25 marks.

This question must be answered in a separate answer book which must be clearly labelled GSA5 Question 2. Include relevant science wherever appropriate. Write as if you are addressing the intelligent general reader.

The assessment of your answer will take account not only of content but also your use of English, including spelling, punctuation, vocabulary, sentence construction and the organisation of your essay.

- 2.1** Explain why flooding in some parts of the United Kingdom is a regular occurrence and discuss the steps that might be taken to minimise its effects.
- 2.2** Discuss the technological options for electricity production in the United Kingdom and explain why some are preferred to others.
- 2.3** To what extent is it possible to justify the research and expense involved in the voyages of spacecraft, such as Beagle 2, to Mars?
- 2.4** There are several accepted dating techniques e.g. dendrochronology, carbon dating, thermoluminescence. Explain the scientific principles underlying **at least one** dating technique and discuss why we need to use a range of different methods.
- 2.5** “Human cloning is ethically unacceptable”.
- Discuss the extent to which you agree or disagree with this statement.
- 2.6** Discuss the ways of dealing with household rubbish and explain the need to improve recycling methods.

END OF QUESTIONS