

# Internal assessment procedures

---

## Supervision of students and authentication of work submitted

Students must submit a portfolio of work for each of the internally assessed units. Teachers are expected to guide and advise students in the production of their portfolios. Teachers should monitor progress, to ensure that the work is appropriate for the requirements of the specification.

The GCSE, GCE, VCE and GNVQ Code of Practice requires assessors to record full details of the nature of any assistance given to individual students beyond that of the teaching group as a whole, but within the parameters laid down in this specification.

All learners are entitled to initial guidance in planning their work, but the level of assistance required should be taken into account when their work is assessed. When marking the work, assessors should apply the following guidelines.

- *'Some support and guidance'*: The learner has to be guided and advised throughout to ensure that progress is made. The learner relies on the support of the teacher, who has to assist in most aspects of the work. This level of support restricts the learner's mark to band 1, irrespective of the quality of the outcomes.
- *'Limited guidance'*: The teacher supports the learner initially in the choice of topic for investigation. Thereafter, the teacher reacts to questions from the learner and suggests a range of ideas that the learner acts upon. The learner frequently checks matters of detail. The teacher needs to assist in some aspects of the work. This level of support restricts the learner's mark to bands 1 or 2, irrespective of the quality of the outcomes.
- *'Independently'*: The teacher supports the learner initially in the choice of topic for the investigation or task. Thereafter, the teacher occasionally assists the learner, and only when asked, but monitors progress throughout. This level of support gives access to all three mark bands.

In addition, sufficient work must take place under direct supervision to allow the teacher marking the work to authenticate each student's work with confidence.

If students' processing skills are being assessed, it is important that witness statement(s) are completed by assessors, to authenticate student work and to provide evidence that students have achieved the level of performance required in the assessment criteria grid.

## Assessment

The work of each student must be assessed using the assessment criteria grids, which contain criteria statements and bands of response. The assessment must be recorded by centres on the mark record sheets that are used to convert achievement levels to marks. Copies of these forms are in *Appendices C-G* at the back of this document and should be photocopied and attached to each student's portfolio.

## Annotation

Annotation is a mandatory requirement for internally assessed work and is used to:

- help the moderator to understand how and where marks for each assessment criteria have been awarded
- describe where students have received help beyond normal learning support or where students have been rewarded for initiatives that are not immediately apparent from the evidence presented
- explain any other features of a student's work that will assist the moderator in understanding how a particular assessment was arrived at.

The minimum requirement for annotation is to complete the annotation column on the mark record sheet by listing the portfolio page numbers where evidence can be found for each of the assessment criteria.

Further comments can be carried out on the back of the mark record sheet. Detailed annotation will help a moderator to agree a centre's marks. Annotation should not be written directly onto student work.

## Standardisation within the centre

It is the centre's responsibility to ensure that where more than one teacher has marked the work, internal standardisation has been carried out. This procedure ensures that the work of all students at the centre is marked to the same standard and that an accurate rank order is established.

## Internally assessed portfolios

Following assessment, all portfolios must be available for inspection by Edexcel. Each student's portfolio should contain only the work used for awarding marks in the assessment.

Portfolios must have a title page with the relevant specification name and number, candidate name, candidate number, centre name, centre number, and date. The first page of the portfolio should be a contents list and pages should be numbered throughout the portfolio.

A sample of the work will be requested and must be sent to Edexcel to arrive no later than May 15th in the year of the examination. No practical work is to be submitted to Edexcel unless specifically requested.

The moderated coursework will be returned to centres in the autumn term in the year of the examination. Edexcel reserves the right to retain examples of folders for archive, grading or training purposes.

## Support and training

There is a full range of support materials designed for each GCE in this suite. The range includes:

- specimen tests and associated mark schemes
- mark scheme with examiner's report (available each year from 2006 – after the first examination)
- the Edexcel website [www.edexcel.org.uk](http://www.edexcel.org.uk).

Information concerning support material can be obtained from:

Edexcel Publications  
Adamsway  
Mansfield  
Notts NG18 4FN

Telephone: 01623 467467  
Fax: 01623 450481  
Email: [publications@linneydirect.com](mailto:publications@linneydirect.com)

Edexcel delivers a full professional development and training programme to support these GCEs. This includes generic and subject-specific conferences, seminars, workshops and customised events for individual centres.

Further information on professional development and training programmes can be obtained from Customer Services on 0870 240 9800 (calls can be recorded for training purposes).

Email for enquiries: [trainingenquiries@edexcel.org.uk](mailto:trainingenquiries@edexcel.org.uk)  
Email for bookings: [bookingenquiries@edexcel.org.uk](mailto:bookingenquiries@edexcel.org.uk)



# Additional resources

---

## Websites

4 Engineers	<a href="http://www.4engineers.co.uk">www.4engineers.co.uk</a>
Aeronautical Engineering Jobs	<a href="http://www.aeronauticalengineeringjobs.co.uk">www.aeronauticalengineeringjobs.co.uk</a>
Architectural Engineering Jobs	<a href="http://www.architecturalengineeringjobs.co.uk">www.architecturalengineeringjobs.co.uk</a>
Career and Education Centre	<a href="http://www.ce.com">www.ce.com</a>
British Standards Institute	<a href="http://www.bsi-global.com">www.bsi-global.com</a>
British Standards Institute Education	<a href="http://www.bsieducation.org">www.bsieducation.org</a>
European Conformity Marking	<a href="http://www.ce-marking.org">www.ce-marking.org</a>
Electrical Engineering Jobs	<a href="http://www.electricalengineeringjobs.co.uk">www.electricalengineeringjobs.co.uk</a>
Health and Safety	<a href="http://www.healthandsafety.co.uk">www.healthandsafety.co.uk</a>
Health and Safety Executive	<a href="http://www.hse.gov.uk">www.hse.gov.uk</a>
Institute of Electrical Engineers	<a href="http://www.iee.org.uk">www.iee.org.uk</a>
Institute of Incorporated Engineers	<a href="http://www.iie.org.uk">www.iie.org.uk</a>
Job Engineer	<a href="http://www.jobengineer.co.uk">www.jobengineer.co.uk</a>
Mechanical Engineering Jobs	<a href="http://www.mechanicalengineeringjobs.co.uk">www.mechanicalengineeringjobs.co.uk</a>
National Engineering Federation	<a href="http://www.nef.org.uk">www.nef.org.uk</a>
Naval Engineering Jobs	<a href="http://www.navalengineeringjobs.co.uk">www.navalengineeringjobs.co.uk</a>
Royal Society for the Prevention of Accidents	<a href="http://www.rospa.org.uk">www.rospa.org.uk</a>
Roymech	<a href="http://www.roymech.co.uk">www.roymech.co.uk</a>
SEMTA	<a href="http://www.semta.org.uk">www.semta.org.uk</a>
Trade Union Congress Health and Safety	<a href="http://www.tuc.org.uk/h_and_s">www.tuc.org.uk/h_and_s</a>
UK Civil Engineering	<a href="http://www.ukcivilengineering.co.uk">www.ukcivilengineering.co.uk</a>
UK Engineer	<a href="http://www.ukengineer.co.uk">www.ukengineer.co.uk</a>

## Books

Please see individual units within the Edexcel GCE in Engineering specification.



# GCE Portfolio Marking Guidance

---

The GCE Portfolio Marking Guidance is designed to give guidance on how to apply the assessment criteria grids, and to enable teachers an impression of the kind of work that may be produced as the specification is applied. Each example of work is of a style and a standard as near as possible to the requirements of the new GCE.

This document is designed for general guidance. Full details of the course requirements can be found in the specification, guidance on internal assessment and the assessment criteria. The specification should be referred to for more definitive information.





# Applying the mark bands

---

Portfolios will be marked by the centre, and externally moderated by Edexcel. Each of the internally assessed units has a marking grid, divided into three broad mark bands, showing how to award marks in relation to the task and the assessment objectives. The marking grids indicate the required assessment outcomes as well as the quality of the outcomes needed for achievement in each of the mark bands. Mark band 1 relates to the expectations given in the grade description for grade E; mark band 2 relates to the expectations for grade C, and mark band 3 relates to the expectations for grade A. For further information on grading, see the section *Grading and aggregation* which follows this section.

In general terms, progression across the bands is characterised by:

- increasing breadth and depth of understanding
- increasing coherence, evaluation and analysis
- increasing independence and originality.

The unit assessment criteria grid shows the allocation of marks by assessment criterion and by mark band. This grid should be used to determine marks for student achievement in each unit. Students can achieve marks in different bands for each assessment objective. The total mark achieved will depend on the extent to which the student has met the assessment criteria overall.

Within each assessment criterion, it is a general principle that shortcomings in some aspects of the assessment requirements may be balanced by better performance in others. However, it is also important to note that for full marks in any particular assessment criterion, all the requirements should have been met.

Marks should not be awarded on the basis of a 'tick list' of factual content but on the overall response as it relates to the requirements stated within each mark band. Assessors should adopt a holistic approach and apply their professional judgement.

There should be no reluctance to use the full mark range and, if warranted, assessors should award maximum marks. Students' responses should be considered positively. A mark of 0 should only be awarded where the student's work does not meet any of the required criteria.

The grade descriptions for the Edexcel GCE in Engineering refer to the levels of support and guidance required by students in carrying out investigations and tasks. All students are entitled to initial guidance in planning their work. When marking the work, assessors should apply the following guidelines:

- **'Some support and guidance'**: the student has to be guided and advised throughout to ensure that progress is made. The student relies on the support of the teacher, who has to assist in most aspects of the work. This level of support restricts the student's mark to band 1, irrespective of the quality of the outcomes.
- **'Limited assistance'**: the teacher supports the student initially in the choice of topic for investigation. Thereafter the teacher reacts to questions from the student and suggests a range of ideas that the student acts upon. The student frequently checks matters of detail. The teacher needs to assist in some aspects of the work. This level of support restricts the student's mark to bands 1 or 2, irrespective of the quality of the outcomes.
- **'Independently'**: the teacher supports the student initially in the choice of topic for the investigation or task. Thereafter the teacher occasionally assists the student, and only when asked, but monitors progress throughout. This level of support gives access to all three mark bands.

For internal record-keeping purposes, centres may wish to make a copy of the assessment criteria grid for each student and use it to record the mark for that unit. The GCSE, GCE, GNVQ Code of Practice requires assessors to show clearly how credit has been assigned.

## Grading and aggregation

The overall grade for:

- Advanced Subsidiary qualifications will be graded on a five-grade scale from A to E where A is the highest grade
- Advanced GCE qualifications will be graded on a five-grade scale from A to E where A is the highest grade.

The mark bands used for internal assessment do not relate to pre-determined grade boundaries. Following each examination and moderation series, Edexcel will set the grade boundaries for both internally assessed units and the externally assessed units at an awarding meeting.

The raw mark boundaries will be converted to uniform marks on a scale of 0-100. The final grade for the qualification will be determined by aggregating the uniform marks for the units. The following table gives details of the uniform mark scales (UMS) used for the units and for the qualifications.

### Unit results

The minimum uniform marks required for each grade:

Unit grade	A	B	C	D	E
Maximum uniform mark = 100	80	70	60	50	40

Candidates who do not achieve the standard required for a grade E will receive a uniform mark in the range 0-39.

### Qualification results

The minimum uniform marks required for each grade:

#### Advanced Subsidiary

Qualification grade	A	B	C	D	E
Maximum uniform mark = 300	240	210	180	150	120

Candidates who do not achieve the standard required for a grade E will receive a uniform mark in the range 0-119.

#### Advanced GCE

Qualification grade	A	B	C	D	E
Maximum uniform mark = 600	480	420	360	300	240

Candidates who do not achieve the standard required for a grade E will receive a uniform mark in the range 0-239.

Performance descriptors are given in the GCE in Engineering specification in *Appendix D*.

## Exemplars and commentary

---

The section contains exemplar student work for *AS Unit 2: The Role of the Engineer*, *A2 Unit 4: Applied Engineering Systems* and *A2 Unit 6: Applied Design, Planning and Prototyping*. Each example of work is of a style and a standard as near as possible to the requirements of the new GCE.

In each unit, exemplar student work is shown followed by a commentary on the overall performance for that particular criterion.



## Unit 2: The Role of the Engineer

### The assignment/brief

A leading UK manufacturer in single-use laboratory plastics has set standards for quality and reliability in the increasingly sophisticated field of life science. The company has established a range of plastic disposable products required by pharmaceutical, food, dairy and water testing laboratories. Continuous investment in the latest technology means that the company can make products to the highest possible standards.

Rotation of samples at specific speeds (centrifugation) has been used in many fields as a separation method. This action usually takes place in tubes, which can, if adequately supported, tolerate centrifugation at such speeds in excess of 5000g.

You are required to investigate the role of an engineer within the company and the part they have to play in the design or manufacture of a disposable centrifuge tube.

In order to achieve the assessment criteria for this assignment you will need to:

- investigate the different activities the engineer is responsible for during the design or manufacture of the product
- provide details of the modern technologies available to the engineer, why they were used and what impact has their use been on the environment
- provide evidence of documents from the engineering workplace with confidential material being made anonymous
- examine health and safety standards used by the engineer when designing or manufacturing the product
- evaluate the engineered product by looking at its fitness for purpose and intended performance, giving objective answers supported by reliable evidence
- suggest possible modifications against the above evaluation criteria to improve the performance of the engineered product.

## Exemplar student response for assessment criteria (a)

*The activities undertaken by the engineer in the design and/or manufacture of the engineered product or service.*

During my visits to this company I met and interviewed the Senior Development Engineer (SDE) relating mainly to the design of the engineered product — centrifuge tube.

As a Senior Development Engineer this person has a wide variety of roles to play in the design of this product. I have categorised them under the following headings:

### **Product development**

An initial assessment of the requirements for the centrifuge tube is undertaken. A meeting was arranged with the marketing department. This department investigated the different types of centrifuge tube on the market and collected relevant samples for the SDE to assess. Marketing has a much better understanding of their competitors and associated products. The SDE also met with the customer and the following specification points were required of the product:

- the product must fit a standard centrifuge machine
- it must withstand a centrifugal force of 6000g
- it must be resistant to attack from numerous chemicals and substances used in a wide range of laboratories
- the product must be able to be supplied sterile if required
- a secure sealing cap must be fitted that can be easily removed
- the product must be capable of mass production.

Assessment of any specific standards that may be applicable to the design of the centrifuge tube.

Assessment of regulatory requirements and responsibility.

### **Research and development**

Research into suitable materials for the centrifuge tube. Similar existing products and/or materials are evaluated for physical, chemical and regulatory performance and conformity. In this case the product will be used for wide range of applications. Using some technical data from the company, the most appropriate material to use would be polypropylene. This material has a good to excellent resistance to a broad range of common laboratory chemicals.

Research into specific performance criteria and/or customer requirements is undertaken. In this case the standards and testing to meet and withstand a force of 6,000g.

### **Design — aesthetics, CAD and production realisation**

Design of product would be the sole responsibility of the Senior Development Engineer. He would use his knowledge and experience of medical devices to produce some designs for the customer to view. The customer knows what product he wants but his lack of engineering experience requires the broad knowledge of the SDE. The SDE would first look at the processing method to be used, in this case Injection Moulding. In order to meet the customer requirements of mass production he proposed a four-impulsion container and cap mould, both with a hot runner system. Appropriate cycle times of 15 seconds for both container and cap were proposed to meet production costs. The SDE then develops a tool design to be approved by the customer. Once approved, the drawing would be sent to the toolmaker that would then supply a General Assembly (GA) for approval by the SDE.

The customer would not be consulted at this stage as the SDE underwrites the quality and reliability of the tooling.

The Senior Development Engineer would liaise with the draftsman in the drawing office to produce sub-assembly and assembly drawings. Here the engineer would formalise his ideas, producing drawings to current standards. Each part of the centrifuge tube would be drawn accurately to provide toolmakers with the necessary detail to produce an injection mould tool for production.

Product realisation may be achieved by subcontracting the production of working models or mock-ups; this does include companies that specialise in mould-making, as well as more modern techniques such as 'Stereo Lithography'.

Prototype tooling is also used if testing is required to verify attributes of the product or design, before the final design is established before the commissioning of production tooling.

### **Planning and control**

The Senior Development Engineer controls all product 'Design and Development'. This is carried out for compliance to ISO 9000:2000.

Materials requirements will be established during the development process. The Senior Development Engineer, in conjunction with the purchasing department, will arrange the sourcing of all externally sourced materials or parts that are not already used by the company, in this case virgin grade Polypropylene.

The Senior Development Engineer, in conjunction with the planning department, will arrange raw material codes and part numbers. This information will be required for all aspects of control of production from Sales being placed on to the company production control system, through purchasing, planning, production, dispatch and stock control.

### **Production and manufacturing**

Assistance is offered during the early stages of production of the centrifuge tubes to supply relevant information on quality and production issues or requirements.

### **Quality**

The Senior Development Engineer, in conjunction with the quality department, will raise the MQS (Master Quality Specification).

The Senior Development Engineer, in conjunction with the production department, will raise work instructions and work procedures.

### **Costing and estimating**

Tooling costs and production costs will need to be estimated during the initial stages of the project to evaluate the viability of the product.

The Senior Development Engineer, in conjunction with the accounts department, will calculate accurately production costs prior to the production process beginning.

Marketing will establish the selling price from the production cost.

## Overall performance for assessment criteria (a)

*The activities undertaken by the engineer in the design and/or manufacture of the engineered product or service.*

On one hand Jodie has described a range of examples of the activities carried out, and how they relate to a specific product. Jodie has produced evidence of a range of relevant activities performed by the engineer within this company. She has described some of these activities such as the product development where a clear list of requirements has been drawn up and the design stages describing how an idea is created through to tooling design. Jodie has stated that her work is the result of an interview with the engineer, and her work does appear to have been developed independently, and not to have been led by the teacher. Greater independence would have been indicated if Jodie had realised that she lacked certain information and had asked supplementary questions after the initial interview, perhaps by email.

It is difficult to be specific without actually seeing the information on the specific role that this engineer has – as defined by the employer – but some evidence of responsibilities for staff such as junior design engineers, and some responsibility for costs and budgetary control would be normal in such a position – and these are not mentioned at all in Jodie's evidence. This indicates that the evidence does not cover 'most of the activities' as required for the evidence to fit into the third mark band. There is general information on the activities undertaken by the engineer, but little detailed explanation of the actual activities undertaken by the engineer, or justification of why they are important in the context of this product. The communication provided is logically laid out and reasonably well presented, using appropriate terms and words. It supports the award of marks in band 2.

Therefore Jodie's work meets the requirements of mark band 2.

However, in order to meet the requirements of mark band 3, there are a number of activities that lack depth, such as the quality section, where Jodie needed to provide examples of 'working instructions and procedures' specific to the product. She could have included details in the production and manufacture section giving examples of the types of solutions and interactions involved. There could have been further explanation of the types of interactions between the engineer and the planning department. Jodie could have described how the engineer interrelated to other engineering staff and described any line management responsibilities. Finally under the heading 'costing and estimating', she could have discussed the importance of costs/schedules and how it affects design decisions, and in particular the engineer's responsibilities with regard to costs and budgets. Therefore Jodie's work was insufficiently detailed to meet the requirements of mark band 3.



## Exemplar student response for assessment criteria (b)

*Current available technologies used by the engineer including why they were selected as being appropriate to the process.*

### **Information communication technology**

Existing product investigation means the SDE has the internet at his disposal to trace similar products that meet customer requirements. However this is mainly the responsibility of the marketing department as stated earlier. This provides the SDE with the latest technical information at the touch of a button. Companies are able to trade online and have a product catalogue to view at any time of the day or night. This information can be transferred accurately and efficiently between all departments in the company and even to other premises around the country. Products can be analysed without the need to approach the company direct or without the company knowing that you are a competitor. The company has its own website, which houses a technical database for materials, sterilisation processes and products. Please also note that the SDE uses competitors' databases to analyse existing products.

The engineer would enter the website of his company to find the technical database for Physical Properties and Chemical Resistance of Plastics. He would be able to examine a range of the plastics for their suitability. As the customer requires a range of solutions to be used in the tubes, the SDE would use his experience and select the appropriate material, in this case Polypropylene.

Having opened the database for Polypropylene, the SDE would now analyse this material. The codes used by the company are a result of many years of testing. Therefore the SDE relies very much on the accuracy of these codes. For instance this material is suitable because it has excellent mechanical properties enabling it to withstand large 'g' forces, it has a high temperature resistance allowing hot solutions to be tested. It also enables the tube to be sterilised by irradiation.

### **Email**

The use of electronic mail now provides the engineer with a quick, cheap and efficient method of communication that can be relayed to the customer at any time. From the comfort of his office he can query information specific to the centrifuge tube. Some examples of the types of information sent to the customer or other parts of the company:

- email the customer with drawing for approval
- once approved, email tube drawing to the toolmaker
- check customer requirements for packaging; distribute to relevant suppliers as necessary
- request written approval for modifications to product or specifications.

Email is not the only form of communication used by the SDE. He will often use the postal system to provide the customer with a clearer drawing of the centrifuge tube and the tooling. This particular customer only has an A4 printer and therefore large drawings are almost impossible to read when sent via email. The customer has also received samples of similar products through the postal service, enabling the customer to view and comment on this product and its suitability. The customer then telephones the SDE to approve/disapprove product, but the SDE will always insist on email or letter reply if to build up a technical file to help prove regulatory responsibility. One problem the SDE has encountered with the modern technology of email is that the inbox gets quite full so he has to take hard copies of all correspondence for the Technical File and then delete the messages to allow mail to arrive from other customers.

## **Computer aided design**

The SDE uses AutoCAD 2002 to produce formal drawings. This can be accessed within his office on the desktop computer. Using his knowledge and experience he is able to produce designs that can easily be manipulated and modified. Each part of the centrifuge tube can be drawn to recognised standards and then shown to the customer or any of the other engineers within the company. The computer system has a built-in maths co-processor, which allows the SDE to produce designs very accurately without the use of a calculator. Product simulations can also be achieved using this software allowing the customer to view the product before production.

## **Centrifuge tube design**

The SDE has created the drawings overleaf to industry standards. This means that engineers from other parts of the company involved in the design or manufacture of this product will be able to read and understand the drawing. Using the customer requirements the SDE begins to draw the tube with the AutoCAD software. The SDE would already have a drawing template to the industry standard saved on his computer thus reducing the times for drawing production.

The tube itself would be produced first as the size of this part is determined by the centrifuge machine standards. A diameter of 27.9mm is not to be exceeded, as this will not fit the centrifuge machine. As it is a 50ml tube, with the diameter restricted to 27.9mm then the SDE will need to calculate the length of the tube to accommodate 50ml of fluid. Once the tube length has been established then tube printing will be drawn. A crucial part of the design is the thread at the top of the tube. These have to meet British Standards that will be dealt with later on. The SDE has gone for a single start right hand thread with 1.5 full turns. This makes it easier for the technicians to replace the lid during testing.

## **Using AutoCAD**

The drawings overleaf would take quite some time to produce by hand. The use of AutoCAD will allow the SDE to produce his drawings with speed and accuracy. The following information gives details of some of the activities that make this possible.

### **Snap facility**

When dimensioning the product, accuracy is increased by the use of a Snap facility. This means the SDE can click an area on the drawing close to where he wants his dimension to start and it would 'Snap' to the Endpoint or Intersection where the dimension would be required.

### **Offset and co-ordinate entry**

Just drawing the parts themselves has been made very easy. When the SDE begins to draw a line, the size and angle of that line appear on the bottom of the screen as the mouse is moved. The SDE can also create lines by co-ordinate entry. Technically it is possible to create most parts of the drawing just by typing in co-ordinates. There is also a very useful facility called 'Offset'. Many components can be built by offsetting a particular line to create another part of the drawing.

### **Clipart symbols**

The SDE can also use a library of stored symbols to add to his drawing rather than create them every time. Many components are standard across a variety of engineering disciplines.

### **Using layers**

The SDE has used different colours for different parts of the drawings. Although the drawings are produced on one sheet, the SDE has a facility to draw each part on a different 'layer'. Here the outlines of the parts are drawn in black; the text and dimensions are then produced on another layer. This allows the engineer to view the product without the dimensions being present. Similarly, when different colours are used then a different layer is also used just for this purpose.

## **Linetypes**

The SDE has created the drawings with the industry standard linetypes. A short dashed line represents hidden detail and centre lines are represented by a series of short and long lines. The SDE does not have to draw each line; he just selects the appropriate linetype from a list within the computer software. Once the linetype has been selected, it can easily be accessed to use for another part of the drawing. Again these would be placed on different layers to allow easy viewing of specific linetypes.

The cap for the tube would be drawn last of all. This needs to provide ease of movement and a seal to prevent solutions from leaking. Again this drawing is produced on a single sheet but on different layers to allow the SDE to view parts of the design separately and to evaluate the fits and threads on the cap to the bore of the tube. By using layers parts can be removed easily to view other parts of the drawing and added to create a product assembly drawing. Notice the seal in the roof of the cap, which is crucial to preventing solution leakage. The same thread will be used inside the cap but this time it will be an internal thread. The SDE needs to consider shrinkage allowance of the polypropylene material. This will affect both the tube and the cap. The moulds for these parts as usually made slightly larger, approximate shrinkage allowance are 0.07mm per 25mm in length.

## **Hatching**

If you observe the section through the cap, this type of hatching would take up a great deal of time if drawn by hand. This procedure is made easy by a process called Boundary Hatch. It involves clicking your mouse inside the relevant section of the drawing and it automatically locates the boundary. The software then allows you to select a hatch type and it will fill the area within seconds. All lines will be parallel and the same distance apart.

## **Blocks**

Once the SDE has drawn the Centrifuge Tube once he then has the capability of re-creating that drawing as a 'Block'. This feature allows copies of the Centrifuge Tube to be drawn on a regular basis. An added advantage of blocks is that they can be resized during insertion into a drawing, making them larger, smaller, changing the ratio along the x and y axis or rotating to a different angle. A further bonus is that these blocks can also be used on other drawings, so objects common to a number of drawings need only be drawn once.

## **Creating dimensions**

There are a number of different dimensions used to produce the drawings in my assignment. Before dimensioning the drawing the SDE needs to set up the style and method of dimensioning. This facility allows the SDE to modify the way the dimensions will be drawn on the drawing. He has the capability to alter the angle of dimension lines, the length of extension lines and the size of the arrowheads. More importantly he can set styles to display linear and angular dimensions, diameters and radii. Once the style has been set, it can be stored and used at any time.

The SDE now uses the dimensioning facility to add dimensions directly on to the drawing, without the need to measure any part. As long as the SDE uses the Snap facility described earlier to position the cross hairs, the maths co-processor inside the pc will determine the accuracy of the dimensions. The dimensioning tool also allows the SDE to use leader lines to position important text on the drawing.

1	2	3	4	5	6	7	8	9	10	11	12												
DO NOT SCALE! DRAWINGS MUST NOT BE COPIED OR CHANGED WITHOUT TECHNICAL AUTHORITY IF IN DOUBT - ASKI																							
<table border="1"> <tr> <td>CHECKED</td> <td>REV.</td> <td>DRG. FILE No.</td> <td>MODIFICATIONS [P.S.A. No.]</td> <td>DATE</td> <td>BY</td> </tr> <tr> <td></td> <td>01</td> <td></td> <td>FIRST REVISION</td> <td>17/06/04</td> <td>N.J.</td> </tr> </table>												CHECKED	REV.	DRG. FILE No.	MODIFICATIONS [P.S.A. No.]	DATE	BY		01		FIRST REVISION	17/06/04	N.J.
CHECKED	REV.	DRG. FILE No.	MODIFICATIONS [P.S.A. No.]	DATE	BY																		
	01		FIRST REVISION	17/06/04	N.J.																		

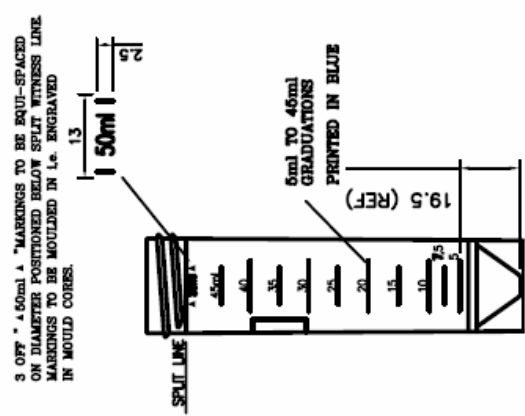
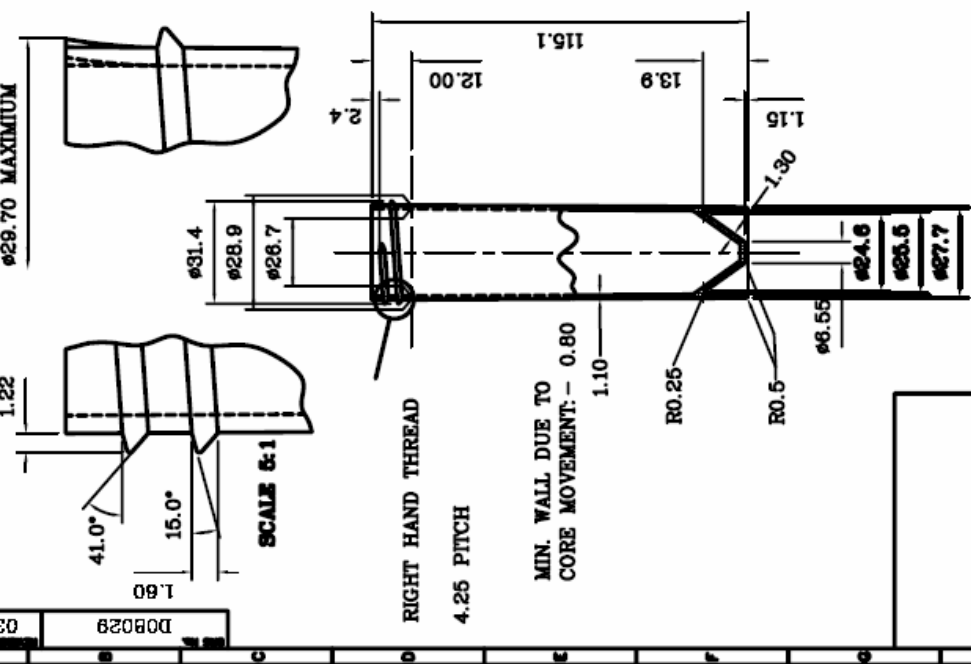

CHARACTER HEIGHT - 2.5 mm

TOLERANCES (U.S.O.)	FORM	DATE
	N.J.	17/06/04
APPROVALS	APPROVALS	APPROVALS
APPROVALS	APPROVALS	APPROVALS
APPROVALS	APPROVALS	APPROVALS
APPROVALS	APPROVALS	APPROVALS
THIRD ANGLE PROJECTION	SCALE	TOOL No.
	A2	T276
	DIMS IN	REVISION
	MM	03
	PRODUCT	01
	50ML SKIRTED CENTRIFUGE TUBE	

ALL PRINTS TO BE STAMPED.

1	2	3	4	5	6	7	8	
DRAWINGS MUST NOT BE COPIED OR CHANGED WITHOUT TECHNICAL AUTHORITY DO NOT SCALE!		IF IN DOUBT - ASK!		CHECKED	REV.	[DRG. FILE No.]	MODIFICATIONS [P.S.A. No.]	
01 01	A	R&D\0399						DATE
A	REVISION	DRG No.						BY
<p><b>THREAD DETAILS</b></p> <p>SINGLE START RIGHT HAND THREAD 4.25 PITCH 1.5 FULL TURNS</p>								
<p><b>MATERIAL: - H.D.P.E.</b> (DSM 7108)</p> <p><b>COLOUR: - BLUE</b> (MP 1759)</p> <p><b>ACTUAL SIZE</b></p>								
<p><b>ALL PRINTS TO BE STAMPED.</b></p>								
TOLERANCES (U.S.G.)		DRAWN N. J.		DATE 15/08/03		<small>This drawing is the property of ABC Ltd. and is subject to return upon request. It is to be used only for the purpose for which it was expressly issued, and is not to be used in any way detrimental to the interests of ABC Ltd.</small> TITLE <b>CAP FOR 50ML CENTRIFUGE TUBE</b>		
THIRD ANGLE PROJN		APPROVALS		APPROVALS		APPROVALS		
A3		DIMNS IN MM		SCALE 4:1		TOOL No.		
PROJECT		DRG No.		R&D\0399		REVISION A		
SHIT. OF		01		OF		01		

### **Injection moulding**

Process controlled injection moulding machines provide close monitoring of all parameters for moulding and also gives the facility for variable control such as varying injection speed or pressure throughout the cycle. Previous machines had to maintain constant speeds and pressures. Parameters can be stored on these modern machines providing accurate settings for different products and materials. Prior to this, setters had to use their knowledge and experience of a particular machine and product to set the parameters and then take time to adjust them to meet the required objectives. Production times would then increase due to the delay of parameter setting. There was also less chance of a mistake being made because all the specific parameters are stored within the machine.

### **Robotic pick off machines**

New technology such as robotic pick off is required with the Centrifuge Tube that removes the product from the mould and transports it to special purpose sealed conveyor systems, because of clean room standards or requirements. Previous operations on the machine meant the product would drop into a bin and then be transported manually to the clean room, thus risking contamination. It is very important that sterile products remain in an enclosed environment, particularly in the light of the recent MSRA bug.

### **Automatic capping**

Automatic capping machinery is used within the company, bespoke machines, made for the company. They have replaced the use of manual labour to cap the centrifuge tubes. Two advantages, sterility and cleanliness or investment in equipment to reduce product cost. There is also an increase in production levels as it is quicker to operate. This process also allows you to specify production speeds. Centrifuge tubes can fall and damage when not picked off by machine, but cycle time increases slightly. There is a need for the SDE to way up costs of production against scrap, remembering that plastic is not re-used as the product only uses 'virgin grade' material as it needs to be sterilised.

### **Material supply**

Material feed system is totally enclosed from the tanker to the injection moulding machine. The material would be supplied at the side entrance of the site, close to the large hoppers. Material would then be fed into the hoppers via the tanker hose, totally sealed. Once in the hopper, there is a feed system that runs directly to all the injection moulding machines without the need to expose the material to contaminated areas of the site.

## Overall performance for assessment criteria (b)

*Current available technologies used by the engineer including why they were selected as being appropriate to the process.*

Jodie has identified specific technologies used to design the engineered product such as the use of Information Communication Technology. She has clearly described and explained the use of email very effectively. The specific statement of the use of email as to track agreements is important. She has also explained clearly the advantages of the use of the internet to obtain technical data, from both other companies websites, and also from the restricted area of the companies own website (or intranet). The use of AutoCAD and the functions used to produce drawings quickly and accurately has also been detailed, with particular reference to the advantages to the engineer. Jodie has also described the use of manufacturing technologies in the manufacture of the engineered product such as Process Control Injection Moulding and Robotic Pick Off machines, and has explained why these are an advantage over other methods of manufacture. Jodie's work also communicates the information to a high standard, and makes use of appropriate technical terms used correctly. It is apparent from looking at the work, that this portfolio is likely to represent the individual work of a particular student.

Please note that it is not a requirement to include drawings, but Jodie has included them as a useful vehicle for bringing out/demonstrating her understanding of the relevant points. However inclusion of such support information can make it easier for the assessor to determine the level of accuracy and completeness of the student's work.

Therefore Jodie's work meets the requirements of mark band 3.

## Exemplar student response for assessment criteria (c)

*How appropriate legislation and standards influenced the design and/or manufacture of the engineered product or service.*

### **Medicines and Healthcare products Regulatory Agency (MHRA)**

The centrifuge tube is subject to regulations determined by the MHRA. This agency is an executive agency of the Department of Health and has replaced the Medical Devices Agency (MDA) and Medicines Control Agency (MCA).

The aims of the MHRA are to safeguard public health by:

- ensuring that medicines for human use, sold or supplied in the UK, are of an acceptable standard of safety, quality and efficacy
- ensuring that medical devices meet appropriate standards of safety, quality and performance
- promoting the safe use of medicines and devices.

The key objectives of the MHRA are to:

- make an effective contribution to public health
- provide authoritative and accessible information
- influence international regulation
- support industry and scientific innovation
- operate a successful and a fully integrated business
- minimise the cost of regulation.

The main activities of the MHRA are:

- assessing the safety, quality and efficacy and authorising medicines sold or supplied in the UK for human use
- overseeing the Notified Bodies that audit device manufacturers
- operating post-marketing surveillance and other systems for reporting, investigating and monitoring adverse reactions to medicines and adverse incidents involving medical devices and taking and necessary action to safeguard public health, for example, through safety warnings on the packaging of the centrifuge tubes or the improvement of designs
- operating a surveillance system to sample and test medicines and to address quality defects, monitoring the safety and quality of imported unlicensed medicines and investigating internet sales and potential counterfeiting of medicines
- regulating clinical trials of medicines and medical devices
- monitoring and ensuring compliance with statutory obligations relating to medicines and devices through inspection, taking enforcement action where necessary
- promoting good practice in the safe use of medicines and devices
- managing the General Practice Research Database (GPRD), the British Pharmacopoeia (BP) and the Device Evaluation Service, and contributing to the development of performance standards for medical devices.

Although a very simple product, the centrifuge tube is still governed by this legislation. This agency has influenced the design and manufacture of this product.



## **Medical specimen containers for microbiology**

The centrifuge tube design has to ensure the maximum capacity specified on the tube is adhered to while considering the dimensions of the tubes, as they must fit a standard centrifuge machine so there is a maximum dimension that the tube must not exceed. The way the cap fits on to the tube itself is also governed by this legislation. When tubes are tilted at an angle they must also conform to these regulations, all to safeguard the health of the public. The MHRA work very closely with British Standards and also influence the requirements of standards.

For instance the company will now ensure that the centrifuge tube will comply to BS 5213 — Medical specimen containers for microbiology. All of the areas mentioned above will have to conform to requirements laid down in this standard. This standard has paid particular attention to minimise the health hazard arising from leakage, from fine spray or from the spread of airborne particles when opening a container holding a solution.

### **The screwthread**

The screwthread of the tube has to comply with this legislation as laid down by BS 5789, particularly the finish and profiles. The standard sets out specific dimensions, in tabulated form, that the thread must comply to. These dimensions must be maintained throughout the working life of the centrifuge tube. It also mentions that sealing surfaces shall be regular and smooth as possible and the edges are not to be sharp as to be liable to cut into the seal and create a leak. The other area that has influenced the design is the air space between the surface of the liquid and the cap. If air space is insufficient, the internal pressure generated when there is an increase in temperature may be sufficient to break the container or lift the cap from its seal causing product contamination or degradation.

### **Sterilisation**

A sterile product is one that is free of viable micro-organisms. Medical devices require, when it is necessary to supply a sterile product, that microbiological contamination is minimised by all practical means. Even so, products produced under standard manufacturing conditions have micro-organisms on them prior to sterilisation. Such products are non-sterile. This will be the case for the centrifuge tube. Therefore these tubes will require deactivating microbiological contaminants and thereby transforming a non-sterile product into a sterile one. The process used to sterilise the tubes is by radiation.

Radiation sterilisation is a physical process, involving the exposure of a product to high energy radiation. The product packaged in sealed units is exposed, in specially designed equipment, to gamma rays from cobalt 60 or caesium 137 radionuclides, or to a beam from an electron generator.

The company is also influenced by BS EN 552:1992 — Sterilisation of medical devices. This standard describes the requirements for assuring that the activities associated with the process of radiation sterilisation are properly performed. These activities comprise documented work programmes designed to demonstrate that radiation sterilisation processes will consistently treat products with minimum and maximum doses.

Below you can also see a product performance evaluation sheet used for the Centrifuge Tube.

**WORK INSTRUCTION:** PRODUCT PERFORMANCE EVALUATION

**Number:** WIQ0012

**Date:** 07.10.03

**Rev:** 001

**Page:** 1 of 2

**RAISED:** PHILLIP DAVIES

QUALITY ASSURANCE MANAGER

**APPROVED:** PHILLIP DAVIES

TECHNICAL DEVELOPMENT MANAGER

**1.0 PURPOSE**

This work instruction defines the method of evaluating a competitor's product, new products, (ie products developed in-house) and enhancement of existing products.

**2.0 INTRODUCTION**

This procedure gives instructions on registration, recording results of samples received by the laboratory, and provides a means of evaluating the product in terms of functionality and performance against the specification.

**3.0 WORK INSTRUCTION**

**RESPONSIBILITY**

Quality Assurance Manager/Development Manager

**ACTION**

- 1 Decide test route for samples received using Product Evaluation Form QF329.
- 2 Inform laboratory assistants of samples to be registered.
- 3 Register Samples.

Laboratory Personnel

## CONTAINERS

- 1 The following tests are to be carried out:
  - Packaging and presentation assessment – 100% Visual Inspection
  - British Standard Leak Test – BS 5213: 1975.
  - Methylene Blue Leak Test.
  - Sterility Tests – WIQ004
  - Off Torques Testing
  - Centrifuge Testing
  - Effects of Irradiation
  - Print Durability
- 2 Results are to be collected and included in a written report and issued to the relevant personnel. Using Container Visual Report Form No. QF174, and Container Test Report Form No. QF219, record all results and pass onto the Quality Assurance Manager.

## Confidentiality agreement

Many companies today exchange confidentiality agreements to prevent each other from discussing products made within each company or even developing products any further. This is a piece of legislation drawn up by the company that would apply to this product. Below is a template to show such an agreement.

### CONFIDENTIALITY AGREEMENT

**THIS AGREEMENT** is made the xxth day of XX

#### **BETWEEN**

Company name; and x of x (hereinafter called 'x') of the other part.

**WHEREAS the company** and x intend to disclose to each other certain confidential information relating to 'x' hereinafter called '**The Project**'

**NOW THEREFORE** it is hereby agreed as follows:

- 1 For the purposes of this Agreement 'Confidential Information' shall mean all data, drawings, formulations, documentation and information of all kinds and in whatsoever form given by one party hereto to the other.
- 2 This Agreement shall commence on the date hereof and shall continue in force for a period of one year and thereafter for such other period as the parties hereto shall agree in writing.
- 3 All Confidential Information disclosed hereunder shall be identified and marked as such by the disclosing party. The recipient party shall in respect of any or all Confidential Information disclosed to it use the same only in connection with the Project and keep the same in confidence and not disclose it to any third party or other individual or company or to any of its employees not connected with the Project.
- 4 The foregoing obligations of confidentiality shall not apply to Confidential Information which:
  - a now or hereafter comes into the public domain otherwise than by breach of this agreement
  - b is in the possession of the recipient party at the same time of disclosure
  - c is subsequently disclosed to the recipient party by a third party without restriction as to use or disclosure.
- 5 The requirement of confidentiality as provided herein shall continue in force for a period of three months following termination of this Agreement.
- 6 This Agreement shall be construed in accordance with the law of England.

Signed on behalf of **Company Name**

.....

## Overall performance for assessment criteria (c)

*How appropriate legislation and standards influenced the design and/or manufacture of the engineered product or service.*

Jodie has identified and explained some of the relevant legislation that has influenced the design of the Centrifuge Tube by looking at the role played by the MHRA. She has also identified and explained a number of the relevant standards that apply to this product such as BS 5213 – Containers for Microbiology. She has also shown how the legislation has influenced the standards required to safeguard public health. However considering that in the previous section (b) Jodie had described engineering drawings and production machinery, it is surprising that she has failed to identify any regulations or standards which apply to these areas. The engineering drawings attached to that section should have led Jodie to a number of British Standards, including BS8888, and the mention of production equipment to Health and Safety Regulations, COSHH Regulations and the Electricity at Work Act.

Jodie has used technical language accurately, and communicated her information in a well laid out and well reasoned way.

Therefore Jodie's work meets the requirements of mark band 2.

## Exemplar student response for assessment criteria (d)

*How appropriate health and safety standards used by the engineer influenced the design and/or manufacture of the engineered product or service.*

The basis of British health and safety law is the Health and Safety at Work Act 1974. The Act sets out general duties that employers have towards employees and members of the public, and employees have to themselves and to each other.

These duties are qualified in the Act by the principle of '*so far as is reasonably practicable*'. In other words, an employer does not have to take measures to avoid or reduce the risk if they are technically impossible or if the time, trouble or cost of the measures would grossly disproportionate to the risk.

What the law requires here is what good management and common sense would lead employers to do anyway: that is, to look at what the risks are and take sensible measures to tackle them.

When the SDE sets about designing the centrifuge tube, he needs to consider the product function and performance. This particular product is classed as a medical device as we have seen from earlier there are British Standards that need to be adhered to. This product will be used in a laboratory for mixing a variety of solutions. The SDE has to consider the health and safety implications for the Laboratory Technicians. The tubes are subject to 'g' forces in excess of 6000g. The SDE has to consider what would happen if the tube were to crack or break at this kind of speed? The tubes could contain toxic chemicals or skin irritants that could cause serious injury to the technician, therefore the SDE has to consider the material for the tube very carefully so that it will withstand these kinds of speeds. As described earlier, the specific material most suitable for this tube is polypropylene. This has a high resistance to most harmful solutions. However, the laboratory technician will need to take reasonable precautions to prevent injury to himself or others by ensuring that eye protection is worn during handling. Also the use of laboratory overalls and in some cases where irritants are used, the use of gloves is essential. This form of protection is provided by the company in conjunction with the Health and Safety Act.

Another problem the SDE faces is preventing a leak from the cap of the centrifuge tube. The cap is required to have a seal which will mate with the inside face of the centrifuge tube. This must produce a seal to prevent leakage when handling or spinning. The SDE has to consider this when designing the injection moulding tool. Due to the nature of the polypropylene and most other polymers, there is a shrinkage allowance that is created when the polymer is heated and then cools. The SDE has to take this shrinkage allowance in to account to ensure the seal is produced. The SDE will have to carry out a Risk Assessment in case of leakage during the products working life.

### **Risk Assessment**

A Risk Assessment is nothing more than a careful examination of what, in the workplace, could cause harm to people, so that the employer can weigh up whether they have taken enough precautions or should do more to prevent harm. The aim is to make sure that no one gets hurt or becomes ill.

Accidents or ill health can cause a number of problems:

- they can ruin lives
- they can affect the company in terms of lost output
- machinery can become damaged
- insurance costs go up
- legal action may be taken against the company.

An employer is legally required to assess the risks in the workplace. The key to Risk Assessment is deciding whether a hazard is significant and that satisfactory precautions have been taken to ensure the risk is small.

The SDE at this company has carried out the following Risk Assessments for the design and manufacture of the centrifuge tube.

**WORK INSTRUCTION: RISK ASSESSMENT**

**Number:** RA172  
**Date:** 06/10/02  
**Revised:** 001

**RAISED:** SENIOR DEVELOPMENT ENGINEER  
**APPROVED:** TECHNICAL DEVELOPMENT MANAGER

RISK ASSESSMENT	ASSESSMENT UNDERTAKEN	ASSESSMENT REVIEW
Company name:		
Company address:	Date: 6/10/02	
	Signed: A.N.Other	Date: 10/12/02
	Date: 6/10/02	
Postcode:		

Significant hazard:	Identify groups of people who are at risk from significant hazard:	List existing controls or risks where action is needed:
1 Tube cracking or breaking	Laboratory Technicians	Materials used to manufacture tube must have a Certificate of Compliance. Technicians to wear eye protection, lab coats and gloves when handling tubes.
2 Leakage from the tube	Laboratory Technicians	Apply correct shrinkage allowance to appropriate polymer.
3 Using a VDU	Senior Development Engineer and Office Staff	Use a screen filter to prevent screen glare. Adjust seating position to provide comfortable working height. Take regular breaks when working for prolonged periods of time.

### **Employee safety during manufacture**

Whilst there are health and safety issues related to the design of the tube, there are also a number of health and safety issues relevant to the manufacture of the product that the SDE needs to consider. As an injection moulding tool is to be manufactured then the toolmakers will be using workshop machinery. The SDE has to assess the risks involved, such as the use of milling machines, lathes and grinders.

Various parts of the injection moulding tool will require manufacture by spark erosion. This process involves the use of a copper or graphite electrode to remove material from parts of the mould that are difficult to machine by conventional methods. The toolmakers have the same risks whilst using conventional machinery as described overleaf. They also have the risks involved with the spark erosion such as electric shock and fumes from the electrolytic solution used to aid the process. Again a Risk Assessment will be carried out as shown overleaf.



**WORK INSTRUCTION:**

RISK ASSESSMENT – CONVENTIONAL MACHINES

Number: RA173

Date: 06/11/02

Revised: 001

**RAISED:** SENIOR DEVELOPMENT ENGINEER  
**APPROVED:** TECHNICAL DEVELOPMENT MANAGER

RISK ASSESSMENT	ASSESSMENT UNDERTAKEN	ASSESSMENT REVIEW
Company name:		
Company address:	Date: 6/11/02	
	Signed: A.N.Other	Date: 15/02/03
	Date: 6/11/02	
Postcode:		

Significant hazard:	Identify groups of people who are at risk from significant hazard:	List existing controls or risks where action is needed:
1 Use of the milling machine	Toolmakers	Wear eye protection to prevent waste material entering the eye. Wear overalls to prevent damage to clothing. Ensure fingers are kept away from cutting area. Wear protective shoes to prevent injury to foot.
2 Use of the Lathe	Toolmakers	Wear eye protection to prevent waste material entering the eye. Wear overalls to prevent damage to clothing. Ensure fingers are kept away from cutting area. Wear protective shoes to prevent injury to foot.
3 Use of Grinding Machine	Toolmakers	Wear eye protection to prevent waste material entering the eye. Wear overalls to prevent damage to clothing. Ensure fingers are kept away from cutting area. Wear protective shoes to prevent injury to foot.

**WORK INSTRUCTION:**

RISK ASSESSMENT — SPARK EROSION

**Number:** RA176**Date:** 04/12/02**Revised:** 001**RAISED:**

SENIOR DEVELOPMENT ENGINEER

**APPROVED:**

TECHNICAL DEVELOPMENT MANAGER

RISK ASSESSMENT	ASSESSMENT UNDERTAKEN	ASSESSMENT REVIEW
Company name:		
Company address:	Date: 4/12/02	
	Signed: A.N. Other	Date: 5/03/03
Postcode:	Date: 4/12/02	

Significant hazard:	Identify groups of people who are at risk from significant hazard:	List existing controls or risks where action is needed:
1 Use of the spark erosion machine.	Toolmakers	Keep hands out of the tank where erosion process is taking place. Ensure area is well ventilated and electrodes are submerged completely in electrolytic solution.

As already mentioned, the product is going to be manufactured using injection moulding. The company has to consider health and safety implications with regard to products during the manufacturing stage. Again the SDE would carry out a risk assessment for these machines to determine hazards that could occur whether it's from one of the production workers or the machine setter. The Moulding machine itself heats up the polypropylene to temperatures around 250 degrees Celsius. The barrel needs to be protected to prevent an employee from burning themselves during manufacture. Areas of extreme heat are protected with guards. However, the other risk concerned with injection moulding machines is noise pollution. Having been in the offices that are directly below the production area, there is a pounding noise created by the mould opening and closing. This cycle continues throughout the whole working day as the demand for these products means the process is virtually continuous, only stopping for essential maintenance. The actual production area can be very noisy. With up to six machines operating at full capacity throughout the day, the company monitors the level of noise on a regular basis. If the level of noise is between 85 and 90 decibels, if the employee requires ear protection then it must be supplied. If the noise level is above 90 decibels then the employee must be provided with ear protection.

### **Material choice**

The SDE needs to choose the material carefully, not only to prevent chemical attack from the solution the centrifuge tubes will hold; but to safeguard the production workers when the polypropylene is being used to manufacture the product. The material chosen will have an accurate data sheet showing its mechanical properties. The SDE will also ensure that the material is processed within the recommendations developed by the material supplier. There are particular problems associated with polymers when injection moulding such as preventing the material from overheating or standing too long in the barrel of the machine. Both would produce a breakdown of material and gases would build up within the barrel resulting in a potentially explosive situation.

## Overall performance for assessment criteria (d)

*How appropriate health and safety standards used by the engineer influenced the design and/or manufacture of the engineered product or service.*

Jodie has identified and explained relevant Health and Safety Standards that have influenced, in this case, both the manufacture and design of the centrifuge tube. She has given details of risk assessment related to the product and the precautions needed to protect employees to enable manufacturing to take place. There is also evidence that the engineer has considered the health and safety of the intended user in the form of how the tube reacts in the working environment. Jodie did not however give details of how the health and safety issues were, or would be, monitored. For example, how would the company measure the effect of noise pollution in the production area when machines are at full capacity. Had this area been covered then Jodie's work could have met the requirements for mark band 3. Jodie has again demonstrated good communication skills and used technical terms and language correctly. The quality of the work suggests that it was the independent work of an individual student.

Therefore Jodie's work meets the requirements of mark band 2.

Please note that it is not a requirement to include risk assessments, but Jodie has included them as a useful vehicle for bringing out/demonstrating her understanding of the relevant points.

## Exemplar student response for assessment criteria (e)

*Evaluation of the performance of the engineered product or service you have investigated for its being fit for purpose.*

The centrifuge tube has been designed to hold a variety of solutions in a sterile condition. The SDE has allowed me to carry out a number of tests to evaluate the intended performance of the centrifuge tube with the following specification points in mind:

- the product must fit a standard centrifuge machine
- it must withstand a centrifugal force of 6000g
- it must be resistant to attack from numerous chemicals and substances used in a wide range of laboratories
- the product must be able to be supplied sterile if required
- a secure sealing cap must be fitted that can be easily removed
- the product must be capable of mass production
- the product must resist impact from a height of 2 metres
- all printing on the tube must be resistant to a variety of solutions.

### **Centrifuge machine fit**

This test is carried out to ensure that the tube will fit a standard centrifuge machine. If this test fails then the product has to be modified. It involves placing a random sample of tubes into the racks of the centrifuge machine and then assessing the fit.

#### *Results*

I tested 20 tubes in all four ports in the machine. Due to the production method of injection moulding there was consistency in tube dimensions that produced a good fit inside each of the ports. When designing the tooling, the SDE must ensure that tolerances are very small to create accurate mouldings.

### **Centrifuge test**

The test will determine whether the centrifuge tube will withstand centrifugation when at full capacity. The test involved filling the tube with a water solution to its maximum capacity, in this case 50ml. The cap was then hand torqued on to the tube. The tube was placed in the bucket of the centrifuge machine ensuring that each side of the machine was correctly balanced. The drum cap was then placed on to the centrifuge drum and the centrifuge lid was then closed. The centrifuge machine was then spun to the required speed, that is, 6000g. This would last for a minimum of five minutes. Once centrifugation was complete, the tubes were removed and carefully checked for cracks.

#### *Results*

Each of the tubes was inspected using ultra-violet light. I could see no evidence of cracking whatsoever. As the tubes were filled to capacity there was no evidence of any leaks either. This is a direct result of the material selected, Polypropylene, and the experience of the SDE to provide a material fit for its purpose.

## **Material choice**

As specified in an earlier part of the assignment, the material choice has been made from years of testing by the material suppliers. The SDE uses the material supplier's website to obtain an appropriate material for the tube. The material chosen will have an accurate data sheet provided with it detailing what solutions can be used with polypropylene.

## **Off torque test**

This test is used to determine the limits that the cap will take to prevent overtightening and becoming damaged. The centrifuge tube was gripped in the torque meter under a constant pressure. The needle of the meter was then set to zero to act as a datum. The cap was then unscrewed from the container and a reading taken from the dial. The tubes would be tightened at different torque levels and then the force needed to remove the cap would be evaluated.

### *Results*

The company has determined a torque setting of 6.5lb inches as the correct value for the cap fitting. When I tested the samples with a higher torque setting, it was difficult to remove the cap with one hand. Any torque settings lower than 6lb inches meant the cap was too loose and a seal was not created between tube and cap.

## **Leak testing**

This test involves the use of Methylene Blue powder to test for leaks on the centrifuge tube. The process required dissolving 10g of Methylene Blue in 1000ml of water. The solution was then mixed using a magnetic stirrer on a gentle speed. The stock solution needs to be diluted in a ratio 1:2 to form a working solution. The centrifuge tube was then filled with the solution to 50% of the nominal volume, in this case 25ml. The cap was then fitted and left inverted in a beaker of water for a minimum of six hours at 20 degrees Celsius, ensuring the cap is fully immersed in water. This test would be used before and after the centrifuge test.

### *Results*

On inspection of the container, the water had become discoloured in nearly all of the samples. The water had turned a lime green as a result of the solution inside the tubes escaping. In this particular test, batch testing comes in to effect. A certain quantity of tubes are tested in a batch, in this case ten, if 2 of these show signs of leaking then the whole batch is rejected. Therefore the tubes in this particular batch need modifications.

## **Mass production**

On visiting the production workshop, I had the opportunity to view the injection-moulding machine in operation. There I could see the speed at which these tubes could be produced. This four-impression mould was capable of turning out 16 tubes per minute, all of the same high quality. With a shift pattern covering the 24-hour day it is possible for the machine to produce more than 115,000 tubes in a week. I think that clearly qualifies for mass production capability. This was evaluated on the expected requirements of the customer against the internal production capacity of the company.

## **Drop test**

This test was carried out to determine the impact strength of the centrifuge tube. It involved filling the tube with water to maximum capacity and then hand torque the cap securely. The sample was then kept in a freezer for 24 hours prior to testing. It was then dropped on to a concrete floor from a height of 3m. This height being determined by the maximum height the tubes would be stored when full. The tubes were then checked for damage after impact. A tube was also used to guide the drop of the sample ensuring different parts of the tube were tested for impact.

### *Results*

On inspection, out of the 10 that were tested, only one of these showed any kind of stress upon the outside surface of the tube. However, this did not produce a crack, just mild scratching of the surface. In fact on a number of occasions the tube bounced and the material seemed to absorb the shock of the impact.

### **Print durability**

This test is to ensure that any printing on the surface of the tube would not come off during working conditions to prevent inaccurate measurements of solutions. This test involved a random sample of ten centrifuge containers. Five of these tubes were then placed in 70% Isopropanol solution ensuring all the print is covered and then they were left for five minutes. The tubes were then rinsed under running water and examined for any loss of print. The other five tubes were then placed in Sodium Hydroxide ensuring all the print is covered and then they were left for five minutes. The tubes were then rinsed under running water, rubbed with a dry cloth and examined for any loss of print. These are aggressive substances that attack or breakdown the ink but not the material for the tube. All of the writing and numbering must be complete. Predetermined working samples of the minimum quality of print are available for the inspection team to compare against.

### *Results*

On inspection all of the samples were clearly visible. Any that had minor loss of print were compared with the predetermined samples and the company passed all.

### **Stand test**

This test is used to determine the stability of the tube during laboratory conditions. The test specifies that each tube, when at full capacity should be able to be tilted at an angle of 15 degrees without it falling over. This test was carried out with a random sample of 20 tubes.

Due to the nature shape of the base as illustrated in the drawing overleaf, you can see that this test was not possible even at five degrees. The pointed nature of tube made it almost impossible to tilt at any angle before it fell over. This device was possible to tilt while resting in a rack or while under centrifugation, but not free standing. This could become a hazard within the laboratory if there are no racks available to store tubes containing solutions.

### **Capping test**

When the centrifuge tubes are used within the laboratory, it is necessary for the technicians to fit and remove the cap in one hand. Often the technician will use one hand to hold the tube, whilst using the other hand to apply substances via a pipette or other laboratory instruments such as a hand stirrer. Therefore the cap needs to be fitted and removed easily using just the thumb and index finger. This test involved the use of both these fingers to fit and remove the cap, to check if the cap sits correctly on the thread and to see how long it takes to fit and remove.

### *Results*

This test proved quite a challenge as I found it very difficult to get the lid on and off. There was quite a lot of strength required in the thumb and index finger to tighten the cap and then loosen it. Also I had difficulty in aligning the cap with the tube itself. On nearly every tube I tested the cap went on at angle preventing a good seal and also this added to the time for the process to be completed.

## Overall performance for assessment criteria (e)

*Evaluation of the performance of the engineered product or service you have investigated for its being fit for purpose.*

Jodie has produced a thorough and complete description describing the testing of the product against the specification. Each part of the specification has been evaluated against the fitness for purpose and intended use. She has explained in detail the difficulties centred on the single hand use of the tube and provided objective statements. It is clear that the candidate has gained a good understanding of the product, and the way it is actually tested and used. The evaluation is accurately based on the issues surrounding the specification. The information is communicated well, using appropriate technical language. It also appears to represent independent work, although it is clearly based on information provided by the company.

Jodie could have obtained opinions about the intended use and fitness for purpose from the laboratory technicians or the customer, which would have helped to justify awarding marks higher up the mark band. Obtaining their point of view as experienced practitioners would have generated a greater understanding of any problems associated with the product such as the square fit required when closing the lid with one hand to create a good seal.

Therefore Jodie's work meets the requirements of the lower end of mark band 3.



## Exemplar student response for assessment criteria (f)

*Suggestions for possible modifications to improve the performance outcome of the engineered product or service.*

As a result of testing, there were a number of areas that I felt needed to be modified.

### **Centrifuge tube leaks**

As we have seen from the test results earlier there were quite a few leaks from the centrifuge tubes and in discussions with the SDE, it looks likely to be the seal on the underside of the cap. There can sometimes be insufficient mating of the seal and tube walls creating a small area from which solutions are leaking.

### **Cap squareness**

There were a number of occasions when the cap did not fit squarely on the top of the tube. This also added to the leak problem. There was a mis-alignment with the single start thread that then prevented the cap from sitting on the top of the tube. Also this caused the seal to become trapped between the cap and the tube end creating permanent damage to the seal.

### **Fitting and removal time**

Some capping tests resulted in lengthy fitting and removal times due to an inability to get the thread square. Technicians need to be able to get the cap on and off as quickly and as easily as possible to minimise contamination of any solution entering the tube.

### **Modifications**

In discussion with the engineer, the problem lay with a single start thread. It was proposed that the new tubes should possess a two-start thread. This would allow for a true fit and removal whilst increasing the speed of the action and producing a better seal between cap and tube. The two-start thread will naturally hold the cap square, as there is two-point contact at opposite sides of the tube and cap.

As an extra feature, the seal would also be modified to accommodate the new two-start thread and further reduce risk of leakage as seen in the diagram below.

When I tried to fit and remove the cap using one hand I felt that I was unable to grip the cap easily. The size of the cap was fine but the serrations to aid gripping were a little too shallow. I would propose that these serrations be taken deeper, approximately 0.5mm on the diameter of the cap to give some extra grip when twisting.

### **Stand test**

There was a severe problem with this test. None of the tubes tested were able to stand freely at an angle of 15 degrees. These tubes were purely designed for use with a rack or positioning in a centrifuge machine. In discussion with the laboratory technicians who use these tubes, it was felt that there was a need to have these tubes free standing. The diameter and length of the tubes could not be altered, as they have to fit a standard centrifuge machine. So the introduction of a skirt could be possible as seen in the drawing below. Here, a rim of polypropylene has been added around the cone effect at the base of the tube without any alteration to its length or diameter. These additional changes would be incorporated in the design and manufacture of the injection-moulding tool. The skirt has been kept hollow to reduce weight and prevent sink marks that would appear if the base were solid.

### **Conclusions**

The centrifuge tube has been a very successful product for many years and production of this vital piece of equipment is virtually continuous due to the demand. The suggestions for modifications listed above can only improve the quality and reliability of the product.

**EXISTING THREAD  
PITCH 4.26  
1.5 TURNS OF THREAD**

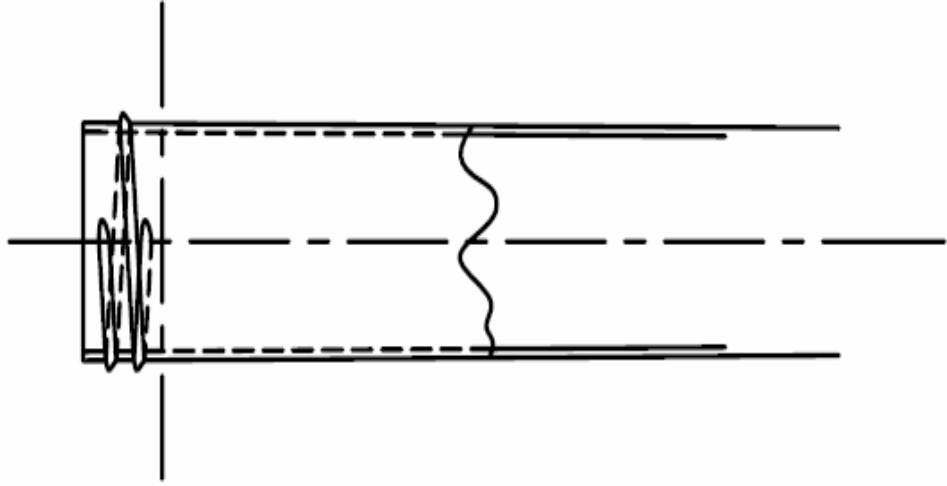

**TWO START THREAD**  
**PITCH 3.125**  
**LEAD 6.25**

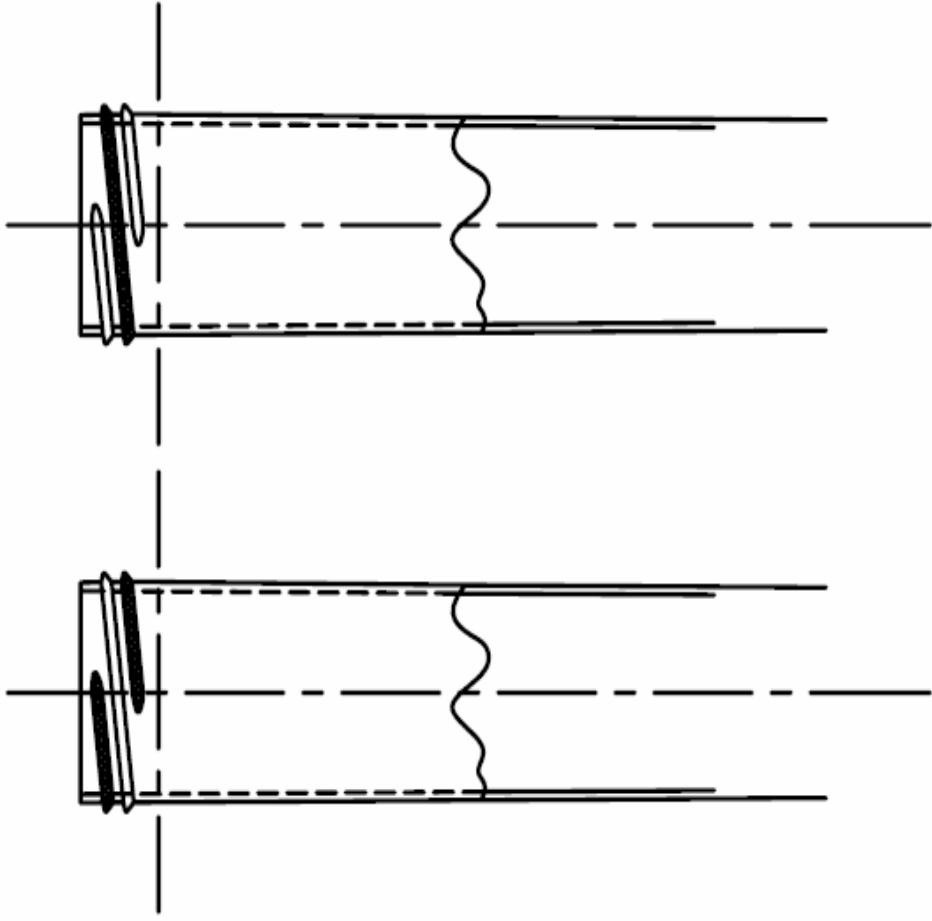



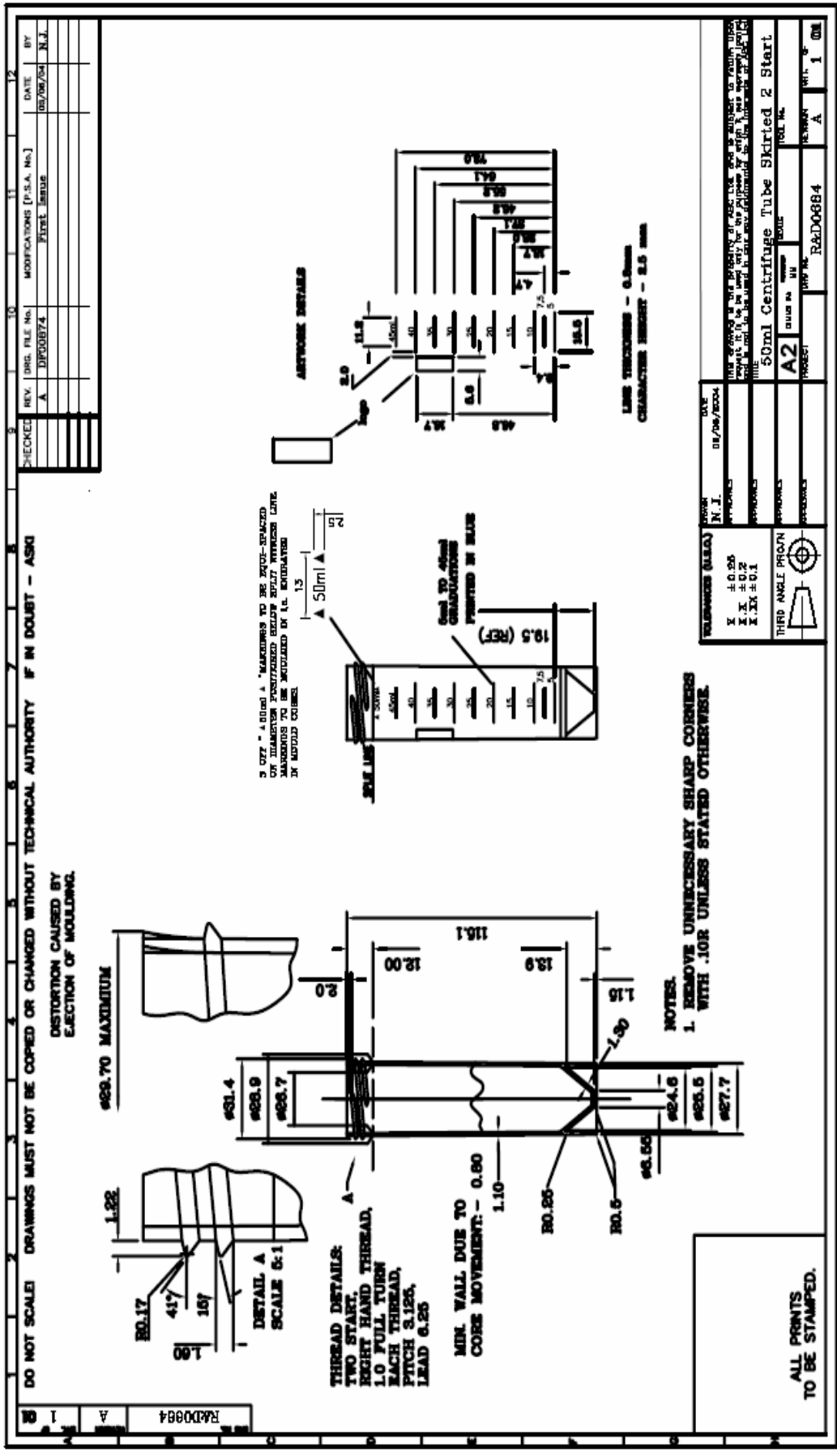

DO NOT SCALE! DRAWINGS MUST NOT BE COPIED OR CHANGED WITHOUT TECHNICAL AUTHORITY IF IN DOUBT - ASK

DISTORTION CAUSED BY EJECTION OF MOULDING.

68.70 MAXIMUM

DETAIL A SCALE 6:1

THREAD DETAILS: TWO START, RIGHT HAND THREAD, 1.0 FULL TURN EACH THREAD, PITCH 3.125, LEAD 6.25

MIN. WALL DUE TO CORE MOVEMENT: - 0.80

1.10

68.25

68.6

68.5

68.6

68.7

68.8

68.9

69.0

69.1

69.2

69.3

69.4

69.5

69.6

69.7

69.8

69.9

70.0

70.1

70.2

70.3

70.4

30.17

41.7

167

1.8

1.22

68.17

68.4

68.9

68.7

68.4

68.9

68.7

68.4

68.9

68.7

68.4

68.9

68.7

68.4

68.9

68.7

68.4

68.9

68.7

68.4

68.9

68.7

68.4

68.9

1.8

41.7

167

1.22

68.17

68.4

68.9

68.7

68.4

68.9

68.7

68.4

68.9

68.7

68.4

68.9

68.7

68.4

68.9

68.7

68.4

68.9

68.7

68.4

68.9

68.7

68.4

68.9

68.7

1.8

41.7

167

1.22

68.17

68.4

68.9

68.7

68.4

68.9

68.7

68.4

68.9

68.7

68.4

68.9

68.7

68.4

68.9

68.7

68.4

68.9

68.7

68.4

68.9

68.7

68.4

68.9

68.7

1.8

41.7

167

1.22

68.17

68.4

68.9

68.7

68.4

68.9

68.7

68.4

68.9

68.7

68.4

68.9

68.7

68.4

68.9

68.7

68.4

68.9

68.7

68.4

68.9

68.7

68.4

68.9

68.7

1.8

41.7

167

1.22

68.17

68.4

68.9

68.7

68.4

68.9

68.7

68.4

68.9

68.7

68.4

68.9

68.7

68.4

68.9

68.7

68.4

68.9

68.7

68.4

68.9

68.7

68.4

68.9

68.7

1.8

41.7

167

1.22

68.17

68.4

68.9

68.7

68.4

68.9

68.7

68.4

68.9

68.7

68.4

68.9

68.7

68.4

68.9

68.7

68.4

68.9

68.7

68.4

68.9

68.7

68.4

68.9

68.7

1.8

41.7

167

1.22

68.17

68.4

68.9

68.7

68.4

68.9

68.7

68.4

68.9

68.7

68.4

68.9

68.7

68.4

68.9

68.7

68.4

68.9

68.7

68.4

68.9

68.7

68.4

68.9

68.7

1.8

41.7

167

1.22

68.17

68.4

68.9

68.7

68.4

68.9

68.7

68.4

68.9

68.7

68.4

68.9

68.7

68.4

68.9

## Overall performance for assessment criteria (f)

*Suggestions for possible modifications to improve the performance outcome of the engineered product or service.*

Jodie has analysed the test results from the previous section and suggested modifications showing detail through the use of drawings. She has offered modifications to the thread and seal between the cap and tube to prevent any leaks. Also the use of a skirt to provide a stable product has clearly improved the performance of the product. The company has provided drawings, although not essential, but Jodie does refer to these drawings as a source of evidence. Jodie's work is well reasoned, and communicates the information well. It uses technical language appropriately. The information is clearly based on information and testing carried out by the manufacturer, but it does give the impression that this section is the result of being produced independently by the student.

Therefore Jodie's work meets the requirements of mark band 3.

## Unit 4: Applied Engineering Systems

### Activity 1

It is important for engineers to know the forces acting on the members of load-bearing structures and the strength of the materials from which they are made. In this activity you will be asked to carry out a destructive tensile test on a structural material to determine its load-bearing properties. You will also be asked to analyse a loaded framed structure to determine how its members react and whether it is in a safe condition.

You are required to complete the following tasks and submit evidence of your work.

#### Task 1:

Measure and record the behaviour of samples of low carbon steel when subjected to a destructive tensile test.

#### Task 2:

Plot a graph of stress v strain and from it determine:

- the ultimate tensile strength of the material
- the modulus of elasticity of the material.

The members of the structure in figure 1 are made from tubular section low carbon steel of the same composition as the material that you have tested. The outer diameter of the members is 50 mm and the wall thickness is 5 mm. You may assume that they are pin-jointed at their ends.

Figure 1

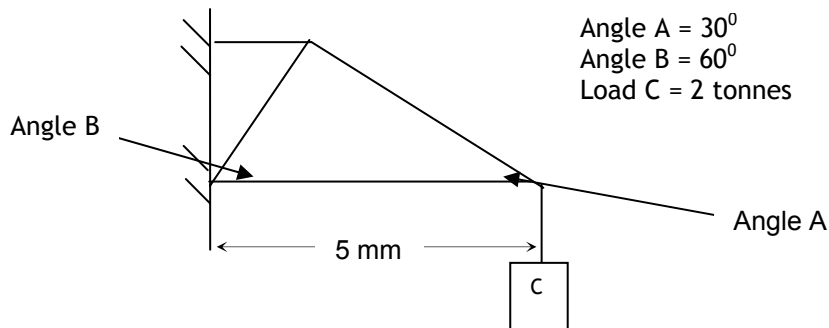

#### Task 3:

Determine the magnitude and nature of the forces present in the above structure.

#### Task 4:

Determine the factor of safety in operation.

#### Task 5:

Determine the dimensional changes that occur in the members as a result of the loading.

You may assume that the modulus of elasticity of the material is the same in tension and compression.

## Activity 2

Electro-mechanical systems are found in everyday life. They include domestic appliances, power tools and some items of laboratory and office equipment. In this activity you will be asked to explain the function and investigate the design of a given electro-mechanical system.

You are required to complete the following tasks and submit evidence of your work.

**Figure 2**



### **Task 1:**

Explain the overall purpose and function of the oscillating fan shown in *Figure 2*.

### **Task 2:**

Investigate the construction and operation of the fan and explain, with the aid of a labelled block diagram, how its sub-systems and components are interconnected.

Your diagram should clearly show the connecting pathways, the input and output of each block and any energy transfer/conversion that takes place.

### **Task 3:**

Provide a detailed example of an alternative design solution that might fulfil the same basic function and compare fitness for purpose.



### Activity 3

Process variables such as temperature, pressure, speed, light intensity etc often need to be monitored and controlled. In this activity you have to design a suitable monitoring or control system which fulfils the requirements of the given design brief.

#### Design brief

You are required to design an engineering system for the monitoring and control of temperature. The range that it must cover is 20-100°C. The degree of accuracy required is  $\pm 2.0^\circ\text{C}$ .

You are required to complete the following tasks and submit evidence of your work.

#### Task 1:

Produce a feasible design solution for the system. This should include appropriate block diagrams showing the system elements, signal pathways, inputs and outputs. It should also include a detailed explanation of how your system functions, meets the requirements of the design brief and takes into account health and safety considerations.

#### Task 2:

Select suitable materials and components for your design which take into account possible production constraints, cost constraints and safety considerations.

## Exemplar student response for assessment criteria (a)

Measure and record the behaviour of a structural material when subjected to a destructive tensile test. Process the data and determine the tensile strength and modulus of elasticity of the material. Determine the internal forces present in a loaded-framed structure. Calculate the factor of safety in operation and the dimensional changes caused by the loading.

### Activity 1

#### Task 1

Tensile test on three samples of EN324 low carbon steel:

Note that in each case the final value represents the final point at which the sample failed.

#### Sample 1

Sample length		100	mm
Sample diameter		5.195	mm
Force N	Extension mm	Area mm <sup>2</sup>	Stress N/mm <sup>2</sup>
0	0	21.2	0.0
2300	3	21.2	108.5
4600	6	21.2	217.0
6300	9	21.2	297.2
6600	12	21.2	311.3
6790	15	21.2	320.3
6800	18	21.2	320.8
6820	21	21.2	323.6
6860	24	21.2	323.6
6875	27	21.2	324.3

## Task 2

This graph shows the readings obtained by destructive testing on a tensometer.

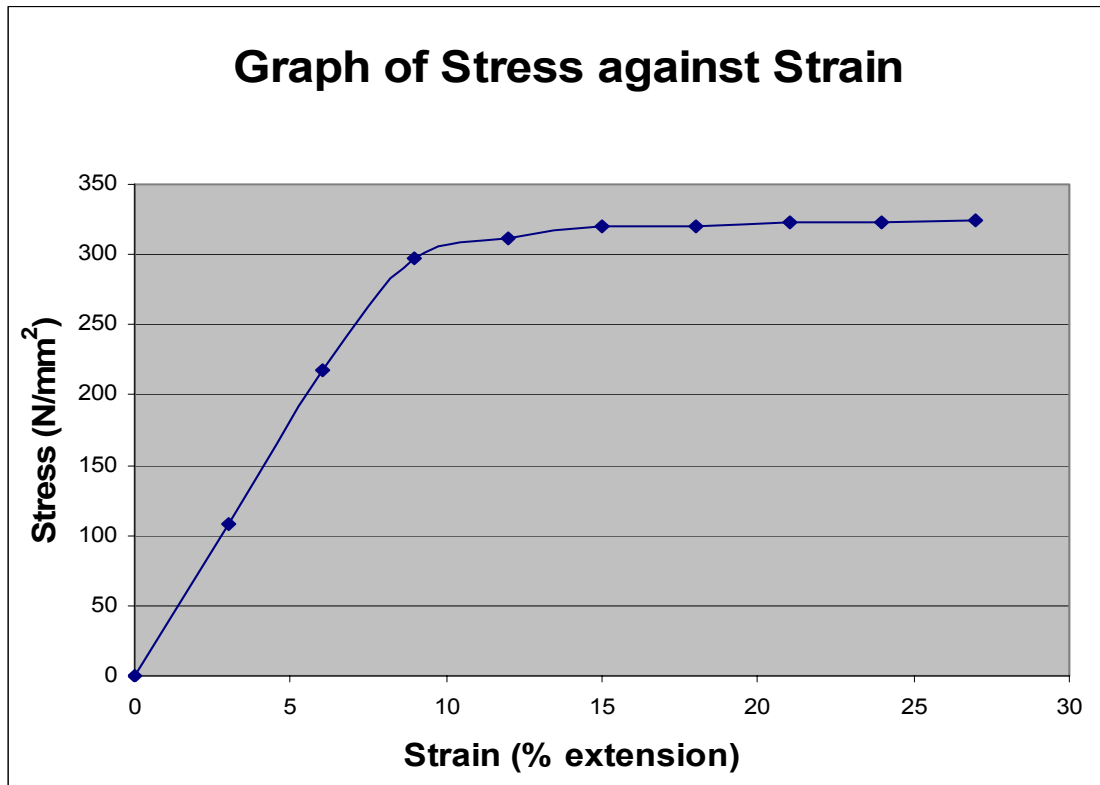

The ultimate tensile strength of the material is the maximum stress that the material can take just before it breaks.

In this case it is 324kNmm<sup>-2</sup>.

The modulus of elasticity of the material is given by the stress/strain relationship on that part of the graph where the slope is linear.

Slope of linear part of graph is  $(300-0)/(8-0)= 37.5$

In this case it is 37.5kN/mm.

### Task 3

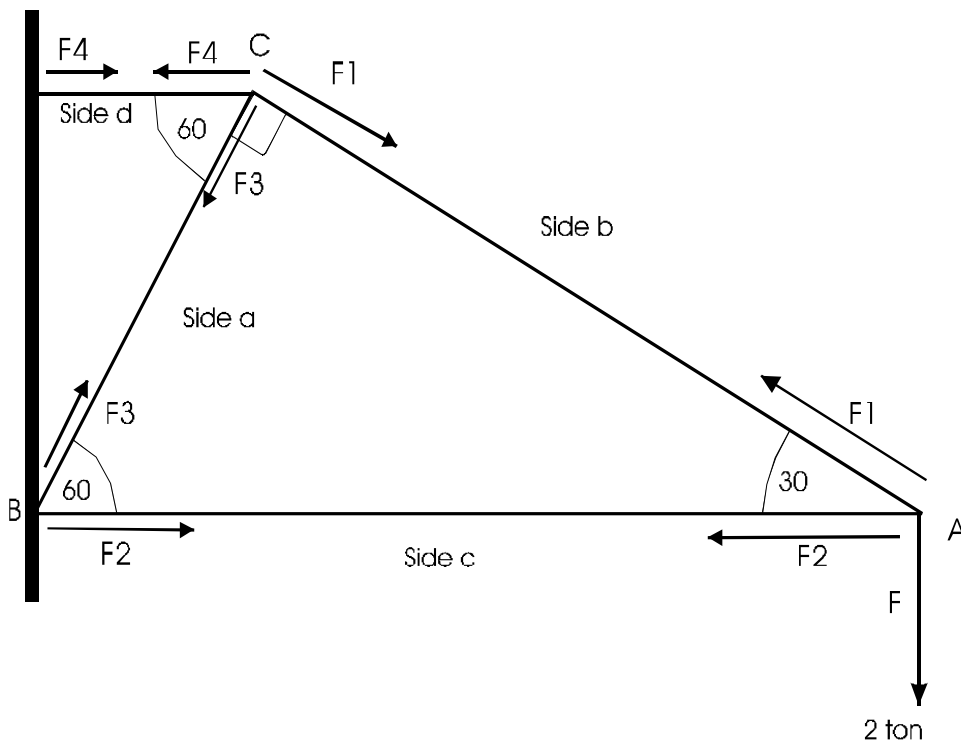

Force applied to the system due to the weight of the load is given by:  $F=ma$ , where 'm' is the mass suspended, and 'a' is the acceleration due to gravity.

Force due to weight =  $2000 \times 9.81 = 19620$  Newtons

Resolving forces at point A:

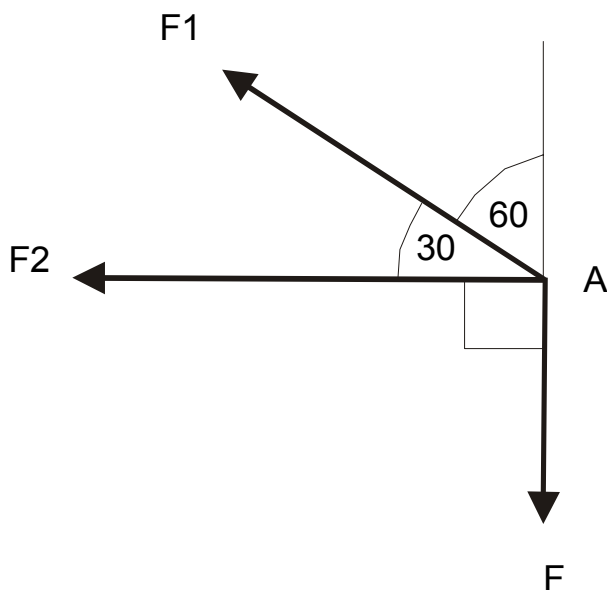

Resolving vertically

$$F/F_1 = \cos 60$$

$$\text{Therefore } F_1 = F / \cos 60 = 19620 / \cos 60$$

And  $F_1 = 39239.94$  Newtons. This member is in tension.

Resolving horizontally

$$F_2/F = \tan 60$$

$$\text{Therefore } F_2 = \tan 60 \times F = \tan 60 \times 19620$$

And  $F_2 = 33982.77$  Newtons. This member is in compression.

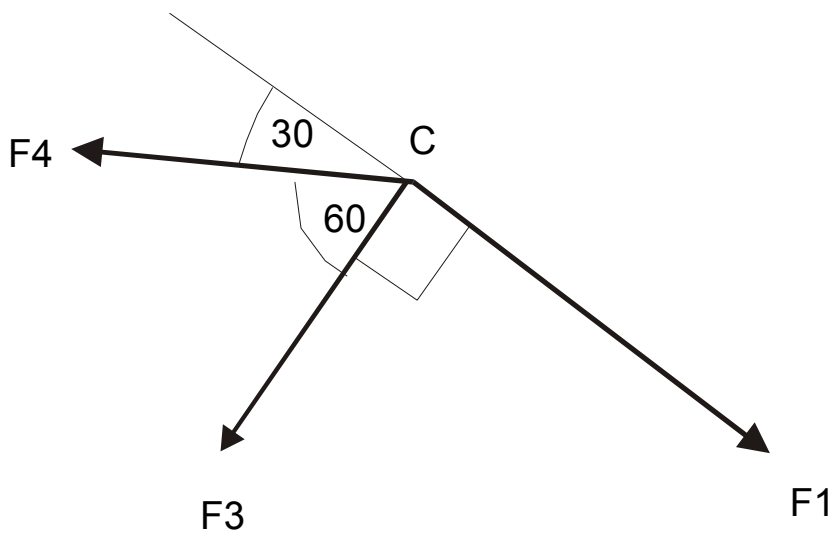

Resolving along the direction of beam AC

$$F_1/F_4 = \sin 30$$

$$\text{Therefore } F_4 = F_1 / \sin 30 = 39239.94 / \sin 30$$

And  $F_4 = 78479.94$  Newtons. This member is in tension.

Resolving perpendicular to the beam AC

$$F_3 / F_1 = \tan 30$$

$$\text{Therefore } F_3 = F_1 \times \tan 30 = 39239.94 \times \tan 30$$

And  $F_3 = 22655.17$  Newtons. This member is in compression.

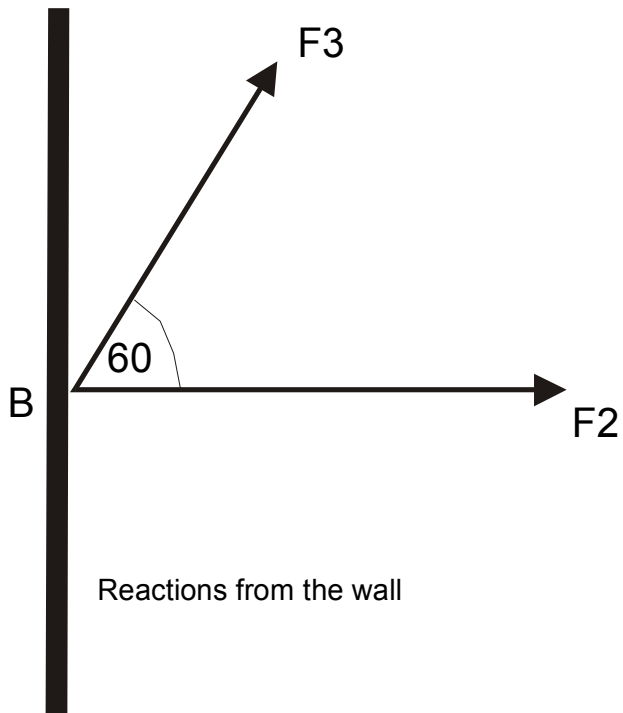

The forces acting at point B are already known, since F2 and F3 acting towards the point B must be opposed by equal and opposite forces from the fixed wall (if the system is to remain static).

So the forces acting at point B are

F3 = 22655.17 Newtons in compression

And F4 = 78479.94 Newtons in compression

#### Task 4

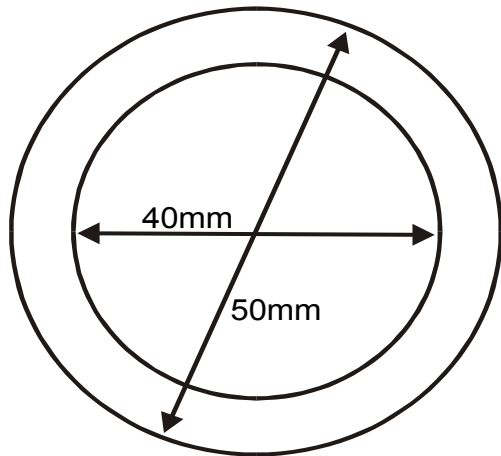

To find the cross sectional area of each part of the system:

Each member of the system is tubular with an outside diameter of 50mm, and a wall thickness of 5mm.

The Area of a 50mm diameter rod is given by  $A = \pi D^2/4$  in  $\text{mm}^2$

If the wall is 5mm thick then the inside diameter of the tube is 40mm.

The area of a 40mm diameter rod is given by  $a = \pi d^2/4$  in  $\text{mm}^2$

Therefore the c.s.a. of the tube is  $A-a = \pi D^2/4 - \pi d^2/4 = \pi(D^2 - d^2)/4$

$$= 3.14159 (50^2 - 40^2)/4$$

$$= 1963.49 - 1256.36 = 706.86 \text{ mm}^2 \text{ or } 0.000707\text{m}^2 (7.07 \times 10^{-4}\text{m}^2)$$

The greatest force in the framework is F4 N in member AC (tension).

Since all the members have the same cross sectional area then this must have the greatest stress within it.

Stress = force /c.s.a.

$$\text{Stress AC} = F4 / 706.86 = 78479.94/706.86 = 111.02 \text{ Nmm}^{-2} \text{ or } 111 \text{ MNm}^{-2}$$

Safety factor = actual stress/ultimate tensile stress as a per unit value

Safety factor =  $1.11 \times 10^8 / 323.3 \times 10^6 = 2.91$  to 1 in other words the actual stress in the member is about  $\frac{1}{3}$  of the maximum stress.

The safety factor is low, and would normally be expected to be 6 to 1 for a lifting machine. In other words the actual stress should be no more than  $\frac{1}{6}$  of the maximum stress.

### Task 5

Young's modulus from activity 1 is  $506.6 \times 10^8 \text{ Nmm}^{-2}$ .

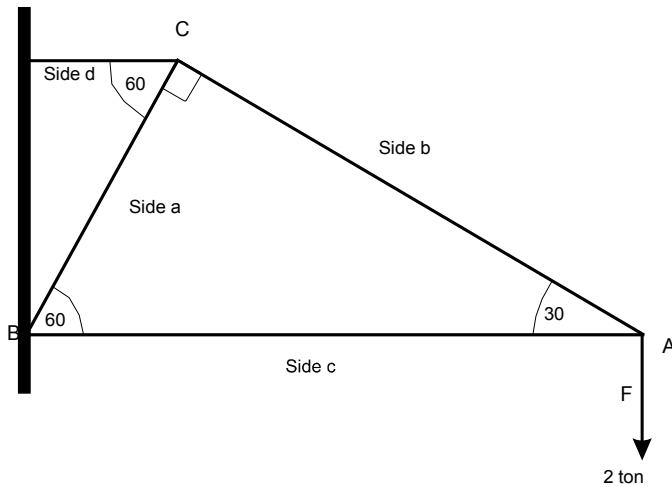

Length of side C (given) is 5 m

Length of side a =  $5 \sin 30 = 2.5\text{m}$

Length of side b =  $5 \cos 30 = 4.3\text{m}$

Length of side d =  $2.5 \cos 60 = 1.25\text{m}$

If young's modulus is  $505\text{Nmm}^{-2}$  then the extension in any side due to the force F in it is given by

$Y = \text{Stress in member} \times \text{original length} / \text{extension}$

Transposing gives  $e = \text{length} \times \text{stress} / \text{Young's modulus}$

$$e_b = 4.3 \times 1000 \times 55.5 / 506 = 0.00475 \text{ mm}$$

$$e_c = 0.004749 \text{ mm}$$

$$e_d = 0.00547 \text{ mm}$$

$$e_a = 0.00079 \text{ mm}$$



## Overall performance for assessment criteria (a)

*Measure and record the behaviour of a structural material when subjected to a destructive tensile test. Process the data and determine the tensile strength and modulus of elasticity of the material. Determine the internal forces present in a loaded-framed structure. Calculate the factor of safety in operation and the dimensional changes caused by the loading.*

John has produced work which shows that he understands the principles of tensile testing to destruction. He has correctly tabulated values which will enable him to calculate stress and strain at a number of relevant values of load. Note that there are about 10 separate values which have been measured. Also note that the values are sufficient for him to show the shape of the curve over its full extent from zero to the point when the sample was destroyed. However, there could have been more values measured, particularly in the area where the slope of the graph is linear, so that a more accurate slope for the gradient of the graph could have been obtained. A statement concerning the accuracy of the measuring instruments would have also helped to indicate experimental accuracy.

John has used a spreadsheet package to produce a graph of stress plotted against strain as he was asked to do. This is important since many students will be tempted to plot the values that they can see easily from the test equipment, namely load and extension. Note that students were required to plot stress against strain and not load against extension. So John has plotted the correct values. The graph has labels on the axes, as well as suitable values and appropriate units. It has a title, and is organised to fill the available space. The measured values are indicated by points on the graph and a smooth line joins the points indicating a line of best fit. It is probably as much as a student is likely to be able to produce in the time available, but some indication of error bands would have helped to indicate whether the values plotted were indicative of an actual trend in the graph, or whether the changes in value were insignificant compared to the error on the measurements. The graph demonstrates the type of relationship between stress and strain which would be expected for low carbon steel. John has successfully shown that he can use his graph to obtain values for factors which are relevant to the graph, thus demonstrating a knowledge and understanding of the principles of this type of test. The graph has been produced using a spreadsheet package for presentational clarity, but John could have actually plotted the graph by hand, and this might have encouraged him to add the error bars and to add extra points where the shape of the graph changed significantly.

John's analysis of the crane structure is theoretically correct and although it may contain a few mathematical errors it is sufficiently complete and correct to be regarded as a correct solution. He has used the values for the properties of the material that he obtained as a result of his experimental work. He has completed all of the tasks as set. He has provided values for extensions for each of the members, safety factor and stresses in each member. John would not have been penalised for making minor mathematical errors in this analysis, but would have obtained full marks for a well reasoned and developed analysis which was dimensionally accurate.

John has been awarded marks at the low end of mark band 3 for this section of his work. John has clearly demonstrated the required knowledge and understanding required to achieve the higher band marks for this activity. If John had taken more readings around the areas where the graph changed shape, and indicated error bands on his graph he would have been awarded the higher end marks.

## Exemplar student response for assessment criteria (b) and (c)

*Explain the function of a given electro-mechanical system.*

*Investigate the sub-systems and elements that comprise the given electro-mechanical system. Describe using a block diagram, their function, relationships and the transfer or conversion of energy that might occur.*

### Activity 2

Product evaluation of an oscillating fan

#### Task 1

Purpose:

To make a room feel cooler and more comfortable. Usually used during hot weather as a temporary solution to people feeling too hot. It may be used to help to draw fresh air into a room from an open window, but its main purpose is to generate air movement which will cool the occupants.

Function:

The fan's function is to blow air around the room, and it does this by converting electrical energy into air movement by using an electrical motor to turn fan blades which create a stream of moving air. The air movement is enhanced by moving the direction that the fan is facing from side to side thus ensuring that all areas of the room in which it is situated benefit from the forced air flow. The device does not actually cool the air in the room but it makes the room feel cooler.

This cooling effect relies upon the flow of air over the persons' skin helping to evaporate sweat from the surface of the body, hence cooling the body by removing the energy required to evaporate the liquid to a vapour.

This cooling effect may be particularly beneficial in making a room feel cooler when there is no natural flow of air from open windows, or when the air in the locality is itself slow moving due to lack of wind.

## Task 2

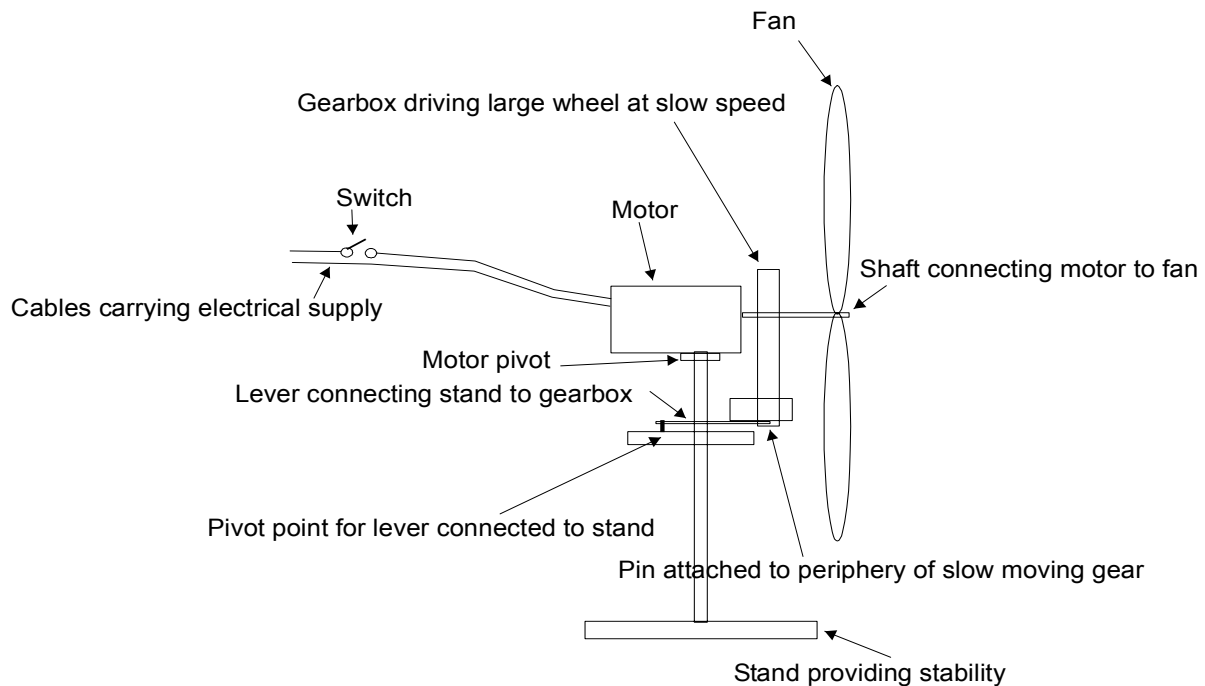

### Explanation of construction and operation

The fan system consists of a heavy base, which stops it falling over. The top of the base contains a pivot bearing on which the motor is mounted, in a way which allows it to rotate in a horizontal plane. The motor shaft is connected to a fan which creates a flow of air when the motor rotates. The fan is covered by a grill which acts as a guard so that the fan cannot come into contact with anything when it is rotating. A gear, also driven by the motor, connects with a reduction gearbox which reduces the rotational speed of the motion from the motor speed to one revolution every 30 seconds. This slow rotating final gear has a pin on its periphery. As it rotates it converts the rotational motion into reciprocating motion by connecting the pin to a link which is connected to the base of the fan.

As for the construction of the fan unit, many of the components are injection moulded from plastics materials. The base has a heavy piece of steel fixed inside it to make sure that the unit is stable, and a bush at the top which allows the motor to be connected to it. The motor itself is contained within a moulded casing, and connected to a metal screen which is a guard to surround the fan. This guard is made from steel wire, powder coated with a protective plastics coating which provides protection from corrosion, as well as making it look aesthetically pleasing. The fan itself is also a plastics moulding. The gearbox unit is also largely made from plastics, a casing with metal axles and plastics gears.

**Block diagram showing transfer or conversion of energy**

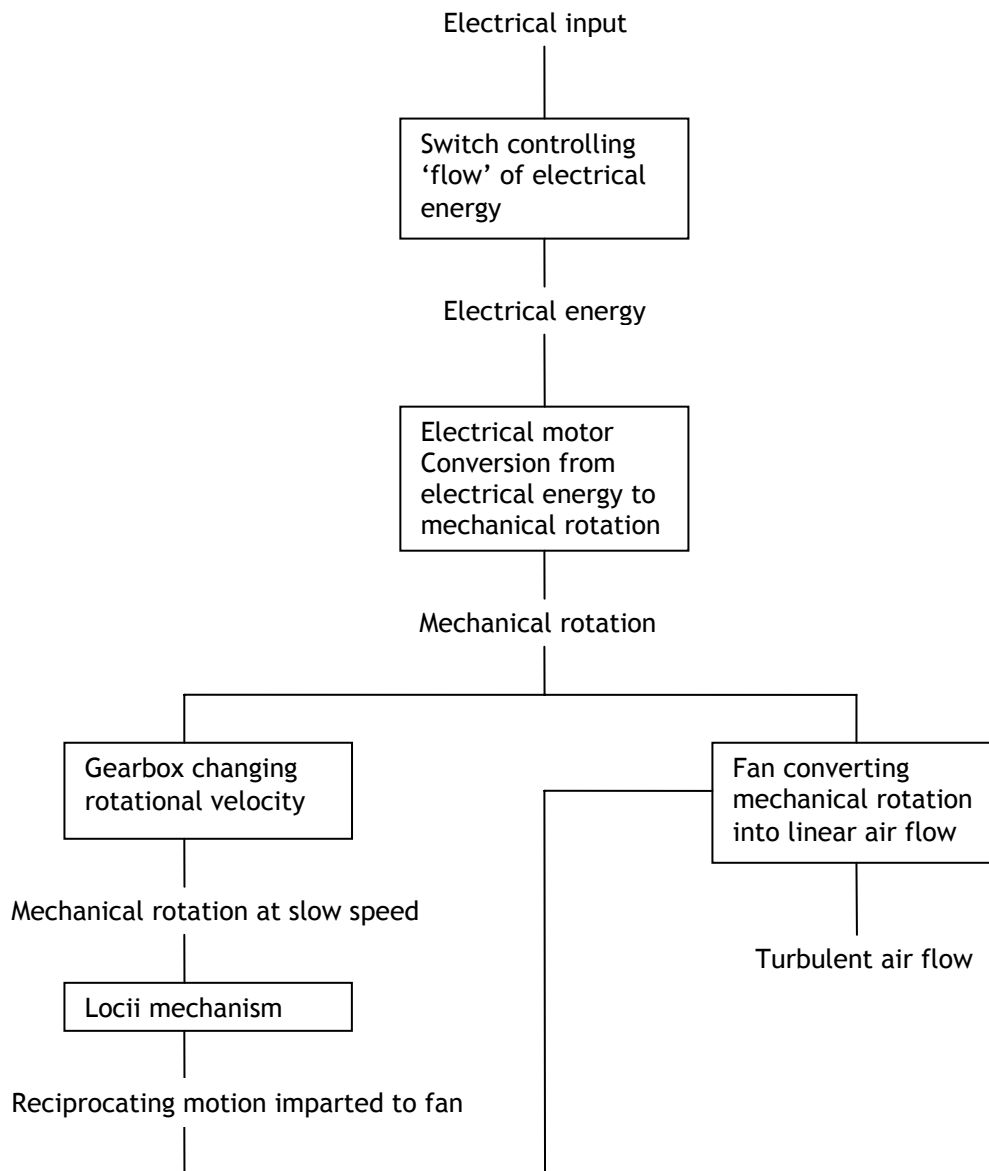

## Overall performance for assessment criteria (b)

*Explain the function of a given electro-mechanical system.*

John has provided a well reasoned explanation of the main function of the fan system with a diagram to show its main functional features. The diagram indicates a feasible method by which an oscillating fan may operate. It may, or may not be how this particular fan operates but it does represent a feasible way in which such a fan could be made to work. John has been credited with full marks for this section.

## Overall performance for assessment criteria (c)

*Investigate the sub-systems and elements that comprise the given electro-mechanical system. Describe using a block diagram, their function, relationships and the transfer or conversion of energy that might occur.*

John has produced a detailed explanation of a feasible way in which the fan system could be made to work. It explains how the fan is driven as well as how the fan is made to oscillate. It is supported by a diagram showing how the fan is organised from a functional point of view. There is also a detailed block diagram, which clearly shows the energy conversions, which take place in the system. John has been credited with the lower end of mark band 3. Inclusion of losses due to friction and heat at relevant points on the block diagram would have generated the full marks available.

## Exemplar student response for assessment criteria (d)

Provide an alternative design solution that fulfils the basic functions of the system.

### Task 3

#### Alternative design solution

A suitable alternative is a portable air conditioning unit. This alternative has the advantage that it actually cools the air in a room and makes it less humid at the same time.

This unit uses a refrigeration system.

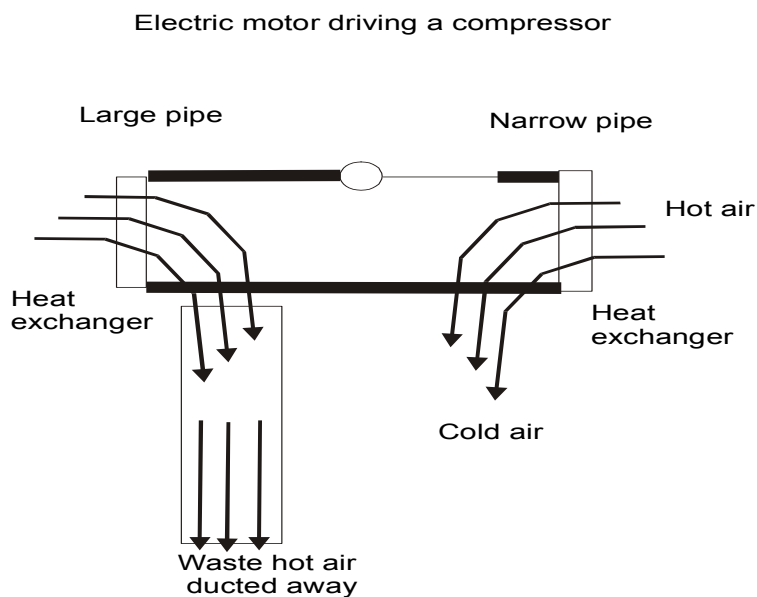

Electrical energy is used to compress a gas (refrigerant) which is heated up as it is compressed. A fan drives air over a heat exchanger (like a car radiator) where the compressed liquefied gas is cooled. This hot air is passed through a flexible tube which is passed through a window or a hole through the wall. The cooled liquid gas is now passed through pipes to another heat exchanger where the liquid is allowed to expand. As it expands it returns to a gas and absorbs heat from the heat exchanger. This heat exchanger has air from the room to be cooled passed over it by a fan, and the cool air is returned to the room. As this air passes over this cooling heat exchanger it is cooled and can no longer hold the same amount of water and if it is humid, then the water will condense on the cold heat exchanger, and then drip into a container where it accumulates. This results in the air returning to the room being both cooled and dried.

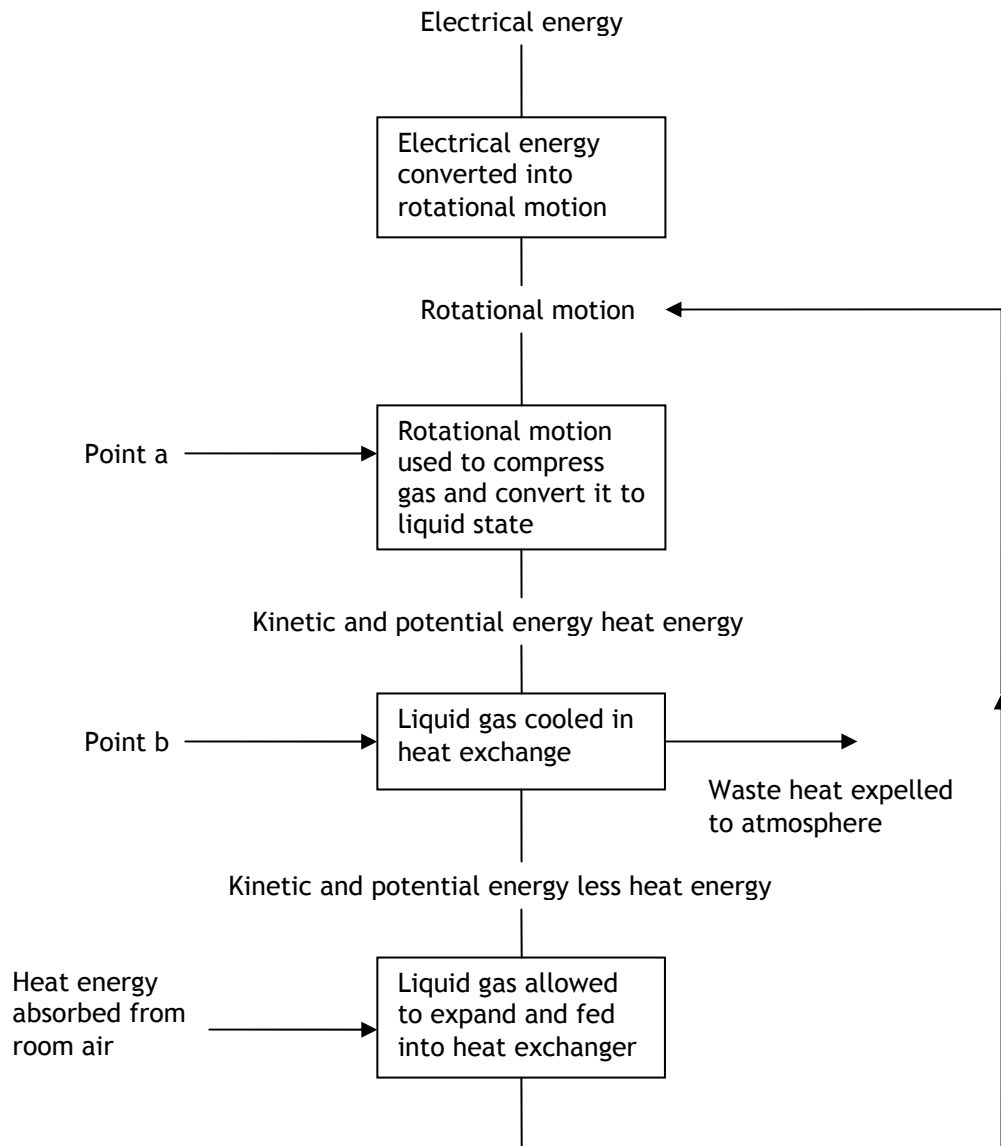

Note: The energy needed to convert a liquid to a gas is absorbed from the room air at point b, and the gas is then recompressed at point a, and the energy given off when the gas is liquefied (by recompressing it) is removed into the atmosphere outside the building.

### Comparison of the fitness for purpose of the two design solutions

The two systems are both able to make a human being feel more comfortable when in a hot room, however, the fan system does not actually cool the air in the room or actually remove heat from the room, it only creates air movement which has the secondary effect of making people feel cooler. On the other hand the air conditioning unit is actually capable of removing heat from the room and expelling it in the form of hot air into the external atmosphere. This will provide superior conditions, by actually making the atmosphere in the room cooler and making the human being feel much more comfortable. The effect of this will be a much greater improvement in comfort.

The air conditioning unit will also reduce the humidity in the room and this will also improve comfort.

The disadvantages of the air conditioning unit include:

- greater energy consumption
- need for duct to outside
- expensive to buy
- greater risk of environmental damage on disposal.

The air conditioning solution will result in less air movement in the room and the fan could provide such movement as to pick paper up from a desk and blow it around.



## Overall performance for assessment criteria (d)

*Provide an alternative design solution that fulfils the basic functions of the system.*

John has provided a detailed description and explanation of a suitable alternative to the oscillating fan, an air conditioning unit. Note that this is a true alternative to the fan system, since the true purpose of the fan is to make occupants of a room feel cooler. Marks would have been awarded for an alternative fan system but such an alternative may make it more difficult to gain maximum marks for this section. The description and explanation is detailed and accurate. It is also fully supported by a diagram showing the main operational features of the system, and a block diagram showing the energy conversions in the system. John has also effectively identified the major advantages and disadvantages of the air conditioning unit compared to the fan system. John has been credited with maximum marks for this section. It is clear that this section is a result of detailed research. In reality, the marks would also have been given for a less-detailed analysis of the air conditioning unit, but this analysis is accurate and complete and certainly gains the maximum marks available.

## Exemplar student response for assessment criteria (e)

Respond to a design specification for a monitoring or control system by producing an appropriate and feasible design solution that takes account of its operational requirements and health and safety considerations.

### Activity 3

Temperature control system covering 20-100°C +- 2 degrees accuracy.

#### Task 1

##### Component selection

The circuit I have used is based upon information in the RS datasheet. This data sheet provides basic circuits and component selection data for designing temperature measuring and controlling circuits. The circuit below, is a modified version of the circuit for measuring temperatures with a thermistor, which I have connected to the circuit for controlling temperature with a thermistor. I also selected a particular thermistor which was suitable for measuring temperatures in the range of 0 to 100°C. The data sheet quotes the thermistor as having an accuracy of 2%, which is within the accuracy required by the design brief. I also selected a relay, which would enable the circuit to control a 2 kilowatt electric heater.

##### Block diagram

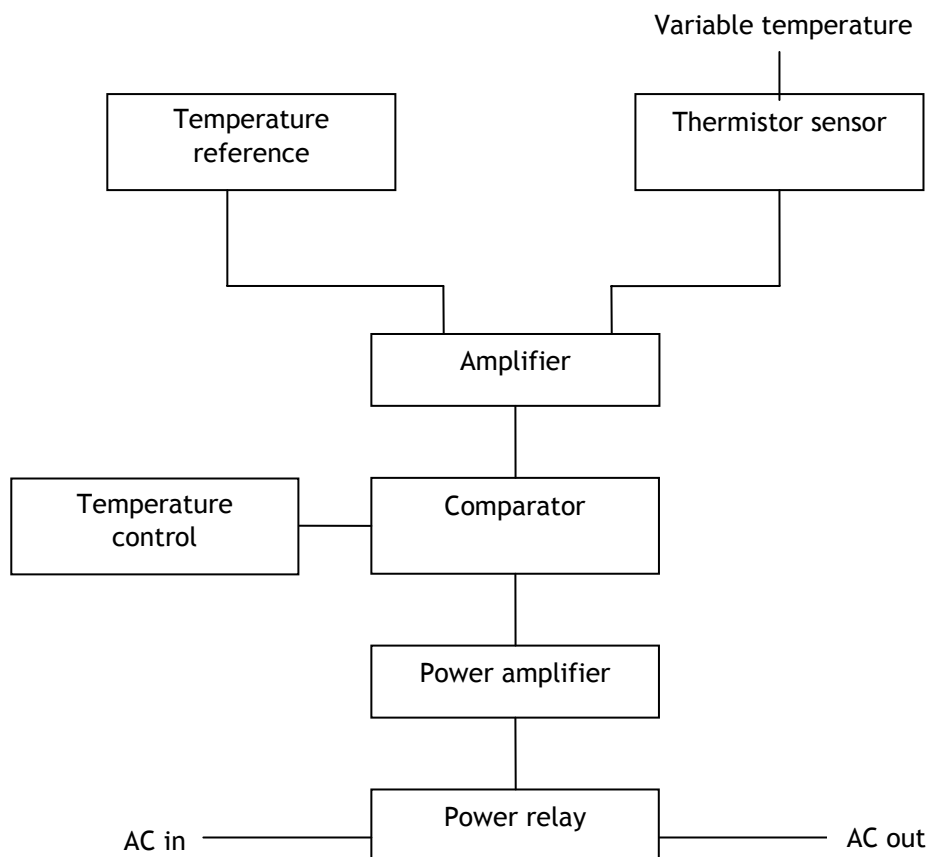

The circuit operates by comparing the resistance of the thermistor with the resistance of a known fixed resistor. The resistance of the fixed resistor and the resistance of the thermistor form a voltage divider circuit which creates a variable voltage on the input of an amplifier. The operational amplifier is connected as a high gain signal amplifier, and it produces a voltage output which depends upon the temperature of the thermistor. This variable voltage is the input to the next stage. A comparator produces an output which depends on the difference between its two inputs. In this case, one input is a temperature dependant voltage, and the other is a voltage set by an external variable resistor which can be calibrated against a temperature scale. The comparator output is a voltage which depends upon the difference between the voltages input to the comparator. This output is fed into a transistor switch. The transistor is held in a non conducting state whenever the actual measured temperature is greater than the required temperature. When the actual temperature is less than the required temperature then the transistor switch is turned on, allowing current to flow through the 12 volt relay. The relay is used to turn ac mains current on and off in an electrical heating circuit. This relay is capable of switching 8 amps, which means that it can control a 2 kilowatt electrical heater.

### **Meeting the design brief**

The circuit has been designed to measure temperatures from 0 to 100 degrees Celsius. This is controlled partly by the selection of an appropriate type of thermistor, and partly by selecting the correct value of resistor which forms a voltage divider with the thermistor. The data sheet states that the thermistor is accurate to 2%. That is that the resistance at a given temperature will be within 2% of the given value. Since the resistance is proportional to temperature then the temperature will be measured to 2% accuracy. At the maximum temperature to be measured, 100 degrees, then the accuracy will be 2 degrees. It does not say if the accuracy value quoted, as 2% means plus or minus 1 degree (ie within 2 degrees) or plus or minus 2 degrees. The worst situation would be if it meant plus or minus 2 degrees, which would be exactly in accordance with the design brief.

### **Health and safety**

The design is reliable because it contains no moving parts and is likely to continue to function correctly once it has been tested for a long time. The circuit is also operated by low voltage, and only the relay, which is mounted at one end of the circuit board, has any mains voltage on it. The circuit is mounted inside a box so that it cannot be touched and is protected by fuses.

## Overall performance for assessment criteria (e)

*Respond to a design specification for a monitoring or control system by producing an appropriate and feasible design solution that takes account of its operational requirements and health and safety considerations.*

John has produced a workable design solution, which is based on published technical data. He has selected a suitable sensor (a thermistor) and selected an appropriate part from a suppliers' catalogue. He has selected a suitable relay to act as the power switching element in the circuit. The arrangement will enable the temperature to be monitored and controlled, although there is no actual indication of the actual temperature as measured. Note that the task did not ask for the temperature to be measured, just monitored and controlled. This circuit seems to do that. John has taken into account health and safety considerations in the design, such as fuses and voltage segregation, and considered those aspects of the production of a prototype which affect health and safety, such as fume extraction when soldering. There is a block diagram, which adds significantly to the demonstration of John's understanding of the circuit and its operation that was required. John has been credited with marks at the top end of mark band 3 for this section.

## Exemplar student response for assessment criteria (f)

*Select suitable materials and components for the design solution taking into account possible production and cost constraints and health and safety considerations.*

### Task 2

The total cost of the materials and components required to make the circuit is under £15.00.

The production constraints are the need to make the circuit in the school workshop, and this means that the circuit can be made by hand, on veroboard, and soldered together manually.

During the manufacture of the prototype circuit it will be necessary to ensure that the circuit board is held securely, to avoid slipping and burns while soldering, and that fume extraction equipment is used to avoid inhaling fumes.

It will also be necessary to wash hands carefully after soldering the components into the board, to avoid ingesting lead from the solder

## Overall performance for assessment criteria (f)

*Select suitable materials and components for the design solution taking into account possible production and cost constraints and health and safety considerations.*

The price quoted for the components is realistic. Note that prices of components stated under examination conditions do not need to be accurate, or totally correct, they just need to be realistic estimates. The justification of the choice of components is accurate and relevant to the block diagram. John has been credited with full marks for this section.

## Unit 6: Applied Design, Planning and Prototyping

### Exemplar student response for assessment criteria (a)

*Appropriate research and the development of a technical specification.*

# **PRODUCTION LINE LABOUR SAVING DEVICE**

## Problem

During a factory visit to a local company called LiteOn, I was talking to their production engineer Eric Davison, who was telling me about his job and how he often had to deal with production problems and related ones that cropped up from time to time. I was very interested in one such problem involving assembly line workers and I thought I would like to try and solve it by designing and making a working prototype that might be adopted by the company. Eric was very supported and invited me to take on the problem, he said he would be happy to help me and to act as my client as the project progressed.

### The Problem

In the LITEON factory, there are manufacturing cells where workers assemble the products. In each cell, workers along a production line place components onto circuit boards. At the end of the production line when all of the components have been inserted, the last worker on the line places the product carrier onto a conveyor belt.

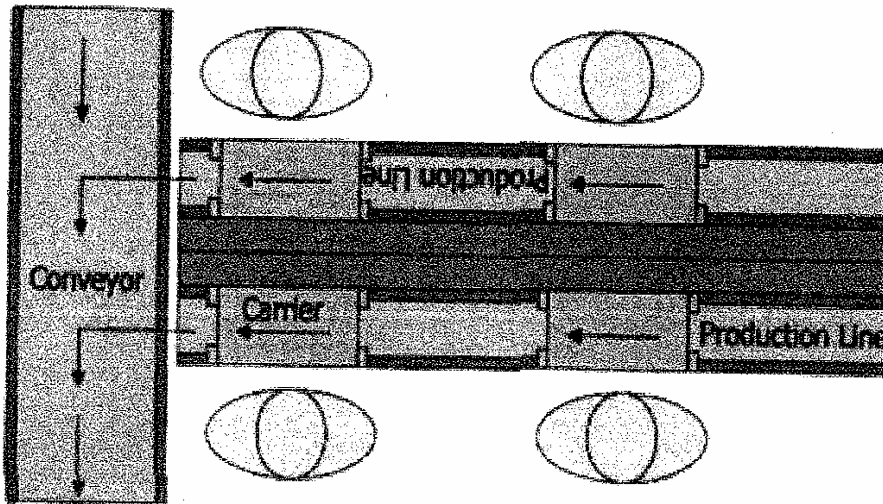

From the conveyor belt, the carrier moves into a soldering machine. This fixes the loose components onto the circuit board.

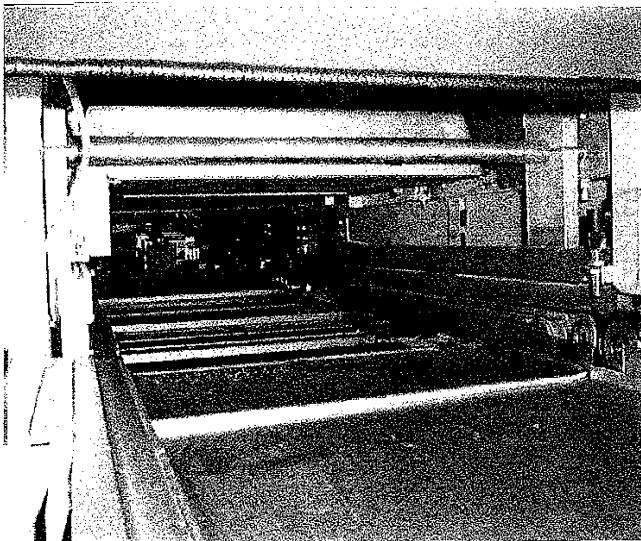

The Wave Solder Machine where the Carrier and Circuit Board pass through



## Lifting and Turning

The last worker on the production line must lift the heavy carrier first upwards, and then twist around to place it on the conveyor belt. Because LITEON has a high rate of production, this worker must perform the awkward manoeuvre once every minute. This can cause Repetitive Strain Injury (RSI)

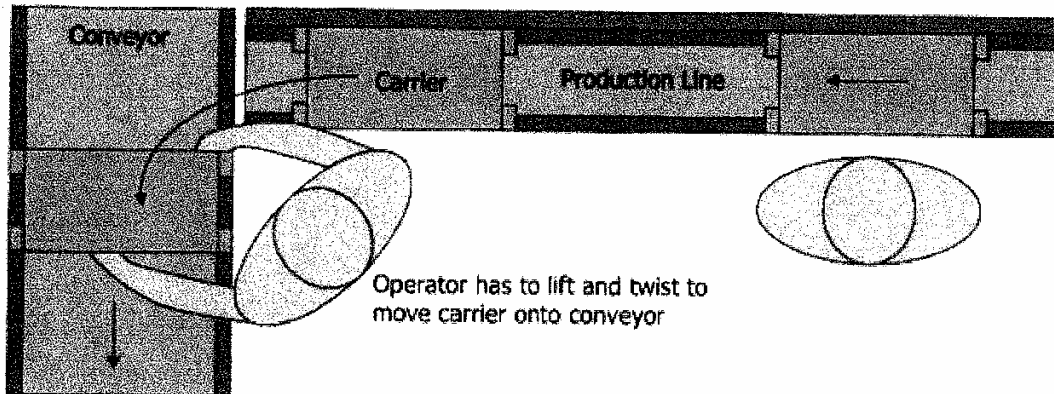

Eric provided me with a general idea of this problem.

### Solution 1 – A Lift for the Carrier

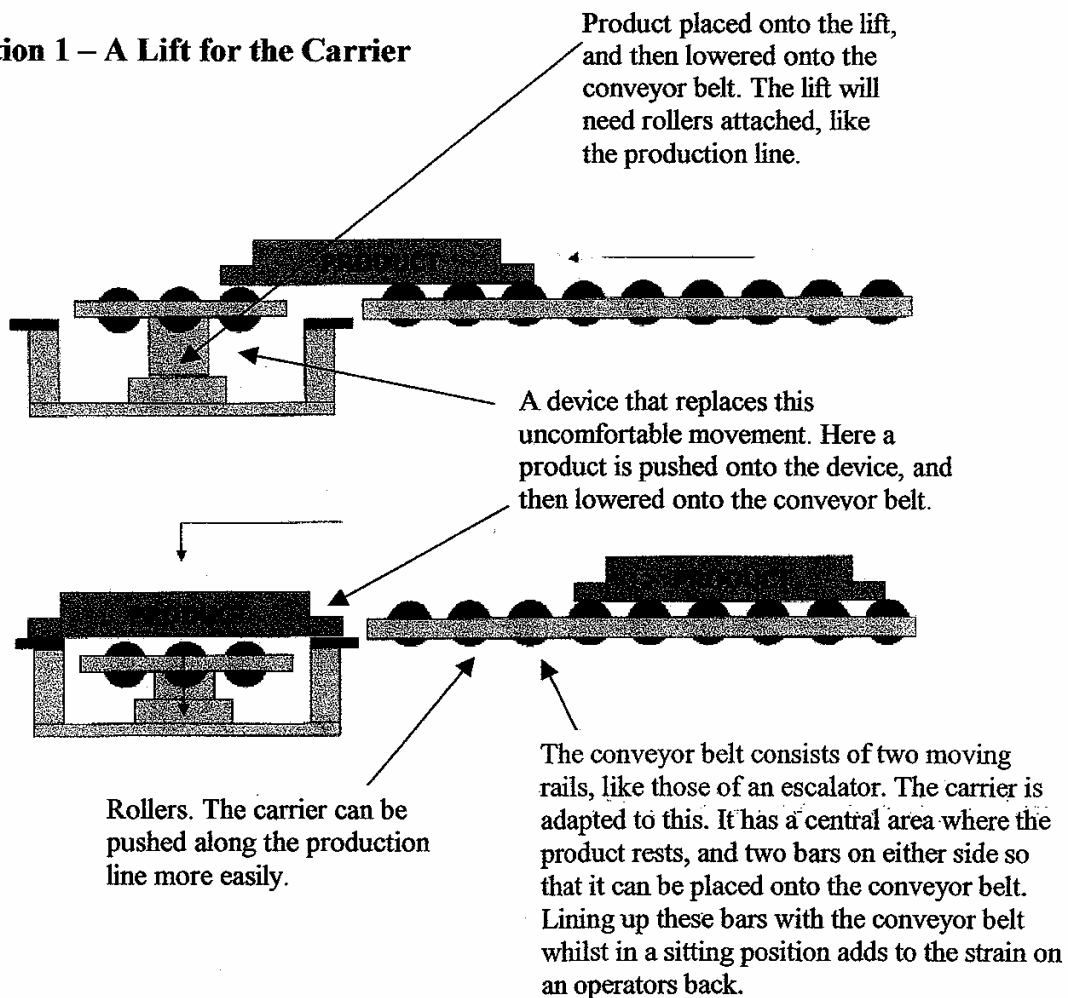

## Problem and Solution 2

The lift should be as automated as possible, so that the worker needs very little training to operate the device.

A system exists on the conveyor belt that uses magnetic sensors to detect when the carrier is nearing the Wave Solder machine. When a carrier passes a certain point, the Solder machine is activated. This saves energy because the Solder must be very hot.

As two production lines operate simultaneously, a lift in the up position may block the path of an oncoming carrier. These sensors can be utilised to either warn the worker so that they can operate the lift, or move it automatically. Only one sensor is needed, as it is only the carrier closest to the Wave Solder Machine that will obstruct the oncoming carrier from the opposite production line.

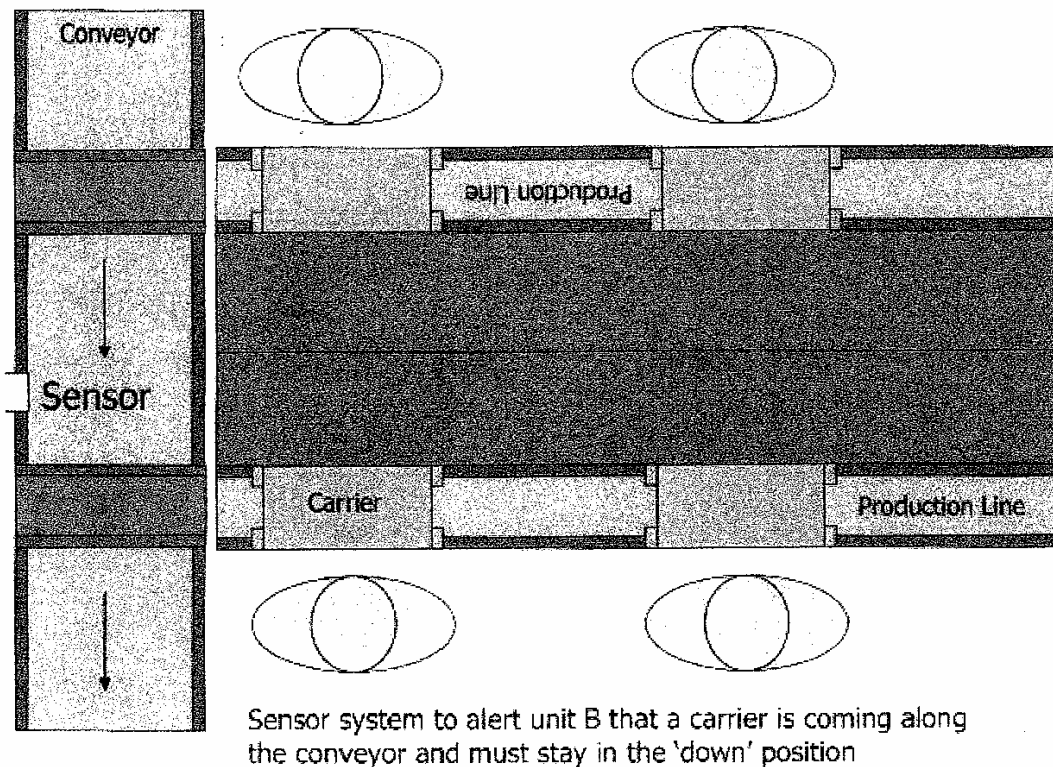

From my initial discussions with my client and the information gathered regarding the problem, I wrote my design brief, which Eric agreed was appropriate.

Project Brief –

***“Design and build a prototype device which will take product carriers off the end of the Manufacturing Cells and load them onto the conveyor system without the need for Production Operators to lift or twist. The device must be adjustable in order to accommodate widths of carriers between 150mm and 300mm”***

## ANALYSIS

In order to focus more closely on what had to be done in my project, I wrote an analysis of the problem as a starting point and as a guide that I could follow to make sure that I covered all necessary areas of research and information gathering

1. What is the function of the design?

The function of the design is to safely transfer carriers containing products, from the production line to the conveyor belt in the manufacturing cell on the LITEON factory floor. This needs to be done to prevent the workers on the production line suffering from RSI. The design also needs to take into account other carriers coming down the production line about every 60 seconds - these must not collide with the platform of the design.

2. Where will the design be used?

The design will be used on the production line at the LITEON factory. It will need to fit between the motorised lines of the conveyor belt. There is a large gap in between that can be utilised. There are also hooks on both the inside and outside of the conveyor system. The device could be fastened to either of these. Alternatively, it could be floor mounted.

3. Will it be portable or fixed?

The design will need to be portable because it may be required in one of the eight different production lines in the cell, and so have to be moved easily. There are only ever two production lines working simultaneously in a manufacture cell.

4. Are there any restrictions on size?

The design must fit in-between the conveyor belts. It also has to be large enough to support the largest and the smallest carriers

5. Does the design have to withstand any forces?

There are no significant forces that the design will have to withstand other than the forces brought on by its use, which will not be large. This is because workers will use it, so it will not be deliberately damaged.

6. What processes will be used to make the product?

The product will be made using metal bending techniques, bolting, and spot welding.

7. Are shapes or sizes unsuitable?

The design must fit between the conveyor belts, and be able to accommodate all sizes of carrier.

8. Will cost be a factor of the designs?

Cost will be a minor factor, quality will not be reduced because of a higher cost, and only unnecessary things will not be included to restrict the cost.

9. Are there any safety factors to take into account in the designs?

Pneumatic systems can be dangerous, so there may need to be some sort of guard to enclose the design and prevent mishaps. The voltage that will be drawn from the main factory line will also be very large so safeguards must be introduced.

10. Which mechanisms and power sources will be needed in the designs?

The design will need a pneumatic source and a piston to power the vertical motion of the lift. It will also need an electrical power supply of 24 volts D.C to power the circuit, this may need to be transformed from the power supply in the LITEON factory.

11. Can I use any ready-made articles in the design?

Some ready made articles can be used. A transformer may be used.

12. Will it help to build a model before the final production?

It would help to build a model in order to show our ideas, and to also communicate them to LITEON. This is essential for development of ideas.

13. Will the finished product need any maintenance?

The finished product should require as little maintenance as possible.

14. Which materials are uniquely suited or unsuited to the design?

The design requires the strongest materials possible because of its use. So metals are the most suitable materials. The product will also have to be moved from place to place so it should be as light as possible.

## INITIAL DISCUSSION WITH CLIENT

- **Method by which the platform will raise and lower:**

There are four different practical ways to raise and lower the platform. A pneumatic or hydraulic piston would raise and lower the platform using air or liquid under pressure. A solenoid with an iron core would raise or lower the platform when a current was passed through, or a motor would raise or lower the platform electronically/electrically.

### 1) Pneumatics:

A piston would be fastened to the base of the platform powered by compressed air. The piston would have to be bolted in a specific position to ensure that the platform could raise and lower above and below the production line, and not make contact with the conveyor belt mountings. To achieve this a piston with a stroke length between 50 and 90 mm would be needed.

A circuit would operate a five-port valve, which would control the airflow through the piston, and give it a positive or negative movement. A five-port valve is required because a double acting cylinder, which allows movement in two directions, is needed. By using uni-directional flow-restrictors, the speed of the piston movement can be controlled. The flow-restrictors can be set so that the platform will lower slowly, but rise more quickly to protect the components. Pneumatics would be a cheap and easy method to raise and lower the platform. There is already a compressed air supply running at a sufficient pressure in the factory to run the piston. The main disadvantage of pneumatics is that there are dangers if a pressurised pipe breaks free, as it can cause serious damage by puncturing the skin as an embolism may result.

### 2) Hydraulics:

Hydraulics uses compressed liquid as the power source instead of compressed air. A major disadvantage in hydraulics is the installation cost because the LITEON factory does not have a hydraulics system. This method was ruled out.

### 3) Motorised:

An electric motor would raise and lower the platform. There is a power supply in each cell in the LITEON factory. An idea for this system would use the rotational motion of the motor to turn two threaded lead screws that are mounted into the frame. Gear wheels on the motor rotate the lead screws simultaneously. The lead screws would then rotate inside a threaded sleeve, moving it up and down. This is another cheap option, which presents little danger to the workers. It offers a very smooth action and can be controlled using electronic circuitry. The circuitry however, may become more complicated as it would need to set a mark-space ratio to give the speed of the rotation. An advantage of setting the speed using circuitry and a motor is that the platform could move more slowly at the end of the action. For example, controlled by using a program. The disadvantage of this idea, however, is that a large amount of rotational motion is needed to raise the platform a small distance, so the movement would be slow.

### 4) Solenoids:

The core of the solenoid would be attached to the base of the platform. By default it would be in the up position due to a spring at its base. The electromagnet would draw the core and the platform

downwards when current flowed. The running of this mechanism would be expensive due to the constant electric current. The movement produced would be fast and jerky and the components on the carrier may be shaken out of their mountings on the circuit board. The solenoid is also likely to wear over time. For example the spring could stretch and change the normal level of the platform therefore the carriers would not be able to slide directly on from the production line.

At this point I consulted with my client Eric, who advised me on what power sources were available in the factory and what systems he would prefer to use if the final prototype was to be used by the company.

### **Choice of Method**

Pneumatics has been chosen because it is the most effective, cheapest and easiest method to raise and lower the platform whilst ensuring the safety of the workers. It will provide a smooth motion that could easily be controlled using flow-restrictors. The piston will raise and lower the platform in a shorter time than a motorised system. This way, when a new carrier is ready to be placed on to the platform there will be no delay in the production because the platform can be made to rise quickly and the worker does not need to wait.

- **Adjustment of platform to hold different sized carriers:**

The platform must be able to accommodate each size of carrier. The dimensions of carriers range from 250 mm to 500 mm in width.

Using two metal tubes to give a telescopic effect, either side of these tubes would be spot welded onto a rail, with one of the rails being fixed permanently. The other rail would extend to accommodate the larger carriers. When the rail is extended to the required length, a screw that passes through the outer tubing or a 'quick release' system, similar to those used on modern bikes will be used to tighten the tubes so that they will not move. The tubing could be calibrated so that the worker at the factory would be able to tell how far the platform was currently extended, and how far it would need to be extended for each different width of carrier. On each rail sets of wheels will move the carrier along smoothly as on the production line. At the end of the rails there would need to be a stopper to prevent the carrier from falling off the platform. This would be a flexible and easy system, although it would mean the adjustable piston would have to be attached to one of the rails, and be able to adjust with the telescopic rods.

- **Integrating the device onto the conveyor system, and mobility issues:**

The device needs to fasten to the conveyor system and be portable as it may occasionally need to be moved. It must not, therefore, be too bulky so that it can be portable. The device could be mounted on the conveyor belt, or mounted on the floor between them.

### **1) Hung from the conveyor mountings:**

The frame would be bent at the top so that it could hook into the groove on the conveyor belt mounting and hang down underneath the conveyor system. The frame would be secured in place by inserting a bolt through the frame so that it made contact with the conveyor belt mounting.

### **Adjusting the Size:**

With the frame hanging below the conveyor belt, the adjusting piston would rest on a bar, connected to rails running along the inside of the frame. When the platform was adjusted, the piston would move along the rail and also adjust in size.

- **Electronics/Sensing:**

The electronics will co-ordinate the mechanical components. The platform must be below the conveyor system when there is another carrier nearby on the conveyor belt. It must also rise to collect carriers from the production line. Magnetic sensors are used to detect the carriers in the factory, to activate the wave solder machine. These can be used to detect the carriers and activate the circuit. Using logic gates, or using a programmable microprocessor, amplifiers and outputs are two possible methods of controlling the lift using circuitry.

### **1) User controlled:**

No sensors would be used to detect oncoming carriers and the production line worker would be fully responsible for lowering the lift when carriers approached. They would need to lower the lift when a carrier approached to avoid a collision, and raise the lift once the carrier had passed. The circuitry for this method would be simple. This is a cheap and simple method causes problems because the worker would already have a task to do, and would not watch the conveyor system constantly. There are likely to be a number of accidents involving an oncoming carrier and a raised lift.

In this circuit, the input switches would be PTM (push to make) switches which cut off the supply to the solenoid valves unless they are pressed - one button corresponding to each valve. There would also however need to be a NAND gate that would prevent both of the valves from being activated.

### **Chosen Idea**

Magnetic Sensors will detect when another carrier is moving down the conveyor system and lower the carrier. Magnetic Sensors will also detect when the carrier has passed over the lift, and raise it. When there is a carrier ready to be lowered onto the conveyor the worker at the end of the production line presses a button on a control box. They can then raise the platform once the carrier has moved.

To process the inputs, a PIC (peripheral interface controller) will be used and programmed to provide the logic for the circuit. The outputs from this will then be amplified using standard NpN transistors and the solenoid valves will be run from a higher voltage, drawn across.

To ensure that the carrier does not roll off the end of the platform, there will be a stopper.

I discussed the problems of using pneumatics equipment my client the production engineer and these are the results of our discussions:

Because a pneumatic system would be much cheaper, cleaner and easier to install and maintain, I decided to use it as the power source for the up and down motion of the lift.

The alternative, hydraulics, is more expensive because it needs pumping equipment and much more maintenance. LITEON is already equipped with airlines under each production cell, and so integration of the device would be even cheaper because the compressed air supply is already in position.

### **Type of Air Cylinder**

Because the air cylinder needed to have both an upward and downward stroke, I chose a double acting cylinder. This means that air can be added at either end of the cylinder, and the direction of the stroke can be controlled.

Stroke length was an important factor to consider, because this would be the distance travelled by the platform. It was important that the platform moved from the level of the production line to below the conveyor belts, so that the carriers were deposited. This factor would also affect the dimensions of the actual device, since a greater stroke length would mean that the device needed to hang lower so that the platform, when fully raised, was at the same level as the production line. An air cylinder with stroke length 80mm was used.

### **Problem with Life Expectancy and Jerky Movement of Air Cylinder**

In my research concerning Air Cylinders, I discovered that the piston strikes the end of the cylinder with considerable force after being raised or lowered. This severely reduces the life expectancy of the piston, because with each outward or inward stroke, the mechanism within the air cylinder is weakened. I decided to use a cylinder with a cushioned mechanism, so that when it strikes the end of the cylinder the impact is absorbed and the life expectancy is increased.

Because the carrier on the platform contains assembled circuit boards, with components placed in position but not soldered in, the components are loose. The pneumatic system causes a build up of air followed by a jerking movement, then a drop in air pressure, another build up of pressure and another jerking movement. These loose components were likely to be shaken out of their position on the board when the platform was moved, because of the jerking movement. I needed to find a way to make the movement of the air cylinder as smooth as possible, so that the components were not shaken out of their positions on the board. To solve this problem, I decided to use Unidirectional Flow-Restrictors at the exhaust of air. This way, the air-flow would be constant at the end of the cylinder where the piston needed to be pushed, but restricted at the area where the air was exiting the cylinder. This would eliminate the build up of pressure followed by a push, which caused the jerky movement.

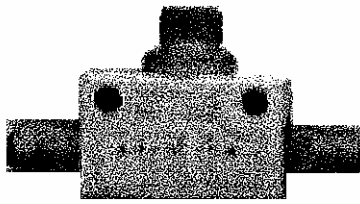

Unidirectional Flow-Restrictors which, when placed at the air exhaust, eliminate the jerking movement of the platform.

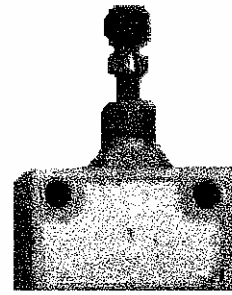

A Five-Port valve is needed to control the flow of air, and because we have chosen to add an electronic control method, as opposed to a manual lever control, solenoid valves must be added so that the circuit can interface with the five-port valve.

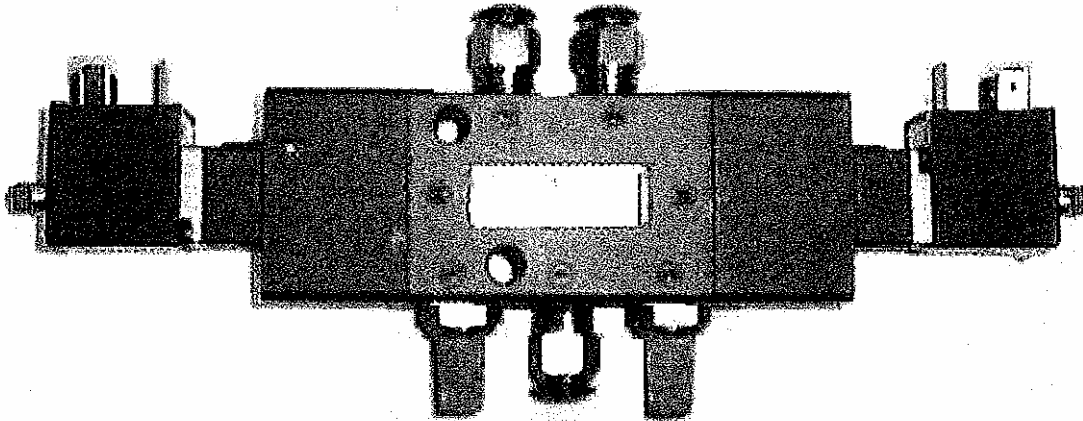

A solenoid operated Five-Port valve. Together with the circuitry, this will control the air cylinder to either raise or lower the platform.



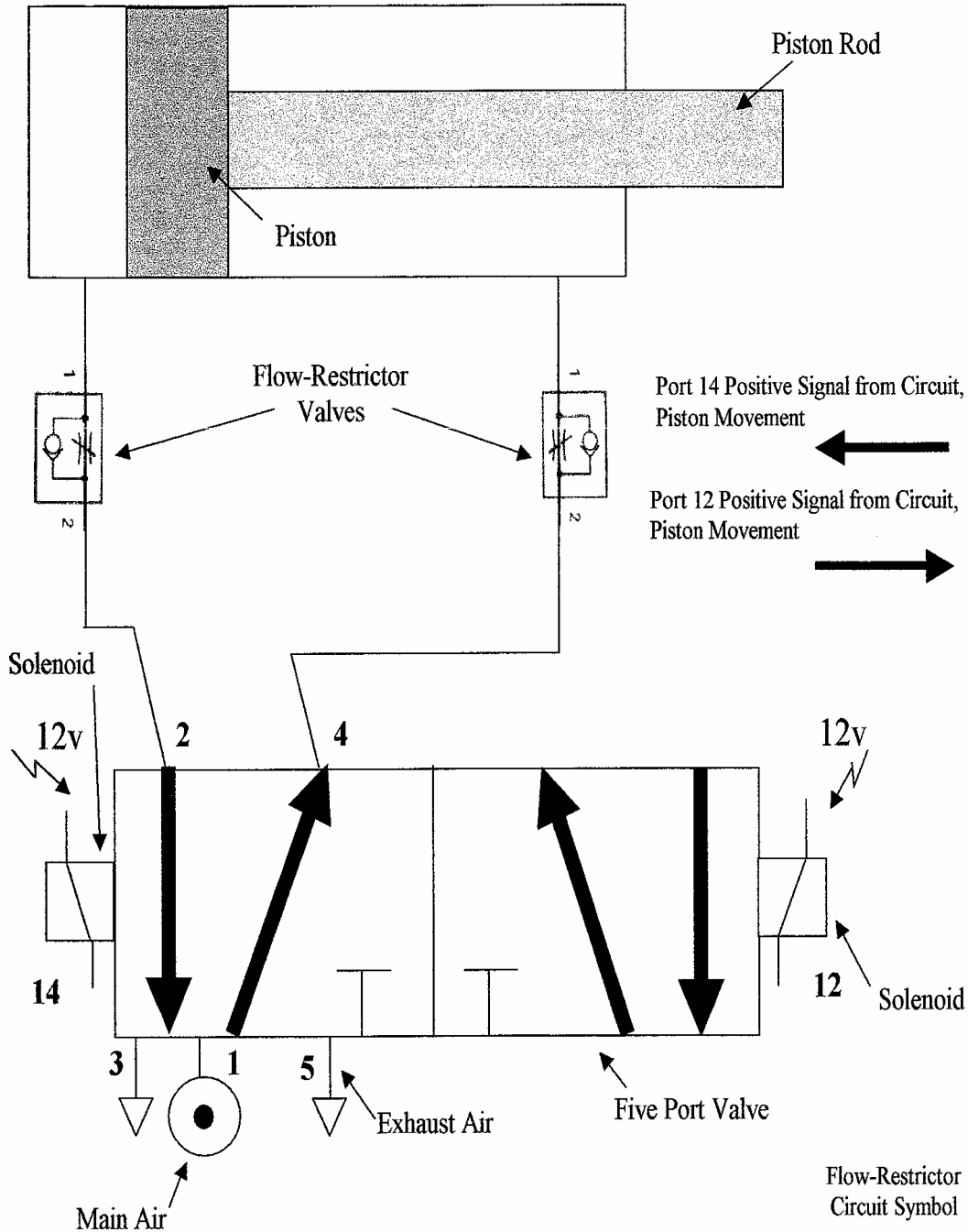

The Flow-Restrictor in Detail

Air can flow either way through a flow-restrictor. If air enters the device at port 1 and leaves at port 2 its rate of flow can be increased or decreased by turning the adjusting screw. If air flows the other way, entering at port 2 and leaving at port 1 the adjusting screw has no effect and the air flows freely. The air pressure overcomes a spring holding a non-return valve closed. The non-return valve is lifted off its seating. Air can now bypass the adjustable needle and flow freely through the device.

This way, only the exhaust air leaves through port two and the speed of the piston can be controlled. This is achieved in both directions of piston movement by placing flow restrictors at ports two and four on the five port valve.

## PNEUMATICS RESEARCH

### Calculations Involving Air Pressure

The air pressure at the LITEON factory is 100psi, which translates to 689500Pa (N/m<sup>2</sup>). The bore of the piston is 80mm (0.08m) which gives an area of 0.02 m<sup>2</sup>. The approximate weight to be lifted is a maximum weight of 3kg. The stroke length of the piston is 80mm (0.08m).

Force = Pressure x Area  
Force on piston  $\approx$  14000N

Force = Mass x Acceleration  
Acceleration = 4700ms<sup>-2</sup>

$$V^2 = U^2 + 2aS$$

Final Velocity with no airflow restriction or cushioning = 27ms<sup>-1</sup>

This is very fast, and the piston would be damaged, and the components shaken from the circuit.

A much more reasonable final velocity would be 0.2ms<sup>-1</sup>. The force needed to give this velocity would be:

$$\begin{aligned} \text{acceleration} &= \frac{V^2}{2S} \\ &= 0.25\text{ms}^{-2} \end{aligned}$$

Force = Mass x Acceleration

Force = 0.75N (above the force needed to cancel out gravity, which is 29.4N)

Force Needed = 30.15N

$$\text{Pressure} = \frac{\text{Force}}{\text{Area}}$$

Pressure = 1500Pa

The uni-directional flow restrictors would restrict the main air pressure down to a suitable pressure to power the piston with the required amount of force.

# PNEUMATICS RESEARCH

## Double-Acting Cylinder

A double-acting cylinder is similar in every way to a single-acting cylinder, except that it uses air pressure to return it to the initial position rather than a spring. This means that there is an air port at either end of the cylinder that are used alternatively for exhaust air or for pressurised air, and that the piston is controlled pneumatically in both directions which gives it more flexibility and allows it to be used in different situations. Cushioned cylinders are also available that cushion the impact of the ram at either end of the piston. These pistons have pockets where air is trapped as the piston moves. The more these pockets of air are compressed, the greater the restrictive force placed on the piston so the ram will slow down less rapidly than when it collides with the end of the piston. There are small, adjustable holes in the side of these pistons that allow the speed of the exhaust air from the pockets to be controlled.

## Single-Acting Cylinder

These are almost identical to double-acting cylinders other than that they have a spring that returns them to the rest position after extension. This however means that the piston will not return to rest if there is a powerful load on the end of it. This makes this variety of piston unsuited for certain environments. This piston also has two air ports, although one is always used for exhaust air and the other always as an input. The control of single-acting pistons is also simpler than for double acting cylinders.

## Solenoid Valves

An electrical circuit may be used to control a pneumatic circuit. This can be done using an electro-pneumatic valve such as a solenoid valve (Either a 3-port valve or a 5-port valve). A solenoid is a coil of wire that creates a magnetic field when a current is passed through it. This can be used to operate a valve by attractive an iron armature. Solenoid valves are extremely useful because they allow for the remote operation of pistons. A 3-port valve is just like a switch for the air pressure. When the current is triggered the air pressure flows through it, latched, until the next pulse of current to the solenoid. A 5-port valve is effectively two 3-port valves; it switches the airflow between two outputs, so that there is always an air output from one of them. This can be used to easily operate a double-acting cylinder. Although this can also be done with two 3-port valves there is a chance that both can be switched on at once, which causes the piston to move only very slowly in the positive direction, this is avoided by using a 5-port valve.

## Pressure Operated 5-port valves

These are operated by air rather than a mechanical mechanism such as a lever, push button or a solenoid. A spool, with 4 sealant 'O' rings around the air passages through it is moved to one of two possible positions by the air pressure coming into ports 12 or 34 at either end of it, allowing a flow of air through either ports 1 and 2 or 3 and 4. These are useful in situations where the environment is not suited to electrical circuits, for example in high temperatures, and they were used extensively in the past before solenoid valves were widely used.

## Calculating The Force Exerted By A Pneumatic Piston

The force that a piston exerts on an object can be calculated from the air pressure of the supply and the area of the piston ram. This is because  $\text{Force} = \text{Pressure} \times \text{Area}$ . The area of the piston ram can be calculated from the diameter of the piston with the equation  $\pi r^2$ , where  $\pi = 3.142\dots$  and  $r =$  the radius of the ram (all piston rams are spherical). The air pressure will be found on the compressor for the system.

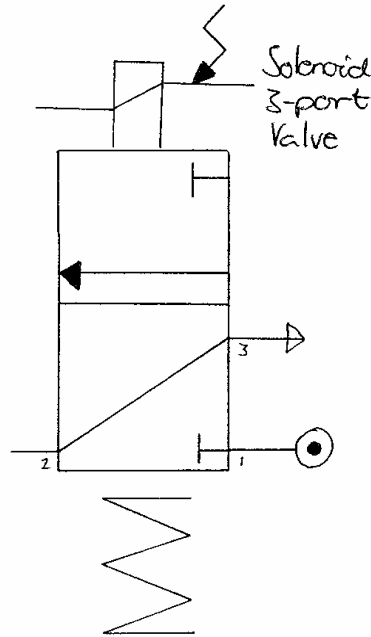

This is a 3-port valve that is triggered by a current. A high current is required to run the solenoid in this.

This is a 3-port amplifier valve. It can register very small pressures of down to 5 mbars.

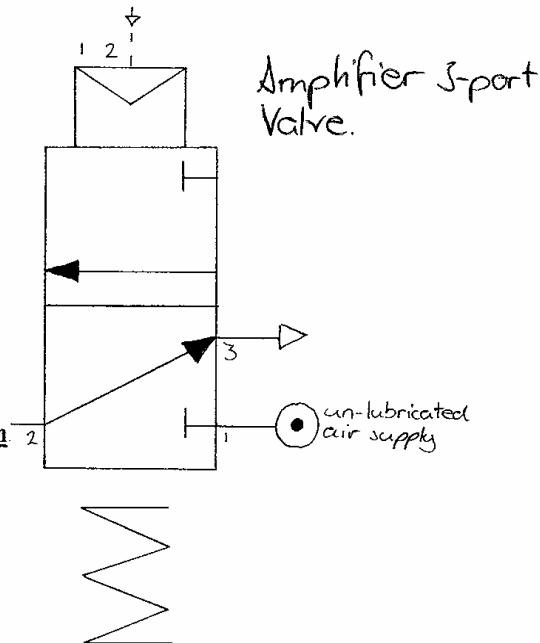

# PNEUMATICS RESEARCH

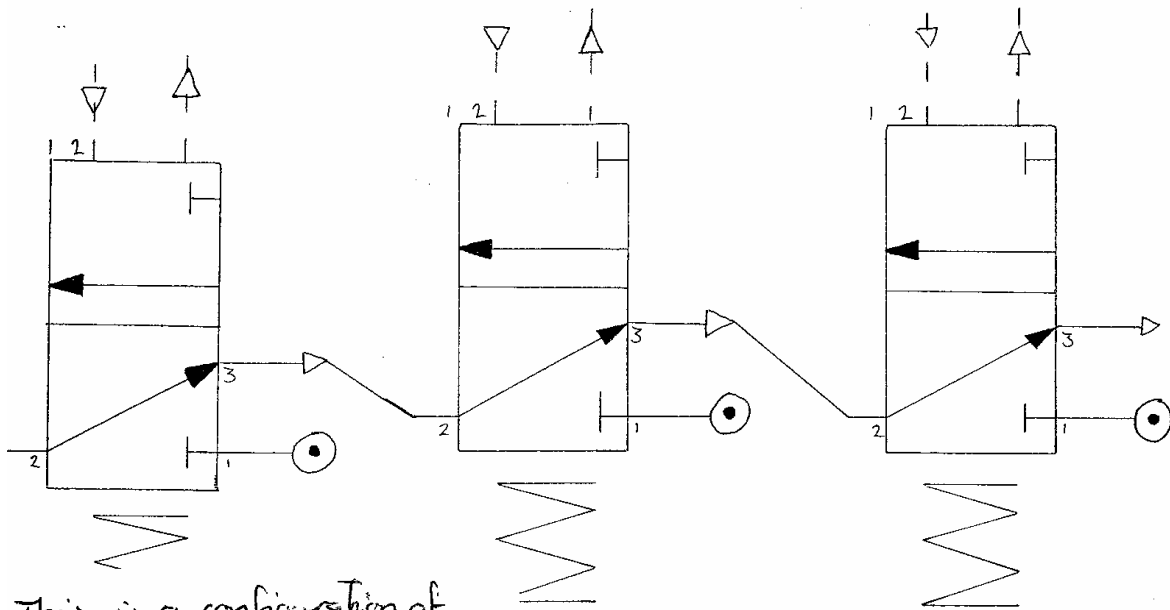

This is a configuration of 3-port valves that gives an 'OR' logic function. A positive pressure from one of the secondary valves flows through the exhaust ports to the main line where the primary outputs.

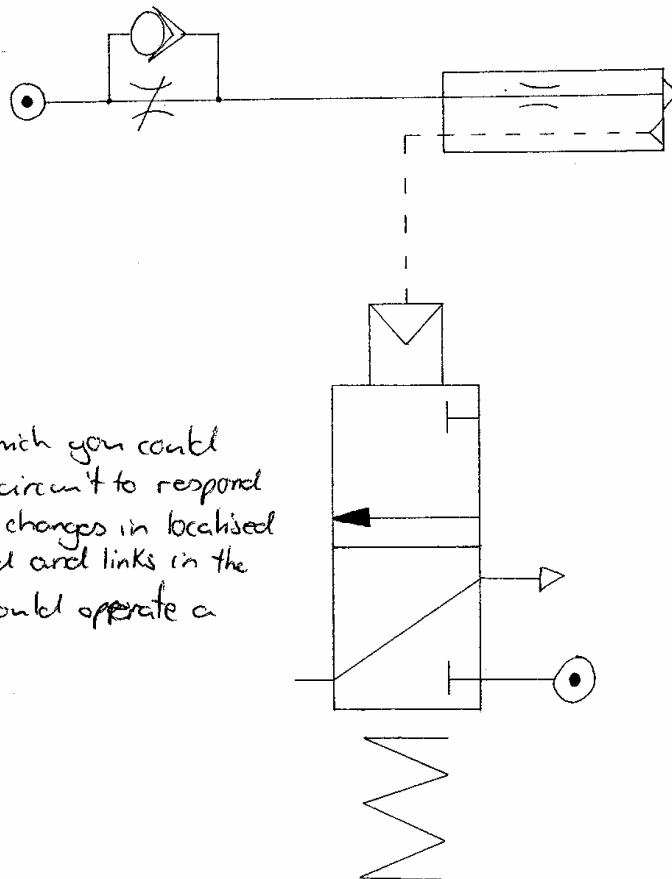

This is a way in which you could construct a pneumatic circuit to respond to movement. The tiny changes in localised pressures is amplified and links in the full supply, which could operate a piston for example.

## **ELECTRONICS RESEARCH**

Having researched into pneumatics aspects of my problem, the sensing and electronic parts were less of a problem, as I was more familiar with these technologies.

I decided to find out about programmable devices as logic would be likely to be involved and these devices are ideal in replacing complex logic circuitry.

I also needed to research into power supplies and how to utilise the factory's electrical supply cheaply and effectively in my low power control system.

### **Microprocessors**

These are integrated circuits containing memory, which can store a program. The program that is written determines the function of the inputs and outputs (which can be either analogue or digital). Complicated logic and delays can be incorporated into the program. This makes a huge saving on PCB. The program for the microprocessor can be written on a piece of PC software that can then be downloaded into the appropriate chip through a piece on hardware.

One microprocessor widely available to me at school is the PIC (Peripheral Interface Controller). There are a number of different forms of this chip though.

8 pin – 12F641 2 in. 4 out.

8 pin – 12F675 2 in. 2 out. 2 analogue in.

18 pin – 16F84 5 in. 8 out.

18 pin – 16F716 3 in. 8 out. 2 analogue in.

28 pin – 16F872 8 in. 8 out. 4 analogue in.

In some of these chips a resonator needs to be added to set the lock frequency of the processor. An output from a PIC processor must be amplified to run anything more demanding than a LED. They run on 5v D.C.

There are various pieces of software that can be used to create a program for the chips. PIC-Logicator uses a visually based programming technique to create the programs. Where as the Basic Stamp software Basic Stamp uses a more powerful basic programming language, but is harder to learn and use.

# ELECTRONICS RESEARCH

## Magnetic Switches: Hall Effect

### What is a Hall Effect magnetic switch?

Definition: A sensor whose output changes based on changes in magnetic flux. Typically used for RPM, position or current measurement.

### When does the Hall Effect occur?

The Hall Effect occurs when the charge carriers moving through a material experience a deflection because of an applied magnetic field. This deflection results in a measurable potential difference across the side of the material which is transverse to the magnetic field and the current direction.

### The sensor itself

Hall sensors are available in a wide variety of shapes and sizes adapted for many different applications. The two basic types are transverse and axial.

### Transverse

The transverse type is useful where the field must be measured in thin gaps and for multiplier applications.

### Axial

The axial type must be used where the field is parallel to the axis of a hole, such as in traveling wave tubes or solenoids.

Some of the advantages of using magnetic sensors are:

- Cost Effective.
- Reliable.
- Easy to implement.

Integrated circuits which use Hall Effect sensors are beneficial because they increase the stability, accuracy, and flexibility.

Other types of sensors which are available include:

- Latched switching sensors.
- Bipolar switching sensors.
- Unipolar switching sensors.

Another alternative type of switch that we could have used instead was a Reed switch. The reed switch can be considered the simplest magnetic sensor to produce a usable output for industrial control. It consists of a pair of flexible, sealed in a gas filled container, often glass.

Reed switches are maintenance free and highly immune to dirt and contamination. The contacts are covered with Rhodium to ensure a longer life. You can also get latching reed switches and mercury-wetted reed switches.

# ELECTRONICS RESEARCH

## Transforming An A.C Supply To D.C

If I use a high current or voltage device I will need to use a separate power supply. This can be achieved through a high power battery, but a permanent, transformed mains supply is much more effective. It is quite a lengthy and complicated process to completely transform a supply however.

The stages to the process are:

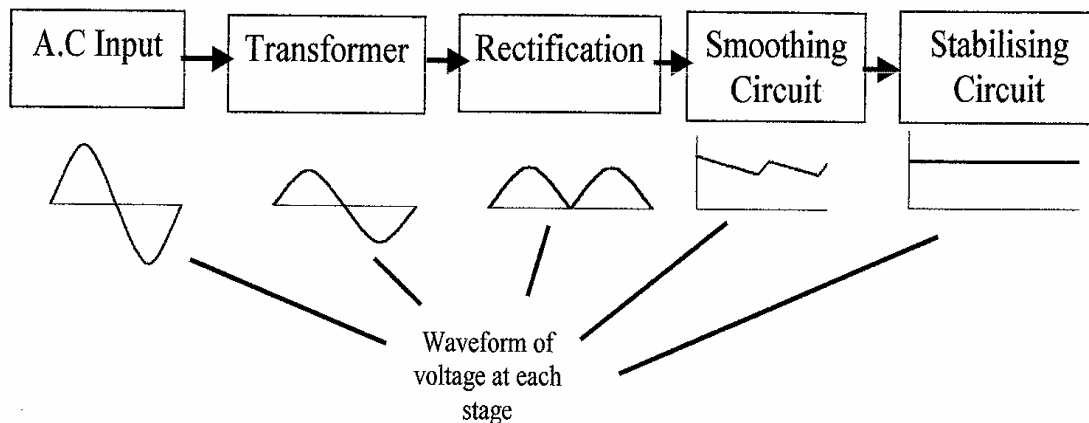

Using these stages a final D.C voltage is produced. The value of the final voltage will be equal to the *rms* (rather than the peak value) value of the A.C voltage after it has been transformed.

## Darlington Driver IC

I will be using transistors to amplify any outputs. To do this more efficiently a Darling Driver IC could be used. This is an 18 pin DIL (dual in line) integrated circuit. It will be easier and save a great deal of space if multiple transistors are needed. The chip contains 8 darling ton pairs which each require 1.2 volts across the base (input pin) to trigger. Each has a maximum output current of 0.5 Amps. This can be increased to 1 Amp if they are paired up – a single input leading to two pins. Each also has a diode to prevent back-EMF. So the chip is suitable for use with electromagnetic devices such as motors.

# SPECIFICATION

## Function

The device must remove product carriers from the ends of the Manufacturing Cells and load them onto the conveyor system without the need for production operators to lift or twist during the transfer process.

## User Requirements

The device should be capable of being used easily, quickly and safely by operatives, so that it has advantages over the manual system.

There should be no maintenance or adjustments required by operatives, so that they can focus on the production line.

The device should remove the need for any physical lifting of product carriers by operatives, so that there is no risk of RSI

## Performance Requirements

The device should :

- Fit safely between conveyor belts and remain stable, so that pre-assembled components are not disturbed.
- Rise to the level of the production line and fall below the conveyor belt so that it does not impede other carriers when at rest.
- Avoid oncoming carriers already in place on the conveyor lines, so that disruption of flow is avoided.
- Have a smooth action that is speed controllable, so that optimum efficiency can be achieved.
- Stably transport the carriers without wobble, so that loose components are not lost or disturbed.
- Be capable of being moved between production lines easily, so that maximum flexibility is gained from the system.
- Be able to be controlled simultaneously by two production lines, so that there is no delay of carriers being fed to the conveyor.
- Be adjustable for width between 150mm and 300mm, so that it can accept all widths of carriers in use.
- Be easily maintained, so that it does not interfere with the effective progress of production.
- Run from the power supply that is available on-site, so that there is no expense in installing power sources.

## Materials and scale of production

The device should be manufactured from appropriate materials and existing parts where possible, so that it is robust, tough and reasonably cheap and quick to produce. A small batch of devices will be produced, so the design of component parts should be as simple and easy to produce.

## Costs

The production costs of the prototype must be kept as low as possible without compromising quality and safety and must be less than if produced commercially.

## Regulations

The design and manufacture of the device must conform to appropriate B.S. and I.S.O. regulations.



## Overall performance for assessment criteria (a)

### *Appropriate research and the development of a technical specification.*

David has identified and selected a realistic problem to work on that is based on a true commercial need of a manufacturing company and which, if successful, may be adopted as a working device by the company. An informative outline description of the problem and information gathered through technical discussions with his client is used to clarify and contextualise the problem and to offer some guidance on the availability and limitations of resources within the company. A clear and succinct project brief has been written in consultation with the client that is a statement of intent focusing on the identified problem and need, without pre-empting a final solution. Analysis of the problem has been used as an organisational tool to give direction and relevance to the areas that need to be concentrated on when gathering information. Analysis statements are closely related to the identified problem and underpin the research activities by questioning what knowledge and understanding will be useful when proceeding to the next stage in the project. Research is closely focused on the problem and is guided by the analysis and as a result only relevant and useful information is gathered. As there are no similar products commercially available to use in 'product analysis' and no large target market has been established, David has used an interview with the client as 'market research', to determine user preferences, where the user is the manufacturing company. Relevant scientific and mathematical data has been used in 'pneumatics research' to prove that the available equipment within the company is appropriate to the needs of the project.

A strong specification which is well organised under logical sub-headings, containing relevant points based on previously gathered information, has been produced. Each statement is justified by having more than one piece of linked information to say why the first statement was made. Most statements of specification contain measurable points that can be used usefully to evaluate against initial ideas, development and final outcome. None of the specification points are superficial or general.

David has selected relevant and detailed technical information from a range of appropriate sources, including detailed analysis of the problem, market research (client based), component and systems research and has used scientific and mathematical data appropriately. The written specification is technically detailed and reflects the research carried out previously. All statements are relevant and justified by further linked information and most points can be measured and evaluated against the final prototype.

The evidence presented matches the requirements of the high category in mark band 3.

## Exemplar student response for assessment criteria (b)

Generation of at least three alternative design ideas and their development into a final design solution using appropriate current industry standards and conventions.

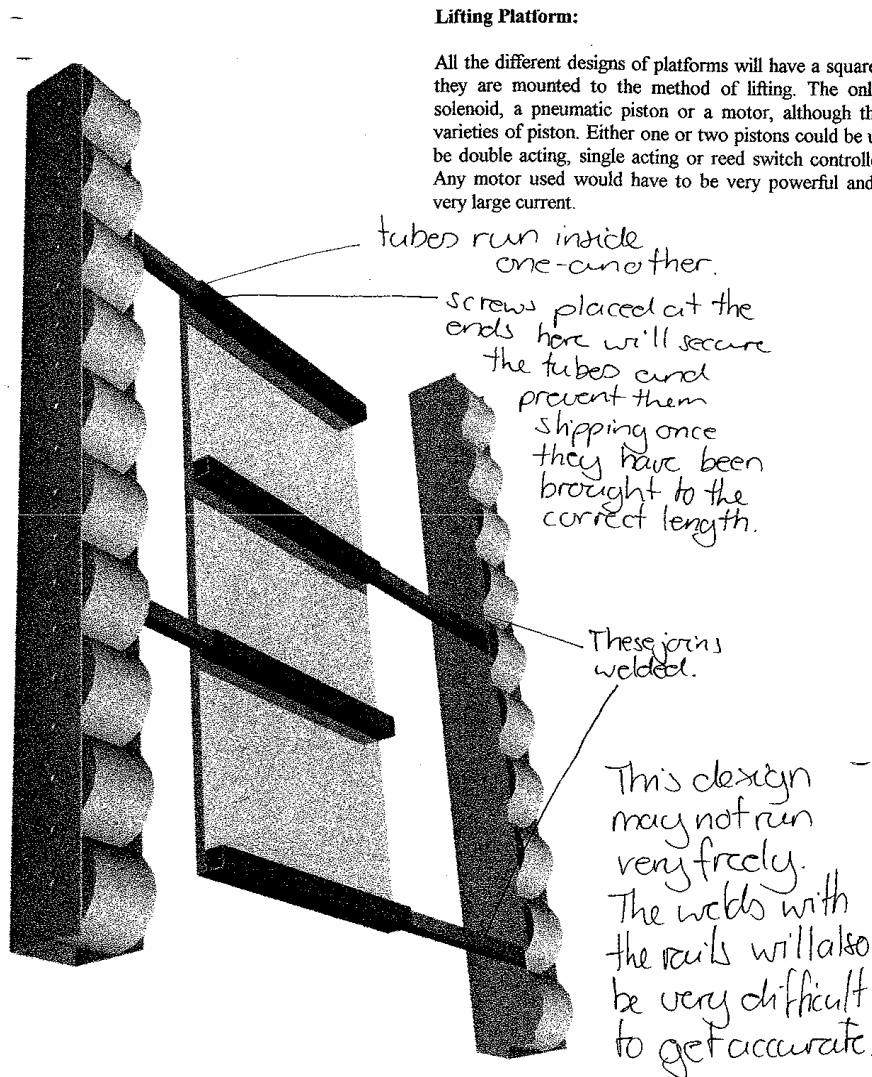

### Holding The Carrier:

The carriers will be placed on a platform.

This platform will be 300mm wide (width of largest carrier) so that nothing must be changed for it to take any size of carrier, with long rollers going perpendicular to the direction of motion to aid the carriers in their motion.

OR

Will consist of two parallel rails containing wheels that will move in and out to the edges of the size of carrier. These rails will move using tubes that fit inside one another and will allow the distance between the rails to be changed. The tubes can be fixed with screws that will stop them extending further.

OR

Will again consist of two parallel, wheeled railings. One railing will be fixed and will be exactly in line with the (fixed) top railing of the adjacent production line when placed in-situation. The bottom railing will then move using a screw thread that will run through it and be fixed in a bearing in the opposite (stationary) railing.

OR

Will have two parallel, wheeled railings, both of which will be mounted on a screw thread that is half left hand thread and half right hand thread. The railings will then be moved out from each other simultaneously.

# MODIFICATIONS AFTER CLIENT FEEDBACK

Because a single piston will provide the required strength and stability, I modified my designs to take this into account. However, with a single piston, there is a problem maintaining balance if the carrier is off-centre. It will now be situated along the datum of the platform (in the absolute centre). However, when the rail is extended the datum will be lost, since one side will be wider than the other will. I was later told by LITEON that a single piston placed in the centre of the device would not be affected by extending a single rail above. This is the final idea for adjusting the platform:

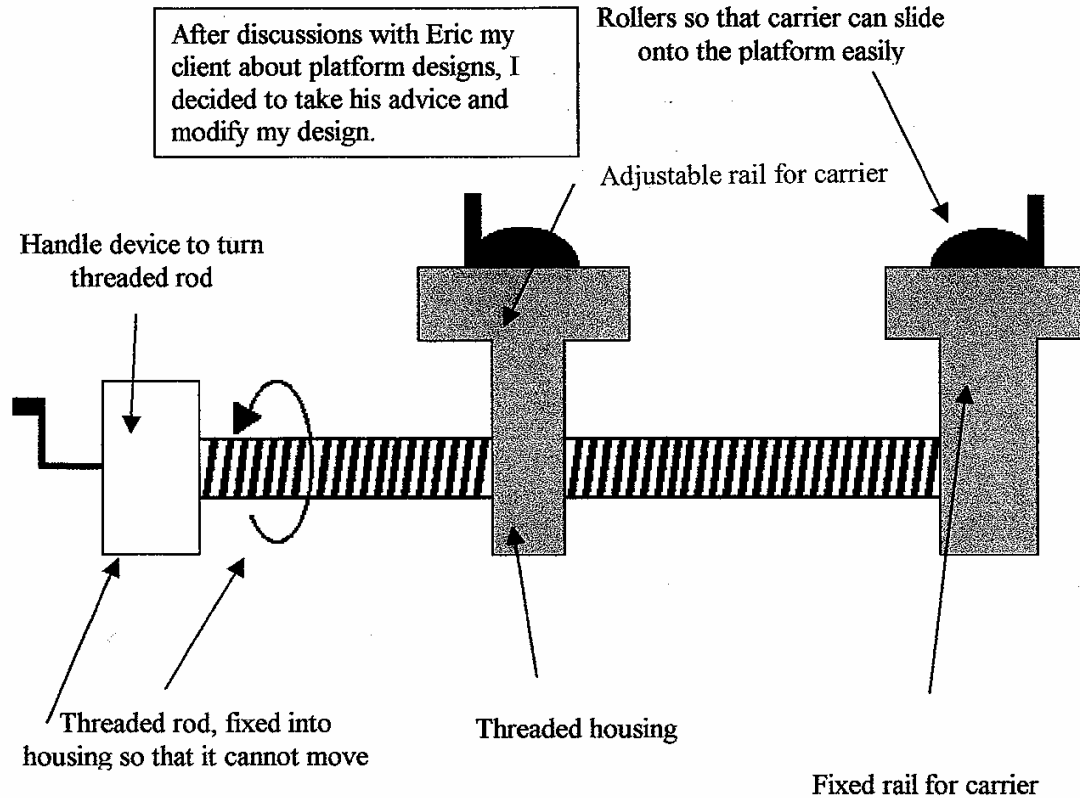

## How the Mechanism Works

Two threaded rods are fixed in position at both ends of the platform, and both pass through an adjustable rail for the carrier. The housing that the rods pass through is threaded. When the handles are turned simultaneously in the same direction, the rods turn inside the adjustable housing at the same rate, and move the rail towards or away from the user. Provided that the permanent rail is positioned in line with the production line, the adjustable section can be altered to suit the size of the carrier being used at the time.

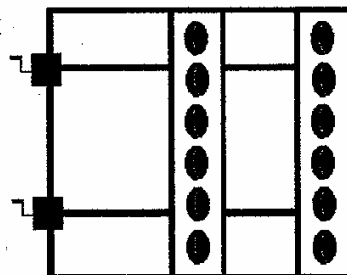

Top View

When a carrier is rolled onto the platform there is nothing to prevent it from falling off the other side. Even if the carrier does not completely fall, it is likely that it will not be placed correctly onto the conveyor belts, or may fall between them when the platform is lowered.

To solve this, a stop strip will have to be placed at the end of the platform to prevent the carriers from sliding off, and to keep the carrier in the correct place to lower onto the conveyor belts. The platform must be able to be used from both sides because any two of the eight production lines might be used at one time. Because of this reason, there will need to be a stop strip on both ends of the platform.

If there is a permanent, immovable stopper it will prevent all carriers from rolling onto the platform. The solution is to have a stop strip at each end that can be manually folded into a stopping position when it is needed.

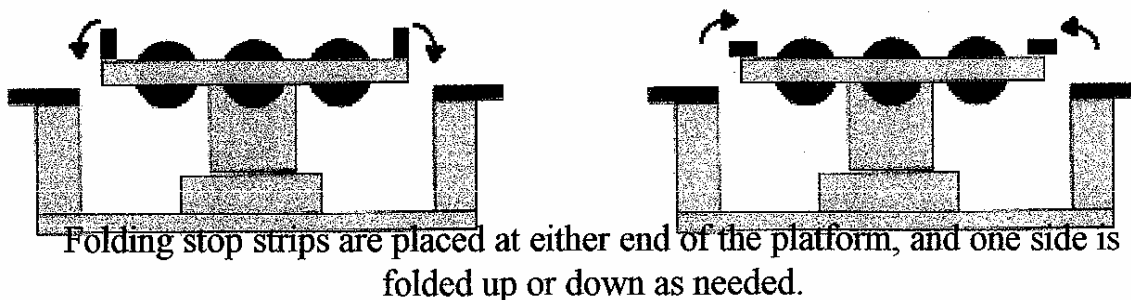

Using four hooks to hang from the groove in the conveyor mounting is not an efficient idea, as they may not provide enough support for the whole device.

A development to this system is to use a small sheet of metal, with threaded holes, which will slide in a slot already built into the conveyor housing. When bolts passing through the threaded holes in this sheet and through the frame of the lift are tightened, it will act like a vice to secure the frame in place. It will prevent the frame from sliding up and down the conveyor system and will be far more secure than four hooks.

With the new method of fastening the frame to the conveyor system and the single method lift, there is no need for a wide frame that is the size of the largest of the carriers. There will now only need to be a single sheet of bent metal to fasten the piston to and to fasten to the sides of the conveyor system.

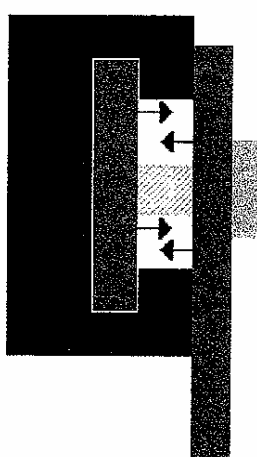

The new idea acts like a vice to hold the frame in position more securely



The discarded idea consisted of four hooks connected to the frame

# INITIAL IDEAS - ELECTRONICS

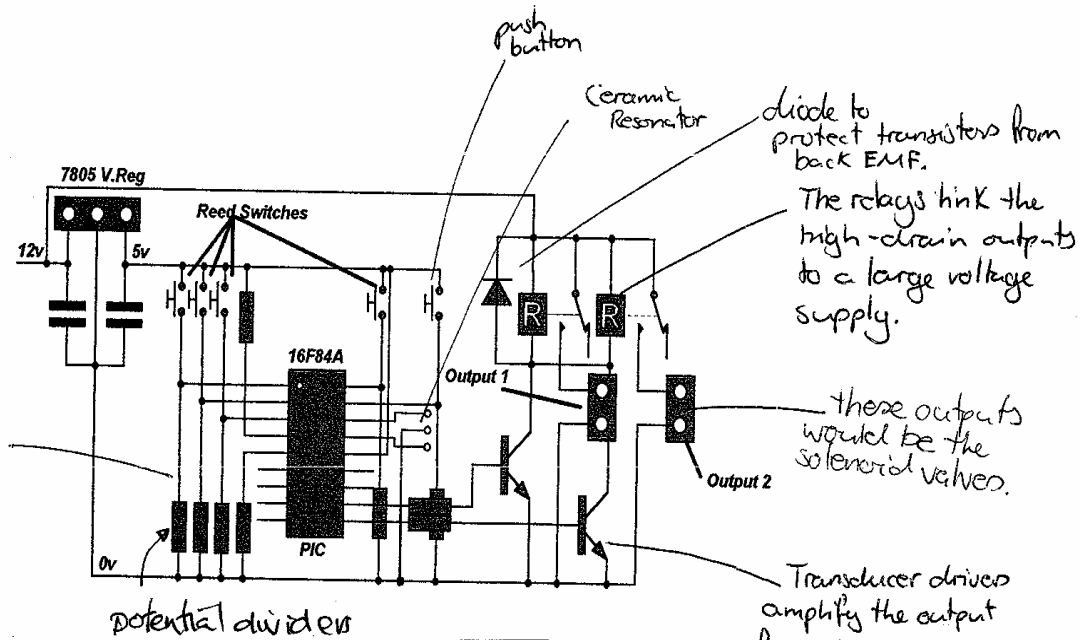

This is one of my initial design solutions for control circuitry. It uses the extremely flexible PIC microcontroller to process the logic and to latch outputs. To programme the PIC I can either use PIC basic or PIC logicator.

This is another initial design solution. It is effectively a bistable circuit where the output state is always in one of the two possible states – high or low. This translates in real terms to the lift always being either up or down.

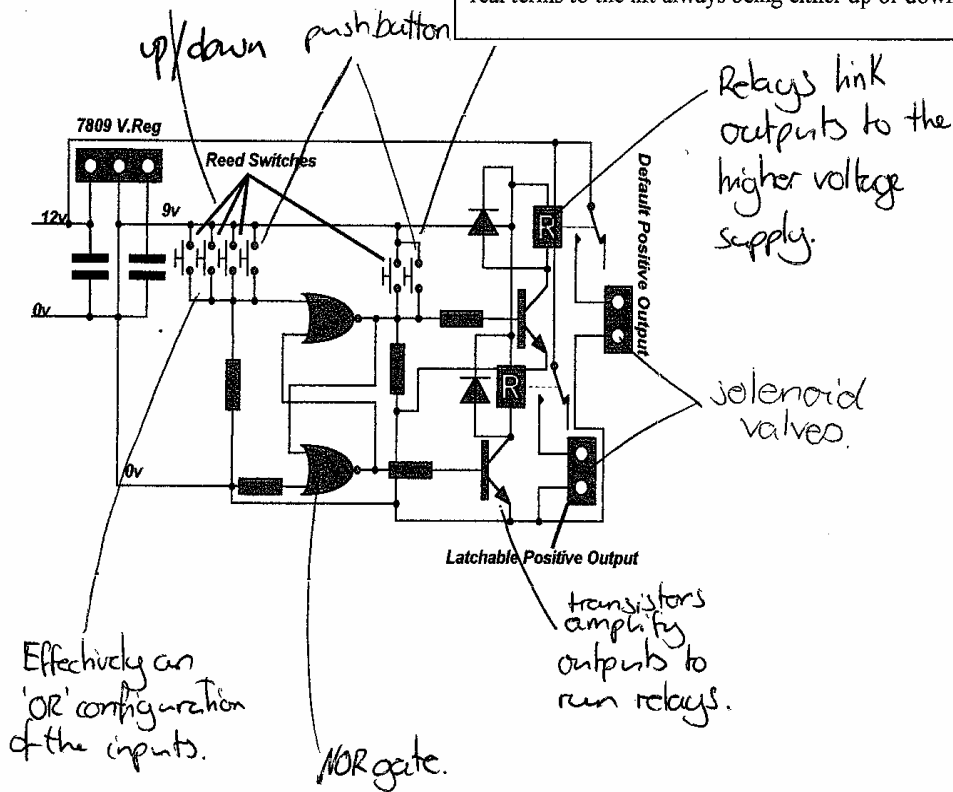

# INITIAL IDEAS — ELECTRONICS

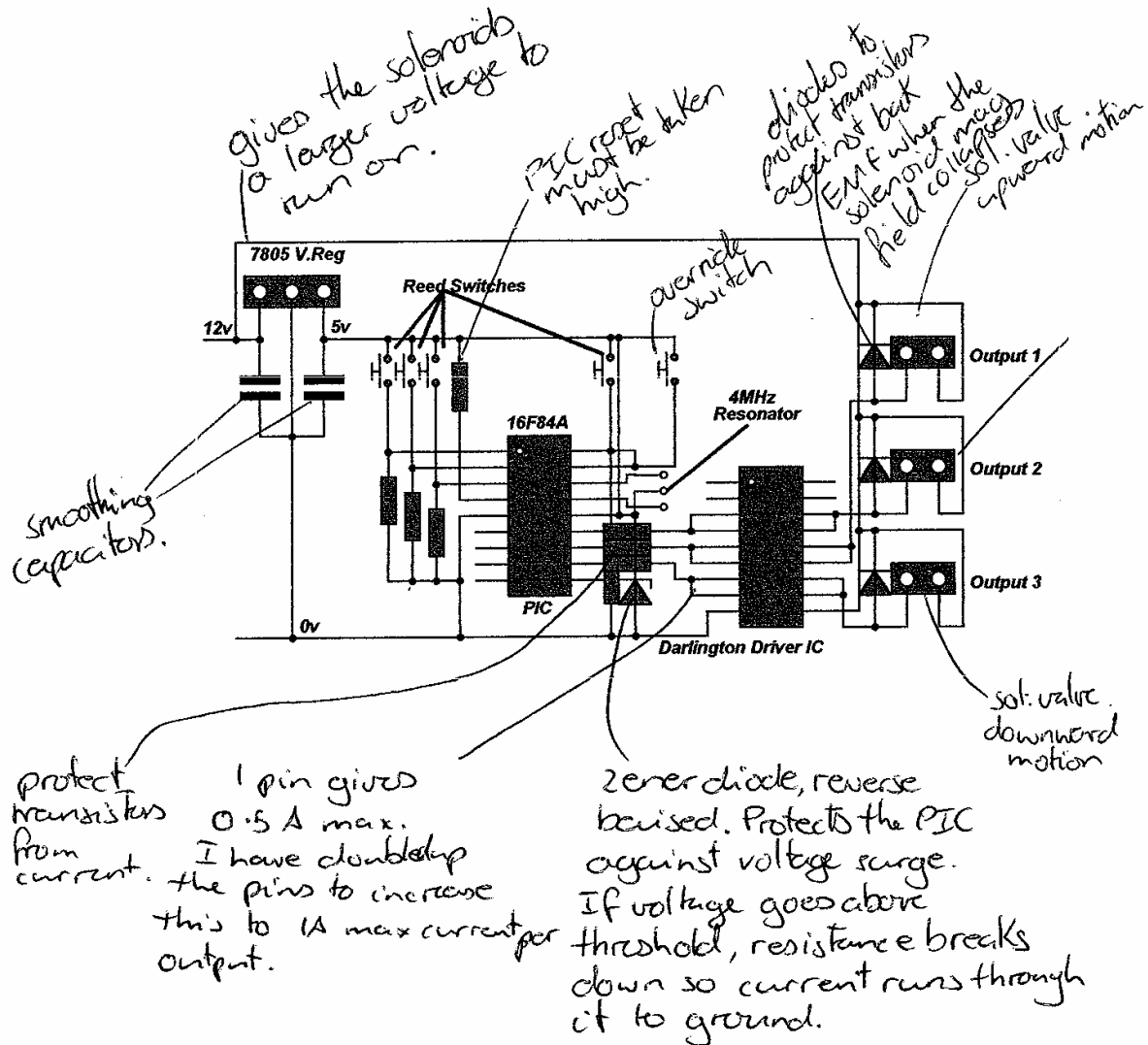

## Transforming The Power Supply:

For use with my circuit the available power supply will need to be transformed from a large A.C. voltage into a small D.C. voltage. Transforming the power supply, rectifying it, and smoothing it with capacitors and a voltage regulator or a zener diode would do this.

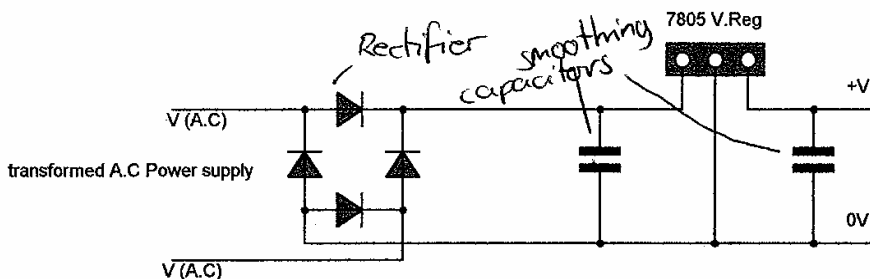

# INITIAL IDEAS - ELECTRONICS

When the transistor is triggered it turns on the relay. The second relay throw then bypasses the transistor so current continues running through the coil, irrespective of the transistor.

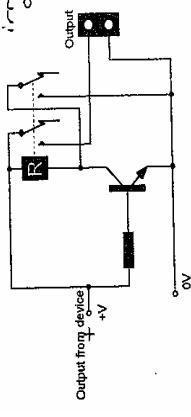

The power to the coil must be cut to reset this latch.

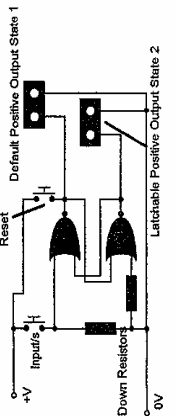

In this there is a high output from the top gate which causes the bottom gate to go low. This signal feeds back and latches the top gate high. When an input is triggered the top gate logic is '1,0,1,0' so has a low output. The bottom gate's logic is '0,0' so has a positive output. This positive output feeds back and keeps the top gate low, which latches the bottom gate's output to high. The reset breaks this feedback.

The PIC's reset pin must be brought high as it resets on low voltages. The back ECU will damage the transistors. A diode should be used here. relay can be pulled back to the high supply.

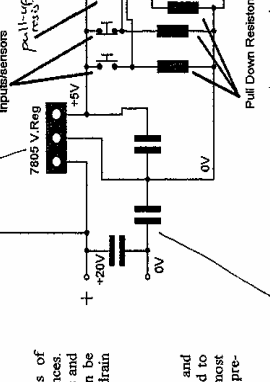

Processing Signals And Controlling/Amplifying Outputs: Op-amps could be used as both amplifiers of signals and as methods of processing inputs for later use with logic gates that will dictate sequences. Instead of this a PIC micro controller could be used. Transistors, Op-amps and darlington pairs can be used to amplify outputs, and linked to relays can be taken back to much larger voltages and current supplies that can run high-draw components.

Latching And Resetting Outputs: A NOT or NAND logic gate could be used to give effective latching and easy resetting from an input. A transistor-Darlington relay pair can also be used to latch and reset from an input configuration such as a potential divider most easily. Also a PIC micro controller can latch outputs permanently or for a pre-determined length of time.

When a sensor is triggered it takes the second NAND's logic HIGH. This changes it's output state to low. This feedback and it turns changes the bottom NAND's logic to 0 and changes the output to HIGH. This signal provides the second output and the feedback that keeps the top NAND's output latched. When the reset is triggered the bottom NAND's output state changes back to zero so the latch feedback is lost.

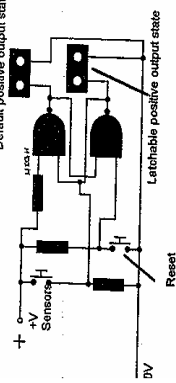

## Smoother Action:

Flow restrictors and cushioned pistons could be used with pistons, pulse width modulation and frequency with motors and strong springs could be used with a solenoid to smooth and slow the action of the devices.

## Avoiding Carriers:

Sensors will be placed before and after the platform. These will input into a control circuit that will dictate when the platform should be lowered below the conveyor belt to avoid oncoming carriers.

INPUTS	OUTPUTS
Sensor on conveyor belt before the platform to detect oncoming carrier movement.	
Sensor on conveyor after platform to detect carrier movement.	
Manual input "Override" button.	Controlled, two-directional vertical movement of the platform.
Sensor on the left hand side of the platform to detect carrier proximity.	
Sensor on the right hand side of the platform to detect carrier proximity.	

## Sensing Methods:

A number of different input devices could be used to anticipate carriers that are already on the conveyor belt moving towards/away from the platform. Pressure sensors can be placed below the conveyor belt to detect the weight of a carrier that would be passing over it. Or reed switches could be used to both register a signal as they detect the magnet that is placed on the rear of every carrier and when carriers move into position on the carrier, as could pressure sensors that are placed on the stoppers. A manual input button could be used as both an override to the other inputs, or as a control mechanism for all functions (operator watches for oncoming carriers etc...).

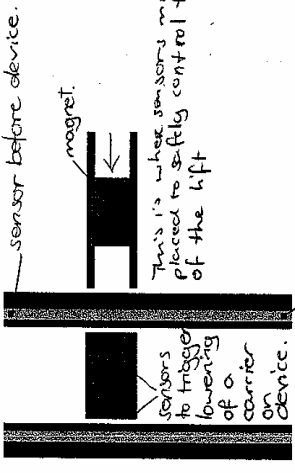

This is where sensors must be placed to safely control the movement of the lift.

sensor after device

as soon as the input is triggered, the positive output is fed back and causes a loop whether the input is on or off. A PDS switch must be placed next to the resistor to cut off the loop.

transducer in magnetic this would be magnetic solenoid valve

Here the PIC program deals with the logic.

When the inputs are triggered the voltage across the PIC's input pins goes high. The PIC program then controls the logic and latches the output.

NAND LOGIC TABLE

	PIN2	PIN1	PIN2	PIN1	Q
0	0	1	0	1	1
0	0	1	0	0	0
0	1	0	1	0	0
0	1	0	1	1	1

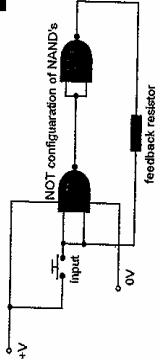





## MATERIAL SELECTION

Material	Density (kg/m <sup>3</sup> )	Young's modulus (MN/m <sup>2</sup> )	Coefficient of expansion (10 <sup>-6</sup> /K)	Tensile strength (N/mm <sup>2</sup> )	Compressive strength (N/mm <sup>2</sup> )
Mild steel	7850	200 000	11	500	2000 - 3000
Aluminium	2700	73 000	23	140 - 600	1000 - 2500
Brass	8450	100 000	18.5	300	
Titanium	4500	120 000		700 - 1400	
Nylon	1140	2400	90	60	50 - 100
Polystyrene	1060	3400	60 - 80	48	80 - 110
Acrylic	1200	300	60 - 80	60	80 - 140

I researched scientific data on the materials I thought I should use, in order to check that they had the appropriate properties for my needs.

My prototype would not experience undue loading, or stresses, so I could choose materials that had good strength to weight ratios.

Young's modulus is an indication of the strength and stiffness of a material and can be calculated.

First, the stress in a material must be found. Stress is the relationship between the applied load and the cross-sectional area of the material,

$$\text{Stress} = \text{load (N)} / \text{cross-sectional area (m}^2\text{)}$$

The Strain in a material, often called **fractional strain**, is the relationship between the change in length and the original length of a material

$$\text{Strain} = \text{change in length} / \text{original length}$$

It has no units and is usually a very small number – hence the term fractional strain.

If we want to indicate the properties of a material in terms of its strength, we use Young's modulus of elasticity. Young discovered that stress is proportional to strain up to the elastic limit and this allowed him to say that stress/strain equals a constant. He called his constant a modulus and gave it the symbol  $E$  for elasticity.

$$\text{Young's modulus: stress} / \text{strain} = E$$

$$\text{Since stress (N/mm}^2\text{)} / \text{strain (number)} = E$$

The modulus is stated in N/mm<sup>2</sup> and is usually a very large number indeed. In fact the higher the value of  $E$ , the greater the strength of the material concerned. Because of its relationship with strain, young's modulus also indicates the stiffness of a material.

## DEVELOPMENT

I used a 3D CAD package to model my final design proposal before starting the manufacturing process. This helped me to envisage all the different parts and how they would be assembled and joined together. The assembly is quite complex and has to accommodate the pneumatic circuitry, the electronics and the mechanical items that need to be manufactured.

These images were very useful in demonstrating my final ideas to the Lite On production engineer, as I was able to view the construction from any angle.

Commercially, this is how all designs would begin. From these drawings, cutting orders can be made to run CNC machines. It is also a convenient way of modifying design details before prototyping begins.

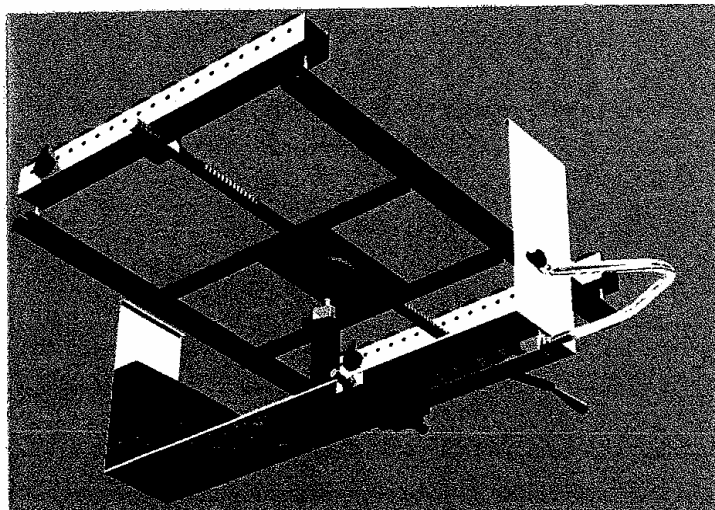
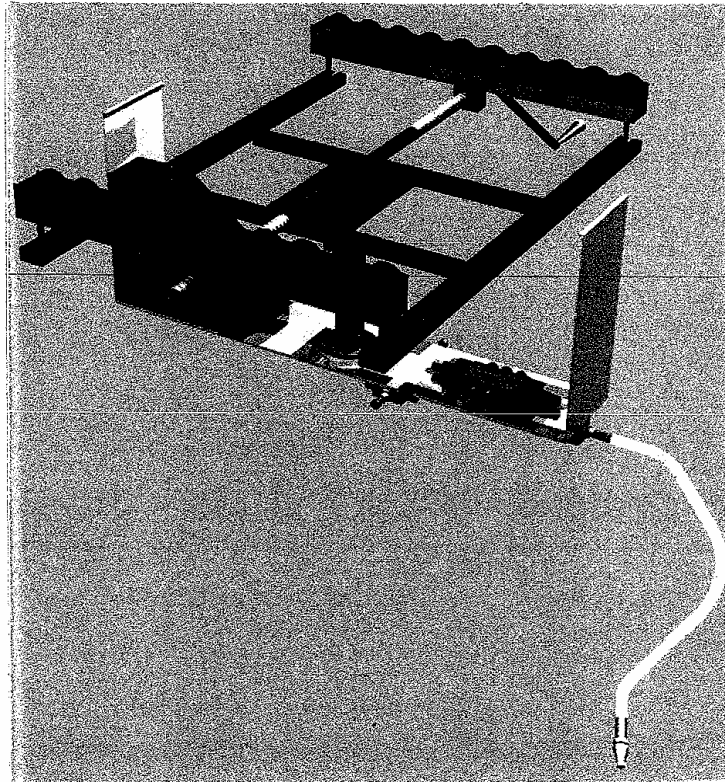

## DEVELOPMENT

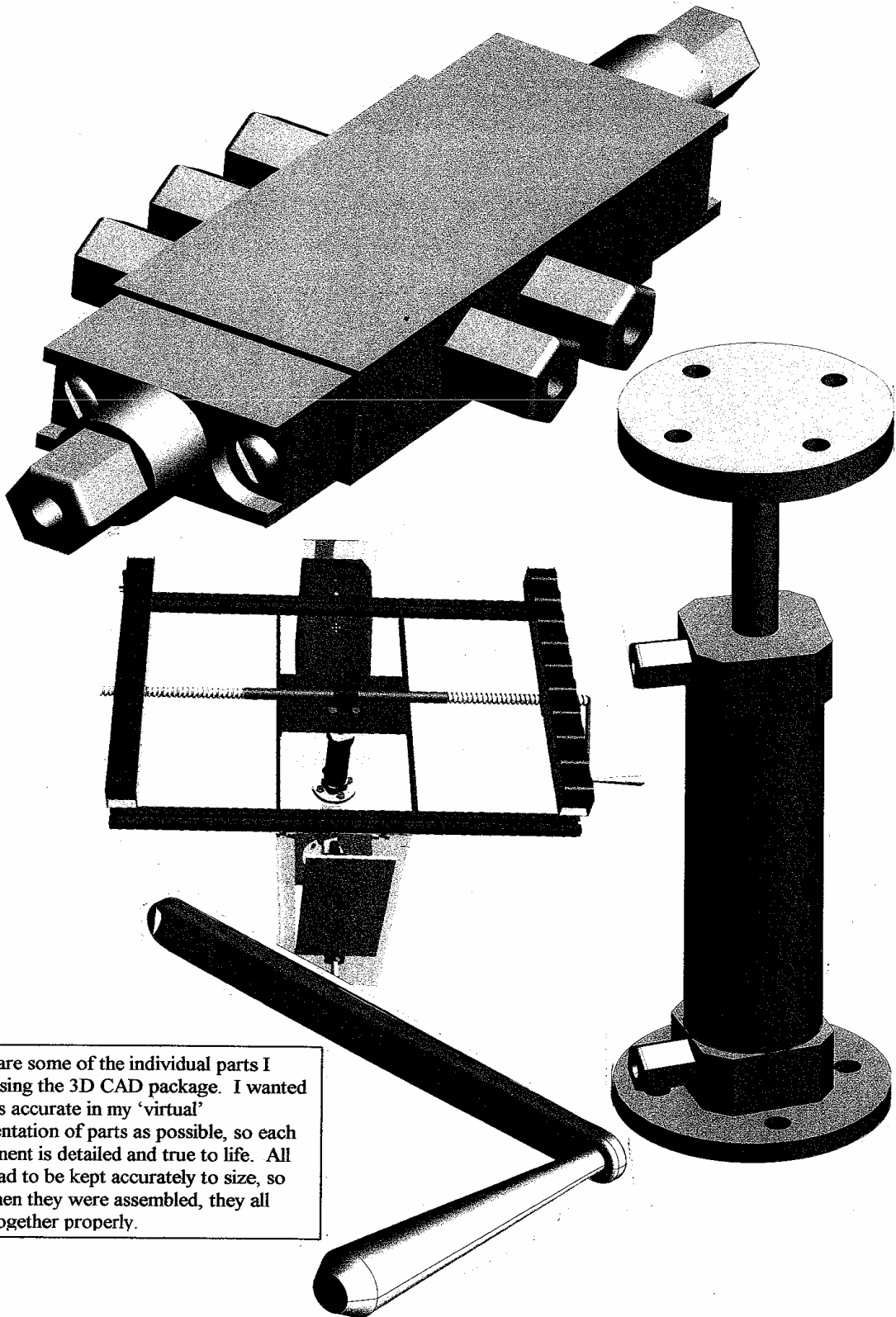

These are some of the individual parts I drew using the 3D CAD package. I wanted to be as accurate in my 'virtual' representation of parts as possible, so each component is detailed and true to life. All parts had to be kept accurately to size, so that when they were assembled, they all fitted together properly.

# DEVELOPMENT

OPTIONS
SETTINGS
CNC EDITOR

**TO MAKE A DESIGN**

- 1- Select a shape type from the icons.
- 2- Insert a new shape onto the profile.
- 3- Edit the new inserted shape.

Press the right button on the mouse for specific help.

LENGTH	-79.50	Load Design
DIAM	10.00	Save Design
		Convert Dxf

—

/

⤴

⤵

—

⏏

←

→

INS  
LEFT

INS  
RIGHT

DEL

NEW

This page shows the CNC program that I wrote in order to produce the aluminium handle for the width adjustment on my project. It is only necessary to draw the shape required to the correct dimensions, as the computer generates to G and M codes necessary to machine the profile required. I had to select the material type, its dimensions and feeds and speeds, but once I had set the datums, the CNC lathe cut the piece automatically.

**SETTINGS MENU**

METRIC	Yes
IMPERIAL	
BILLET LENGTH	120
BILLET DIAMETER	20
RADIUS PROGRAMMING	
DIAMETER PROGRAMMING	Yes
ROUGHING CUT	.5
FINISHING CUT	.1
MAXIMUM NO OF TOOLS	10
CHUCK POSITION	110
DEMO DELAY	1000
SERIAL PORT	1
PASSWORD	*****
Load Settings	
Save Settings	
Material	ALUMINIUM

**SETTINGS MENU**

Material	ALUMINIUM
ROTARY TOOLPOST	Yes
Roughing Tool	1
Finishing Tool	1
Grooving Tool	5
Parting Tool	5
Threading Tool	7
Toolchange On X	5
Toolchange On Z	20
Epson 8 pin 60 DPI	No
Epson 8 pin 120 DPI	No
HP LaserJet 75 DPI	Yes
HP LaserJet 150 DPI	No
HP LaserJet 300 DPI	No

## DEVELOPMENT

### The Function of the Circuitry

The function of the circuitry is to co-ordinate the inputs from various devices. This would not need to be done if there was not the danger of other carriers colliding with the raised platform, and only a switch would be needed to raise and lower the platform. However with the danger of oncoming carriers, there must be a system to safeguard the products. This system is a pair of sensors placed before and after the platform, which will allow the circuit to 'know' when a carrier is nearby or above and therefore move into the lowered position, below the conveyer belt. However, the platform must also perform its main function, which is to lower carriers onto the conveyer belt. To achieve this, the platform will remain in the raised position until a button is pressed manually by the production line worker, or until an oncoming carrier is detected. To move the carrier an output will be produced, leading to one of two electromagnetic air valves, which alternately raise or lower the platform.

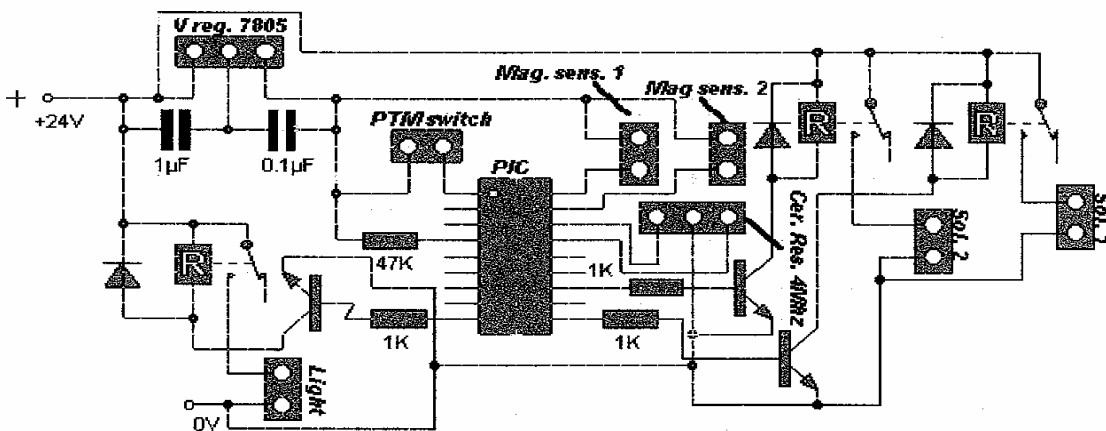

The central and most important component is the PIC (Periphery Interface Controller) microprocessor that we are using. This allows us to create a specialised piece of software. This can be downloaded into the PIC, which uses logic to co-ordinate inputs and outputs. This approach has many advantages over hardware based logic systems because extremely complicated programs can be created but use only a small amount of physical space. They can also easily be modified if there is an error.

The inputs in our circuit consist of two magnetic sensors, which will detect the magnets fixed onto the carriers on the conveyor belt, and a 'push to make' switch which is the control for lowering the platform. They lead into the PIC where the software deals with them. Three outputs lead out from the PIC, through a transducer driver and into three relays. The relays switch a higher voltage across onto the outputs as the PIC runs on 5 volts but some of the outputs require a greater voltage. The two electromagnetic valves, and a small bulb, which signifies the state of the platform to the production line worker are the three outputs.

Eric says he likes the idea of using a PIC as it is programmable and can be reprogrammed for changes in requirements. He thought the circuit was fine and commented on how neat and small it was, although surface mounted components would reduce its size to about one third. Eric thought that running the solenoid valves from a Darlington driver chip was a neat and cost effective way of doing things.

## DEVELOPMENT

### The Function of the Circuitry

The function of the circuitry is to co-ordinate the inputs from various devices. This would not need to be done if there was not the danger of other carriers colliding with the raised platform, and only a switch would be needed to raise and lower the platform. However with the danger of oncoming carriers, there must be a system to safeguard the products. This system is a pair of sensors placed before and after the platform, which will allow the circuit to 'know' when a carrier is nearby or above and therefore move into the lowered position, below the conveyer belt. However, the platform must also perform its main function, which is to lower carriers onto the conveyer belt. To achieve this, the platform will remain in the raised position until a button is pressed manually by the production line worker, or until an oncoming carrier is detected. To move the carrier an output will be produced, leading to one of two electromagnetic air valves, which alternately raise or lower the platform.

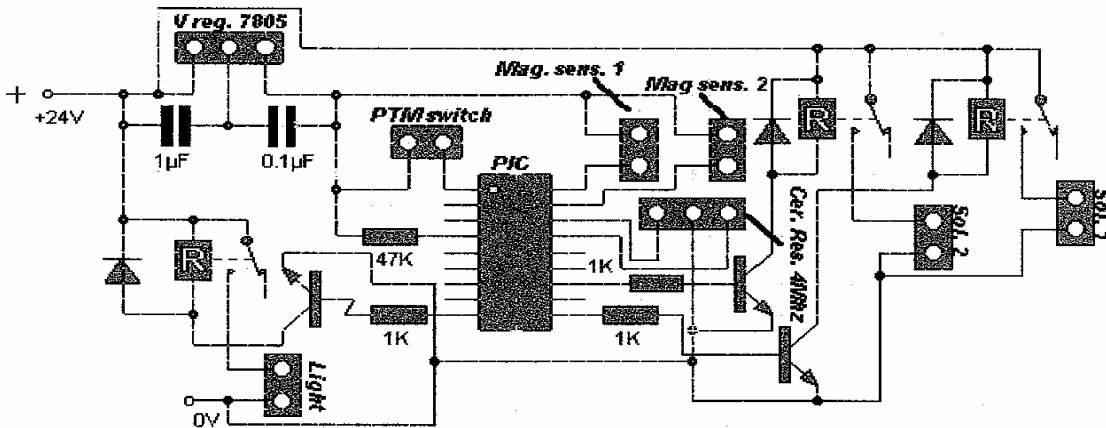

The central and most important component is the PIC (Peripheral Interface Controller) microprocessor that we are using. This allows us to create a specialised piece of software. This can be downloaded into the PIC, which uses logic to co-ordinate inputs and outputs. This approach has many advantages over hardware based logic systems because extremely complicated programs can be created but use only a small amount of physical space. They can also easily be modified if there is an error.

The inputs in our circuit consist of two magnetic sensors, which will detect the magnets fixed onto the carriers on the conveyor belt, and a 'push to make' switch which is the control for lowering the platform. They lead into the PIC where the software deals with them. Three outputs lead out from the PIC, through a transducer driver and into three relays. The relays switch a higher voltage across onto the outputs as the PIC runs on 5 volts but some of the outputs require a greater voltage. The two electromagnetic valves, and a small bulb, which signifies the state of the platform to the production line worker are the three outputs.

Eric says he likes the idea of using a PIC as it is programmable and can be reprogrammed for changes in requirements. He thought the circuit was fine and commented on how neat and small it was, although surface mounted components would reduce its size to about one third. Eric thought that running the solenoid valves from a Darlington driver chip was a neat and cost effective way of doing things.



# DEVELOPMENT

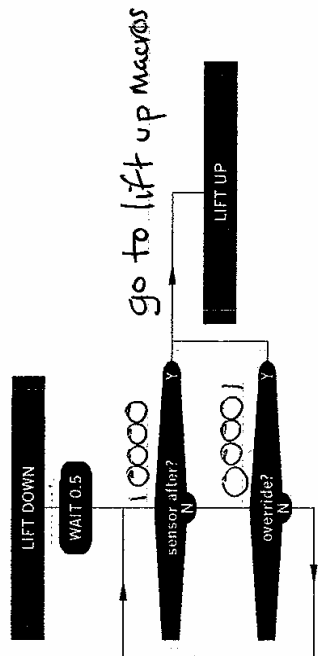
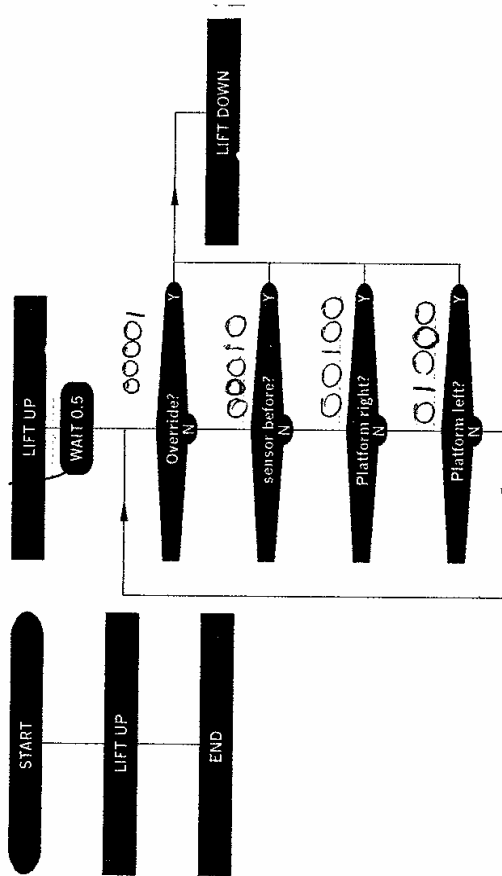

*Input pin logic required*

Programming Editor (c)Revolution Education Ltd

Filename: c:\my documents\rob\tech\pic program  
Date: 14/10/01

```

main:
  let PINS = %00000001
  if B12 = %00100 OR B12 = %00010 OR B12 = %00 then lower_platform
  if B12 = %10000 then platform_carrier_avoid
  goto main

lower_platform:
  let PINS = %00000010
  if B12 = %10000 then lower_platform_extended
  if B12 = %01000 then main
  if B12 = %00001 then main
  goto lower_platform

lower_platform_extended:
  let PINS = %00000010
  if B12 = %01000 then lower_platform
  if B12 = %00001 then main
  goto lower_platform

platform_carrier_avoid:
  let PINS = %00000101
  wait 1
  let PINS = %00000001
  wait 1
  goto lower_platform

platform_is_up:
  goto lower_platform_subroutine_if_carrier_is_fully_on_platform_or_button_is_pressed
  if oncoming_carrier then goto warning_sub
  loop

platform_is_down:
  safety_sub_incase_a_carrier_passes_sensor_when_platform_is_down
  platform_is_down
  when_first_carrier_has_passed_platform_go_back_to_low_platform_sub
  if button_is_pressed_goto_main_sub_and_raise_platform
  loop

platform_lowering_imminent:
  buzzer_on_platform_is_up
  1 second delay
  buzzer_off_platform_up
  1 second delay
  goto lower_platform_sub_to_lower_platform
  
```

*If override of sensor are triggered Lift goes down*  
*If sensor before platform is triggered Buzzer on then lift down.*  
*If second carrier comes, go into 2nd level loop until both have passed*



# DEVELOPMENT

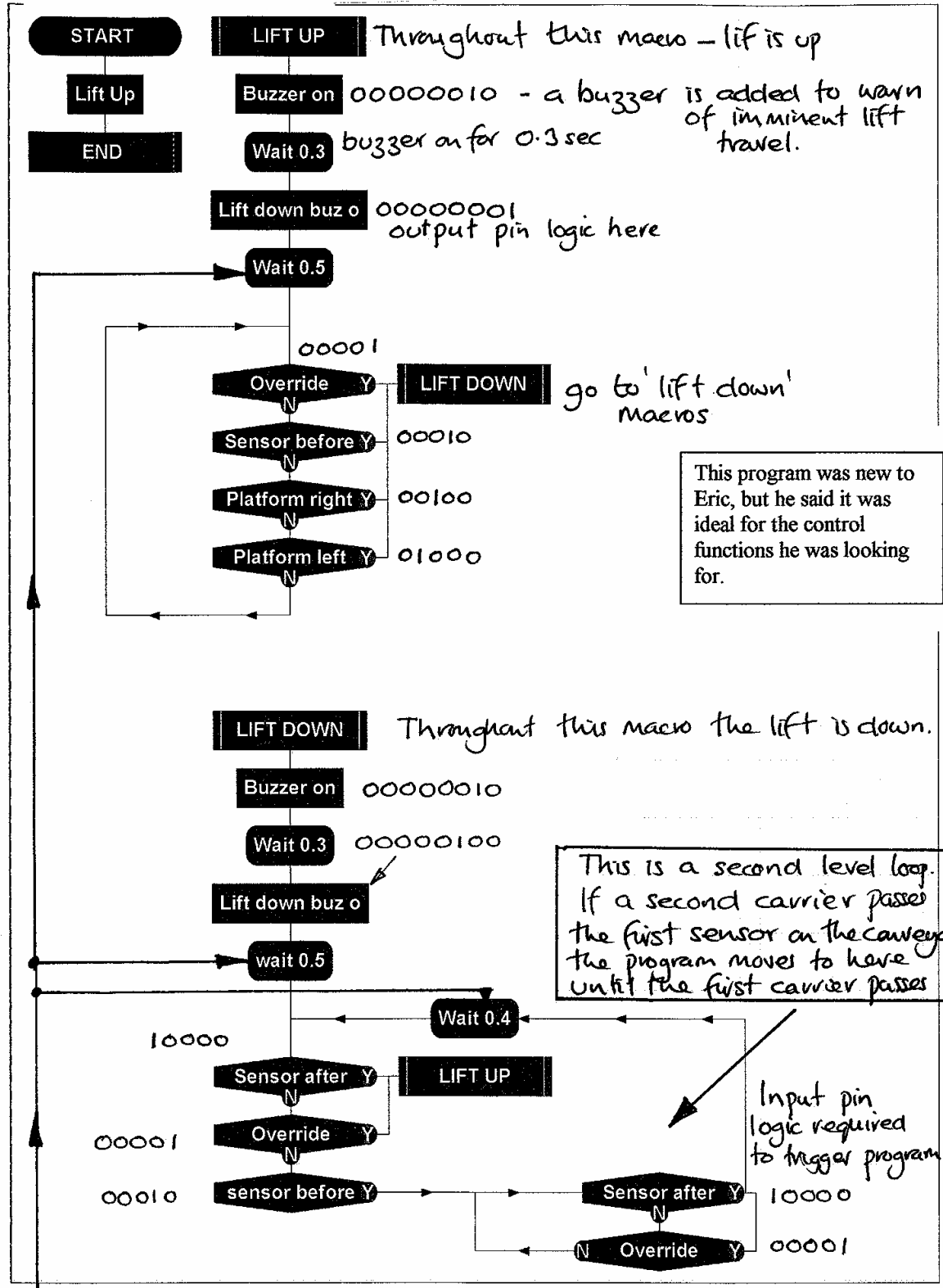

This means that when a sensor is triggered there is no chance that it will trigger two responses for the same input. For example, if the override button was pressed for a longer length of time

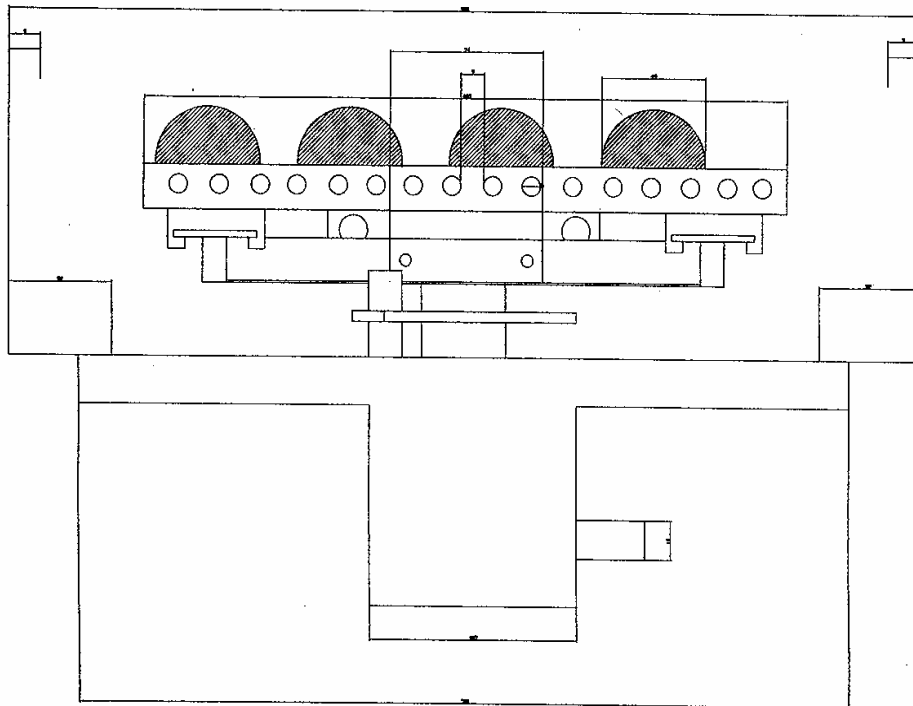
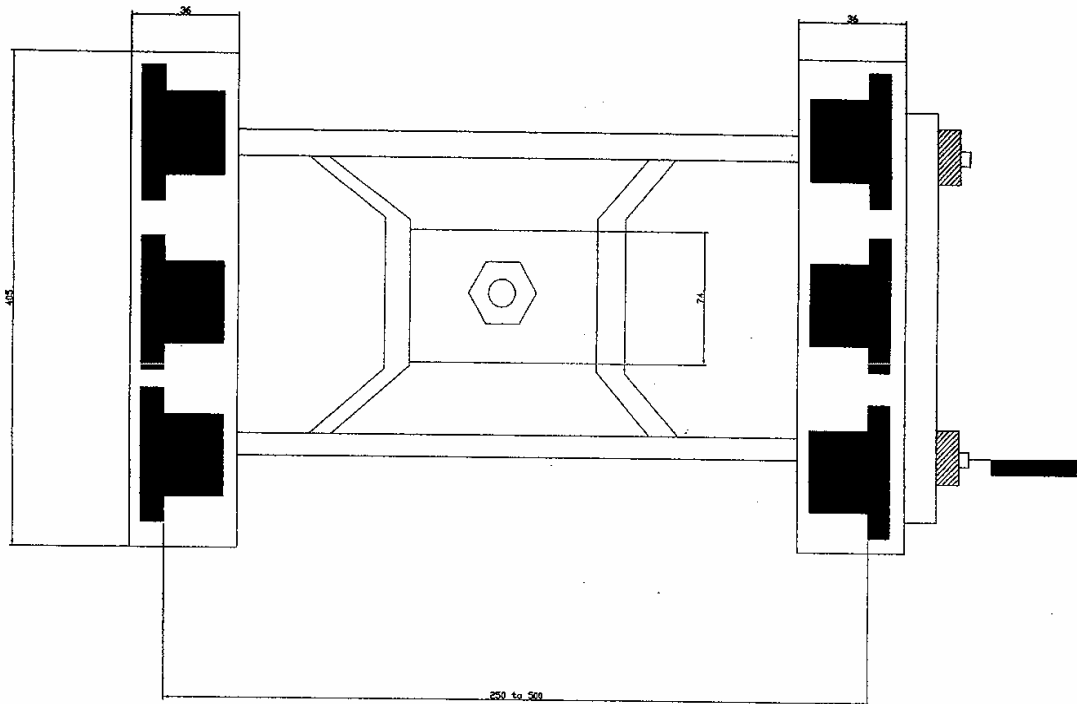

# TESTING / EVALUATION

## Prototyping:

Before finally producing my design it is essential that I test my design to ensure that it works correctly. To this purpose I will make a copy of my circuit on breadboard, rigged up with LED's to test outputs and simple switches as inputs. I will also rig up the pneumatic circuit that I am using; to do this I will set up the piston and valves with a lab pack and simple switches to simulate the outputs from the circuit. Here I will also configure my flow restrictors to get a smooth, slow speed from the piston stroke.

**The tests that I will perform on the circuit set up on breadboard:**

1. Checking the voltage levels at various important pins, such as the power output from the voltage regulator and the input and output pins from the PIC.
2. Using the switches I will check all different combinations that can occur in the program; override switch then sensor after, sensor before then sensor after etc...
3. Take out the PIC and check the voltage regulators performance under increased voltages – check that the voltage stays steady at 5 Volts no matter what the supply.

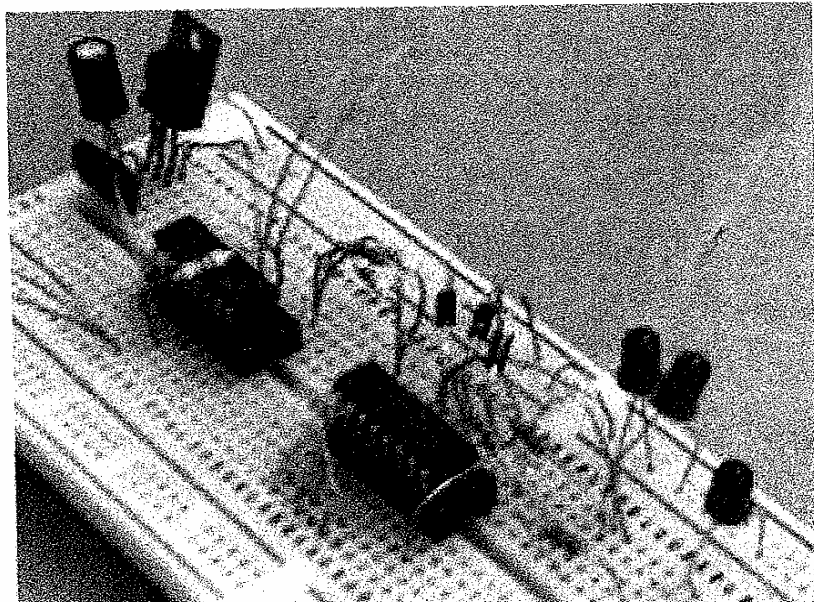

## Results of tests on breadboard-circuit:

1. The voltage level produced from input pins gave a very crisp turnover. The voltage level went from zero to near maximum with a minimum of bounce and only a fractional voltage drop. This kind of result will provide very effective inputs for the PIC and will cause no problems. The output levels from the PIC were, as expected very low but were amplified very effectively by the darling drivers. This means that there is enough voltage and current to trigger the solenoid valves very snappily.
2. All the different permutations of the program worked successfully.
3. Even at supply voltages of well over 20 the voltage regulator kept the output voltage a very steady 5 volts. This means that there is very little danger of the PIC being damaged by large voltages (this is reduced further by the zener diode in the circuit between +5v and 0v).

## TESTING / EVALUATION

### Tests to perform on the pneumatic circuit:

I only need to check the general functionality of the pneumatic circuit because the circuit will control any sequence to the valves.

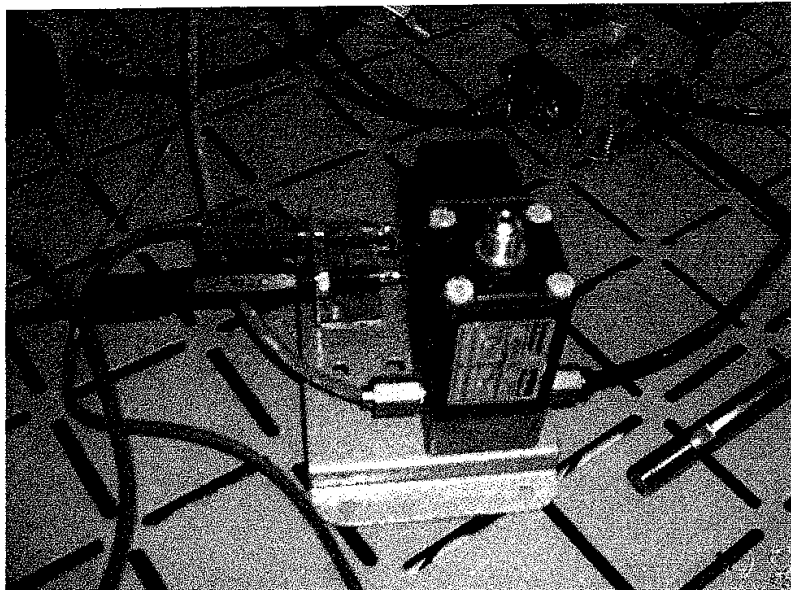
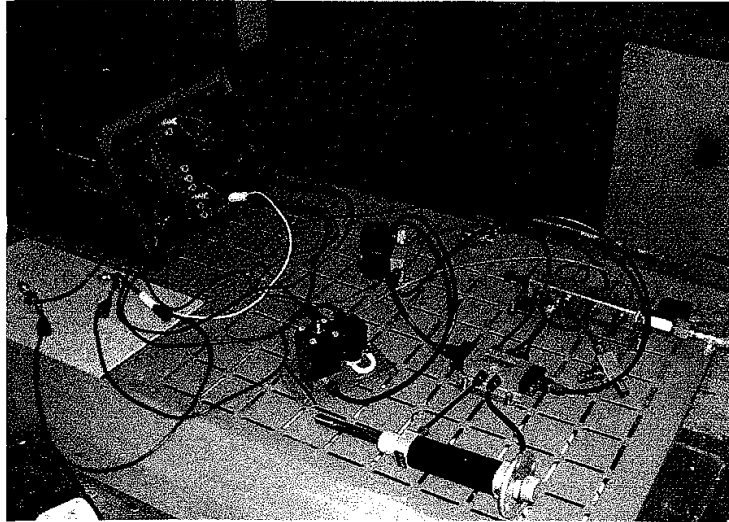

### Results from pneumatics testing:

The system worked very well although a problem I came across seemed to be that the flow restrictors were partially clogged, or didn't consistently give the same restriction every time. This could potentially be a serious problem but I don't have access to any newer, more reliable flow restrictors. Otherwise though the motion was very smooth and the piston was well cushioned against impact at the end of a stroke.

## Overall performance for assessment criteria (b)

*Generation of at least **three** alternative design ideas and their development into a final design solution using appropriate current industry standards and conventions.*

David has presented a range of alternative design ideas that focus on three areas of engineering design, which are the mechanical construction of the platforms, the electronic sensing circuitry and the pneumatic circuitry for the lifting device. Each of these sub-systems is well considered and innovatively used and it is obvious from the detailed and accurate information that accompanies each design idea that the candidate possesses high quality knowledge and understanding of the technologies involved and shows real ownership of the work. A feature of this group of designs is the continuity and flow of ideas from one concept to another. As the series of designs progresses, it is evident that they are linked and the train of thought of the engineering designer can be followed. It is clear from the detailed annotation that there is use of information gathered to inform the practicalities of each design, justifying the ideas as realistic and workable.

Although David is limited by the parameters imposed on the design by the client and company, having to use some ready made parts and having to fit an existing mechanical system, there is still evidence of innovative design, such as employing left and right hand threads on the same lead screw to enable equalisation of movement in two directions when the adjusting handle is turned.

Electronic sensing circuit design is comprehensive and considers several realistic and workable design proposals. It is obvious from the designs presented and the detailed accompanying annotation that the candidate has a very good understanding of this technology and has applied knowledge and understanding expertly.

A workable fluidic/pneumatic solution to the sensing/lifting problems is suggested by the candidate, but problems of reliability and flexibility are pointed out.

There is evidence that the candidate has consulted the client at this point, which is entirely appropriate, and the resulting discussions have led to some changes and modifications in the designs to be developed.

As a starting point for development of the final design proposal, David has selected sub-systems from the initial design proposals based on personal and third party feedback and which performed well against the requirements of the product specification. Extensive refinement and change takes place in this section through re-designing of details and features and modelling is extremely important. In the development of the final design proposal, the candidate has used a 3D CAD package to model the final proposed outcome and the expert use of this software enables the complex construction of the final platform to be shown with all details necessary. Each individual component part of the complex assembly was drawn to scale by David and examples of some of these are presented as evidence of a high quality engineering presentation skill. As part of the final development, he has produced a CNC program for the manufacture of part of the project, illustrating further appropriate and relevant skills.

The development of the electronic sensing circuitry is shown, from the drawing of the final schematic circuit diagram, through to the candidate's design for the final PCB track pattern. A PIC program has been developed to control the sensing part of the project and David has explained the function of each part of the flow chart. The final program was written using PIC basic, which is more difficult to use than the Logicator flow chart system, but offers more flexibility and speed.

David has shown testing of the electronics and pneumatics sub-systems at this stage, to establish their workability. Technical measurements are recorded for the electronics testing.

David has produced a CAD engineering drawing of the final design proposal that uses some current conventions and standards in its presentation. However, there is limited detail in the drawing and a skilled third party would be unlikely to be able to manufacture the platform from the information provided.

David has presented a range of alternative design proposals that are well informed and focus on specification points. Ideas are realistic and workable and employ appropriate materials, components and processes in their makeup. Development considers previously designed sub-systems that are the basis for change and progress towards a final design proposal. Development takes place using mechanical, electronic and pneumatic technologies. Relevant testing and modelling is used to prove features during development. However, the very important aspect of communicating design details through a series of accurate and detailed engineering drawings that would enable the product to be manufactured to exacting standards by a third party is missing, which just prevents the candidate from achieving the highest category of attainment.

The evidence presented in this assessment criterion meets the requirements of mark band 2.

## **Exemplar student response for assessment criteria (c)**

*Discussions with other engineers (your peer group) on your initial design solutions.*

Evidence for this criteria is evidenced throughout the folder, through criteria (a), (b) and (d).

## **Overall performance for assessment criteria (c)**

*Discussions with other engineers (your peer group) on your initial design solutions.*

Throughout the design folder, there is evidence that David has consulted with and taken advice from the 'expert client'. However, these cameos of discussion are somewhat superficial and whilst they do involve some technical content regarding the project in hand, there is no real structure or organisation to the meetings and he does not record the detailed content of the discussions, or the strategies for change arising from specific points of constructive criticism.

There is evidence that David held some discussions with an expert and acted on technical feedback that focused on some aspects of the specification, ideas and their development.

Had David presented a record of well organised detailed discussions with the expert client and presented evidence of a clear understanding of how the technical feedback on each aspect discussed would be used in the future development of the product, they could have achieved the high mark band.

The evidence presented meets the requirements of mark band 2.

Exemplar student response for assessment criteria (d)

Planning for production.

PLANNING

TIME PLAN

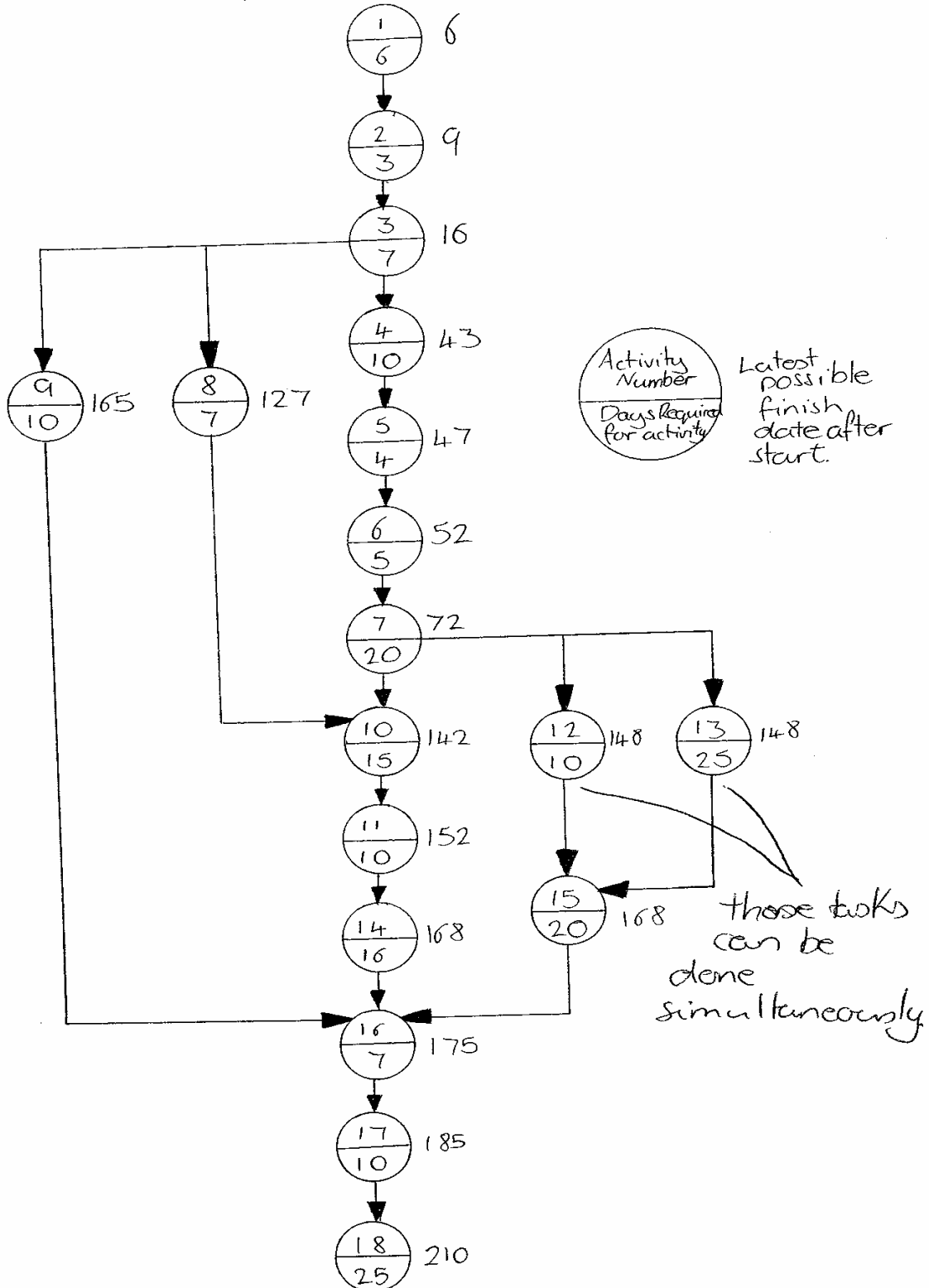



# PLANNING

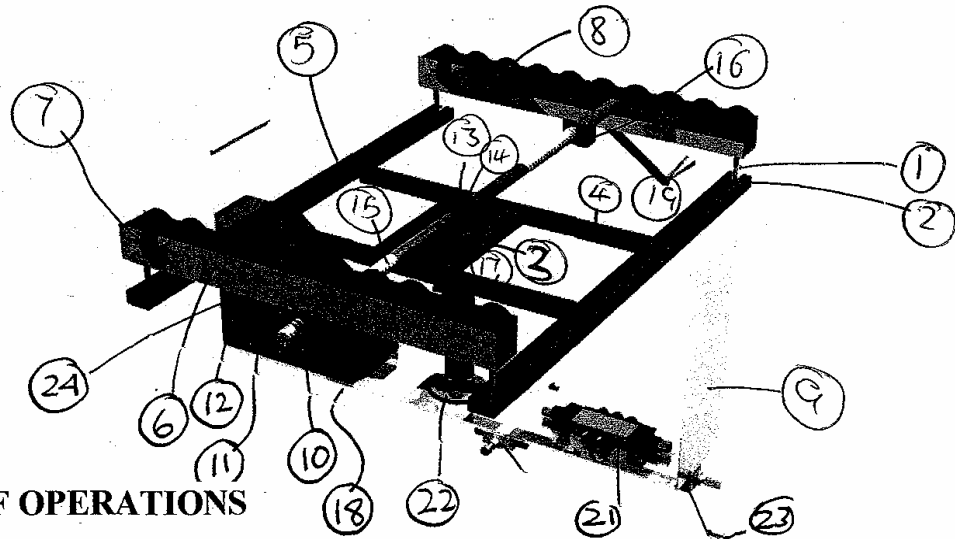

## SEQUENCE OF OPERATIONS

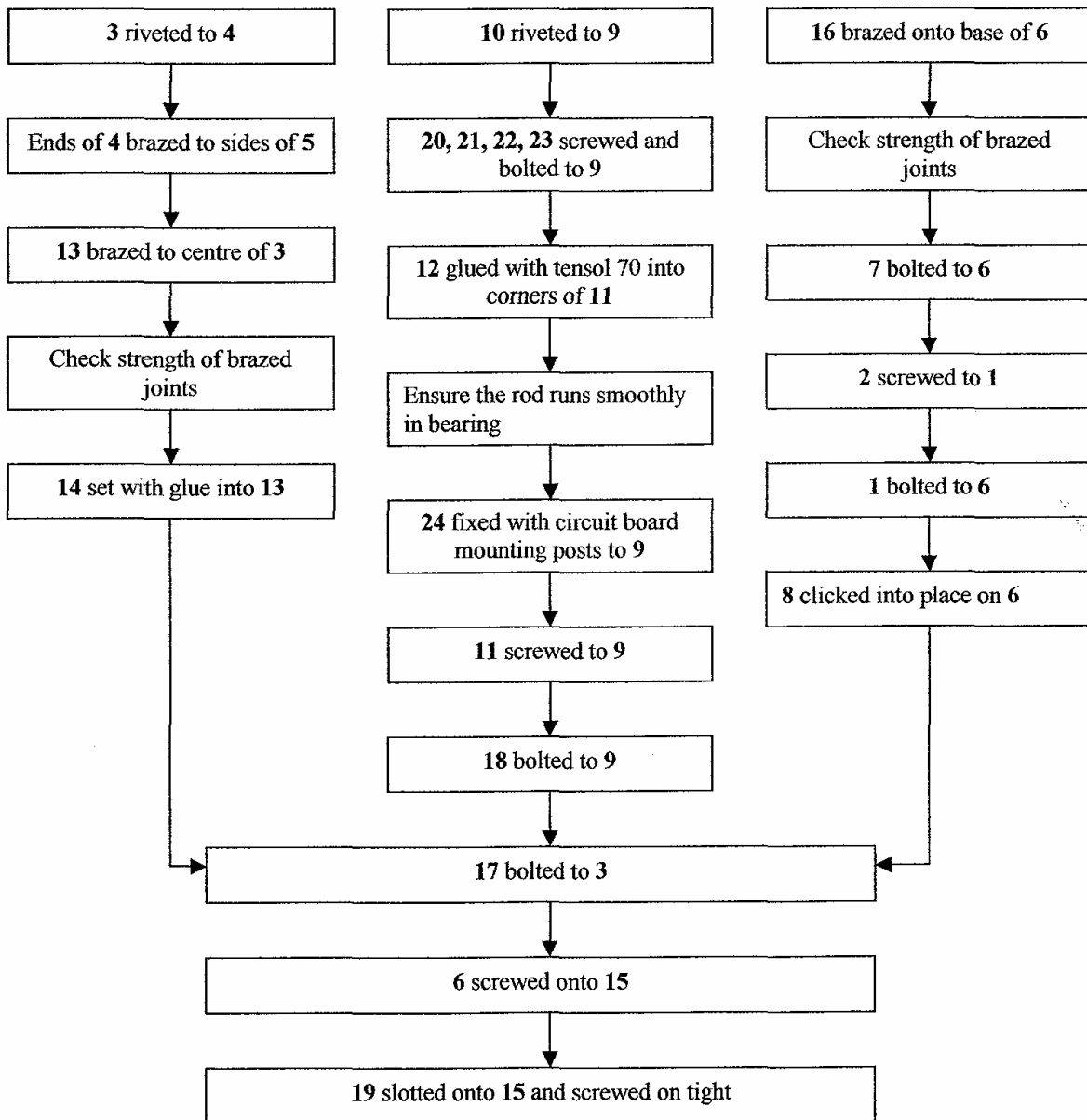

## PLANNING

### MATERIALS CUTTING LIST

	Part	Material	No.	Sizes
1	Runner legs	Mild steel	4	6mm $\varnothing$ $\times$ 60mm long. M6 thread
2	Runner leg feet	Nylon	4	18mm $\varnothing$ $\times$ 8mm long. M6 threaded axial hole
3	Platform centre mounting	Steel	1	160mm $\times$ 100mm $\times$ 10mm. 2mm thickness of material. 2 4mm holes in each vertically bent edge for riveting.
4	Rail-supporting struts	Mild steel	2	350mm $\times$ 3mm $\times$ 20mm. Two 4mm rivet holes.
5	Runners	Mild steel. Hollow rectangular tubing. 2mm thick.	2	550mm $\times$ 26mm $\times$ 13mm. 6mm machined hole cut through whole length.
6	Railings	1.5mm sheet Galvanised steel	2	400mm $\times$ 35mm $\times$ 35mm. 4mm holes 15mm apart down whole length on opposite sides. 4mm holes 20mm apart on base.
7	Stoppers	Mild steel	2	3mm $\times$ 38mm $\times$ 28mm with variable radius of curvature. 4mm $\varnothing$ axial hole.
8	Wheels	Nylon	16	30mm $\times$ 30mm $\varnothing$ with lip of 40mm $\varnothing$ . 4mm axial extrusions to act as axle and 'click' into railing.
9	Trough	1mm sheet Galvanised steel	1	550mm $\times$ 250mm $\times$ 100mm. 5mm $\times$ 5mm $\times$ 100mm bent 'hooks' on top of each edge. 4mm rivet holes (for support), countersunk screw holes (for components like valves), four 6mm bolt holes and one 23mm bolt hole (piston mounting).
10	Trough reinforcements	Mild steel	2	50mm $\times$ 550mm $\times$ 3mm. (All the same holes drilled as above-drilled simultaneously while clamped in production)
11	Box shell	3mm High Impact Polystyrene	1	Fabricated from 3 cut side with solvent cement. Two 170mm $\times$ 150mm. One line-bent to shape and of initial size 100mm $\times$ 280mm.
12	Box mounting posts	10mm $\times$ 10mm acrylic rod	6	15mm $\times$ 10mm $\times$ 10mm. M4 screw thread through centre. Glued with tensol 70 to the corners of the box.
13	Mounting for rod bearing	Mild steel	1	35mm $\varnothing$ $\times$ 55mm, 2mm thick hollow tube.
14	Rod bearing	Nylon	1	35mm $\varnothing$ $\times$ 50mm. 25mm holes drilled through centre to fit rod.

## PLANNING

15	Threaded rod	Mild steel. 25mmØ solid bar	1	200mm in centre unthreaded. 150mm at one end has a left hand thread. The same length at opposite end a right-hand thread. Thread is custom made - Pitch is 1/18 inch. A square filed down at one end to fit handle 18mm × 18mm × 3mm. An M6 threaded hole in centre of square.
16	Nuts for rod	Mild steel	2	Hexagonal bolts. 40mm × 40mm × 10mm. One has RHT the other a LHT. Custom made to fit rod.
17	Piston head	Nylon	1	100mmØ × 10mm. Has four 6mmØ holes.
18	Piston base	Steel	1	100mmØ ring on base. Four 6mmØ holes in this. Metal ring fastened by a 23mmØ bolt.
19	Handle for rod	Aluminium – mild steel	1	18mm × 18mm square hole cut through 3mm mild steel length. M6 Threaded hole at opposite hole to attach to a CNC lathe cut aluminium handle.
20	Solenoid 3-port valve	Mixed. N/A.	2	Two M4 threaded holes on base. Size approx 80mm × 45mm × 60mm
21	Pressure operated 5-port valve	Mixed. N/A	1	120mm × 40mm × 70mm. Two M4 threaded holes in base.
22	Flow restrictors	Mixed. N/A	2	65mm × 50mm × 15mm. Two M4 holes in base.
23	Manifold	Mixed. N/A	1	150mm × 55mm × 35mm. Two 4mm holes protruding sideways from base.
24	Circuit board	Mixed. N/A	1	90mm × 55mm × 8mm. Two 4mm holes through board fro mounting.

# PLANNING

## PCB PRODUCTION

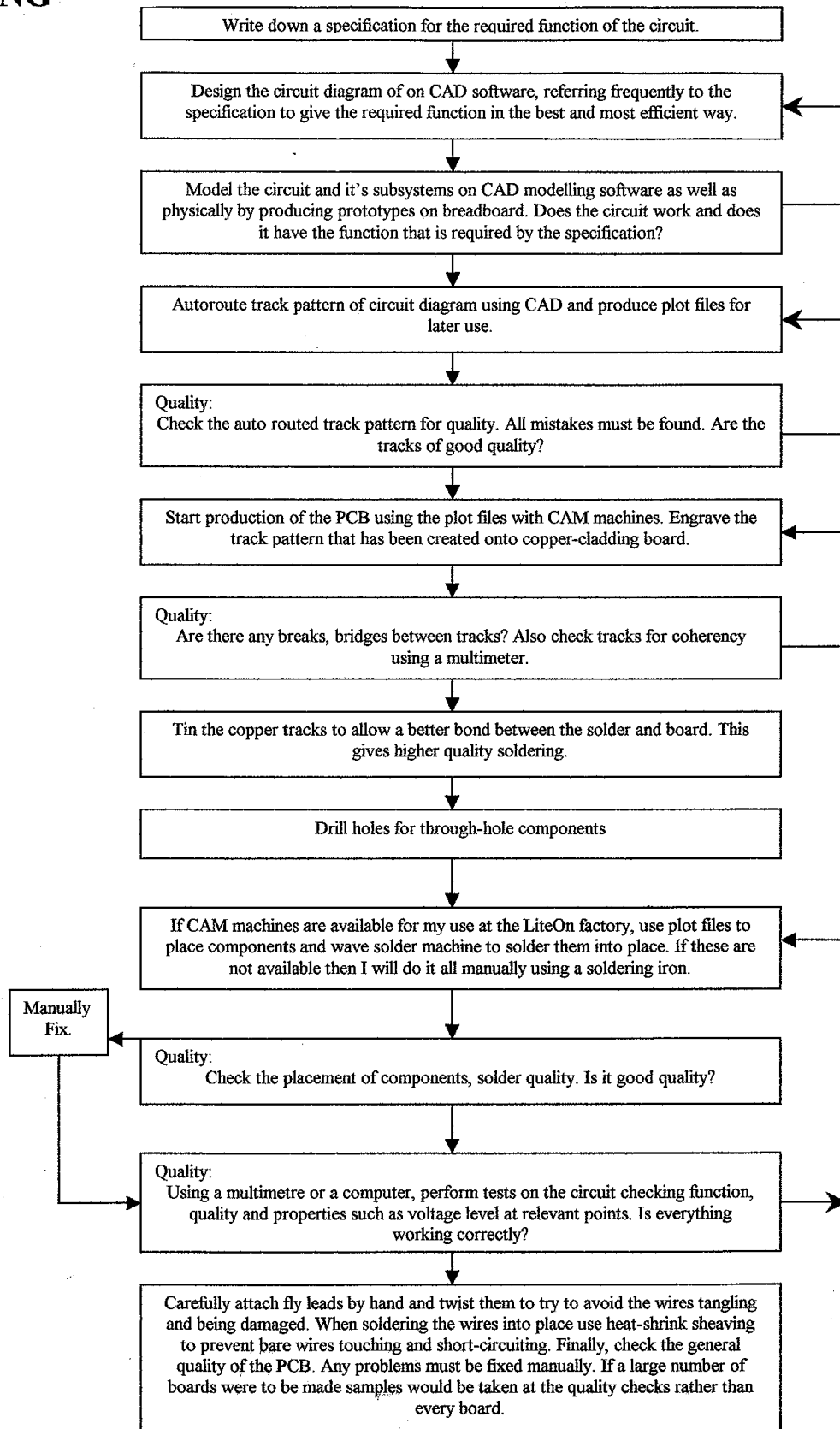

## PLANNING

### PROJECTED COST OF THE PROTOTYPE IF BUILT BY LITEON

Quantity	Description	Price (£ p) Each
1	Air Cylinder	118.00
1	Solenoid 24V 5/2 x 1/4BSP	122.17
2	Flow Valves	10.90
2	Magnetic Switch	15.98
2	3 Pin Plug	12.00
1	Carriage	15.00
1	Roller Chain 05B-1 (5 Metres – 0.6 Metres used)	50.83
1	Bag Connecting Links	2.01
4	Sprockets (2)	1.41
2	Lead Screws (studding)	5.00
2	Conveyor Rails	2.50
4	Airline Fittings	2.00
3	Airline Pipes	1.00
1	Aluminium Block and Sheet	10.00
1	Steel Bar and Sheet	3.00
n/a	Assorted Nuts and Bolts	1.50
n/a	Labour Costs	800.00
Total Cost		1173.30

This cost is estimated with reference to my prototype being produced in the LITEON workshop. LITEON estimated that, if the prototype were built using a contractor, the cost would have been in the region of £4000 per unit plus design costs.

#### List of Components Added to Circuit

Quantity	Item
3	SPDT Relay
3	Signal Diodes
1	0.1 $\mu$ F Capacitor
1	1 $\mu$ F Capacitor
1	7805 Voltage Regulator
1	Super-Bright LED
3	NpN BFY-51 Transistors
3	1 K $\Omega$ Fixed Resistor
1	4MHz Ceramic Resonator
2	Hall-Effect Magnetic Sensors
1	PTM Switch
2	Solenoid Valves
1	16F84A PIC Microcontroller (18 Pin)

Eric my client helped me to calculate the cost of my prototype as if I was buying new equipment and using materials that had to be bought from new. The actual costs incurred in making my prototype were very difficult to calculate, as I used a pneumatic cylinder and valves that the D&T dept already had. It was the same for the materials that I used, so doing the calculations on a commercial basis is more realistic. I need to add on the cost of the electronic components, but they only add up to about £7-00.

## REGULATIONS AND STANDARDS

If my prototype went into commercial production, the manufacturing company would have to meet certain standards and comply with some regulations. Standards and regulations are designed to ensure that companies are safe places to work and that the products they produce are of a consistently high standard.

Examples of regulations and standards that would apply to my project are:

**ISO 9000/2000**, which is a Quality Management system, that aims to develop

- greater responsibility and quality awareness among workers
- better use of time and resources
- less wastage and product failure
- greater consistency and traceability of products and services

This Quality Management System would look at processes, rather than at specific details and might check how tools and materials are ordered, how administrative processes work and how deliveries in and out of the company are organised, to ensure that each minor management system was effective. When ordering metals for example, certain grades and alloy contents would be required. Each batch of metal would be issued with a certificate of authenticity and this could be asked for under **ISO 9000/2000** checks to ensure quality of materials.

**ISO 9002** is concerned with quality standards in manufacturing and promotes initiatives such as RFT (right first time), which aims to ensure that all controls are built into the manufacturing process, to produce 'fool-proofing', eliminating problems as they occur, rather than having to deal with them after the product is completed.

**OHSAS 18001** is the Occupational Health and Safety at Work Standard and it is a legal requirement in many countries that this regulation is put in place. The point of **OHSAS 18001** is to identify elements in businesses that impact on health and safety and to produce objectives for improvement that will eliminate or minimise risks at work to employees.

This management system would deal with:

- Risk assessment
- Training and competency of workers
- Engineering safety of equipment and processes
- Safety of working areas
- Record keeping of daily inspections of machinery

**ISO 14000** deals with Environmental Standards, ensuring that companies comply with legislation, try to reduce costs and improve efficiency. Under ISO 14000, companies should:

1. Actively pursue 'green' policies such as recycling
2. Persuade suppliers not to use mixed packaging, which is hard to separate
3. Use cardboard rather than polystyrene (more recyclable).

My product would need to conform to electronic/electrical standards to ensure EMC (electro Magnetic Compatibility) and to safeguard quality of soldering and component integrity.

These requirements would be taken care of by:

- **BABT** – British Approvals Board for Telecommunications
- **BEAB** – British Electrical Approvals Board
- **IPC 610A** – standards set by international approvals body

## Overall performance for assessment criteria (d)

### *Planning for production.*

David has produced full and detailed evidence of planning for production for the engineered product. A realistic time plan, a sequence of assembly operations, a very detailed cutting list and a plan for the commercial batch production of PCBs are offered as evidence of planning effectively. Information is detailed and focused on the candidate's product; there are no general or ambiguous statements and none are retrospective.

Quality control checks are highlighted on the 'sequence of operations' sheet and on the 'PCB production' sheet and costs are discussed and calculated in consultation with the 'client expert' on a commercial prototype basis.

Timings for processes and assembly are realistic and workable, proof of which is that the product was complete and operational within the time allowed for manufacture. All aspects of planning produced by the candidate rightly focus only on the stages of product manufacture and not on the whole design and make process.

David has produced a clear production plan, made up of several elements with achievable deadlines and has used effective time management and resources appropriate to the scale of production to complete product manufacture within the set deadlines.

Relevant regulations and standards are presented and discussed by David relative to the product in hand. Examples of why and where each standard would be used illustrate a good understanding and grasp of each example given.

David has explained and justified the selection of regulations and standards relevant to the product and explained and justified their role during its manufacture.

The evidence presented in this assessment criterion is appropriate to the requirements of mark band 3.

Exemplar student response for assessment criteria (e)

Prototype manufacture.

**PRODUCTION PHOTOGRAPHS**

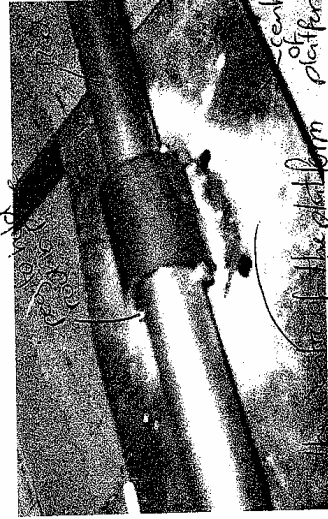
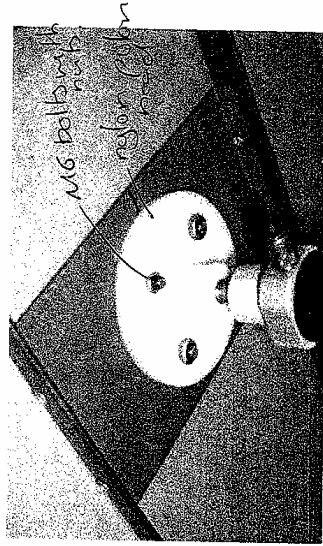
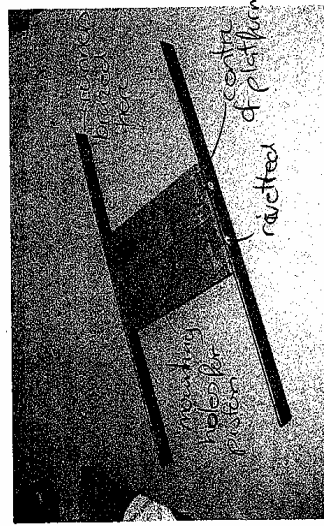
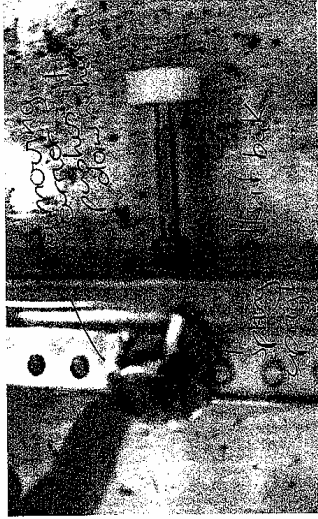
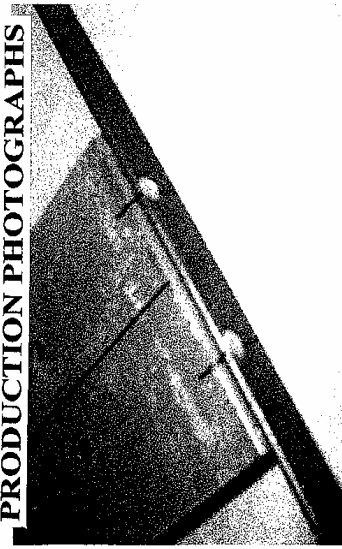



## PRODUCTION PHOTOGRAPHS

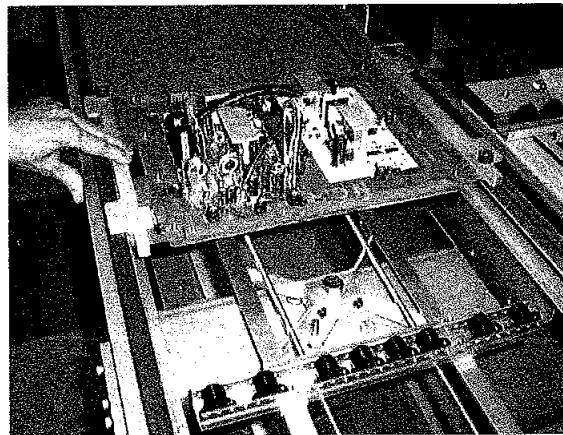
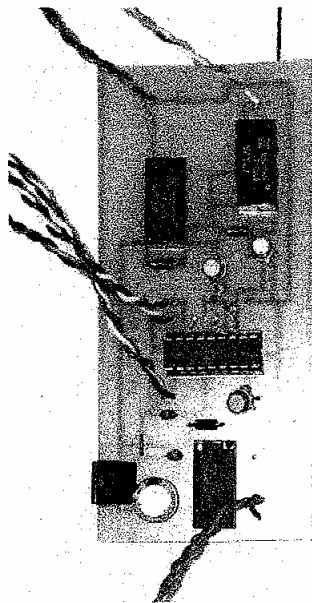
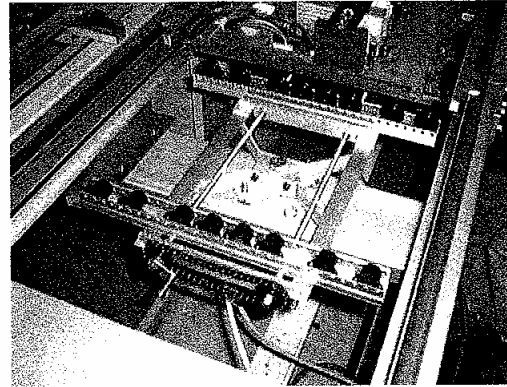
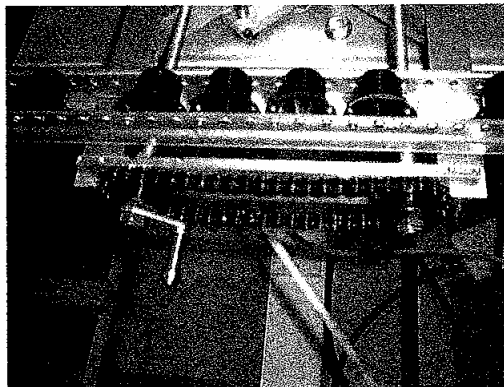
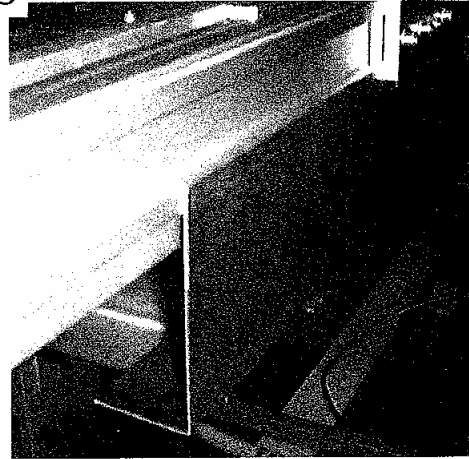
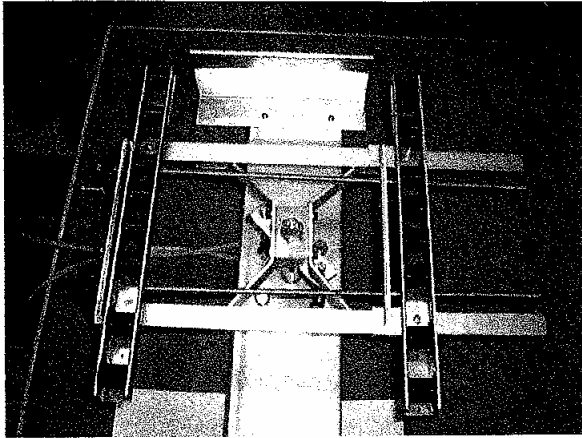

These photographs show some of the stages in the assembly and manufacture of my prototype. I was able to use some ready made parts, which would have been impossible for me to make otherwise.

The electronic circuit was straightforward and worked first time, as did the pneumatic circuitry.

The materials I worked with to make the body of the carrier were fairly easy to fabricate into parts, but I had to make jigs to ensure repeatability where more than one part was the same .

## TESTING/EVALUATION



The awkward repetitive motion performed by the workers at LITEON, leading to injury and discomfort

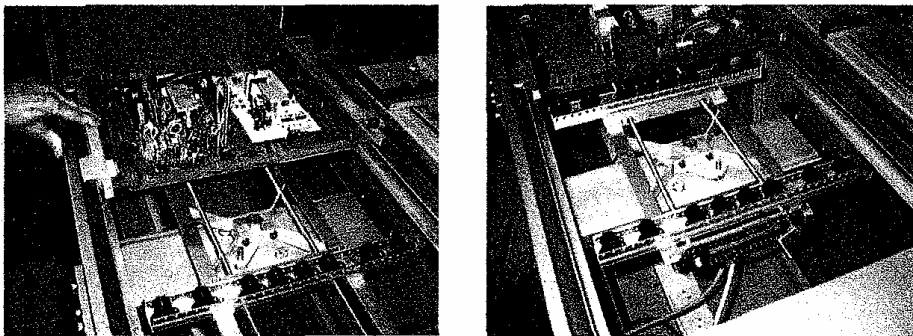

Here the product carrier is pushed onto the new lift, which is lowered, placing the carrier onto the production line. This way, the workers do not need to lift and turn and working is much more comfortable.

Two leadscrews were used rather than one as it is expensive to produce the longer rod. Leadscrews were bought-in items.

These were stock-items that Life On use in other applications

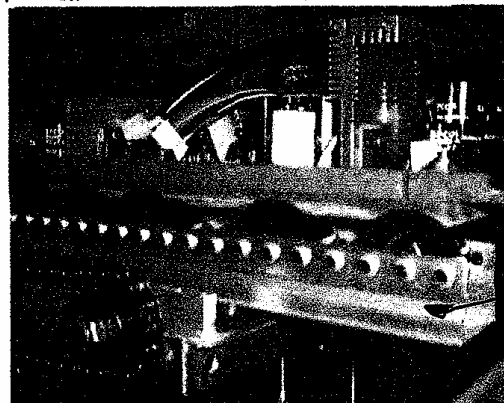
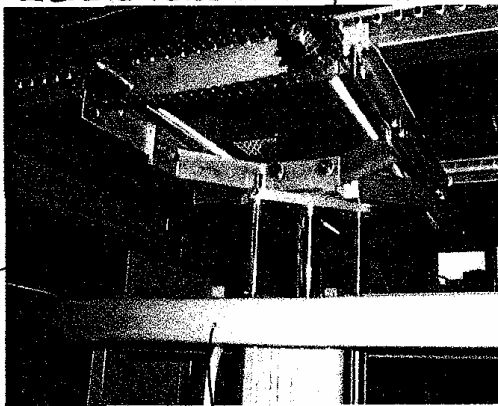

The specification points I was unable to meet were 13 and 14. It is really difficult to modify the design to suit other applications. Also, the design is very heavy, so lower density materials could have been used and still retained enough robustness and strength to have done the job efficiently.

## Overall performance for assessment criteria (e)

### *Prototype manufacture.*

Photographic evidence in the 'Production photographs' and 'Testing/evaluation' sections of the design folder show a well made product that is appropriate to the level of response expected at A2 level in this subject. The series of photographs shown supports the candidate's high quality making competencies and illustrates the range of skills and processes involved in the product manufacture.

A good understanding of appropriate materials and the suitability of their properties to the product are evident through the photographic images presented, the detailed cutting list presented under 'Planning' and the 'Materials selection' sheet which uses researched scientific data on materials properties to justify their selection.

Evidence of a range of processes being used and high-level skills in their application is well illustrated through the series of informative photographs that document progress in making, assembly and testing. Photographs also reinforce the quality of making as the product is evaluated against the specification and found to be a success.

It is obvious that a single or limited number of images of a final product outcome are unlikely to support high reward in this assessment criterion and it is important to ensure that photographic details convey levels of difficulty and complexity of construction. A series of images covering the manufacturing progress of a product is the ideal way to justify the marks awarded in this assessment category.

David has shown a clear understanding of a wide range of materials, components and processes and has demonstrated demanding and high-level making skills that show precision and attention to detail and has demonstrated high levels of safety awareness of safe working practices (see witness statement).

The photographic evidence presented, illustrating the candidate's high level making skills in manufacturing a fully functional prototype that has been made with precision, matching the final design proposal and the selection of materials based on scientific/mathematical data supports the award for mark band 3.

## Exemplar student response for assessment criteria (f)

*Testing, evaluation and suggestions for modifications to improve the performance of the engineered product.*

### TESTING/EVALUATION

#### Testing Of Final Prototype:

Once I have finished the construction of my prototype I will need to test the design in a similar way to my initial tests. Only with everything linked together. Problems that could occur are things such as the solenoids not switching over snappily enough it the output voltage from my circuit is not sufficient. I will run my device from a power pack and a compressor. On top of performing the same tests as previously I will need to test the motion of the platform. This will be done by extending the platform repeatedly to test how smooth the movement is and by testing the vertical motion of the device loaded to see if there are any changes in the velocity of ascent. The first step will be to test the circuit pins then rig everything up together and perform the complete tests.

#### Tests:

1. Voltage levels across the circuit and checking for low bounce and snappy amplifying actions.
2. Check the function of all of the various program permutations.
3. Test the function of the whole device when rigged up completely -  
smooth vertical motion under the load of the platform;  
smooth, constant vertical motion when the platform is heavily loaded;  
smooth horizontal extension of the platform;  
stability of platform under load.

#### Results:

1. The voltage levels and action across the circuit is very similar to that found in the breadboard prototype. There is no problem with the function of the circuit.
2. The programme also function equally well.
3.
  - (i) The device works well with no load, the solenoid valves click across snappily and generally the device performs well. A minor problem however is that the piston arm tends to swing round until the railings stop against the trough. No short-term solution but when fitted on the conveyor the platform is more closely surrounded by 'walls' so will swing less. This movement could cause the carrier to be placed incorrectly (not straight) on the conveyor.
  - (ii) After calibration of flow restrictors the platform moves smoothly and at a speed that has very little chance of dislodging components.
  - (iii) The device responds no differently under loads of up to 10kg (testing limit) and there is no chance of any carrier with product weighing so much. The current heaviest in the LiteOn plant is little over 2.5kg.
  - (iv) Initially when tested in this respect the legs of the railing caught inside the runners and caused the railings to stop moving. The legs then had to be pushed straight again to start moving (banged would be more accurate). The solution to this problem is that the legs be very tightly bolted into place and locked with a second bolt so that they are completely rigid. After this modification the railings ran extremely smoothly. The only small criticism being the small pitch of the screw thread, requiring a great many turns for a small gain in horizontal distance.
  - (v) The Platform is very stable even under large loads and is capable of supporting weights much greater than is necessary easily, and still give a smooth motion.

## TESTING / EVALUATION

These photographs show evidence of testing as the prototype is being built.

The image on the right shows the PIC being tested on a commercial test-board to check that the program is operating correctly. Inputs and outputs can be simulated by onboard switches and LEDs. If the program is OK, it means that any electronic problems can be traced to the PCB circuit

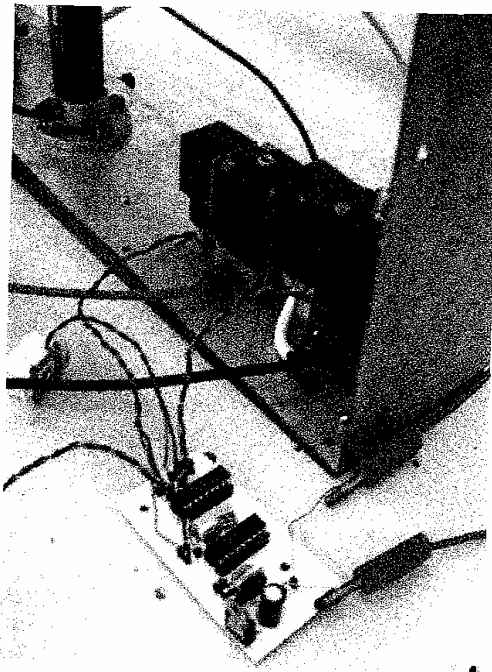
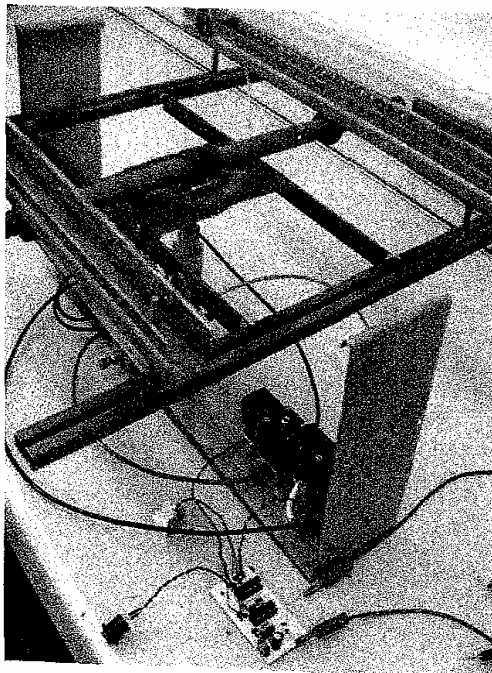
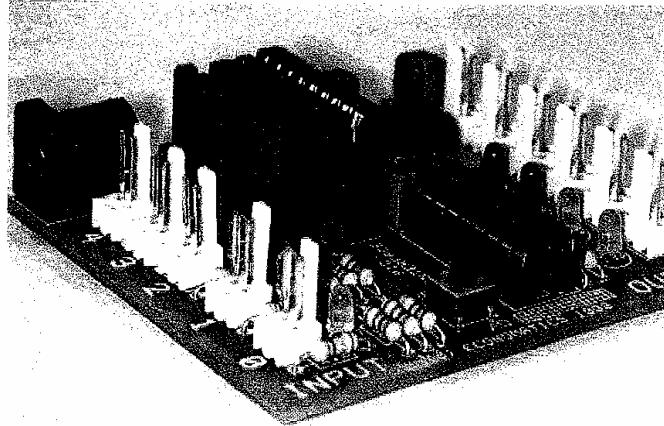

The photographs above show the electronics being tested. I am operating the magnetic switches and the PIC is responding by switching the pneumatic solenoid valves, which are being driven by an octal Darlington driver IC.

The photograph on the right shows the whole prototype rig ready for installation with everything operating properly – to my great relief.

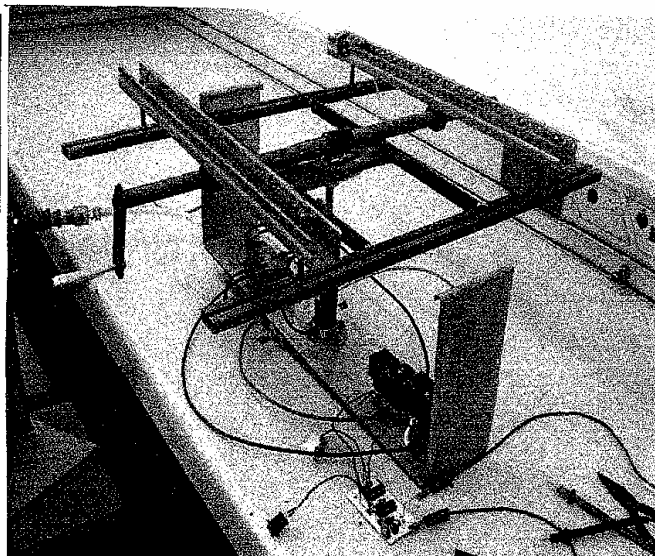

## TESTING/EVALUATION

### Project Brief:

*“Design and build a prototype device which will take product carriers off the end of the manufacturing cells and load them onto the conveyor system without the need for production operatives to lift or twist”*

The final working prototype fulfils this brief. It successfully accepts and lowers the carriers onto the production line, and will therefore reduce the amount of strenuous, repetitive work done by the final worker on the production line. The adjustment of the platform to accept various carrier sizes is simple, and the device can easily be removed from the production line and taken to another area of the factory. The airflow system runs directly underneath the conveyor system so it can be plugged into a compressed air supply easily.

The LiteOn engineers working with me have written an evaluation of the device:

*LiteOn identified a potential problem within part of its manufacturing process which could cause repetitive strain injury (RSI) and quality defects on the product. Production operators have to lift heavy product carriers from the end of the production line onto a conveyor belt. They may lift over 300 carriers a day. In doing so, they risk strain from lifting and can also knock the product and dislodge components.*

*This project has identified and prototyped a fully automated system for transferring the product to the conveyor which eliminated manual activity (and therefore potential RSI risk), and reduces the risk of components being dislodged in transit. The solution has also improved morale on the shop floor through the elimination of an unpopular and strenuous task. The system will now be adapted and installed in all the other manufacturing cells within the business.*

With the design installed on the production line then the company will potentially gain a great advantage in efficiency – when components are dislodged before soldering, time must be spent re-soldering by hand, which is expensive. Increased morale on the shop floor could also increase the efficiency with which the operatives work at.

With the adapted prototype installed in the LiteOn factory I talked to a production line operative to judge the success of the project and if it was an improvement on the previous system:

- 1) Do you experience any pain during or after work because of the repetitive nature of the job?

*I occasionally suffer from a sore back after work hours*

- 2) Are you glad to see an improvement in this system?

*Yes, definitely. It will make working much more comfortable and easier. Working at the end of the production line is fun now and people want to work here as a novelty, as opposed to hating it.*

## TESTING/EVALUATION

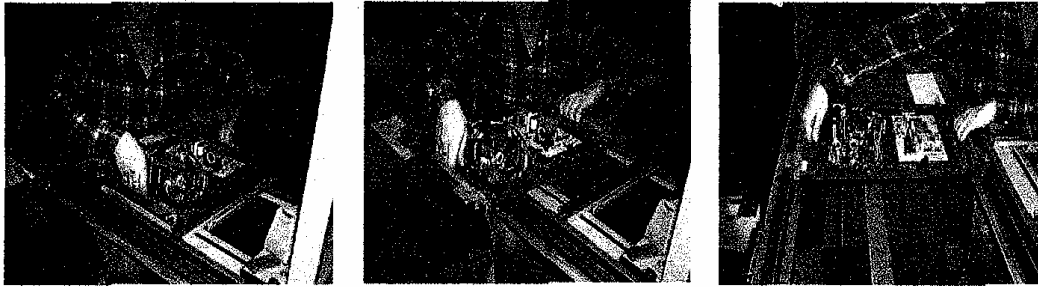

The awkward repetitive motion performed by the workers at LITEON, leading to injury and discomfort

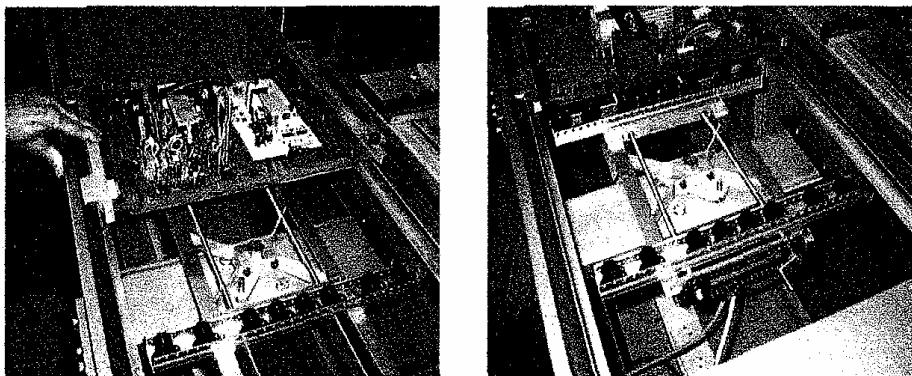

Here the product carrier is pushed onto the new lift, which is lowered, placing the carrier onto the production line. This way, the workers do not need to lift and turn and working is much more comfortable.

Two leadscrews were used rather than one as it is expensive to produce the longer rod. Leadscrews were bought-in items.

These were stock-items that Life On use in other applications

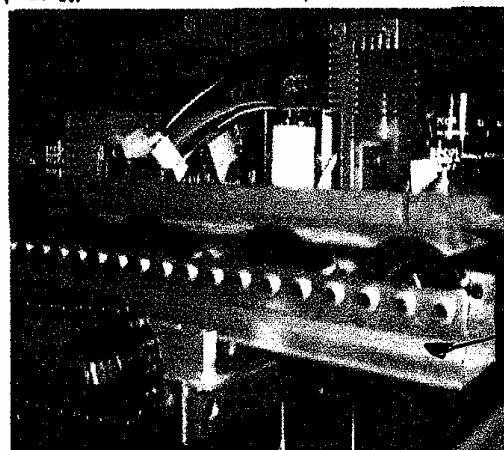
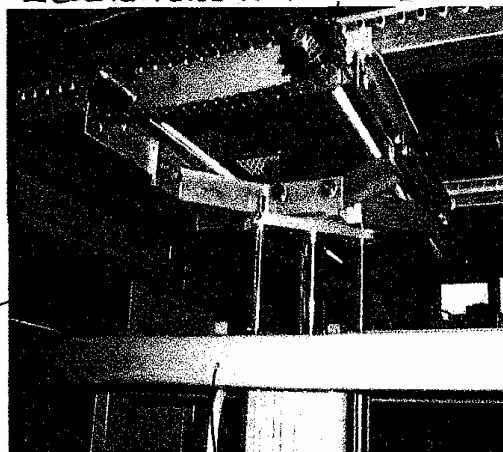

The specification points I was unable to meet were 13 and 14. It is really difficult to modify the design to suit other applications. Also, the design is very heavy, so lower density materials could have been used and still retained enough robustness and strength to have done the job efficiently.

## MODIFICATIONS

When I was testing the prototype, I realised that there was a danger that operatives could trap their fingers in the gap between the platform and the conveyor belt mounting as the lift rises. This could cause a serious problem because it makes the company vulnerable to liable action. The best solution to this problem I think is with a combination of two approaches. The first is to move the last operative on the production line away (out of reach) from the conveyor system. The product carrier can then be moved onto the platform using a small motor driven conveyor belt at the end of the production line that would be turned on constantly. The second part of this solution would be to encase the device completely in a shell made from some easily available material. The device would also be made wider so that it fitted very snugly with the edge of the gap it sits in. This would mean that fingers or body parts could not fit in the gap so could not become trapped and damaged.

A second modification could be to centralise the control of devices on a single conveyor belt (this would always be two in the local plant unless production were significantly stepped up). A single 28 PIC could be used to control the two devices.

A second potential problem with the current device and control circuit is that the speed of the conveyor belt is occasionally altered. With the current static sensors, the sensors would have to be placed a greater distance away so that the platform could avoid the fastest-moving carriers when the conveyor is moving quickly. But in this case, when the conveyor is moving slowly, the platform would go down far too early and production efficiency could be compromised by operatives being delayed waiting for the platform to re-raise. A solution to this problem is to have the static sensor at the place for the fastest carrier all the time and then to progressively delay the output as the speed is reduced. This would need to be done manually to some extent but the speed would only be rarely changed and calibration would not be difficult. The following circuit shows how this modification could be added to the current design.

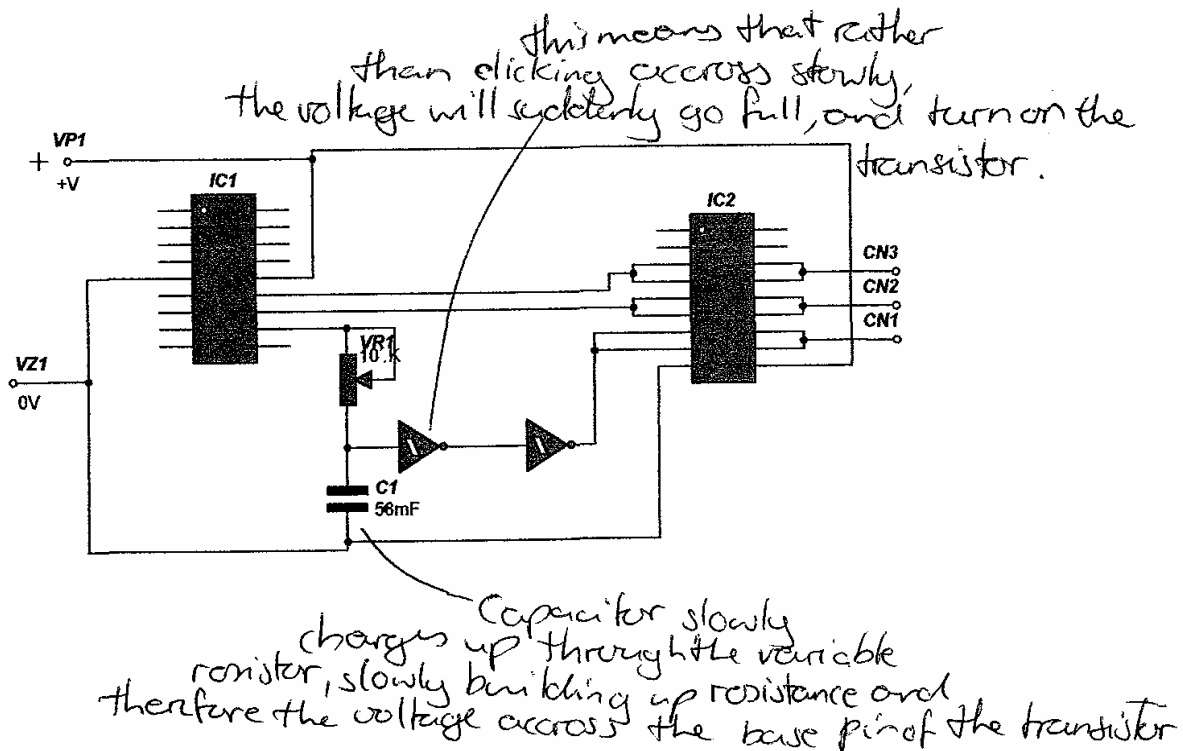



## MODIFICATIONS

### CALCULATING the CAPACITOR SIZE needed.

Supply voltage from PIC output = 5V

Voltage needed across capacitor = 1.2V

Maximum delay in lowering lift should be 5secs.

$$V_{\text{final}} = V_{\text{initial}} \times \left(1 - e^{-\frac{t}{RC}}\right)$$

Where  $t$  = delay  
 $RC$  = Time constant  
 $V_{\text{final}} = 1.2V$   
 $V_{\text{initial}} = 5V$

Total resistance in potential divider at this point

$$\text{Resistor Value} = \frac{10k}{\text{Ref Cap} + \text{Resistor}} \times 5V = 3.8$$

Supply  
V across 10k Resistor

$$\begin{aligned} \text{Ref Cap} + \text{Resistor} &= \frac{10k + 5}{3.8} = 13.158k \\ &= 3.2k \end{aligned}$$

$$RC = 13.2k \times \text{Capacitance}$$

$$1.2 = 5 \left(1 - e^{-\frac{5}{RC}}\right)$$
$$\ln\left(\frac{1.2}{5} + 1\right) = \frac{-5}{13.2k \times C}$$

$$\ln\left(1 - \frac{1.2}{5}\right) = \frac{1}{13.2k \times C} = \frac{1}{13.2k \times C} = 18.22$$

$$C = 5.77 \times 10^{-4} F = \underline{\underline{0.58 \mu F}}$$

## Overall performance for assessment criteria (f)

*Testing, evaluation and suggestions for modifications to improve the performance of the engineered product.*

The product has been completed to a high quality level within the time frame predicted in the work plan and consequently has been able to be tested and evaluated effectively. David has objectively tested the completed prototype against measurable points of specification and has shown photographs of testing in progress. Field trial tests are described and third party responses in the form of company representatives have been recorded for use in the final evaluation.

Problems in construction and performance have been identified through testing and these are further developed during the summative evaluation, where comparison and discussion of product performance is set against the points of specification.

Suggestions for modifications that would improve the performance and quality of the product are made and these arise from problems recognised in testing and evaluation. Testing, evaluation and suggested modifications are shown to be linked together and are underpinned by each other in the work presented in this section by the candidate. Technical suggestions for modifications are developed using scientific/mathematical data to enhance the future performance of the product.

Photographic images and clear sketches are used skilfully throughout this assessment section to explain and illustrate points under consideration.

David has presented evidence of the effective use of testing and evaluation to establish the success of the final outcome and to ensure its fitness for purpose. Realistic suggestions for appropriate future improvements are made in the form of technical modifications that are underpinned by scientific and mathematical application.

The evidence presented in this assessment criterion meets the requirements of mark band 3.

# Appendices

---

Appendix A: Glossary of key terms

Appendix B: Edexcel GCE in Engineering – Witness Statement

Appendix C: Edexcel GCE in Engineering – Unit 2 Mark Record Sheet

Appendix D: Edexcel GCE in Engineering – Unit 3 Mark Record Sheet

Appendix E: Edexcel GCE in Engineering – Unit 4 Mark Record Sheet

Appendix F: Edexcel GCE in Engineering – Unit 5 Mark Record Sheet

Appendix G: Edexcel GCE in Engineering – Unit 6 Mark Record Sheet

Appendix H: Qualification tracking sheet

Appendix I: A guide for students on report writing

Appendix J: Induction session for students

Appendix K: Case studies

Appendix L: Useful strategies for students when tackling the internal units



# Appendix A: Glossary of key terms

## Unit 1

<b>Alloys</b>	A 'mixture' containing at least two different metals. Properties of the alloy are different from the properties of either constituent metal.
<b>Ceramics</b>	Materials made from clays that have been heat-treated at high temperatures.
<b>Composites</b>	Materials containing more than one material usually one in the form of a grid or lattice (steel reinforcing rods or glass cloth) to provide strength in tension, and another as a filler between the spaces (concrete or polyester resin) to provide strength in compression.
<b>Degradation</b>	A word to describe a reduction in a property perhaps caused by oxidation.
<b>Elastomers</b>	Materials which stretch, eg rubber.
<b>Fatigue</b>	The reduction in strength due to repeated bending or stressing.
<b>Ferrous</b>	Metals containing iron.
<b>Mechanical properties</b>	Properties that define the physical characteristics of a material, eg its strength, resistance to wear.
<b>New/smart materials</b>	Materials produced in perhaps the last 20 or 30 years. They have different properties to conventional materials, eg heat shrink sleeving – big enough to feed wires through to form a wiring loom – but when heated shrinks back to its original size and holds the wires firmly together.
<b>Non-ferrous</b>	Not containing iron, and therefore usually non-magnetic.
<b>Oxidisation</b>	The reaction of a material exposed to oxygen, usually seen as a surface discolouration that leads to deteriorating properties.
<b>Structure</b>	The way atoms are connected together to make up the material, eg in long chains, or as interconnected crystals.
<b>Table of properties</b>	Tabulated data on properties of different materials, or of different properties of a specific material. Usually found in reference books and manufacturers' data sheets. Could refer to a particular material, eg a specific aluminium alloy or a component, eg a particular transistor.
<b>Thermal joining</b>	Joining components of similar materials using heat, eg soldering.
<b>Thermal properties</b>	Properties that are dependent on temperature, such as ability to transmit heat, or to prevent heat flow (insulation).
<b>Thermoplastics</b>	A polymer that softens and liquefies when heated. Can be shaped by heating, eg acrylic sheet can be bent when heated to about 200 degrees Celsius.
<b>Thermosetting</b>	A polymer that undergoes a chemical reaction when used to make a component. Heat generated during this reaction (curing). Cannot be re-melted and reused after curing.

## Unit 2 and Unit 5

<b>Automation</b>	Techniques used to make a sequence of activities occur without human intervention.
<b>Codes of practice</b>	Books describing ways of working which meet accepted industry standards. Descriptions of how a job should be done safely, so that the product is safe.
<b>Communications</b>	In this context it refers to techniques and systems which facilitate communication, eg mobile phones, email, satellite communication.
<b>Electromagnetic compatibility</b>	Requirement based in law to ensure products can work together without interfering with each other.
<b>Engineering disciplines</b>	Branches of engineering, eg electronic, aerospace.
<b>Hazards</b>	Something that is likely to cause injury. Could be a box left where it can be tripped over, or a cutting operation where someone could be hurt.
<b>Precautions</b>	Actions taken to reduce the likelihood of a hazard causing an injury. Could be a guard on a machine.
<b>Procedure</b>	A defined way to carry out a particular task. Internal company document.
<b>Risks</b>	The likelihood of a hazard causing someone to be injured.
<b>Risk assessments</b>	Process of defining level of risk, and minimising risks due to specified hazards. See Health and Safety Executive information.
<b>Schematic diagrams</b>	A drawing which shows the scheme of things. Usually refers to a diagram showing how a system works, used for fault finding, as opposed to a layout diagram which shows where the wires physically run.
<b>Standards</b>	A description of a service or product performance, eg the set of standards defining sizes and tolerances for metric nuts and bolts. Adherence to the standard ensures that all metric bolts of a given size fit all metric nuts of the same metric size - irrespective of who made them and when they were made.
<b>Systems</b>	An interconnection of components or functional elements, eg into a circuit. Could be electrical, mechanical or hydraulic.

## Unit 3 and Unit 6

<b>BS8888:2002</b>	The British Standard for basic drawing conventions.
<b>Electronic systems</b>	Using electronic components, perhaps a control or monitoring system.
<b>Energy systems</b>	An engineering system which uses or converts energy.
<b>Engineering drawings and diagrams</b>	Diagrams created to set standards which describe and explain engineering systems. Use of internationally recognised standards ensures that engineers worldwide can all understand them.
<b>Ergonomics</b>	The interface between the human and the machine. Making machines easy and comfortable to use.
<b>Final design solution</b>	The final initial idea fully developed. It will consist of a set of engineering drawings, with supplementary information.
<b>First and third angle projection</b>	Two different conventions for laying out views of a component as in plan view, side elevation and end elevation – see BS 8888.
<b>Fluidic</b>	Using pneumatic or hydraulic systems to transmit energy.
<b>Flow diagrams</b>	Diagrams showing how fluids flow around a system. A block diagram showing how a system works.
<b>Freehand sketching</b>	Producing isometric and oblique drawings as a way of describing initial ideas quickly.
<b>Hidden detail</b>	A conventional way of depicting details that cannot be seen from the surface of the object as it is drawn.
<b>Isometric and oblique projections</b>	A conventional way of drawing 3 dimensional representations of components and assemblies. Specific to engineering. Engineers do not use perspective drawing.
<b>Prototype</b>	A first attempt at a working model of a design.
<b>Quality</b>	Fitness for purpose. Relationship between functional requirements and performance. If it is supposed to be 10mm long – within 0.1 mm, then is it actually bigger than 9.9mm and smaller than 10.1mm? Not to be confused with the non-engineering use of the word ‘quality’ as in ‘high quality’.
<b>Rotary systems</b>	Systems involving rotating components such as motors, gears and shafts.
<b>Scales</b>	Every drawing should have a scale or state ‘not to scale’.
<b>Schematic diagrams</b>	A diagram showing the function of a circuit.
<b>Scientific and mathematical principles</b>	The theory and calculations that convert initial ideas into a workable design solution. It might involve calculations to determine the values of resistors in a circuit.
<b>Technical information</b>	Scientific data, values, component identifiers, data sheets.
<b>Technical specification</b>	A version of the client brief which sets out the requirements in technical terms. Sets out sizes, tolerances etc.

## Unit 4

<b>Analogue to digital converter</b>	Converting real world signals such as the level of water in a river into a digital code that can be processed in a computer.
<b>Black box</b>	Looking at the input and output and ignoring what is inside. Taking a 'black box' approach.
<b>Earthing</b>	Connecting non-live parts of circuits and casings to zero voltage. The earth itself is often considered to be at zero voltage. Carried out by connecting to an earth rod, or an earth conductor supplied with the electricity supply.
<b>Hydraulics</b>	Driven by oil or some other non-compressible medium.
<b>Hysteresis</b>	A lag or offset in a system.
<b>Marking out</b>	Making marks on the surface of a blank before removing excess material. Marking where waste material is to be removed. Note that it is unusual in engineering to actually make any marks on the surface of a blank. The measurements are usually carried out on a jig and the component inserted into the jig for processing. This is used not only to make batches of products but also when making one-off items. It avoids damaging the surface of the final component.
<b>Microprocessor</b>	Used as the 'brains' of a computer or control system. Usually takes the form of an integrated circuit.
<b>Over current protection</b>	Equipment designed to limit the current in a circuit. Prevents damage to the cables, and the circuit.
<b>Pneumatics</b>	Driven by air or vacuum.
<b>Programmable Logic Controller</b>	A pre-packaged computer system used for industrial control. Might be used to manage a small bottling plant, or some automated process. Designed to be programmed using relay control techniques (ladder logic), but increasingly using visual basic. Input and output connections pre-installed.
<b>Residual current detector</b>	Detects when there is energy lost in a circuit. If the current going out is not the same as the current returning it turns the circuit off. Acts quickly. Protects against electric shock, used for household, gardens etc.
<b>Sampling rate</b>	How often the analogue to digital converter measures a parameter, eg the depth of water.
<b>Sensors</b>	A device to make a measurement such as a pressure sensor to monitor oil pressure.
<b>Transducers</b>	Device to convert energy to another form.



## Appendix B: Edexcel GCE in Engineering – Witness Statement

Student name:

Unit title:

Student number:

### Activity context

*Outline of the activity and its purpose.*

*The assessor or the student, prior to observation, may write this.*

### Assessment evidence

*Refer to the assessment grids produced from the specification.*

### Observation notes

*Specific comments on student performance that demonstrate achievement of the assessment evidence.*

Assessor name:

Assessor signature:

Date:



## Appendix C: Edexcel GCE in Engineering – Unit 2 Mark Record Sheet

Centre no:	Centre name:	Internal moderator name:
Candidate no:	Candidate name:	Resubmission of work
Series number:		
		All/mostly amended
		Some amendments
		No amendments

Unit 2: The Role of the Engineer						
Assessment evidence	Annotation and page number	Mark band			Centre mark	Edexcel use only
		1	2	3		
(a)		0-4	5-6	7-8		
(b)		0-6	7-9	10-12		
(c)		0-4	5-6	7-8		
(d)		0-4	5-6	7-8		
(e)		0-8	9-12	13-16		
(f)		0-4	5-6	7-8		
<b>Final total</b>						

<b>Edexcel moderator use only</b>	Name:
AA number:	Signature:



## Appendix D: Edexcel GCE in Engineering – Unit 3 Mark Record Sheet

Centre no:	Centre name:	Internal moderator name:
Candidate no:	Candidate name:	Resubmission of work All/mostly amended Some amendments No amendments
Series number:		

Unit 3: Principle of Design, Planning and Prototyping						
Assessment evidence	Annotation and page number	Mark band			Centre mark	Edexcel use only
		1	2	3		
(a)		0-4	5-6	7-8		
(b)		0-4	5-6	7-8		
(c)		0-8	9-12	13-16		
(d)		0-10	11-15	16-20		
(e)		0-4	5-6	7-8		
		<b>Final total</b>				

<b>Edexcel moderator use only</b>	
AA number:	Name: Signature:



## Appendix E: Edexcel GCE in Engineering – Unit 4 Mark Record Sheet

Centre no:

Centre name:

Internal moderator name:

Candidate no:

Candidate name:

Series number:

Unit 4: Applied Engineering Systems							Edexcel use only
Assessment evidence	Annotation and page number	Mark band			Centre mark		
		1	2	3			
(a)		0-8	9-12	13-16			
(b)		0-2	3-4	5-6			
(c)		0-4	5-7	8-10			
(d)		0-2	3-4	5-6			
(e)		0-9	10-14	15-18			
(f)		0-2	3	4			
		<b>Final total</b>					

**Edexcel moderator use only**

AA number:

Name:

Signature:





## Appendix F: Edexcel GCE in Engineering – Unit 5 Mark Record Sheet

Centre no:	Centre name:	Internal moderator name:
Candidate no:	Candidate name:	Resubmission of work
Series number:		
		All/mostly amended
		Some amendments
		No amendments

Unit 5: The Engineering Environment						
Assessment evidence	Annotation and page number	Mark band			Centre mark	Edexcel use only
		1	2	3		
(a)		0-4	5-6	7-8		
(b)		0-4	5-6	7-8		
(c)		0-6	7-9	10-12		
(d)		0-4	5-6	7-8		
(e)		0-6	7-9	10-12		
(f)		0-6	7-9	10-12		
		<b>Final total</b>				

<b>Edexcel moderator use only</b>	
AA number:	Name:
Signature:	



## Appendix G: Edexcel GCE in Engineering – Unit 6 Mark Record Sheet

Centre no:	Centre name:	Internal moderator name:	
Candidate no:	Candidate name:	Resubmission of work	All/mostly amended
Series number:			Some amendments
			No amendments

Unit 6: Applied Design, Planning and Prototyping						
Assessment evidence	Annotation and page number	Mark band			Centre mark	Edexcel use only
		1	2	3		
(a)		0-4	5-6	7-8		
(b)		0-8	9-12	13-16		
(c)		0-2	3-4	5-6		
(d)		0-4	5-6	7-8		
(e)		0-8	9-12	13-16		
(f)		0-2	3-4	5-6		
<b>Final total</b>						

<b>Edexcel moderator use only</b>	
AA number:	Name:
Signature:	







# Appendix I: A guide for students on report writing

## What is a report?

A report is a conventional method of presenting precise information. A report may be used to convey an assessment of any situation or the results from qualitative and/or quantitative data analysis. A report has clearly stated aims. It is tightly focused on the subject of the investigation. A really effective report will also be compelling and stimulating to read.

## Producing a report

To help you to produce a report, four stages in the process have been identified for you to follow. This may help you to tackle key issues and understand the task set. The four stages are:

- A preparation
- B planning
- C writing
- D pre-submission editing.

### A Preparation

The first stage is to make a choice from the list of titles – in particular do you want to do some primary research? Choose a title that you are interested in.

The time spent at this stage of producing the report is vital. Careful preparation is an investment. It allows you to make the best use of time available. During this period you should decide **what** you are writing and **why**, before resolving **how** to write your report.

Establish the broad focus of your report first with reference to the specification and assessment objectives and then with reference to the generalisation. Undertake some individual background reading using the suggested bibliography. Use a search engine to look for more possibilities. This enables you to **define the subject and your aims more precisely**. If you are going to do some primary data collection it is best to make your appointments for people you need to see, and do an initial survey at this stage.

When you have completed your reading and feasibility study, review the key issues and research methods that will be used within your report. Make a note of them.

### B Planning

Planning is essential. It saves time and promotes clarity in collecting the information you require in organising the material and in writing the report.

You will find it easier if you break the whole process down into a number of distinct tasks:

- i data collection and analysis can be broken down either according to the source or the subsection of the report
- ii similarly the writing process can be broken down – the writing of text into subsections, and the presentation into graphs and tables.

You will also be faced with a number of questions:

- 1 what evidence is needed to meet the overall objective of the report?
- 2 where is that evidence?
- 3 how much evidence should be collected?
- 4 how should the evidence be analysed?
- 5 how should the evidence and the analysis be ordered for writing the report?

Attempting to deal with all these factors in a chaotic way leads to confusion and wasted effort. Therefore, after 'preparation' you should begin to plan the data collection, analysis and writing process. **Good organisation is the key to success.**

Using the following sequence may help you to plan and to determine the method for writing your report:

- a identify the sources of evidence (data and/or literature) and look for a range of views on the issue
- b decide what is the most appropriate and relevant evidence to collect – **be precise in this, understand the evidence**
- c decide how you will present your findings including the order in which they will be used to create a structure to the report – **the plan**
- d identify likely figures – maps, tables diagrams and think how you can use them
- e decide on the order of priority of each of the tasks
- f draw up a realistic timetable for the completion of each task, including writing the draft of the report.

## C The writing process

There are three main factors to consider at this stage to give your report a sound framework, clear style and an attractive appearance:

- 1 structure
- 2 language
- 3 presentation.

### 1 Structure

You need to give form and shape to your report. A basic structure helps the reader to digest the report. It also helps you to write and organise your material logically.

A structure implies the assessment criteria, but your report should have the following:

- |                |   |  |
|----------------|---|--|
| The main body. | { | <ul style="list-style-type: none"><li>* report cover sheet, title page and contents</li><li>* executive summary/abstract (on front cover)</li><li>* introduction and definition of the question or issue</li><li>* sources of research information used, methods of collection and analysis and their limitations</li><li>* analysis and interpretation</li><li>* evaluation and conclusion</li><li>* bibliography and appendices.</li></ul> |
|----------------|---|--|

First concentrate on writing the body of the report. This is the introduction, the findings, and the conclusions. Then deal with the other sections.



The following order for writing is suggested.

The bulk of the report.

**a Analysis and interpretation**

This is the section in which you present your findings. When you are writing this section all of your material should have been sorted, selected and arranged in note form. This section includes:

- i the results of your analysis
- ii your interpretation of those results.

This section forms the basis for your conclusions. You should help the reader by ending each separate section with its own conclusion.

Just a couple of sentences here – perhaps 100 words. Full details could be in an appendix.

**b Methods**

In this section you should discuss:

- i the sources of evidence you have used and then possible bias
- ii how you have collected and analysed the evidence
- iii the limitations of the sources and methods of collection and analysis.

**c Conclusions**

This section is a summary of all the major findings made at stages throughout the report. No new evidence should appear here. The conclusion considers the evidence presented in the main body, draws out the implications and brings it to one overall conclusion or an ordered series of final conclusions.

**d Introduction**

After having written your findings and conclusions you now know clearly what you want to introduce. The introduction is where you acquaint the reader with the purpose of the report and guide them through the structure of your report.

**e Appendices**

This section is set aside for supplementary evidence not essential to the main findings, but which provides useful back-up support for your main arguments, eg a transcript of an interview or analysis of a complex set of statistics.

**f Contents**

All the sections of the report should be listed in sequence with page references.

**g Bibliography**

This section covers the books and other sources which have been used in your research. It must include every reference mentioned in the text and be presented correctly.

**h Title page**

This should include the title, which indicates the central theme of the report. It should also include the student's name and the date of completion of the report.

**i Executive summary or abstract**

This is a very important part of the report. It should be the last thing you write. You need to read through your report and develop a list of headlines. An executive summary outlines the key issues of a report.

Not included in word count.

Only 50 words not included in word count.

## 2 Language

First impressions count. It is unwise to put the reader off before they have even studied the report.

You are solely responsible for what you write and the words you choose to express your thoughts. Remember that although you might have an individual 'style' of expression this does not excuse poor English. Your style will not necessarily be immediately apparent to the reader, but poorly expressed English will be. Your sentences must be grammatically correct, well punctuated and words must be spelt accurately.

Poor writing regularly indicates muddled ideas. You do not really know what you are saying until you put it into words that another person can easily understand. Remember you are writing to communicate, not to perplex or impress. Avoid jargon. Focus on the specific purpose of the report. Every part of the report should relate to it and this will help keep the report concise and coherent.

Accuracy is vitally important so always be precise. Ensure that you are using the correct words. **Clarity is essential.** Do not write phrases or sentences that may have more than one meaning. To avoid this you must know precisely what you want to say. **Know the material you are trying to convey.**

Other important things to remember.

Keep sentences short and simple. Long complex sentences slow the reader down and confuse and impede understanding. The same applies to paragraphs.

Poor spelling automatically detracts from your work and will annoy the reader. Use a dictionary and you can also check the final document using the spell checker on the pc. (Remember, however, that this may well use American spellings and its dictionary may not include all the words you use in the report.)

## 3 Presentation

Your report must look good in addition to reading well. Adequate headings and numbering make it easier for the reader to comprehend what you are saying. This stage of report writing requires the same level of care that went into composing the text. Do not be afraid to use **bullet points** to present arguments.

The presentation of statistics is often more informative and eye-catching if they are shown visually: for example by using tables or pie charts.

Layout is important. This is the relationship between print and space on the page. This applies whether it is hand-written or word-processed. A crowded page with dense blocks of writing and little space looks unattractive and is off-putting.

Always ensure that there are:

- adequate margins
- either double or 1.5 spaced lines
- headings that stand out clearly from the page.

## D Pre-submission editing

It is important not only to read the draft through from start to finish before submission but also to edit and refine the report. This is easy when word processing.

As you read, mark the pages which will need attention later. Do not stop to deal with them now. You will need to get a feel of the overall structure and impact of the report first so your initial read through must be continuous. Put yourself in the reader's shoes and be highly critical of what you have written.

**Proof reading** is vitally important. Regardless of the time and effort put into writing the report, the required result will not be achieved without sufficient care devoted to proof reading. A poorly typed report, full of errors and inconsistencies in layout, has a damaging effect regardless of the quality of the content.

- a The report must be checked in great detail, for grammar and spelling errors.
- b Ask yourself whether you could have expressed yourself in a better way. If so, change the sentence or the paragraph.
- c Consider whether the structure of the main body of work is really the most suitable one to present your material, ideas and arguments.
- d Is each paragraph structured well? Make sure that every idea or piece of information has a separate paragraph.
- e Are all the references in the text included in the bibliography with full, formal details?
- f Does the report fulfil the stated aims and assessment objectives?
- g Is your argument watertight and easy to follow?
- h Does your conclusion make your argument all the more convincing?
- i Does your executive summary/abstract convey the key points of the report?
- j Finally, assess the layout and general appearance of the document.



# Appendix J: Induction session for students

## Introduction

The aim of this induction session is to introduce you to some of the words that you will commonly see within the GCE assessment criteria grids and within the activities that you are given. It is also a team-building exercise, as you will work with other members of your course to discuss results and produce a final answer chart, which you, as a team will discuss with your teacher.

## Task

- Work in pairs. Look at the following list of words (active verbs) and definitions.  
You are to decide which word goes with which definition – you are to pair/match them up.  
In the box beside a definition, place the word that you believe pairs up to that definition.  
The words are to be placed in a box only once and there is to be one word only chosen per box. The first definition has been completed for you and matched with the word ‘explain’.  
This is the only word to be placed in the word box.  
A dictionary definition help sheet is attached to this activity for you to use. Dictionaries are also available if you require them.  
You will be given 15-20 minutes to complete this task.
- When you have completed this you will be placed into teams (the teacher to decide) where you will compare your answers and produce an overall chart of results, as decided by your team.  
You will be given 15-20 minutes to complete this task.
- Finally the teams will discuss their results with the teacher and who will give the correct answers.  
This will take 15-20 minutes to complete.

## Activity

### Active verbs (words)

Identify	Describe	Evaluate
Justify	Explain	Evaluate critically
Analyse	Compare	Summarise
Contrast	Discuss	
Investigate/explore	Interpret	

### Results chart (including definitions):

Definition	Active verb
<ul style="list-style-type: none"> <li>To give reasons and/or the procedure for/how. Eg 'Why did you choose that method?' Or, 'How was the procedure undertaken?' A student would normally introduce the topic and then provide details showing depth and also a breadth of knowledge and/or skills about a topic.</li> <li>To examine minutely, breaking down into component parts and carrying out tasks which enable results to be interpreted, and findings presented.</li> <li>To examine a subject from all angles.</li> <li>To show the similarities and differences, or advantages and disadvantages between two or more things. Additionally, this may be extended by bringing together the findings in a description.</li> <li>Determine the amount, value or significance of by careful appraisal and study and including precise and detailed information, looking at alternatives and the strengths and weaknesses of each if they were applied in the same situation.</li> <li>To select and list item(s) as appropriate from information given or collected by the student.</li> <li>To clarify why a particular course of action was taken because of key reasons that were considered right at the time.</li> <li>To put forward both sides of an argument, this could be through group discussion or in writing.</li> <li>Show the differences between two or more things.</li> <li>To bring together all the main points of a subject.</li> <li>To paint a picture in words</li> <li>To carry out a review of activities/information and judge whether the outcomes met what was agreed/decided at the beginning; bringing together information to form a conclusion and from this making revisions for improvements.</li> <li>To define the meaning of.</li> </ul>	<p><i>Explain</i></p>

## Teacher's copy (including answers)

### Results chart (including definitions):

Definition	Active verb
<ul style="list-style-type: none"> <li>To give reasons and/or the procedure for/how. Eg 'Why did you choose that method?' Or, 'How was the procedure undertaken?' A student would normally introduce the topic and then provide details showing depth and also a breadth of knowledge and/or skills about a topic.</li> </ul>	<b>EXPLAIN</b>
<ul style="list-style-type: none"> <li>To examine minutely, breaking down into component parts and carrying out tasks which enable results to be interpreted, and findings presented.</li> </ul>	<b>ANALYSE</b>
<ul style="list-style-type: none"> <li>To examine a subject from all angles.</li> </ul>	<b>INVESTIGATE/EXPLORE</b>
<ul style="list-style-type: none"> <li>To show the similarities and differences, or advantages and disadvantages between two or more things. Additionally, this may be extended by bringing together the findings in a description.</li> </ul>	<b>COMPARE</b>
<ul style="list-style-type: none"> <li>Determine the amount, value or significance of by careful appraisal and study and including precise and detailed information, looking at alternatives and the strengths and weaknesses of each if they were applied in the same situation.</li> </ul>	<b>EVALUATE CRITICALLY</b>
<ul style="list-style-type: none"> <li>To select and list item(s) as appropriate from information given or collected by the student.</li> </ul>	<b>IDENTIFY</b>
<ul style="list-style-type: none"> <li>To clarify why a particular course of action was taken because of key reasons that were considered right at the time.</li> </ul>	<b>JUSTIFY</b>
<ul style="list-style-type: none"> <li>To put forward both sides of an argument, this could be through group discussion or in writing.</li> </ul>	<b>DISCUSS</b>
<ul style="list-style-type: none"> <li>Show the differences between two or more things.</li> </ul>	<b>CONTRAST</b>
<ul style="list-style-type: none"> <li>To bring together all the main points of a subject.</li> </ul>	<b>SUMMARISE</b>
<ul style="list-style-type: none"> <li>To paint a picture in words.</li> </ul>	<b>DESCRIBE</b>
<ul style="list-style-type: none"> <li>To carry out a review of activities/information and judge whether the outcomes met what was agreed/decided at the beginning; bringing together information to form a conclusion and from this making revisions for improvements.</li> </ul>	<b>EVALUATE</b>
<ul style="list-style-type: none"> <li>To define the meaning of.</li> </ul>	<b>INTERPRET</b>

## Help sheet

Active verb	Dictionary definitions and associated words
Analyse	Separate into elements or components; examine critically; determine constitute parts
Compare	Notice likenesses and differences
Contrast	Show differences
Describe	Give detailed account of
Discuss	Exchange opinions about; debate
Evaluate	Find or judge value of
Evaluate critically	Make clear; intelligible; a definite and precise account for
Explain	Make clear; intelligible; account for
Identify	Establish, identify or associate with
Interpret	Explain; translate
Investigate/explore	Inquire into; examine; investigate by going through it.
Justify	Prove right; vindicate
Summarise	Make a brief statement of main points of something



## Appendix K: Case studies

Case studies are useful tools to help with the delivery of the course and to bring in the vocational aspect. Two useful links to case studies are given below. This information was accurate at the time this document was published.

### **The Institution of Electrical Engineers**

[www.iee.org/oncomms/circuit/jobs/getajobtoolkit/day%5Fin%5Flife](http://www.iee.org/oncomms/circuit/jobs/getajobtoolkit/day%5Fin%5Flife)

### **Prospects**

[www.prospects.ac.uk/cms/ShowPage/Home\\_page/Explore\\_types\\_of\\_jobs/Types\\_of\\_Job/p!eipaL?state=showocc&idno=200&pageno=8](http://www.prospects.ac.uk/cms/ShowPage/Home_page/Explore_types_of_jobs/Types_of_Job/p!eipaL?state=showocc&idno=200&pageno=8)



# Appendix L: Useful strategies for students when tackling the internal units

## Unit 2: The Role of the Engineer

### Unit aims

In this unit you will investigate the role of an engineer when designing **and/or** manufacturing an engineered product **or** service. You will understand how new technologies, time and cost constraints, legislation and standards, and health and safety legislation influenced engineering decisions during the design **and/or** manufacture of an engineered product **or** service.

### Strategies

Below are some useful strategies that may help when you are completing the assessment for this unit. These suggestions for strategies should be read in conjunction with the relevant section in the GCE in Engineering specification – Unit 2: The Role of the Engineer.

#### Assessment evidence (a)

- Identify a company and a product or service that will allow you access to the higher mark bands – you will need help from your tutor to co-ordinate this event.
- Access background information about the company and their product range from the company brochure to set a context for your studies, perhaps a tour of the site would be very useful.
- Having identified a product or service within the company, provide some information about that product or service relating to its function or purpose and include any relevant specification points.
- You will need to interview an engineer from the company to examine their role in the design and/or manufacturing of the product or service.
- Identify clearly the job title of the engineer, perhaps a job description may be available.
- Carefully planned questions will need to be asked before your interview with the engineer so as not to waste time.
- How does the engineer assist in the design and/or manufacture of your product or service?
- Can you categorise tasks or activities under headings such as Planning, Quality, Production, Designing, Research and Development?
- Ask the engineer to explain these activities, what do the activities involve and why are they done? Take notes along the way.

#### Assessment evidence (b)

- You will need to observe the engineer in their environment and look at the technologies used to assist with the design and/or manufacture of your product or service.
- There are four headings to analyse in this section, CAD/CAM, Software Applications, Control Systems and Communications, make sure all four are covered.

#### *CAD/CAM*

- Does the engineer use CAD/CAM in designing and/or manufacturing?
- If so, what types of machine do they use and what do they do specifically?
- Why is the engineer using this technology?
- Are there alternative technologies?

### *Software applications*

- What software is the engineer using to carry out their activities?
- Examine a specific software application and question the engineer how it makes their work more effective and efficient.
- Why is the engineer using these particular software applications?
- Are there alternative software applications? Examine the pros and cons.

### *Control systems*

- What control systems are in place that the engineer has to consider when carrying out their activities?
- If dealing with manufacturing, how is the product or service produced?
- Are there specific machines used for your product or service?
- Why are these control systems used?
- Are there alternative systems available?

### *Communications*

- How does the engineer communicate with colleagues in the company?
- How does the engineer communicate with the customer?
- How does the engineer stay in touch while off site?
- Examples of the type of information communicated would prove very useful.
- An explanation of the devices used and why they are used for communication.

### **Assessment evidence (c)**

- Use [www.bsi-global.com](http://www.bsi-global.com) to identify the category which your product or service falls under. Here you will find appropriate standards for your product or service.
- The engineer may have access to these standards.
- You are not required to provide details of the entire standard but selected parts that are appropriate to your product or service.
- Are there any governing bodies responsible for regulating your product or service?
- Identify the main features or objectives of this regulatory body.
- Are there any CE markings for your product? Give details of them.
- What documentation is used within the company to track or monitor progress of your product or service?

### **Assessment evidence (d)**

- Examine the main health and safety legislations such as Health and Safety at Work Act, COSHH, Injury Reporting and RIDDOR.
- What precautions does the engineer take? Consider this when designing and/or manufacturing the product or service.
- Consider, also, the intended user and any employees that the engineer may be responsible for.
- Carry out your own risk assessments of particular aspects of your product or service.

**Assessment evidence (e)**

- Evaluate the intended performance of the product or service.
- Examine this from your own perspective and from the customer's point of view.
- Carry out tests on the product or service to see how it performs.
- Examine the initial specification and how it meets the customer's requirements.
- Consider the way the product has been manufactured or the service carried out.
- Discuss with the engineer how they would evaluate the product or service.

**Assessment evidence (f)**

- Give your opinion of how the product or service could be improved without prejudice.
- Produce drawings/sketches with notes to justify your decisions.
- Discuss modifications with your engineer.
- How would the engineer improve the product or service?



## Unit 3: Principles of Design, Planning and Prototyping

### Unit aims

In this unit, you will learn to read, interpret, understand and generate your own engineering drawings. You will produce a design solution and plan an engineered project that includes the manufacture of a prototype. You will then report back to your peers about the project in the form of a short presentation.

### Example task

A manufacturer of electronic/mechanical security products has identified a need for a dedicated device that will identify a specific pet and allow only that animal to pass through a locked and hinged flap set into a larger entry door to a house.

You have been asked to design and manufacture a device that will sense the presence of a specific pet and that will automatically unlock a small security flap. Once the flap has been unlocked and the pet has passed through, the flap must lock again.

### Strategies

Below are some useful strategies that may help when you are completing the assessment for this unit. These suggestions for strategies should be read in conjunction with the GCE in Engineering specification – Unit 3: Principles of Design, Planning and Prototyping. Some of the strategies given below relate to the example task given above. You should use these and adapt them to suit your own project.

#### Assessment evidence (b)

- Analyse the given brief and identify key areas for consideration.
- Research electronic sensing devices and how they can be made to respond to a unique signal.
- Gather information on existing sub-systems to investigate how they function.
- Research mechanical locking mechanisms and how they operate.
- Investigate time-delays and how they can be applied to the output of a sensing system to hold the output on or off for a limited period.
- Analyse the gathered information and write a technical specification under logical sub-headings.
- Include measurable points in the technical specification.
- Consult with the client to ensure all technical requirements are considered.

#### Assessment evidence (c)

- Produce a range (at least two), of technical design ideas that are significantly different to each other that consider electronic and mechanical systems.
- Use input, process, output to consider sensors, processing of the sensed signal and outputs that respond to the processed signal.
- Consider materials and processes to be used; use scientific and mathematical data to justify their choice where appropriate.
- Use 2D and 3D sketches and circuit diagrams to develop ideas.
- Consider and record appropriate health and safety requirements.
- Review each design proposal against the points of the technical specification and consult with the client for objective evaluation and feedback.

- Develop final design solution from initial ideas and client feedback; consult with client for objective evaluation.
- Consider and record appropriate health and safety requirements and justify their application.

**Assessment evidence (a)**

- Produce a range of engineering drawings that contain enough detail to manufacture the final design solution.
- Use industry-standard conventions and symbols when producing drawings.
- Use 2D and 3D CAD programs where appropriate; always use original 2D CAD drawings and not those generated automatically from 3D programs.
- Use a standard page layout for drawings that includes a border, title box etc.

**Assessment evidence (b) (continued)**

- Produce a plan for production that includes consideration of the main manufacturing processes with timings.
- Include a work order or sequence of making and assembly activities.
- Include a Gantt chart illustrating realistic timings for processes during manufacture.
- Include quality control and safety checks.
- Consider higher volume production than one-off.

**Assessment evidence (d)**

- Manufacture a prototype using high-level making skills to produce precision and attention to detail in the outcome.
- Produce a prototype that is fully functional and matches the final design solution in terms of dimensions, materials, function etc.
- Demonstrate high levels of safety awareness.
- Record the completed prototype using a series of clear photographs.
- Photograph normally-hidden detail such as mechanical details and electronic circuitry, including views of the solder side of circuit boards.

**Assessment evidence (e)**

- Prepare and deliver an oral presentation that gives a short but detailed description of the product during design and manufacture.
- Use high-quality ICT skills to aid the presentation.
- Use a maximum of 15 minutes for the presentation and describe and discuss the brief, design ideas and their rationale, how the final solution was developed, the selection of materials, processes and systems for manufacture.
- Review the final outcome objectively against the technical specification to determine its success.



## Unit 5: The Engineering Environment

### Unit aims

In this unit you will investigate a different engineered product or service to the one studied in Unit 2: The Role of the Engineer. You will extend your studies to learn how laws, regulations and codes of practice are used to ensure developments are safe. You will explore how procedures and paperwork systems are used to control engineering practice and product quality. You will learn about different ways in which the environment is protected by the way products are designed and manufactured. You will explore how new techniques and scientific advances are used to improve the way products work, and to create new products and services.

### Strategies

Below are some useful strategies that may help when you are completing the assessment for this unit. These suggestions for strategies should be read in conjunction with the GCE in Engineering specification – Unit 5: The Engineering Environment.

#### Assessment evidence (a)

- Identify a company and a product or service that will allow you access to the higher mark bands – you will need help from your teacher to co-ordinate it. Remember it has to be different from the one studied in Unit 2: The Role of the Engineer.
- Access background information about the company and their product range from the company brochure.
- Having identified a product or service within the company, provide some information about that product or service relating to its function or purpose and include any relevant specification points.
- You will need to interview an engineer from the company to identify the standards and regulations used that govern the engineered product or service.
- Use [www.bsi-global.com](http://www.bsi-global.com) to identify the category which your product or service falls under. You will find appropriate standards for your product or service here.
- The engineer may have access to these standards.
- You are not required to provide details of the entire standard just the selected parts appropriate to your product or service.
- Carefully planned questions will need to be asked before your interview with the engineer so as not to waste time.
- What activities does the engineer carry out in association with the product or service?
- How are these activities affected by the regulations and standards set?
- Examine the areas under the ‘Regulations and Standards’ section in 5.1 of this unit and see if any apply to your product or service by questioning the engineer.

#### Assessment evidence (b)

- Having identified and categorised activities centred around the product or service, provide evidence of documentation used to support each of these activities.
- Perhaps blank procedure documents could be used to provide details of how the product or service is monitored.
- Examine the areas to be covered under the ‘Documentation’ section in 5.1 of the unit.
- To obtain higher marks, evidence of documentation that covers more than one area is essential.

### **Assessment evidence (c) and (d)**

- You will need to study the areas covered in the specification under section 5.2 – ‘The Environmental Impact of Engineering Activities’, that have an environmental impact on the engineering activities for your product or service.
- Does the engineer consider energy efficiency when designing and/or manufacturing the product or service? If so, how?
- Are there any legal requirements for environmental protection that must be adhered to?
- Does the product or service contribute to global warming through its manufacturing processes?
- Do the waste materials contribute to the pollution of our environment?
- How does the company deal with waste management?
- Does the company use renewable resources and what are they?
- Identify the location of your company.
- How does the location affect local residents?
- Are there any traffic problems around the area that could be related to the company?
- Have there been any new transport links to provide better access to the company?

### **Assessment evidence (e)**

- You will need to question the engineer about the technologies and techniques used to develop, manufacture and maintain your product or service.
- What type of machinery is being used to design and/or manufacture your product or service?
- Why are these technologies used?
- Are there any alternatives that have been considered?
- Why were they rejected?
- Examine the materials under section 5.3 – ‘The Application of Technology in Engineering’, of the specification.
- What types of materials has the engineer used and why?
- Examine the communication techniques used under section 5.3 of the specification.
- To obtain higher marks, evidence of communication techniques and materials that covers more than one area is essential.

### **Assessment evidence (f)**

- Evaluate the intended performance of the product or service.
- Examine this from your own perspective and with a view to the customer.
- Carry out tests on the product or service to see how it performs.
- Examine the initial specification and how it meets customer requirements.
- Consider the way the product has been manufactured or the service carried out.
- Discuss with the engineer how they would evaluate the product or service.
- Give your opinion of how the product or service could be improved without prejudice.
- Produce drawings/sketches with notes to justify your decisions.
- Discuss modifications with your engineer.
- How would the engineer improve the product or service?

## Unit 6: Applied Design, Planning and Prototyping

### Unit aims

In this unit, you will design, develop and manufacture a solution to a client brief that will be given to you. You will carry out research, develop a technical specification, generate alternative ideas and develop them into a final design solution, plan for production, manufacture a prototype and evaluate it against the specification.

### Example task

An engineering company manufactures sewage pumps that are placed in remote locations. The pumps are left to operate for months at a time without any maintenance checks on their condition.

The pumps are filled with oil to lubricate bearings and if the condition of the oil deteriorates or leaks away, catastrophic damage can be caused to bearings, which leads to very expensive repairs or replacement.

You have been asked to design and manufacture a system that will monitor the condition and level of bearing oil in a pump.

The monitoring system should detect deterioration in oil condition and level and give an automatic warning to maintenance personnel that this is happening.

(The strategies offered as a route through the task described should be read in conjunction with the advice on delivery of units.)

### Strategies

Below are some useful strategies that may help when you are completing the assessment for this unit. These suggestions for strategies should be read in conjunction with the GCE in Engineering specification – Unit 6: Applied Design, Planning and Prototyping. Some of the strategies given below relate to the example task given above. You should use these and adapt them to suit your own project.

#### Assessment evidence (a)

- Analyse the design brief and identify key areas for consideration.
- Consult the client to establish key requirements of the problem presented.
- Research sub-systems for monitoring liquid levels and condition, examine comparators and level sensors, changing capacitance in oscillator circuits in different qualities of oil, automatic dial-up systems.
- Gather information on existing similar products using the internet and manufacturers' information, to find out how they work.
- Select relevant information from research that is detailed, technical and has scientific/mathematical justification.
- Analyse the gathered information and write a technical specification under logical sub-headings.
- Include measurable points in the technical specification.
- Consult with the client to ensure all technical requirements are considered.

### **Assessment evidence (b)**

- Generate a range of alternative design ideas for each element of the problem.
- Use researched technical information to justify design decisions.
- Match each design idea against the technical specification to ensure that it is relevant to the needs of the problem.
- Review design ideas and consult with the client for objective evaluation and feedback.
- Specify appropriate materials and components based on scientific/mathematical information.
- Consider and record appropriate health and safety requirements.
- Use high-quality presentation skills when producing initial ideas.
- Develop and refine a final engineering design solution.
- Use features and sub-systems from initial ideas as a basis for some parts of the final design solution.
- Show significant changes and how the final solution has been moved on during development.
- Consider commercial manufacturing requirements.
- Use current industry standards and conventions to produce appropriate working drawings of the final design solution.
- Use 2D and 3D CAD to model work where appropriate.
- Use schematic PCB drawing programs to produce electronic circuitry.
- Use prototyping board to test circuit design in the 'real world'.

### **Assessment evidence (c)**

- Set up a constructive discussion group with the client and other engineers (peers).
- Discuss and comment objectively on the final design solution for the monitoring system.
- Record useful feedback based on the evaluation of design points against the technical specification.
- Decide how the final design solution could be modified to improve its performance in light of the objective comments made from within the group.
- Plan for possible changes to the final design solution and consider the implications in terms of cost, materials, components etc.
- Make detailed notes of any proposed alterations or modifications to be made using accurate technical language.

### **Assessment evidence (d)**

- Produce a plan for production that includes consideration of the main manufacturing processes with timings appropriate to the scale of production.
- Include a work order or sequence of making and assembly activities.
- Include a Gantt chart illustrating realistic timings for processes during manufacture.
- Include quality control and safety checks.
- Consider budgetary constraints.
- Consider higher volume production than one-off
- Include any relevant regulations, standards and documentation that will influence product manufacture and explain their importance.

### **Assessment evidence (e)**

- Manufacture a prototype using high-level making skills to produce precision and attention to detail in the outcome.
- Produce a fully-working prototype that matches the final design solution in terms of materials, function, design details, dimensions etc.
- Select materials components and processes using scientific/mathematical justification where appropriate.
- Demonstrate high levels of safety awareness.
- Record the completed prototype using a series of clear photographs.
- Photograph normally-hidden detail such as mechanical details and electronic circuitry, including views of the solder side of circuit boards.

### **Assessment evidence (f)**

- Test and evaluate the final outcome objectively against the technical specification.
- Describe tests carried out to check the performance and quality of the monitoring system and justify them to say why they are being carried out.
- Concentrate testing on the measurable points listed in the technical specification.
- Develop tests to use over an extended period of time and monitor results.
- Use test results and the views of potential users to inform the evaluation of the engineered product.
- Evaluate objectively the monitoring system against the measurable points of the technical specification and support statements with evidence.
- Organise evaluation statements to avoid rambling and repetitive accounts that are descriptions of activities during manufacture, rather than evaluative statements based on tests and checks.
- Suggest modifications for improvement to the performance or quality of the monitoring system using evidence from testing and evaluation and user-group feedback. Each suggestion should arise from a different evaluation or test.

Further copies of this publication are available from  
Edexcel Publications, Adamsway, Mansfield, Notts, NG18 4FN

Telephone: 01623 467467  
Fax: 01623 450481  
Email: [publications@linneydirect.com](mailto:publications@linneydirect.com)

Publications Code UA015842 August 2005

For more information on Edexcel and BTEC qualifications please contact  
Customer Services on 0870 240 9800  
or <http://enquiries.edexcel.org.uk>  
or visit our website: [www.edexcel.org.uk](http://www.edexcel.org.uk)

Edexcel Limited. Registered in England and Wales No. 4496750  
Registered Office: One90 High Holborn, London WC1V 7BH

