

Surname	Centre Number	Candidate Number
Other Names		



GCE A level

1144/01

ELECTRONICS

ET4

P.M. WEDNESDAY, 25 January 2012

1 hour

For Examiner's use only		
Question	Maximum Mark	Mark Awarded
1.	5	
2.	4	
3.	7	
4.	6	
5.	8	
6.	4	
7.	7	
8.	9	
Total	50	

ADDITIONAL MATERIALS

In addition to this examination paper, you will need a calculator.

INSTRUCTIONS TO CANDIDATES

Use black ink or black ball-point pen.

Write your name, centre number and candidate number in the spaces at the top of this page.

Answer **all** questions.

Write your answers in the spaces provided in this booklet.

INFORMATION FOR CANDIDATES

The total number of marks available for this paper is 50.

The number of marks is given in brackets at the end of each question or part-question.

You are reminded of the necessity for good English and orderly presentation in your answers.

You are reminded to show all working. Credit is given for correct working even when the final answer given is incorrect.

INFORMATION FOR THE USE OF CANDIDATES

Preferred Values for resistors

The figures shown below and their decade multiples and sub-multiples are the E24 series of preferred values.

10, 11, 12, 13, 15, 16, 18, 20, 22, 24, 27, 30, 33, 36, 39, 43, 47, 51, 56, 62, 68, 75, 82, 91.

Standard Multipliers:

Prefix	Multiplier
T	$\times 10^{12}$
G	$\times 10^9$
M	$\times 10^6$
k	$\times 10^3$

Prefix	Multiplier
m	$\times 10^{-3}$
μ	$\times 10^{-6}$
n	$\times 10^{-9}$
p	$\times 10^{-12}$

Filters

$$f_b = \frac{1}{2\pi RC}$$

Break frequency for high pass and low pass filters

$$X_C = \frac{1}{2\pi fC}$$

Capacitive reactance

$$X_L = 2\pi fL$$

Inductive reactance

$$Z = \sqrt{R^2 + X_C^2}$$

For a series RC circuit

$$f_0 = \frac{1}{2\pi\sqrt{LC}}$$

Resonant frequency

$$R_D = \frac{L}{r_L C}$$

Dynamic resistance

$$Q = \frac{2\pi f_0 L}{r_L}$$

$$Q = \frac{f_0}{B}$$

Modulation

$$m = \frac{(V_{\max} - V_{\min})}{(V_{\max} + V_{\min})} \times 100\%$$

Depth of modulation

$$\beta = \frac{\Delta f_c}{f_i}$$

Modulation index

$$\text{Bandwidth} = 2(\Delta f_c + f_i)$$

Transmitted FM Bandwidth

$$\text{resolution} = \frac{\text{i/p voltage range}}{2^n}$$

PCM

Radio receivers

$$C = \frac{1}{4\pi^2 f_0^2 L}$$

BLANK PAGE

1. A **non-inverting** Schmitt trigger circuit has the following characteristic.

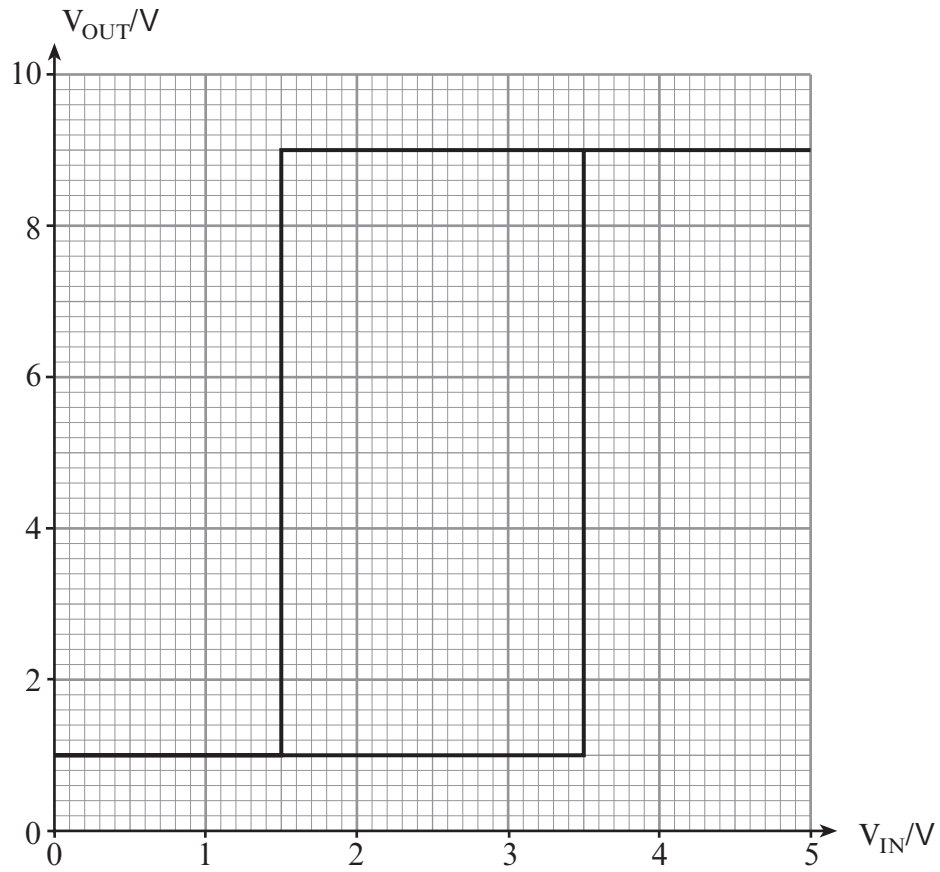

- (a) (i) Write down the switching thresholds for this Schmitt trigger.

..... and

[1]

- (ii) Write down the saturation values for this Schmitt trigger.

..... and

[1]

- (b) Draw the output for this Schmitt trigger if the following analogue signal is applied to the input. [3]

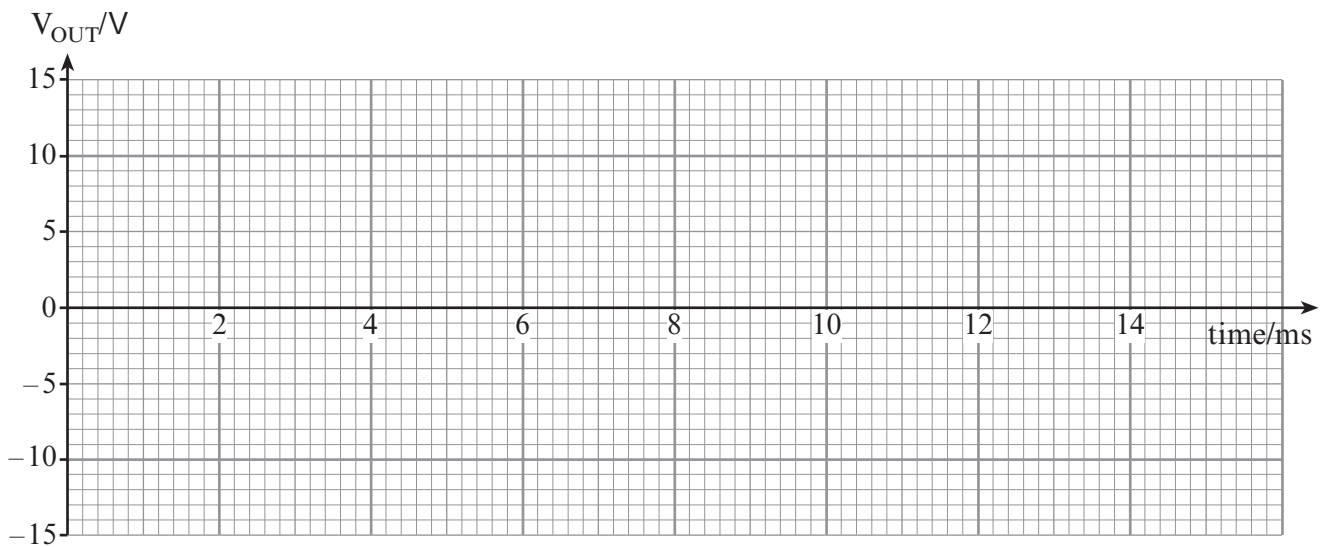
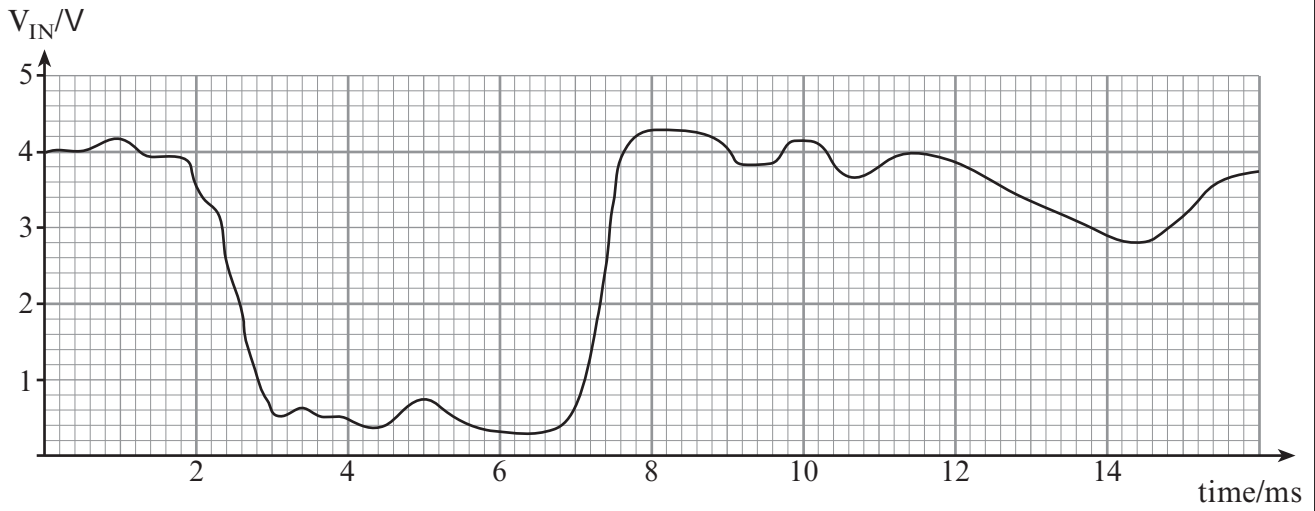

2. A filter is tested to determine its response to different types of input signal. A block diagram of the test system arrangement is also shown below.

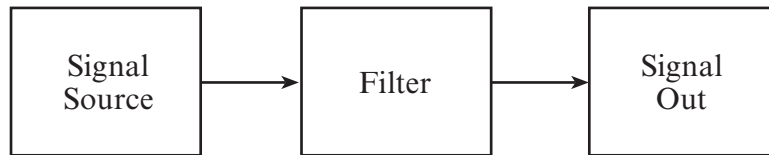

The frequency response of the filter is shown in the following graph.

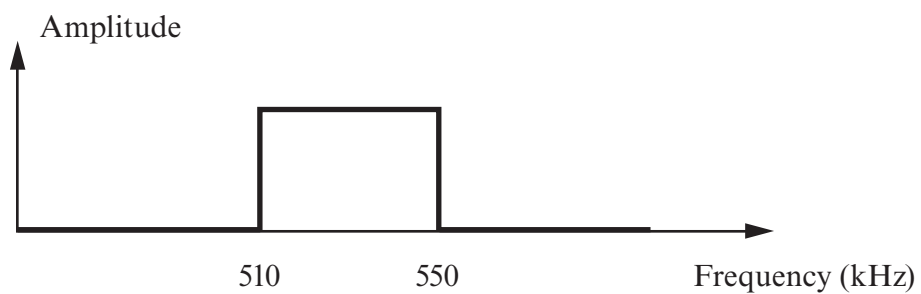

- (a) What is the name of this type of filter?

[1]

- (b) An AM signal having the following frequency spectrum is applied to the filter.

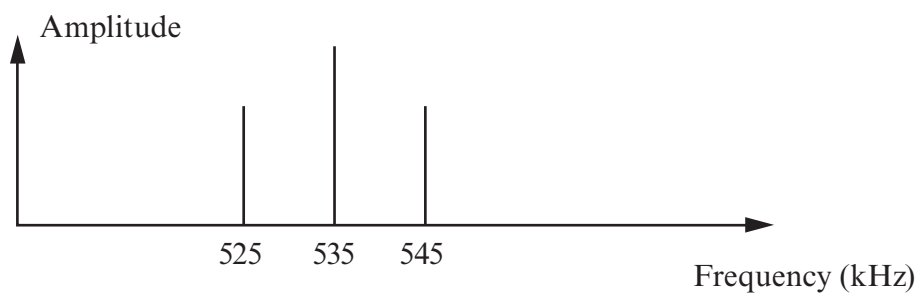

Sketch the frequency spectrum of the output you would expect to see at the output of the filter, labelling any relevant frequencies.



[1]

- (c) An FM signal having the following frequency spectrum is applied to the filter.

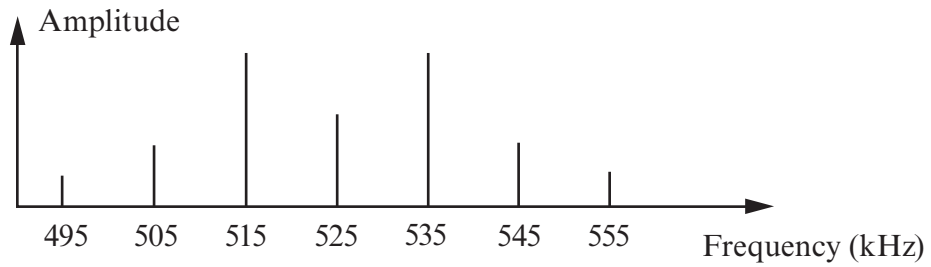

Sketch the frequency spectrum of the output you would expect to see at the output of the filter, labelling any relevant frequencies.



[1]

- (d) Finally a square wave signal having the following frequency spectrum is applied to the filter.

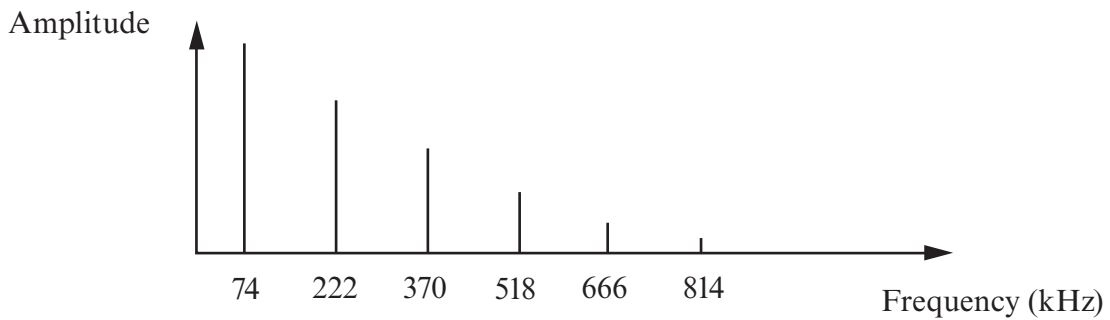

Sketch the frequency spectrum of the output you would expect to see at the output of the filter, labelling any relevant frequencies.



[1]

3. The simple radio receiver is made from five functional blocks. The blocks are shown below.

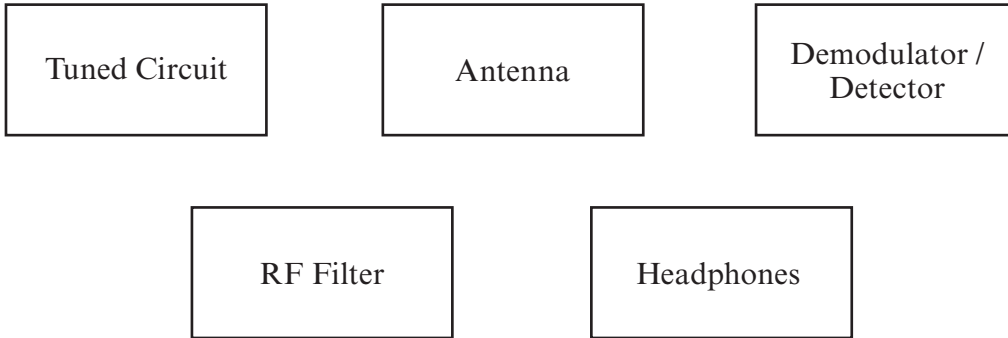

(a) Draw a block diagram in the space below to show how these blocks are connected to make a simple radio receiver.

[1]

(b) Name the component used in the demodulator / detector block.

..... [1]

(c) Name the components that make up the tuned circuit.

..... and [1]

(d) The simple radio receiver has two major disadvantages: *poor sensitivity* and *poor selectivity*.

Explain what is meant by:

(i) poor selectivity;

.....
.....
.....
.....

(ii) poor sensitivity.

.....
.....
.....
.....

[2]

(e) The superheterodyne radio receiver improves the selectivity and sensitivity compared to the simple radio receiver.

Name **four additional** functional blocks that would be found in a superheterodyne receiver.

-
-
-
-

[2]

4. Pulse Amplitude Modulation (PAM), Pulse Width Modulation (PWM), and Pulse Position Modulation (PPM) are three methods of modulating information.

On each of the following graphs, illustrate what would happen to the unmodulated clock pulse train (shown dotted) if the input signal below were transmitted using:

- (i) PAM
- (ii) PWM
- (iii) PPM

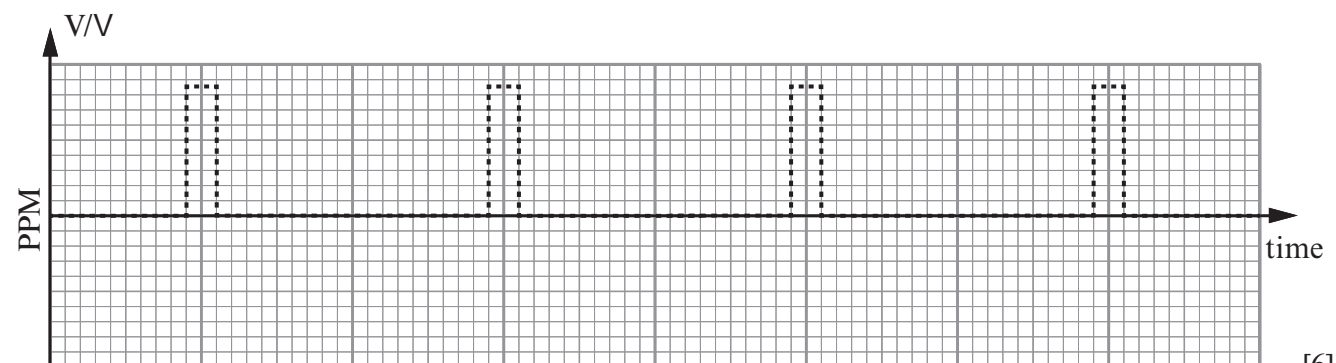
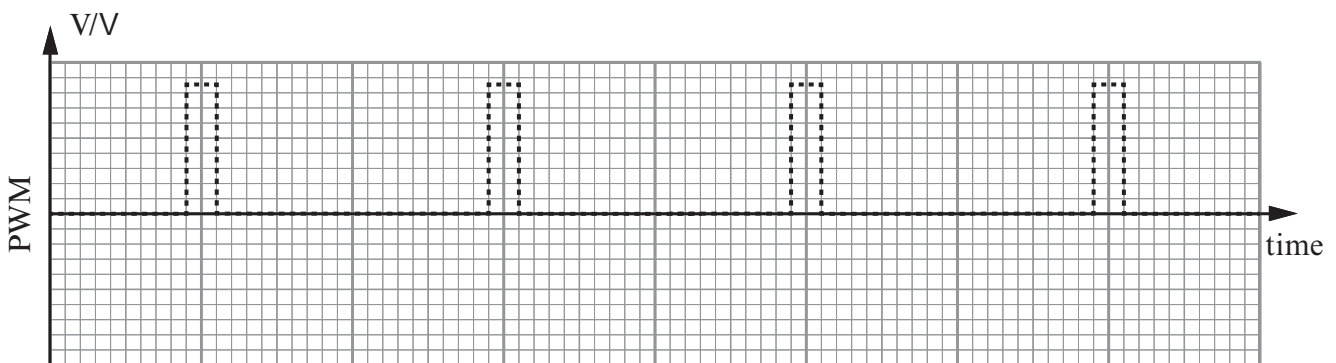
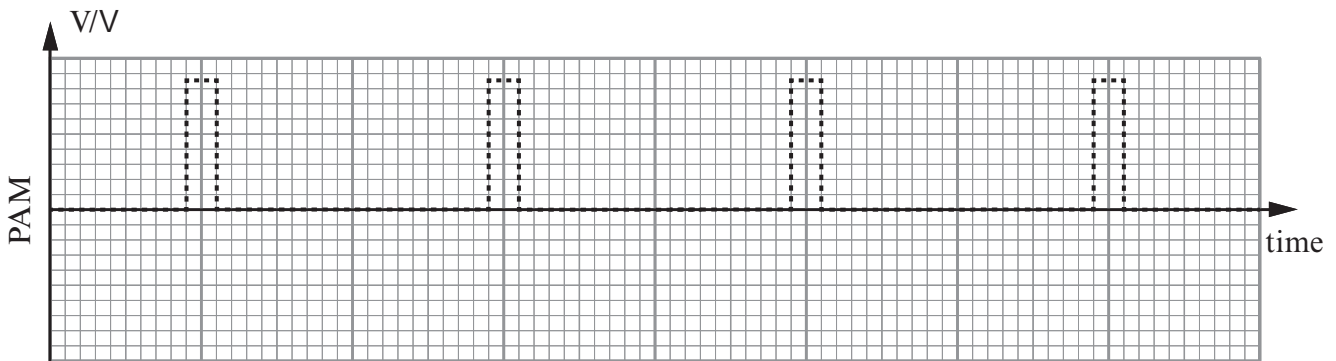
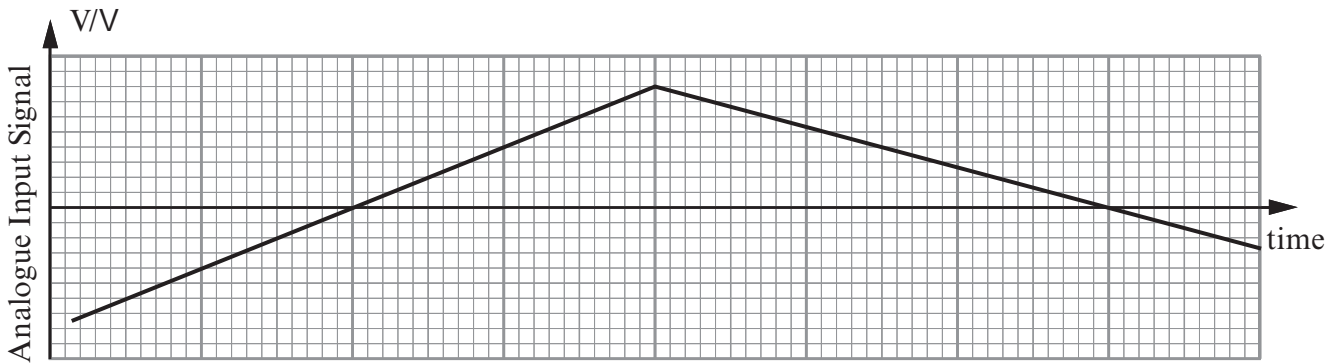

[6]

5. Here is the circuit diagram for a passive RC filter connected to a signal generator.

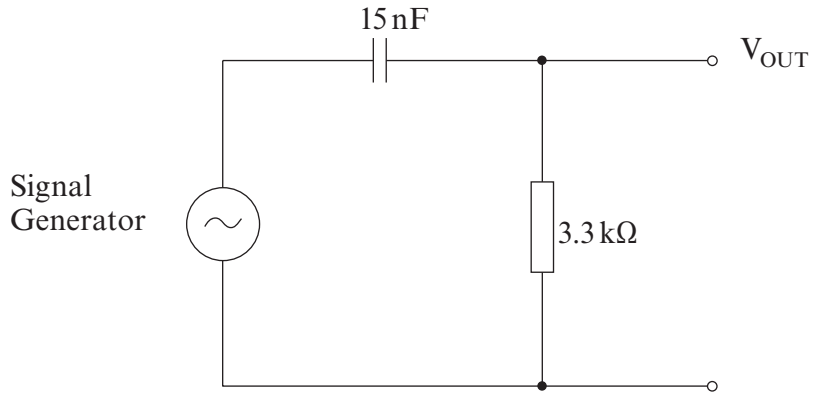

(a) What is the name of this type of passive RC filter? [1]

(b) Calculate the reactance of the capacitor at 10 Hz.

 [2]

(c) Estimate the reactance of the capacitor at 100 kHz.
 [1]

(d) Calculate the break frequency for this filter.

 [2]

(e) Sketch the frequency response of this filter.

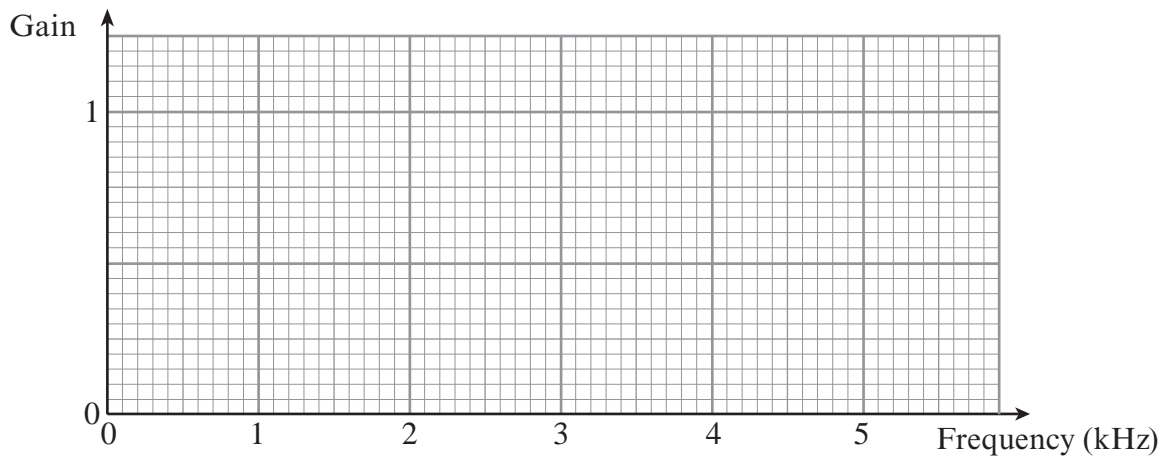

[2]

6. A non-inverting Schmitt trigger is required to have saturation values of $\pm 12\text{V}$, and switching thresholds of $\pm 3\text{V}$.

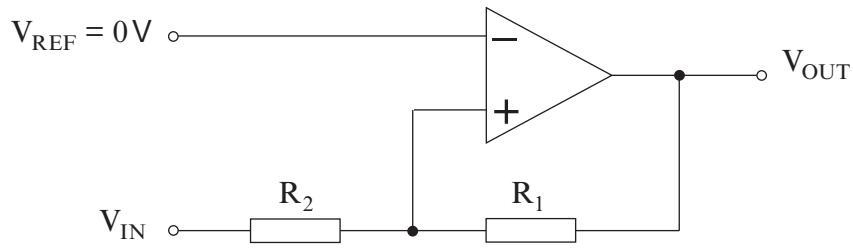

- (a) Explain why the switching thresholds for this circuit are symmetrical about zero volts.

.....

.....

[1]

- (b) Determine suitable values for R_1 and R_2 .

.....

.....

.....

.....

.....

.....

.....

.....

.....

.....

$R_1 = \dots\dots\dots$ $R_2 = \dots\dots\dots$

[3]

7. The block diagram shows part of a Pulse Code Modulation (PCM) transmitter.

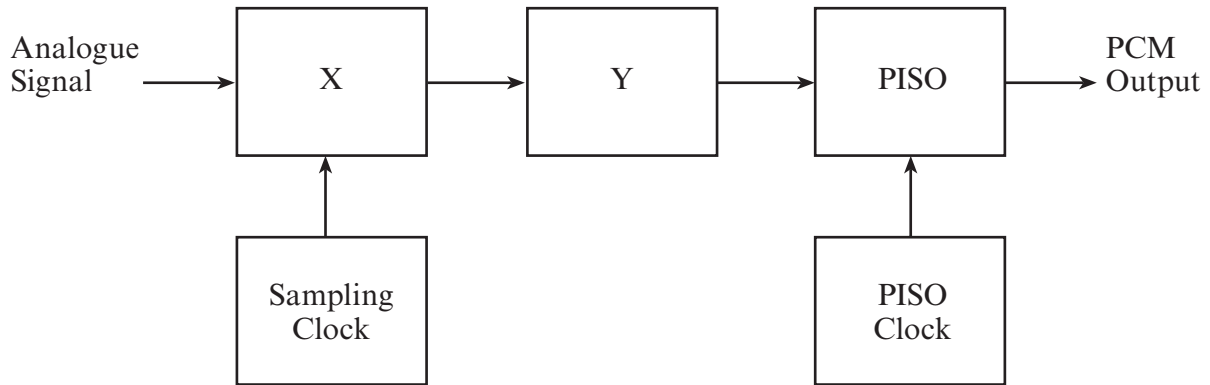

(a) Identify the blocks labelled X and Y.

(i) Block X = [1]

(ii) Block Y = [1]

(b) The following information gives details about a communications link which uses Time Division Multiplexing (TDM) in conjunction with PCM.

Use the information to answer the questions which follow.

- Each PCM channel uses a sampling frequency of 16 kHz to convert audio signals in the range 20 Hz to 5.5 kHz into digital form.
- A 12-bit code is used to define the sampling levels.
- Five identical PCM channels are to be incorporated into the TDM communications link.

(i) How many sampling levels are available using a 12-bit code?

..... [1]

(ii) Calculate the PCM sampling period.

..... [1]

(iii) What is the minimum frequency of the high frequency clock to allow all five PCM channels to be incorporated into a TDM communications link?

..... [3]

8. (a) A computer system uses **odd** parity. Start, stop and parity bits have to be added before a signal can be transmitted.
The computer system transmits the character S. The ASCII code for the character S is 1010011.

(i) What is the logic state of the parity bit?

[1]

(ii) Complete the graph to show the transmitted signal for the character S. Label the start, stop and parity bits.

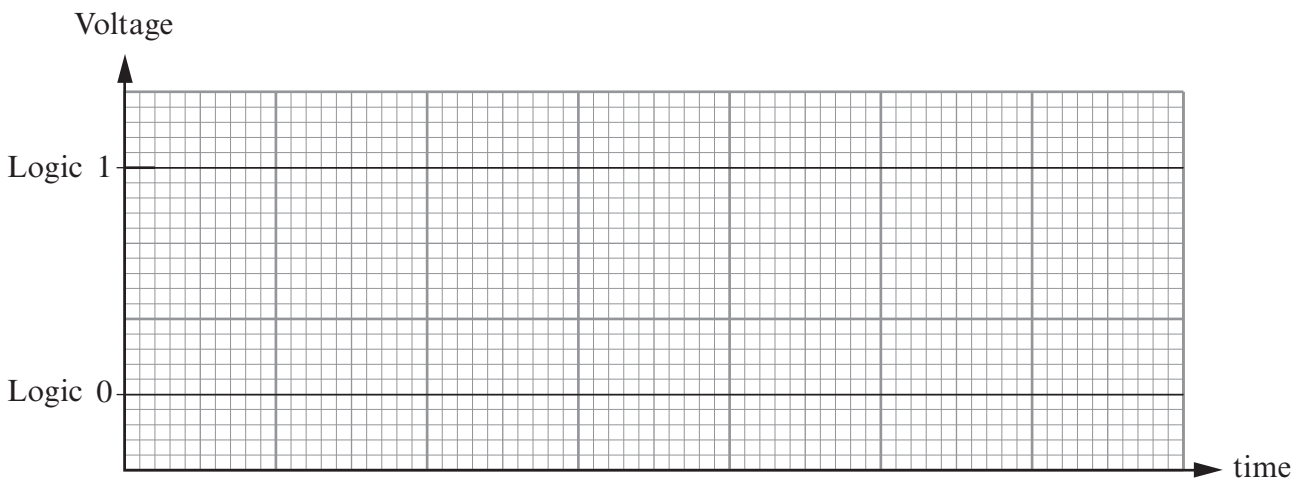

[4]

(b) A high-quality transmission system uses a five bit parity system, which allows single errors in the transmission to be detected and also corrected. The parity bits are assigned to the data bits in accordance with the following table.

D ₇	D ₆	D ₅	D ₄	D ₃	D ₂	D ₁	D ₀	P ₄	P ₃	P ₂	P ₁	P ₀
				x	x	x	x					x
x	x	x	x								x	
		x	x			x	x			x		
	x	x			x	x			x			
x	x			x	x			x				

- (i) The following data is to be transmitted along a transmission line using this system.

D₇								D₀
0	1	1	1	0	1	0		1

Determine the values of the parity bits P₄ - P₀ that should be transmitted after this data for an **even** parity system.

P₄ = P₃ = P₂ = P₁ = P₀ = [2]

- (ii) In a later transmission, using the same system, the following data and parity bits are received from a distant source. The transmission system was using **even** parity.

D₇								D₀	P₄					P₀
1	0	0	1	1	0	0		1	1	1	0	1		0

There is a **single** error in the received data. By careful consideration of the received data, determine where the error is located and therefore write down the correct version of the received data.

D ₇	D ₆	D ₅	D ₄	D ₃	D ₂	D ₁	D ₀	P ₄	P ₃	P ₂	P ₁	P ₀
								1	1	0	1	0

[1]

Explain how you have determined the location of the error.

.....

.....

.....

.....

.....

[1]

THERE ARE NO MORE QUESTIONS IN THIS EXAMINATION.

