

## Teacher Resource Bank

GCE Electronics

Exemplar Exam Questions:

- ELEC1 Introductory Electronics



## ELEC1 – Introductory Electronics

### Systems (ELE1, Q2, 2006)

2 A student designs an electronic system to turn on a 12 V lamp for a fixed period of time when it gets dark.

(a) Choosing appropriate input, process, and output sub-systems, label the system diagram below to show a possible design for the lamp and its controller.



*(5 marks)*

(b) In which sub-system could

(i) an op-amp be used, .....

(ii) an LDR be used, .....

(iii) a MOSFET be used? .....

*(3 marks)*

(c) The whole system draws a current of 15 mA when the lamp is off. The current increases to 515 mA when the 12 V lamp is on.

Calculate

(i) the lamp current, .....

(ii) the power rating of the lamp. ....

*(3 marks)*

**Zener Regulator (ELE1, Q6, 2008 – ELE1, Q7, 2007 – ELE1, Q6, 2005)**

6 A zener diode is used to regulate the output voltage of a power supply to 5.1 V when an input voltage between 7 V and 9.6 V is applied.

6 (a) Add a zener diode and its current limiting resistor to complete the circuit diagram below.



(4 marks)

6 (b) The minimum zener current should be 5 mA under all conditions. The maximum output current required is 60 mA.

6 (b) (i) Calculate the minimum voltage across the resistor.

.....

6 (b) (ii) What current flows through the resistor when the output current is 60 mA?

.....

6 (b) (iii) Calculate the required resistor value.

.....

6 (b) (iv) Which preferred E24 resistor value should be chosen?

.....

6 (b) (v) Calculate the power dissipated by the resistor when the input voltage is 9.6 V and the output current is 60 mA.

.....

.....

6 (b) (vi) Explain whether a 0.25 W power rating would be suitable for the resistor.

.....

(8 marks)

- 7 The power supply circuit shown below gives an output voltage of 5.1 V when connected to a 9 V battery.  
 The 9 V battery gives an output of 9.6 V when it is new, falling to 7 V at the end of its useful life.

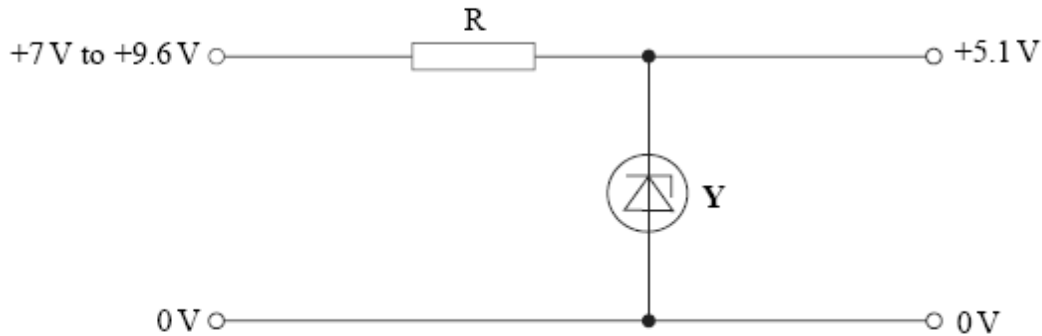

- (a) (i) Name the component **Y** in the circuit.

.....

- (ii) What voltage rating should be chosen for **Y**?

.....

- (iii) In which bias direction is component **Y** connected?

.....

(4 marks)

- (b) The maximum output current from this circuit is 50 mA.  
 Under this condition the current through **Y** is 5 mA.  
 Calculate

- (i) the current flow through **R**,

.....

- (ii) the voltage across **R** when the input voltage is 7 V,

.....

- (iii) the required value of resistance **R**,

.....

- (iv) which preferred value should be chosen for **R** if the current through **Y** is not to fall below 5 mA.

.....

(5 marks)

- (c) A new battery which has a voltage of 9.6 V is connected to the input of this circuit with the value of R chosen in part (b)(iv).

Calculate

- (i) the new voltage across R,

.....

- (ii) the new current through R,

.....

- (iii) the power now dissipated by R.

.....

*(4 marks)*

- (d) With the new battery and when no current is drawn from the output of the circuit calculate

- (i) the current through component Y,

.....

- (ii) the power dissipated by component Y.

.....

*(2 marks)*

- (e) (i) Calculate the maximum useful output power delivered by this circuit.

.....

- (ii) Comment on the efficiency of this circuit for providing a stable 5.1 V output voltage from a small 9 V battery.

.....

.....

*(3 marks)*

- 6 A regulated voltage supply circuit is shown below. The input voltage varies from 10 V to 14 V. The required output voltage is 7.5 V.

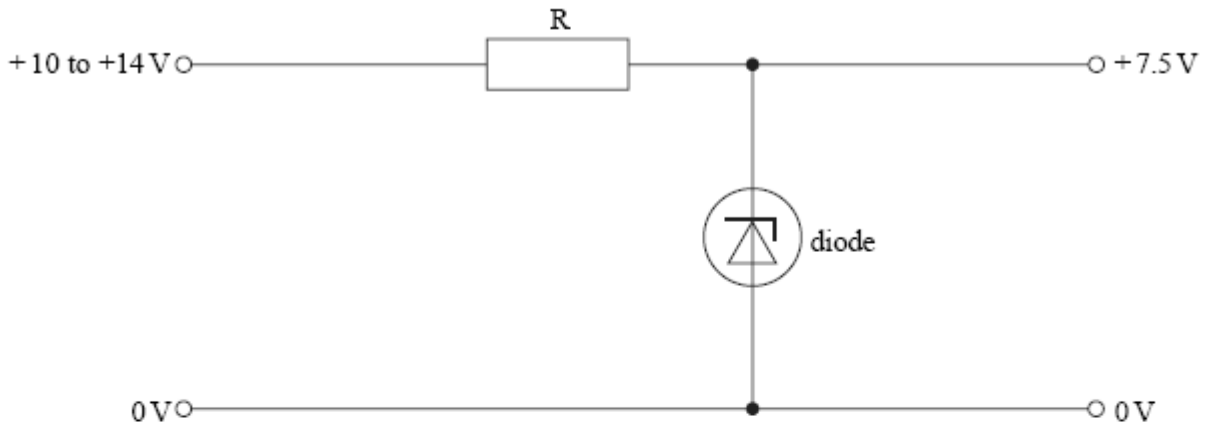

- (a) (i) Name the type of diode required in this circuit.

.....

- (ii) What voltage rating should be chosen for the diode?

.....

- (iii) In which bias direction is the diode connected?

.....

(3 marks)

- (b) The minimum diode current is 10 mA. The required output current from the circuit is 100 mA.

- (i) Calculate the current through the resistor, R, when the output current is 100 mA.

.....

- (ii) Calculate the voltage across R when the input voltage is at its minimum of 10 V.

.....

- (iii) Calculate the required resistance of R.

.....

- (iv) Which preferred value of resistance should be chosen in this case?

.....

(5 marks)

(c) The input voltage now rises to its maximum of 14 V.

(i) Calculate the voltage across R.

.....

(ii) Calculate the current through R at this voltage using the value of R from part (b) (iv).

.....

(iii) Calculate the power dissipated by R at this voltage.

.....

(iv) Resistors are available in power ratings of 0.25 W, 0.5 W, 1 W, 2 W and 4 W.  
Which is the lowest acceptable power rating for the resistor?

.....

*(6 marks)*

(d) The power supply input voltage remains at 14 V, but no current is drawn from the output of the regulator circuit.

(i) What is the current through the diode under these conditions?

.....

(ii) Calculate the power dissipated by the diode under these conditions.

.....

(iii) This type of diode is available in 0.4 W, 1.3 W and 5 W ratings. Choose the most suitable rating for this diode.

.....

*(4 marks)*

### Light Level Detector Sub-Systems (ELE1, Q4, 2008)

- 4 A student designs a very simple light level detector which indicates when the light level falls, as a reminder to switch on a reading lamp to avoid eye strain.

Since the detector is to be battery powered, it must have a **minimum** power consumption.

The following data is gathered about the devices that could be used.

For the input sensor:

LDR type	resistance at 10 lux
a	200 kΩ
b	94 kΩ
c	20 kΩ

For the processing stage:

type	relevant information
NOT gate 4049	Power consumption 0.001 mW
op-amp TL081	Supply current 1.4 mA
op-amp 741	Supply current 1.7 mA

For the output stage:

device	relevant information
filament lamp	6 V 0.06 A
red LED	$V_f$ 2V @ 10 mA

- 4 (a) Choosing from the tables above, select a suitable device and type for each of the subsystems that would result in the lowest current drawn from the battery. Label the system diagram with them.



(3 marks)

- 4 (b) The system could be designed to indicate low light by either switching the output device on or off. Which would be better? Give your reason.

.....

.....

(2 marks)



- 4 (c) The LDR has a resistance of  $150\text{k}\Omega$  at the light level at which the system should alert the user. The chosen processing stage requires an input voltage of  $4.5\text{V}$  to switch. Draw the circuit diagram of a voltage divider that would give a rising voltage as the light level falls marking the output connection and suitable value for the component other than the LDR.

\_\_\_\_\_ o +9V

\_\_\_\_\_ o 0V

*(3 marks)*

- 4 (d) The output of the process stage is  $7.3\text{V}$ , and the minimum output current that will operate the output device is  $3\text{mA}$  at  $1.9\text{V}$ .

Calculate the value of a series resistor for the output device.

.....  
 .....

*(2 marks)*

### Temperature Sensor (ELE1, Q3, 2005)

3 An electronic system is designed to turn on an LED when the room temperature rises to a set level.

The circuit diagram of the temperature sensor is shown below.

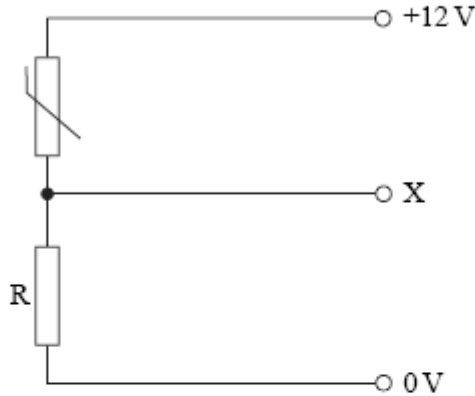

(a) The thermistor used in the circuit has a resistance of  $45\text{ k}\Omega$  at  $0^\circ\text{C}$ ,  $13\text{ k}\Omega$  at  $25^\circ\text{C}$  and  $1\text{ k}\Omega$  at  $100^\circ\text{C}$ .

(i) Calculate the value of the resistor,  $R$ , that would give a current of  $1\text{ mA}$  through the thermistor when the temperature is  $100^\circ\text{C}$ .

.....  
 .....

(ii) Using the value of  $R$  from part (i), calculate the output voltage at  $X$  when the temperature is  $25^\circ\text{C}$ .

.....  
 .....

(5 marks)

(b) The temperature sensor is connected to an op-amp comparator circuit which gives a positive output to turn on an LED when the temperature rises to  $25^\circ\text{C}$ . Draw a circuit diagram of the whole system. Component values are not required.

(4 marks)

### Output Drivers (ELE1, Q6, 2007)

6 A student designs an automatic porch light that will switch on when it gets dark. To give enough light a 40 W lamp that operates from 12 V is chosen.

(a) Why can this lamp **not** be controlled directly from a comparator or logic gate?

.....  
.....

*(1 mark)*

(b) The student then considers the choice of lamp drivers available.

(i) Name **two** semiconductor active devices that could be used to control the lamp.

1.....

2.....

(ii) Which electromagnetic device could also be used?

.....

(iii) What other component must be used with the electromagnetic device to protect the rest of the circuit?

.....

*(4 marks)*

**Transistor Driver and Colour Codes (ELE1, Q5, 2005)**

- 5 An npn junction transistor is used to switch the current through a 12 V 6 W lamp. The input signal to the transistor is from a logic circuit that gives an output of 5 mA at 5 V. The circuit is shown below.

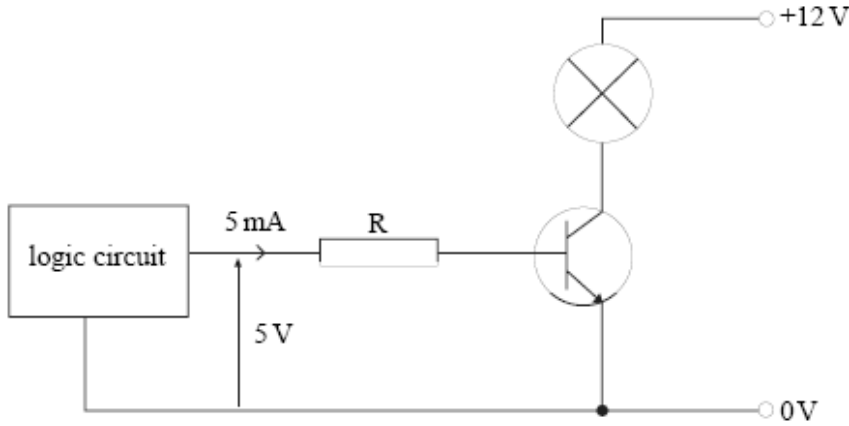

- (a) The base-emitter voltage of the transistor when switched on is 0.7 V.
- (i) Calculate the voltage across the resistor, R, when the transistor is switched on.  
 .....  
 .....
  - (ii) Calculate the resistance of R required to limit the base current to 5 mA.  
 .....  
 .....
  - (iii) Resistors of this value are not available. Which two identical resistors from the E24 series would combine to give the required resistance?  
 .....
  - (iv) Write the colour code for **one** of these resistors if it has a 5% tolerance.  
 .....  
 ..... (9 marks)
- (b) (i) Calculate the collector current of the transistor when the lamp is fully switched on.  
 .....  
 .....
- (ii) Calculate the required current gain (ratio of collector current to base current) of the transistor in this circuit.  
 .....  
 ..... (4 marks)

**MOSFET Switch for Motor (ELE1, Q5, 2006)**

5 A MOSFET is used as a switch to control a motor connected to a 12 V supply. The motor is found to run too fast when switched directly to the supply by the MOSFET and a resistor R is placed in series with the motor to slow it down.

- (a) (i) Complete the circuit diagram below to show how the motor and resistor are connected.

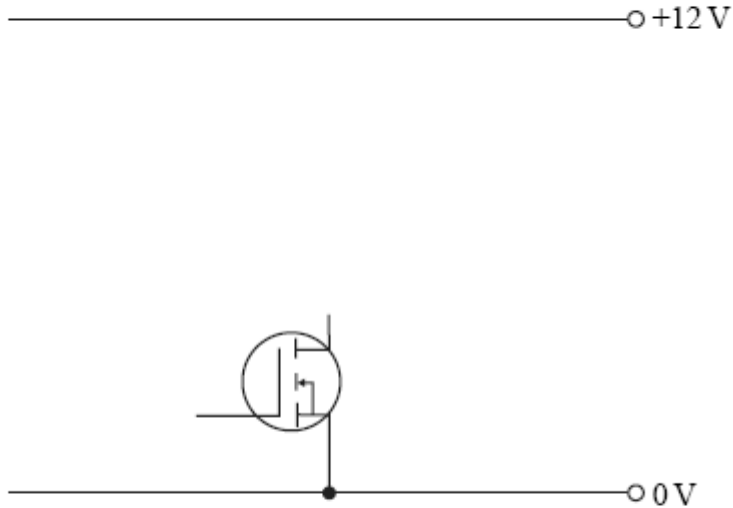

- (ii) Draw on the circuit diagram above a component required to protect the MOSFET from the back emf generated by the motor. (5 marks)
- (b) When running at the correct speed, the motor has 4 V across it and a current of 150 mA flowing through it.
- (i) Calculate the voltage across R. ....
- (ii) Calculate the required resistance of R. ....  
.....
- (iii) Calculate the power dissipated by R when the motor is running.  
.....
- (iv) Which is the closest value of resistance available from the E24 series for resistor R?  
.....
- (v) What will be the effect on the speed of the motor of using the preferred value in part (b)(iv) instead of the calculated value in part (b)(ii)?  
.....

- (vi) Choose a suitable power rating for this resistor from the ratings given below by circling the appropriate value.

0.5 W

1 W

4 W

7 W

11 W

- (vii) What type of resistor construction would be best for this application?
- .....

- (viii) This type of resistor is most likely to have a BS1852 code printed on it for its value and tolerance. Write on the diagram below the code you would expect to see for its value and 5% tolerance.

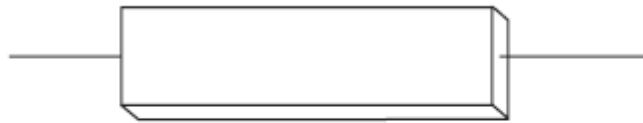

- (ix) What physical factor should you consider when mounting this component on a circuit board?
- .....

*(13 marks)*

**Transistor Driver and Relay (ELE1, Q3, 2008)**

3 An npn junction transistor is to be used as a switch to control an electromagnetic relay.

3 (a) (i) Complete the circuit diagram to show how the transistor is connected, label the leads of the transistor in the spaces shown.

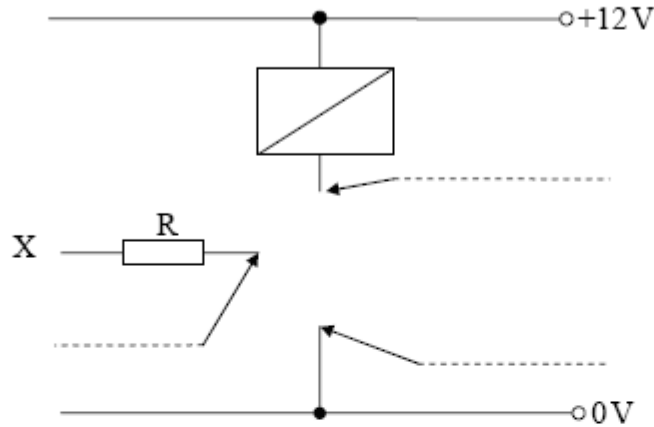

3 (a) (ii) Add to the diagram the component required to protect the transistor from the back emf of the relay.

*(6 marks)*

3 (b) The relay coil has a resistance of  $240\ \Omega$ .

3 (b) (i) Calculate the collector current of the transistor when the relay is switched on.

.....  
 .....

3 (b) (ii) The transistor has a current gain (ratio of collector current to base current) of 50. Calculate the minimum base current when the relay is switched on.

.....  
 .....

3 (b) (iii) The input voltage at X which saturates the transistor is 4.7V. Calculate the value of R, the resistor required.

.....  
 .....

3 (b) (iv) Choose the most appropriate value for R from the E24 series.

.....  
*(5 marks)*

**Temperature Sensor and Comparator (ELE1, Q4, 2007)**

4 A temperature sensor input subsystem is shown below.

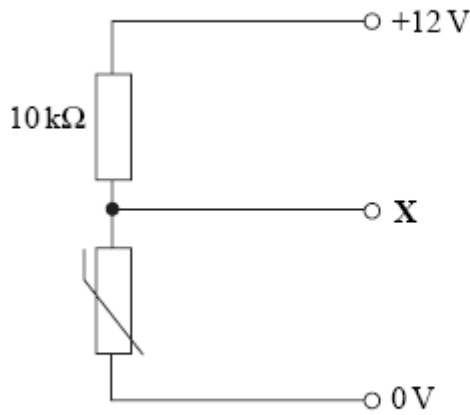

(a) The thermistor shown above has a resistance of 30 kΩ at 0 °C, 15 kΩ at 25 °C, and 2 kΩ at 100 °C.

(i) At what temperature given above will the current through the circuit be the largest?

.....

(ii) Explain why the maximum current will flow at this temperature.

.....

(iii) Calculate the value of this current.

.....

.....

(iv) Calculate the output voltage at X at this temperature.

.....

.....

(5 marks)



(b) The temperature sensor subsystem is to be connected to a comparator circuit to detect when the water in an electric kettle boils.

(i) What reference voltage must the comparator have to detect boiling water?

.....

(ii) Draw a suitable circuit for the comparator if it is to produce a high output when the water boils.

Choose suitable values for the resistors in the voltage divider, labelling them on your circuit diagram.

*(5 marks)*

### LDR and Comparator (ELE1, Q4, 2006)

4 Part of a comparator circuit is shown below.

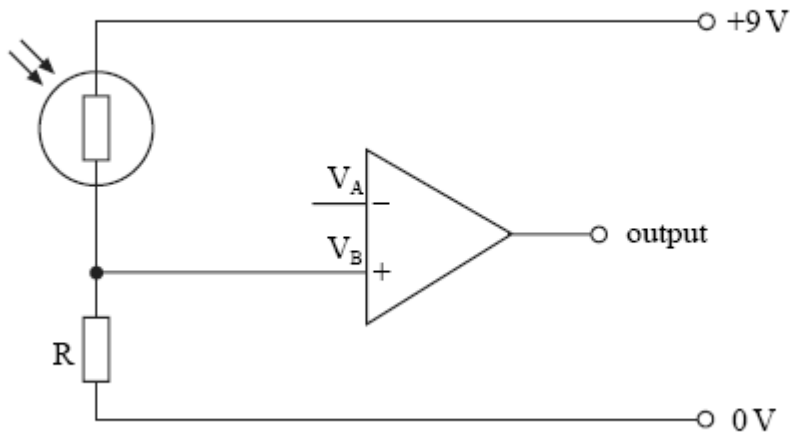

- (a) The op-amp input  $V_A$  requires a reference voltage of 3 V.
- (i) On the circuit diagram above draw **two** components and their connections to show how this is achieved.
  - (ii) Select suitable values for these components and mark these on the circuit diagram next to each component.
- (4 marks)*

(b) The LDR has a maximum power dissipation of 90 mW.

- (i) Calculate the maximum current that could safely flow through the LDR if it had 9 V across it.

.....

- (ii) Calculate the combined resistance of the LDR and R that would allow this current to flow.

.....

.....

- (iii) The LDR has a minimum resistance of  $100\ \Omega$  in very bright light. Calculate the value of R required if the current calculated in part (b)(i) is **not** to be exceeded.

.....

- (iv) Choose a suitable value from the E24 series if the current limit is **not** to be exceeded.

.....  
(5 marks)

- (c) State the output voltage from the op-amp in the circuit diagram on page 8 when  $V_A > V_B$

(i) if an ideal op-amp is used, .....

(ii) if a real op-amp is used. ....

(2 marks)

- (d) State the output voltage from the op-amp in the circuit diagram on page 8 when  $V_A < V_B$

(i) if an ideal op-amp is used, .....

(ii) if a real op-amp is used. ....

(2 marks)

**Logic Gates (ELE1, Q1, 2006 – ELE1, Q1, 2007 – ELE1, Q1, 2008 – ELE1, Q1, 2005)**

1 The truth table for a logic circuit is shown below.

A	B	C	D	Q
0	0	1	0	0
0	1	1	1	1
1	0	1	1	1
1	1	0	1	0

- (a) Inputs A and B are both connected to two gates, having outputs C and D. C and D then form the inputs to a third gate providing the output Q. In the space below draw the logic circuit that would give these outputs.

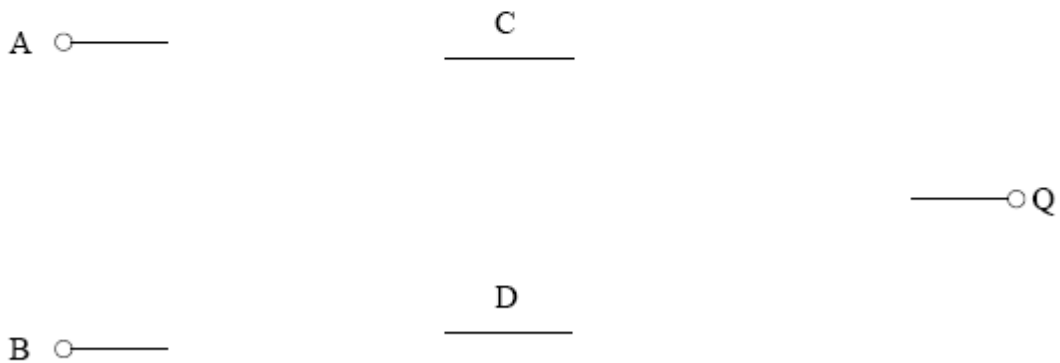

(5 marks)

- (b) Using the truth table above, write the simplest Boolean expression for the logic signals at C and D in terms of the inputs A and B.

C = .....

D = .....

(3 marks)

- (c) Write the simplest Boolean expression for Q in terms of the inputs A and B.

Q = .....

(2 mark)

1 The Boolean equation for a logic circuit with inputs A and B and output Q is

$$Q = (\bar{A} + \bar{B}) \cdot (A + B)$$

- (a) Complete the truth table to show the logic values of the terms below for all the combinations of variables A and B.

A	B	$\bar{A}$	$\bar{B}$	$\bar{A} + \bar{B}$	A + B	Q
0	0					
0	1					
1	0					
1	1					

(5 marks)

- (b) Complete the diagram below to show how a logic circuit can be constructed from **two** NOT gates, **two** OR gates and **one** AND gate to represent the Boolean equation above.

A ○ —

— ○ Q

B ○ —

(5 marks)

- (c) State which single logic gate has the same function as the complete circuit above.

.....  
(1 mark)

1 A logic circuit diagram is shown below.

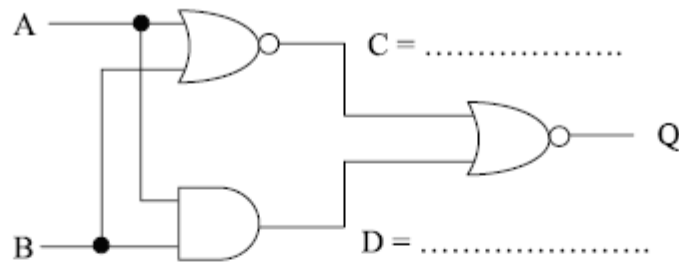

1 (a) Write the simplest Boolean expressions for the logic signals at points C and D on the diagram above in the spaces provided. (2 marks)

1 (b) (i) Write the simplest Boolean expression for Q in terms of C and D only.

Q = .....

1 (b) (ii) Write a simple Boolean expression for Q in terms of A and B only.

Q = .....

(3 marks)

1 (c) Complete the truth table to show the logic values of C, D and Q for all the combinations of variables A and B.

A	B	C	D	Q
0	0			
0	1			
1	0			
1	1			

(4 marks)

1 (d) Draw a logic circuit diagram in the space below using a single logic gate that would have the same function as the original circuit.

(2 marks)

1 A logic circuit is shown below.

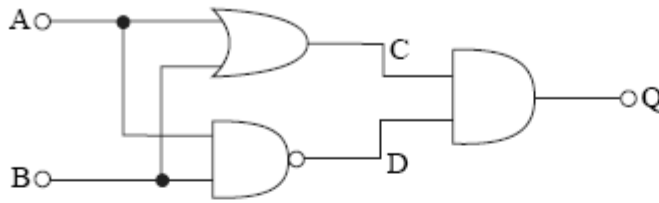

(a) Complete the truth table below to show the operation of this logic circuit.

A	B	C	D	Q
0	0			
0	1			
1	0			
1	1			

(4 marks)

(b) Write the Boolean expressions for the signals at points C and D in terms of the inputs A and B.

C = .....

D = .....

(2 marks)

(c) Write a Boolean expression for Q

(i) in terms of C and D, Q = .....

(ii) in terms of A and B, Q = .....

(2 marks)

(d) A single gate can replace the combination of gates above.

(i) Name the gate. ....

(ii) Draw the logic circuit symbol for this gate.

(2 marks)

**Boolean (ELE2, Q1, 2008)**

- 1 Temporary traffic lights are used to control the traffic at roadworks. The traffic lights have a 16-step binary sequence as shown in the table below where R = red, Y = amber, G = green.

D	C	B	A	traffic lights 1	traffic lights 2
0	0	0	0	R	G
0	0	0	1	R	G
0	0	1	0	R	G
0	0	1	1	R	G
0	1	0	0	R	G
0	1	0	1	R	G
0	1	1	0	R	Y
0	1	1	1	R, Y	R
1	0	0	0	G	R
1	0	0	1	G	R
1	0	1	0	G	R
1	0	1	1	G	R
1	1	0	0	G	R
1	1	0	1	G	R
1	1	1	0	Y	R
1	1	1	1	R	R, Y

- 1 (a) State the value of the step, in hexadecimal, when only the amber lamp is illuminated in traffic lights 1.

.....  
(1 mark)

- 1 (b) Explain why the Boolean expression when the green lamp of traffic lights 1 is illuminated is given by

$$G = D \cdot \bar{C} \cdot \bar{B} \cdot \bar{A} + D \cdot \bar{C} \cdot \bar{B} \cdot A + D \cdot \bar{C} \cdot B \cdot \bar{A} + D \cdot \bar{C} \cdot B \cdot A + D \cdot C \cdot \bar{B} \cdot \bar{A} + D \cdot C \cdot \bar{B} \cdot A$$

.....  
 .....  
 .....  
 .....  
 .....  
(2 marks)



1 (c) Show that the expression in part (b) simplifies to:

$$G = D \cdot \overline{B \cdot C}$$

.....

.....

.....

.....

.....

.....

.....

.....

.....

*(3 marks)*

1 (d) Draw a circuit diagram to show how you would implement the simplified logic expression using several 2-input NAND gates.

*(3 marks)*

This page is intentionally blank

## Teacher Resource Bank

GCE Electronics

Exemplar Exam Questions – Mark Scheme

- ELEC1: Introductory Electronics



**Systems (ELE1, Q2, 2006)**

2 (a)

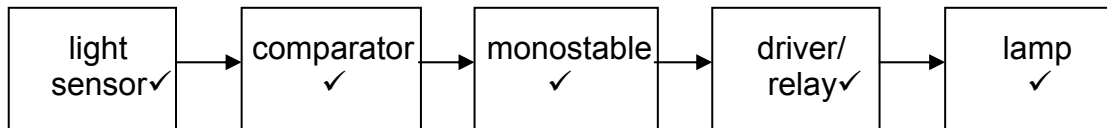

(5 marks)

- (b) (i) comparator ✓  
 (ii) light sensor ✓  
 (iii) driver ✓

(3 marks)

- (c) (i)  $515 - 15 = 500 \text{ mA}$  ✓  
 (ii)  $P = V \times I = 12 \times 0.5 = 6 \text{ W}$  ✓

(3 marks)

(question total 11 marks)

**Zener Regulator (ELE1, Q6, 2008 – ELE1, Q7, 2007 – ELE1, Q6, 2005)**

6 (a) (i)

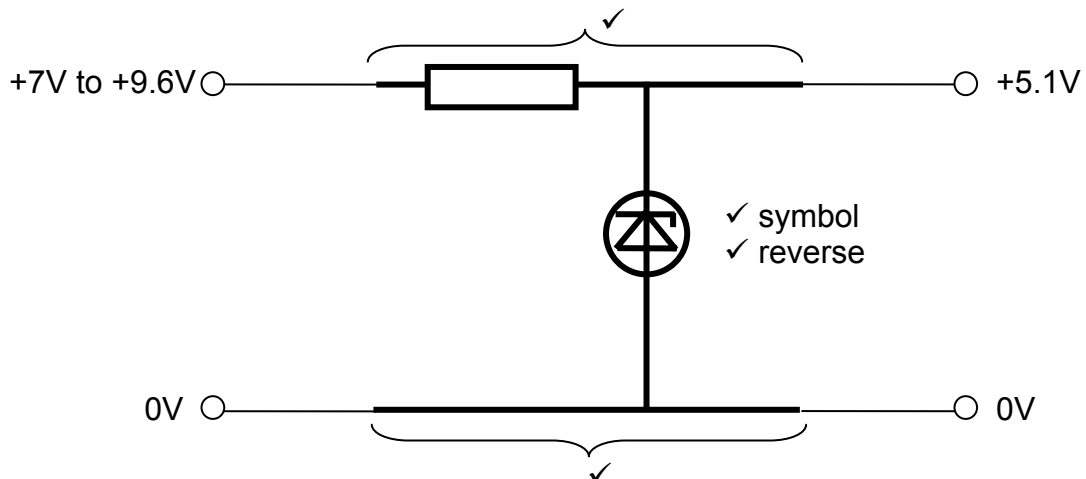

- (b) (i)  $7 - 5.1 = 1.9 \text{ V}$  ✓  
 (ii)  $60 + 5 = 65 \text{ mA}$  ✓  
 (iii)  $1.9 \div 0.065 = 29 \Omega$  ✓  
 (iv)  $27 \Omega$  ✓  
 (v)  $9.6 - 5.1 = 4.5 \text{ V}$      $4.5^2 \div 27 = 0.75 \text{ W}$  ✓ ✓  
 (vi)  $\frac{1}{4} \text{ W}$  is  $< 0.75 \text{ W}$  ✓

(question total 12 marks)

- 7 (a) (i) zener✓ diode✓  
(ii) 5.1V✓  
(iii) reverse✓ (4 marks)
- (b) (i)  $50 + 5 = 55\text{mA}$ ✓  
(ii)  $7 - 5.1 = 1.9\text{V}$ ✓  
(iii)  $1.9 \div 0.055 = 34.5\Omega$ ✓  
(iv)  $33\Omega$ ✓ (5 marks)
- (c) (i)  $9.6 - 5.1 = 4.5\text{V}$ ✓  
(ii)  $4.5 \div 33 = 0.136\text{A}$ ✓  
(iii)  $0.136 \times 4.5 = 0.6\text{W}$ ✓ (4 marks)
- (d) (i)  $0.136\text{A}$ ✓  
(ii)  $5.1 \times 0.136 = 0.7\text{W}$ ✓ (2 marks)
- (e) (i)  $5.1 \times 0.05 = 0.255\text{W}$ ✓  
(ii) efficiency is low✓  
wasteful use of energy stored in small 9V battery✓ (3 marks)

(Total 18 marks)

- 6 (a) (i) zener✓  
(ii) 7.5 V✓  
(iii) reverse✓ (3 marks)
- (b) (i) 110 mA✓  
(ii)  $10 - 7.5 = 2.5\text{V}$ ✓  
(iii)  $2.5 / 0.11 = 22.7\Omega$ ✓  
(iv)  $22\Omega$ ✓ (5 marks)
- (c) (i)  $14 - 7.5 = 6.5\text{V}$ ✓  
(ii)  $6.5 / 22 = 295\text{mA}$ ✓  
(iii)  $6.5 \times 0.295 = 1.9\text{W}$ ✓  
(iv)  $2\text{W}$ ✓ (6 marks)
- (d) (i) 295 mA✓  
(ii)  $7.5 \times 0.295 = 2.2\text{W}$ ✓  
(iii)  $5\text{W}$ ✓ (4 marks)

(4 marks)  
**Total 18 marks**

**Light Level Detector Sub-Systems (ELE1, Q4, 2008)**

4 (a)

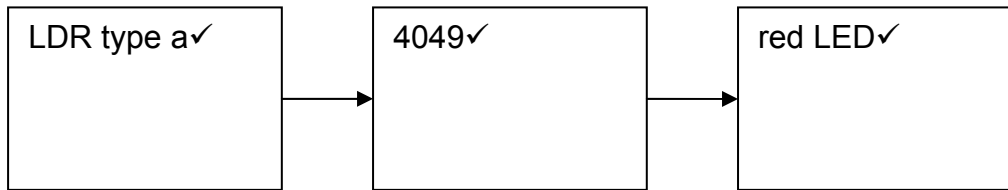

(b) LED switches on in the dark ✓  
so least current is used when monitoring ✓

(c)

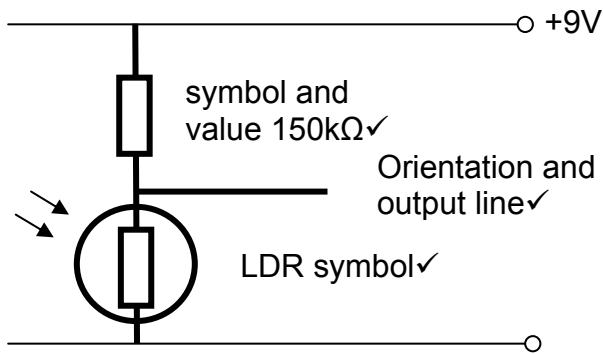

(d)  $7.3 - 1.9 = 5.4V$  ✓       $5.4 \div 0.003 = 1800\Omega$  ✓

**Total – 10**

**Temperature Sensor (ELE1, Q3, 2005)**

3 (a) (i)  $R = V/I$        $12/1 = 12k\Omega$  ✓ total res,  $-1k\Omega$  ✓ =  $11k\Omega$  ✓  
(ii)  $11/24 \times 12 =$  ✓       $5.5 V$  ✓

3 (b)

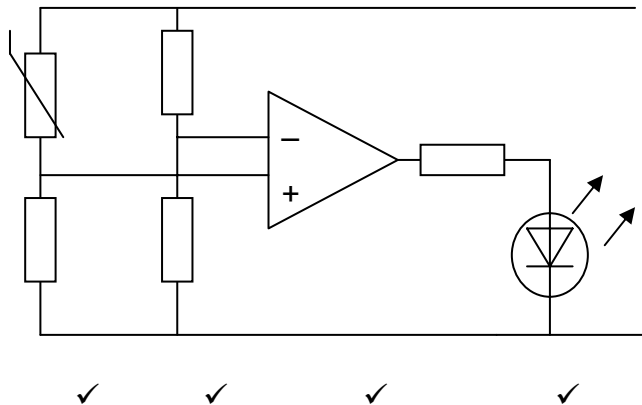

(4 marks)  
**Total 9 marks**

**Transistor Driver and Colour Codes (ELE1, Q5, 2005)**

- 5 (a) (i)  $5 - 0.7 = \checkmark$  4.3 V $\checkmark$   
 (ii)  $4.3 / 0.005 = \checkmark$  860  $\Omega$  $\checkmark$   
 (iii) 430  $\Omega$  $\checkmark$   
 (iv) yellow $\checkmark$  orange $\checkmark$   
 brown $\checkmark$  gold $\checkmark$

(9 marks)

- 5 (b) (i)  $6 / 12 = \checkmark$  0.5 A $\checkmark$   
 (ii)  $500 / 5 = \checkmark$  100 $\checkmark$

(4 marks)

**Total 13 marks**

**MOSFET Switch for Motor (ELE1, Q5, 2006)**

- 5 (a) (i) and (ii)

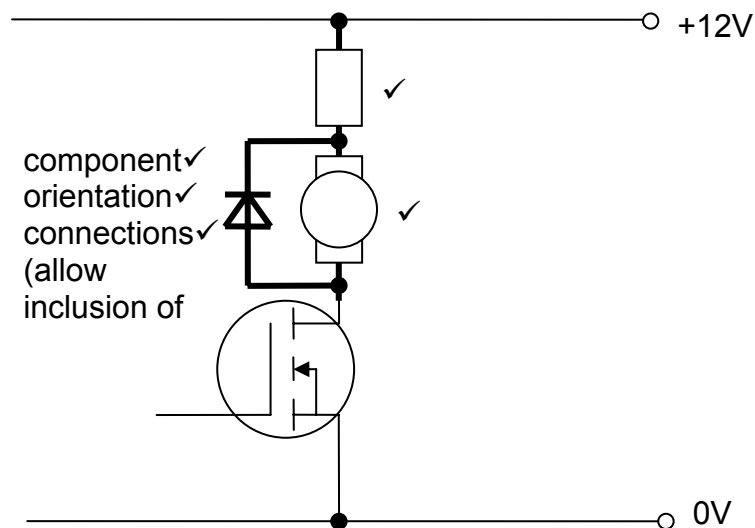

(5 marks)

- (b) (i)  $12 - 4 = 8V$  $\checkmark$   
 (ii)  $8 / 0.15 = 53\Omega$  $\checkmark$   
 (iii)  $8 \times 0.15 = 1.2W$  $\checkmark$   
 (iv) 51 $\Omega$  $\checkmark$   
 (v) motor runs faster, or has more voltage across it,  
 or more current $\checkmark$   
 (vi) 4W $\checkmark$

(vii) wirewound✓

✓ ✓ ✓

(viii)

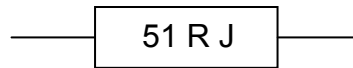

(ix) air circulation, or mount off board, or air gap, or heat dissipation✓

(13 marks)  
(question total 18 marks)

**Transistor Driver and Relay (ELE1, Q3, 2008)**

- 3 (a) (i) npn transistor symbol✓ collector✓ base✓ emitter✓  
 (ii) diode symbol✓ effectiveness in circuit position✓
- (b) (i)  $12 \div 240 = 0.05\text{A}$  or  $50\text{mA}$ ✓  
 (ii)  $50 \div 50 = 1\text{mA}$ ✓  
 (iii)  $4.7 - 0.7 = 4.0\text{V}$ ✓  $4.0 \div 0.001 = 4000\Omega$ ✓  
 (iv)  $3.9\text{k}\Omega$ ✓

**Total – 11**

**Temperature Sensor and Comparator (ELE1, Q4, 2007)**

- 4 (a) (i)  $100^\circ\text{C}$ ✓  
 (ii) the thermistor has its minimum resistance at this temp. ✓  
 (iii) tot res =  $10\text{k} + 2\text{k} = 12\text{k}$ ✓  $I = V \div R$ ,  $12\text{V} \div 12\text{k} = 1\text{mA}$ ✓  
 (iv)  $V_o = (2 \div (10 + 2)) \times 12\text{V} = 2\text{V}$ ✓

(5 marks)

- (b) (i)  $2\text{V}$ ✓  
 (ii)

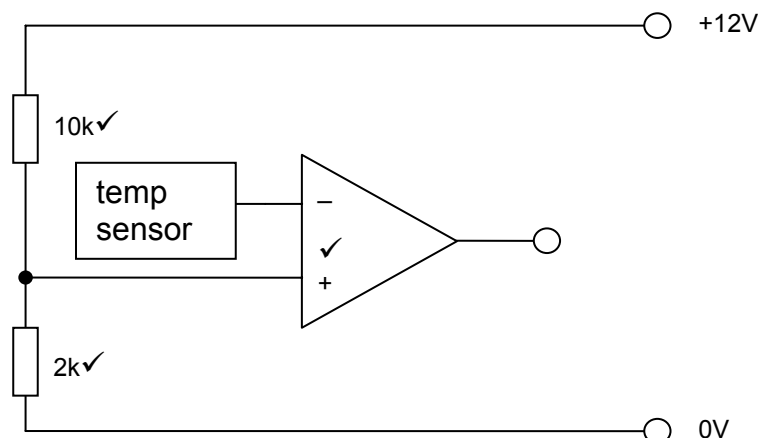

(5 marks)  
(Total 10 marks)



**LDR and Comparator (ELE1, Q4, 2006)**

4 (a) (i) and (ii)

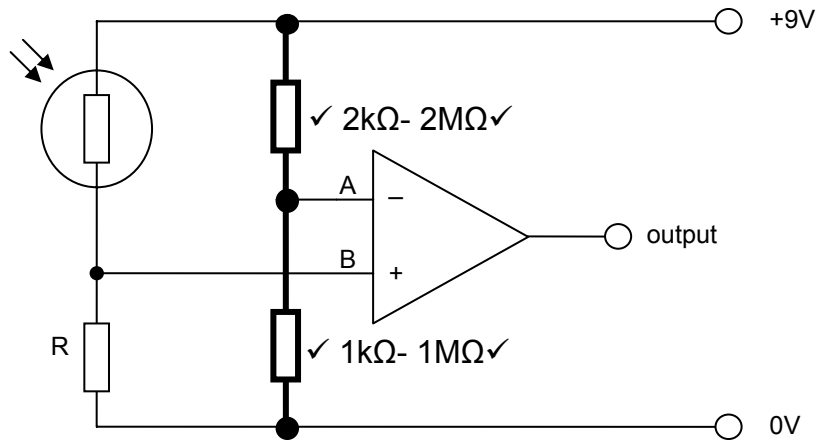

(4 marks)

- (b) (i)  $I = P/V = 90/9 = 10 \text{ mA}$  ✓  
 (ii)  $R = V/I = 9/0.01 = 900\Omega$  ✓ (allow ecf)  
 (iii)  $900 - 100 = 800\Omega$  ✓ (allow ecf)  
 (iv)  $820\Omega$  ✓ (allow ecf)

(5 marks)

- (c) (i)  $0V$  ✓  
 (ii)  $0.1 - 3V$  ✓

(2 marks)

- (d) (i)  $9V$  ✓  
 (ii)  $6 - 8.9V$  ✓

(2 marks)

(question total 13 marks)

**Logic Gates**

(ELE1, Q1, 2006 – ELE1, Q1, 2007 – ELE1, Q1, 2008 – ELE1, Q1, 2005)

1 (a)

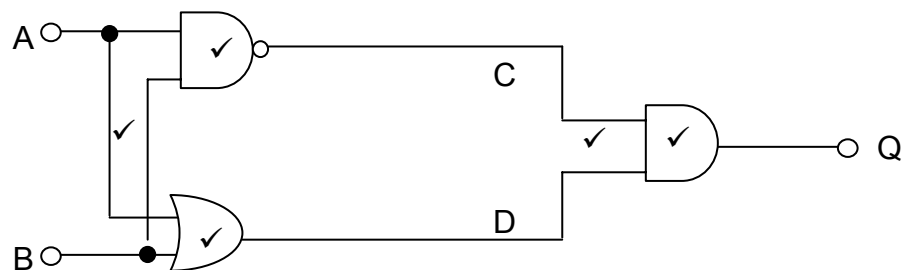

(5 marks)

(b)  $C = \overline{A \cdot B}$  ✓

$D = A + B$  ✓

(3 marks)

(c)  $Q = (\overline{A \cdot B}) \cdot A + B$  (or  $A \oplus B$ ) ✓ ✓

(2 marks)

(question total 10 marks)

1 (a)

A	B	$\overline{A}$	$\overline{B}$	$\overline{A + B}$	A + B	Q
0	0	1	1	1	0	0
0	1	1	0	1	1	1
1	0	0	1	1	1	1
1	1	0	0	0	1	0
		✓	✓	✓	✓	✓

(5 marks)

(b)

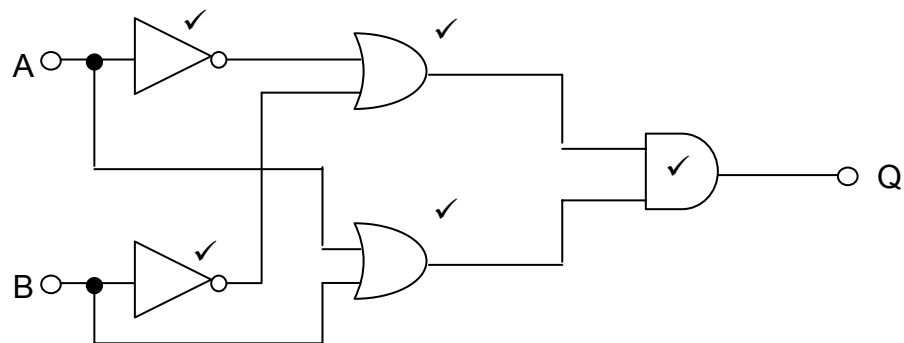

(5 marks)

(c) EXOR ✓

(1 mark)

(Total 11 marks)

- 1 (a)  $C = \overline{A + B}$  ✓  $D = A . B$  ✓
- (b) (i)  $Q = \overline{C + D}$  ✓
- (ii)  $A \oplus B$  or  $\overline{(A + B) + (A . B)}$  ✓✓
- (c)

A	B	C	D	Q	
0	0	1	0	0	✓
0	1	0	0	1	✓
1	0	0	0	1	✓
1	1	0	1	0	✓

- (d)  symbol ✓ labels ✓

**Total – 11**

1 (a)

A	B	C	D	Q
0	0	0	1	0 ✓
0	1	1	1	1 ✓
1	0	1	1	1 ✓
1	1	1	0	0 ✓

(4 marks)

- (b)  $C = A + B$  ✓  
 $D = \overline{A . B}$  ✓ (2 marks)

- (c) (i)  $C . D$  ✓  
(ii)  $(A + B) . \overline{A . B}$  or  $A \oplus B$  ✓ (2 marks)

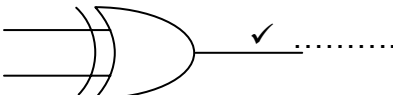
- (d) (i) EXOR ✓  
(ii)  ✓ .....

(2 marks)

**Total 10 marks**

**Boolean (ELE2, Q1, 2008)**

1 (a) E ✓

(b) E.g. There are six occasions when the green light of traffic lights 1 is on and so each of these occasions must be **ORed** together. ✓  
 For each individual occasion, the logic state of the four counter outputs must be **ANDed** together to give logic 1. This means some of the counter outputs must be inverted. ✓

(c) Karnaugh map or Boolean algebra to give  $G = D \cdot \overline{B} \cdot \overline{C}$   
 One mark for each simplification. ✓ ✓ ✓

(d)

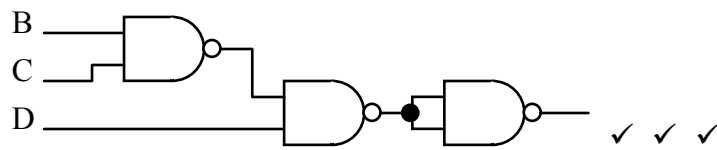

**Total – 9**