



Please write clearly in block capitals.

Centre number

--	--	--	--	--

Candidate number

--	--	--	--

Surname

---

Forename(s)

---

Candidate signature

---

# AS ELECTRONICS

## Unit 2 Further Electronics

---

Thursday 26 May 2016

Afternoon

Time allowed: 1 hour

### Materials

For this paper you must have:

- a pencil and a ruler
- a calculator
- Data Sheet (enclosed).

### Instructions

- Use black ink or black ball-point pen.
- Fill in the boxes at the top of this page.
- Answer **all** questions.
- You must answer the questions in the spaces provided. Do not write outside the box around each page or on blank pages.
- Do all rough work in this book. Cross through any work you do not want to be marked.

### Information

- The marks for each question are shown in brackets.
- The maximum mark for this paper is 67.



J U N 1 6 E L E C 2 0 1

IB/M/Jun16/E4

**ELEC2**

Answer **all** questions in the spaces provided.

- 1 At the correct tension, a cable in a suspension bridge vibrates at a frequency of 120 Hz.

An engineer taps the cable and listens to the sound made as it vibrates. This is hard to hear near noisy traffic. A student designs a system to “listen” to the sound of the cable, but ignore background noise.

A microphone is placed on each side of the cable as in **Figure 1**.

**Figure 1**

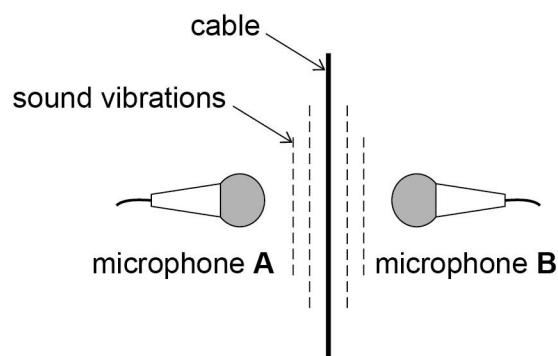

The microphones have a very high output resistance, and the student is advised to connect each one to a voltage follower.

- 1 (a) (i) Complete **Figure 2** to show the circuit for a voltage follower.

Label the input and the output.

[2 marks]

**Figure 2**

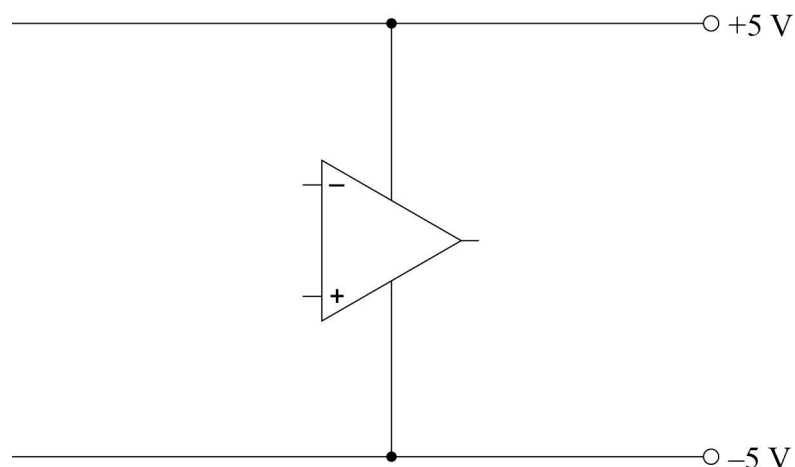

1 (a) (ii) State the voltage gain of a voltage follower.

[1 mark]

---

1 (a) (iii) Explain why voltage followers are used in this situation.

[2 marks]

---



---



---

1 (b) The background noise is picked up by each microphone at the same time, causing identical voltage signals.

Sound from the cable causes opposite voltage signals from each microphone.

The student connects the two output signals from voltage followers into a difference amplifier.

Complete **Figure 3** to show the circuit for a difference amplifier.

[4 marks]

**Figure 3**

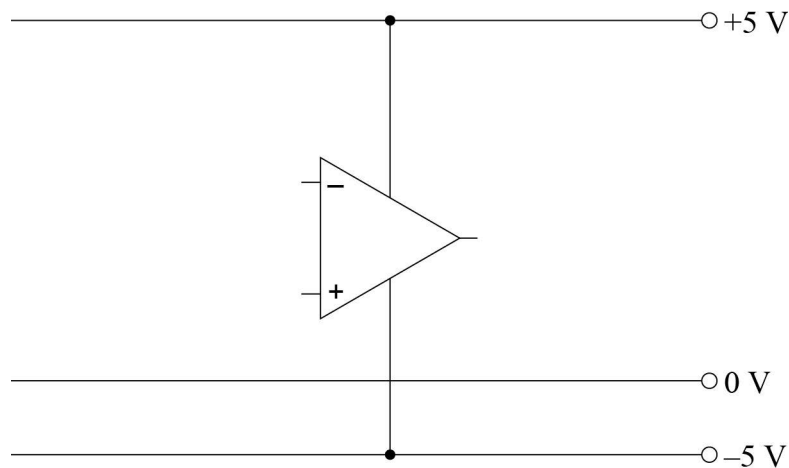

1 (c) The output signals from the microphones are  $+5 \text{ mV}$  and  $-5 \text{ mV}$ . The difference amplifier has a gain of 200.

Calculate the output voltage from the difference amplifier.

[2 marks]

---



---



---



2 A student designs a metronome to help her to keep in time when playing a musical instrument. She decides to use a 555 astable circuit.

2 (a) Complete **Figure 4** for a 555 astable circuit by adding the timing components  $R_A$ ,  $R_B$  and  $C$  and any connections needed.

[4 marks]

**Figure 4**

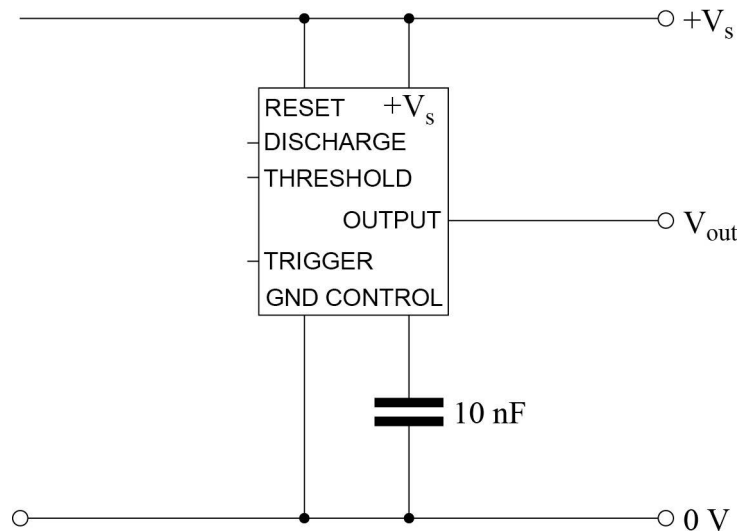

2 (b) (i) The student wants the output to be low for approximately 70 ms. She selects a  $10 \mu\text{F}$  capacitor for  $C$ .

Show that the resistor value needed for  $R_B$  is  $10 \text{ k}\Omega$ .

[2 marks]

---



---

2 (b) (ii) Calculate the resistor value for  $R_A$  needed to make the output high for 430 ms.

[2 marks]

---



---



---



---



2 (c) When the astable output is low, a buzzer sounds.

When the astable output is high, the buzzer is silent.

Complete **Figure 5** to show how the buzzer should be connected to the 555 output.

[2 marks]

**Figure 5**

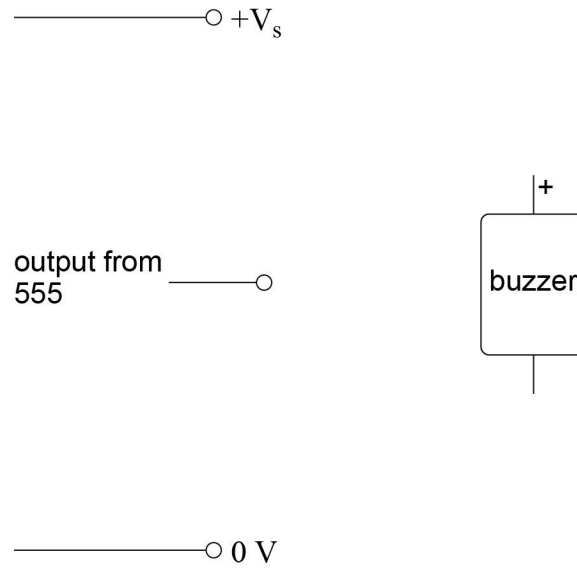

2 (d) Suggest how the student could change the astable circuit to allow her to adjust the beats per minute (bpm) without altering the length of time the buzzer sounds.

[1 mark]

---



---

Turn over for the next question



3 Figure 6 shows a rising edge triggered D-type flip-flop.

Figure 6

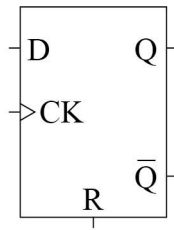

3 (a) Input D is connected to logic 1. The flip-flop is reset so that output Q is 0.

Circle the letter of the timing diagram in Figure 7 that shows what happens when a clock pulse is now applied to the clock input.

[1 mark]

Figure 7

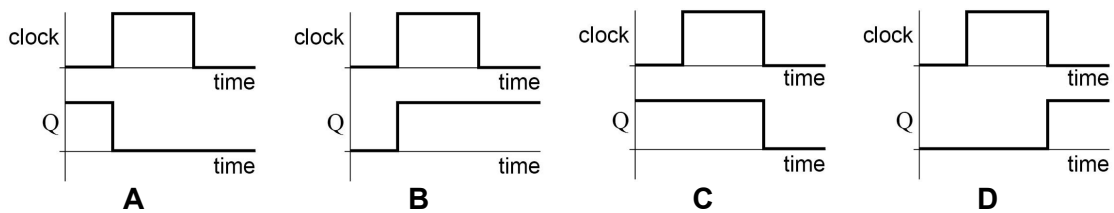

3 (b) Complete Figure 8 to show how four rising edge triggered D-type flip-flops can be connected to form a 4-bit shift register.

Label the serial input to the shift register.

[4 marks]

Figure 8

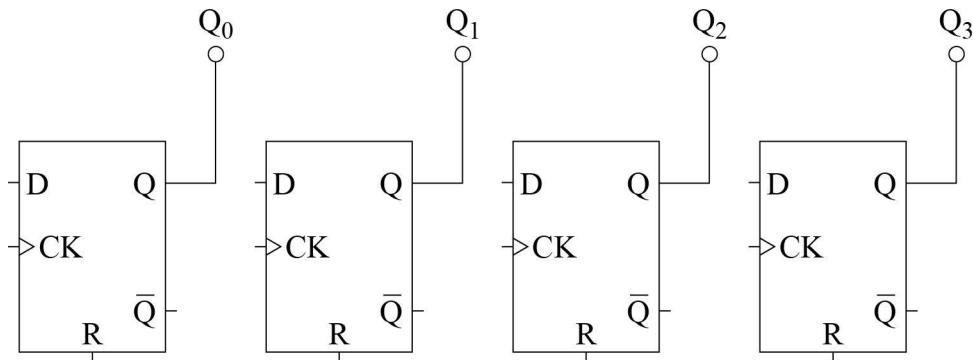

- 3 (c)** The shift register is used as part of a fire exit sign. When the fire alarm is triggered, red triangular LEDs in the sign flash to show the direction to the nearest exit. A rising edge triggered D-type flip-flop is connected to the shift register.

The arrangement is shown in **Figure 9**.

The solid triangles represent the LEDs.

**Figure 9**

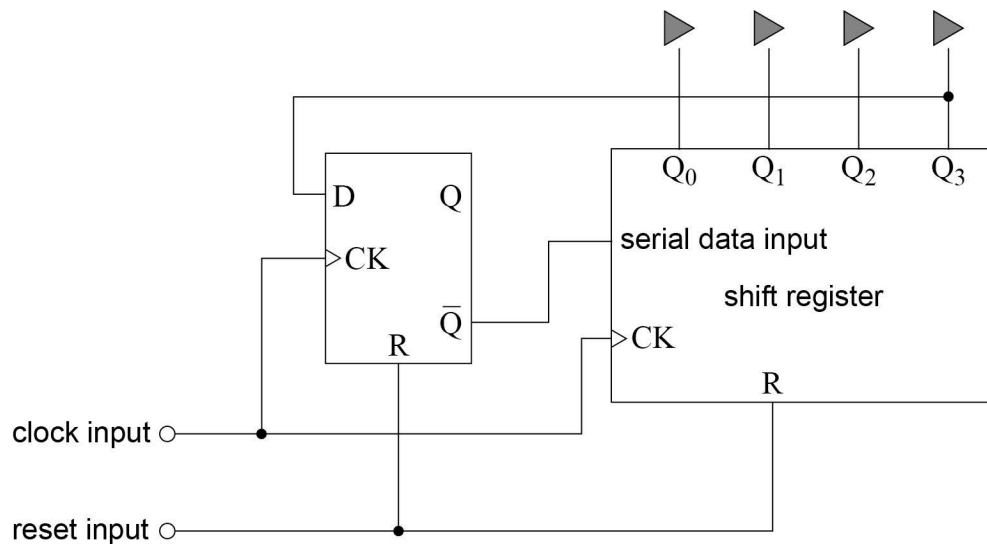

- 3 (c) (i)** When the fire alarm is triggered, the reset input is pulsed to logic 1 and then returns to logic 0.

State, with a reason, the logic state of the serial data input of the shift register.

**[1 mark]**

---



---

- 3 (c) (ii)** Describe the state of the LEDs at this time.

**[1 mark]**

---



---

**Question 3 continues on the next page**



**3 (d) (i)** Clock pulses are now applied to the clock input.

Describe what will happen during the first four clock pulses.

**[2 marks]**

---

---

---

**3 (d) (ii)** Describe the appearance of the fire exit sign as clock pulses continue to be supplied.

**[2 marks]**

---

---

---

11





**4 (a)** An electronics company makes components by winding thin wire into coils.

They develop a machine that displays how many turns of wire have been wound onto a coil.

The number of turns is shown on three seven-segment displays connected to three BCD counters.

Complete **Figure 10** to show how four D-type flip-flops and an AND gate can be connected to form a BCD counter.

Label the input to the counter.

**[5 marks]**

**Figure 10**

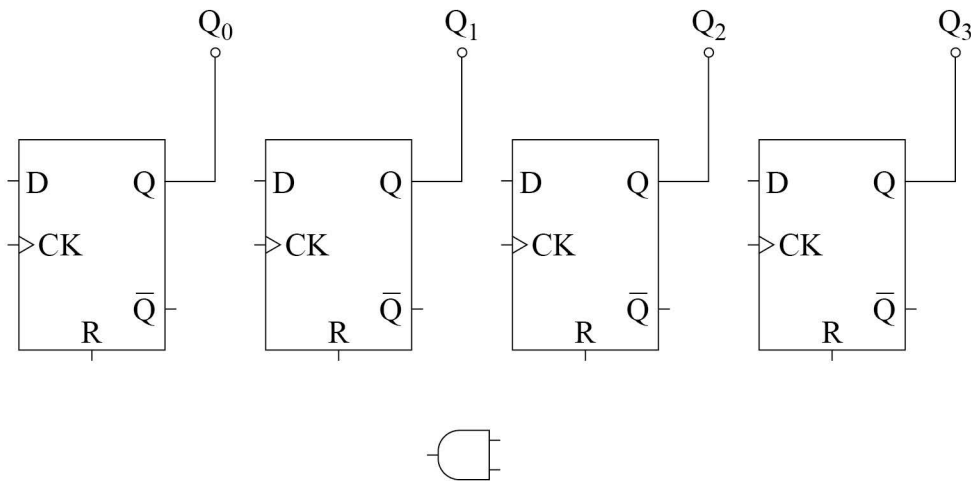

**Question 4 continues on the next page**



- 4 (b) The input to the first BCD counter is from a mechanical switch circuit. The mechanical switch contacts close once per revolution of the coil. **Figure 11** shows the switch circuit and an oscilloscope trace of the signal at the output of the NOT gate.

**Figure 11**

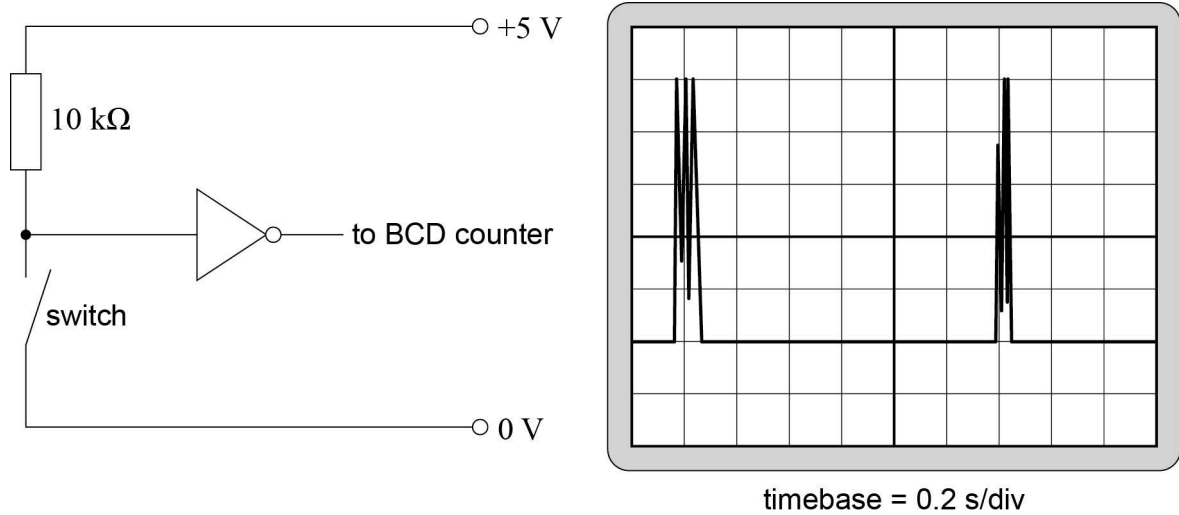

When connected to this switch circuit, the BCD counters do not count smoothly on each revolution of the coil, but increment randomly.

Explain why the counters do not increment smoothly.

**[2 marks]**

---



---

- 4 (c) It is suggested that the problem can be solved by connecting a capacitor across the switch contacts, as shown in **Figure 12**.

**Figure 12**

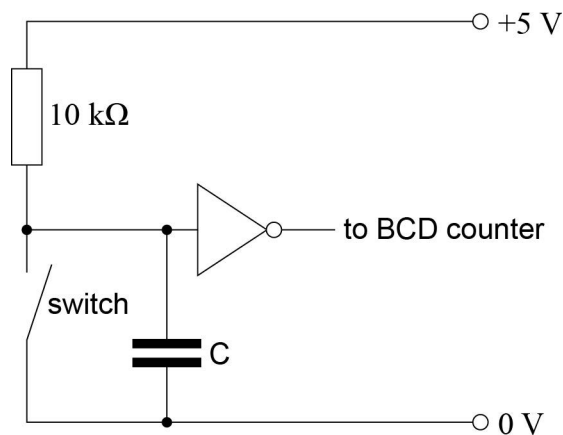

4 (c) (i) Explain why this might solve the problem.

[2 marks]

---

---

---

4 (c) (ii) Estimate, using a calculation, a suitable value for the capacitor by using the oscilloscope trace in **Figure 11**.

[3 marks]

---

---

---

---

12

Turn over for the next question



- 5 (a)** This question is about an amplifier subsystem that is based on a **real** op-amp. The op-amp has a resistance between its input terminals of  $10^{10} \Omega$  and a gain bandwidth product of 1 MHz.

**Figure 13** shows the circuit of the op-amp amplifier subsystem.

**Figure 13**

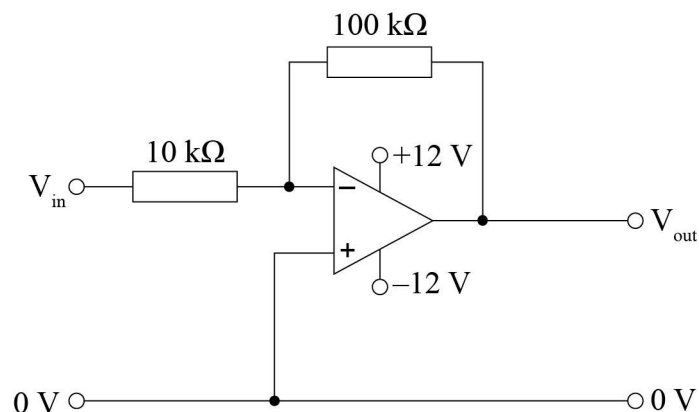

- 5 (a) (i)** Circle the output voltage of this amplifier subsystem when  $V_{in}$  is +0.5 V.

[1 mark]

-5.5 V                      -5 V                      +5 V                      +5.5 V

- 5 (a) (ii)** Circle the most likely maximum frequency for which this amplifier subsystem will have its theoretical gain.

[1 mark]

1 kHz                      10 kHz                      100 kHz                      1 MHz

- 5 (a) (iii)** Show that there is an input current to the amplifier subsystem of  $50 \mu\text{A}$  when  $V_{in}$  is 0.5 V.

[2 marks]

---



---

- 5 (a) (iv)** Describe where the input current flows in this amplifier subsystem.

[2 marks]

---



---



**5 (b)** The amplifier subsystem is adapted to detect when the flame is burning in a gas central heating boiler. A metal electrode connected to +50 V is positioned in the flame.

The arrangement is shown in **Figure 14**.

**Figure 14**

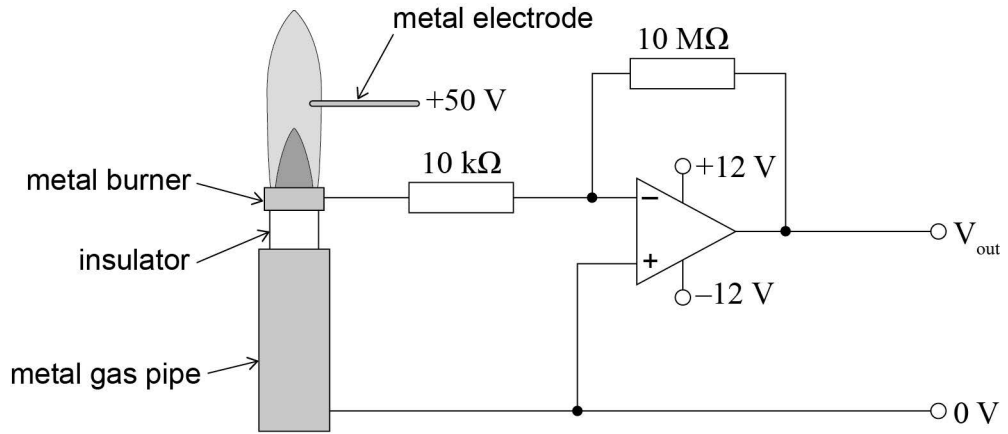

When the gas is burning, a current of  $1 \mu\text{A}$  passes through the flame into the amplifier subsystem.

**5 (b) (i)** Estimate the resistance of the gas flame.

**[2 marks]**

---



---

**5 (b) (ii)** Estimate the output voltage from the amplifier subsystem.

**[3 marks]**

---



---

11
----



6 **Figure 15** shows the circuit diagram for a push-pull amplifier.

**Figure 15**

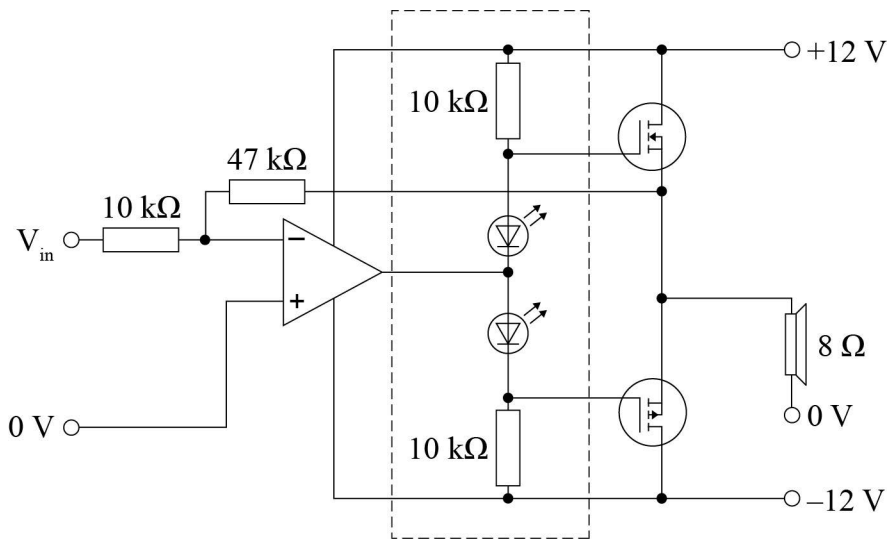

6 (a) Estimate the voltage gain of the amplifier, stating any assumption that you make. **[3 marks]**

---



---



---



---

6 (b) Explain the purpose of the components in the dotted box in **Figure 15**. **[2 marks]**

---



---



---



- 6 (c)** A student experiments with this amplifier to create a control system. He replaces the loudspeaker with a motor and gearbox, and adapts the circuit as shown in **Figure 16**.
- The output of the gearbox is connected to the spindle of a variable resistor, VR.
- The variable resistor rotates as the motor turns.

**Figure 16**

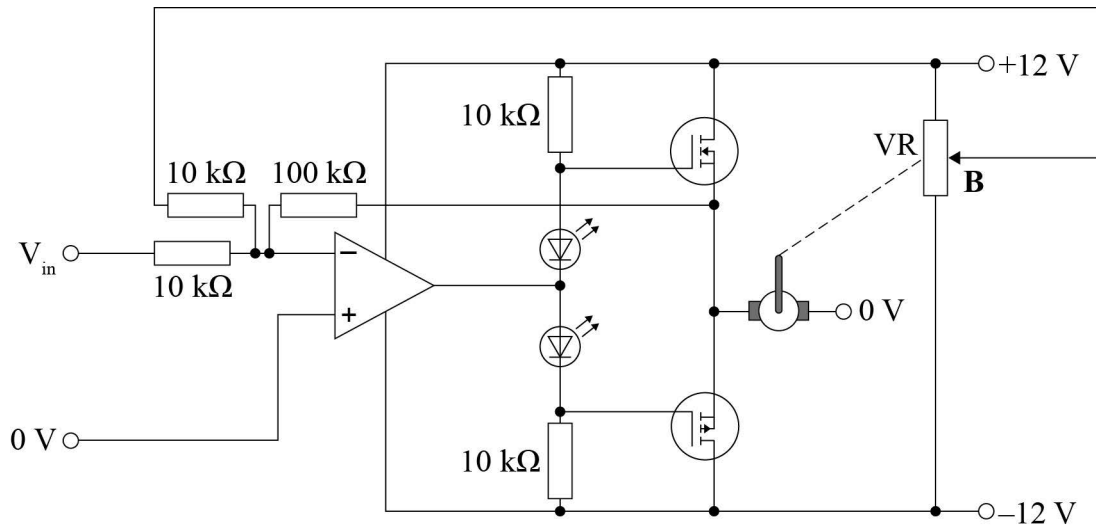

- 6 (c) (i)** Tick (✓) **one** box next to the correct statement.

**[1 mark]**

- The op-amp circuit has been changed to form a voltage follower.
- The op-amp circuit has been changed to form a difference amplifier.
- The op-amp circuit has been changed to form a summing amplifier.
- The op-amp circuit has been changed to form a non-inverting amplifier.

**Question 6 continues on the next page**



**6 (c) (ii)** When  $V_{in}$  is 0 V, the motor is stationary and the voltage at **B** is 0 V.

When  $V_{in}$  is set to +2 V, the motor starts to rotate and the voltage at **B** starts to decrease.

Estimate the output voltage from the amplifier when  $V_{in}$  is initially set to +2 V.

**[2 marks]**

---

---

**6 (c) (iii)** Describe how the system will behave if the input remains at +2 V.

**[3 marks]**

---

---

---

---

---

11

**END OF QUESTIONS**

**Copyright Information**

For confidentiality purposes, from the November 2015 examination series, acknowledgements of third party copyright material will be published in a separate booklet rather than including them on the examination paper or support materials. This booklet is published after each examination series and is available for free download from [www.aqa.org.uk](http://www.aqa.org.uk) after the live examination series.

Permission to reproduce all copyright material has been applied for. In some cases, efforts to contact copyright-holders may have been unsuccessful and AQA will be happy to rectify any omissions of acknowledgements. If you have any queries please contact the Copyright Team, AQA, Stag Hill House, Guildford, GU2 7XJ.

Copyright © 2016 AQA and its licensors. All rights reserved.

