

ResultsPlus

Examiners' Report June 2009

GCE

GCE Economics and Business 6EB01 / 6EB02

ResultsPlus
Helping you to raise attainment
www.resultsplus.edexcel.com

Edexcel is one of the leading examining and awarding bodies in the UK and throughout the world. We provide a wide range of qualifications including academic, vocational, occupational and specific programmes for employers.

Through a network of UK and overseas offices, Edexcel's centres receive the support they need to help them deliver their education and training programmes to learners.

For further information, please call our GCE line on 0844 576 0025, our GCSE team on 0844 576 0027, or visit our website at www.edexcel.com. If you have any subject specific questions about the content of this Examiners' Report that require the help of a subject specialist, you may find our **Ask The Expert** email service helpful.

Ask The Expert can be accessed online at the following link:

<http://www.edexcel.com/Aboutus/contact-us/>



ResultsPlus is our unique performance improvement service for you and your students.

It helps you to:

- **Raise attainment** - by providing in-depth analysis of where your class did well and not so well, enabling you to identify areas to focus on/make improvements.
- **Spot performance trends** at a glance by accessing one-click reports. You can even choose to compare your cohort's performance against other schools throughout the UK.
- **Personalise your students' learning** by reviewing how each student performed, by question and paper you can use the detailed analysis to shape future learning.
- **Meet the needs of your students on results day** by having immediate visibility of their exam performance at your fingertips to advise on results.

To find out more about ResultsPlus and for a demonstration visit <http://resultsplus.edexcel.org.uk/home>

June 2009

Publications Code US021161

All the material in this publication is copyright
© Edexcel Ltd 2009

Contents

Economics and Business 6EB01 / 6EB02

6EB01

General Comments 2

Section A 3

Section B 5

6EB02 6

General Comments 6

Section A 6

Section B 13

Statistics 22

6EB01

General Comments

Overall candidates' performance on this paper showed a sound grasp of business/ economics concepts and theory together with a good understanding of business behaviour. Answers suggested that candidates had, on the whole, been better prepared than in January for topics that in some case were quite a departure from traditional GCE specifications in Business Studies/Economics and Business, for example value added and enterprise capability.

Section A

As with January, examiners were exposed to a full range of approaches, from what appeared to be candidates carefully coached how to handle supported multiple choice questions, to others where there still appeared to be little evidence of preparation. At GCE level, the use of supported multiple choice questions enables an awarding body to test more than straightforward recall. Indeed, the three explanation marks proved good discriminators, particularly for questions 1, 2, 3, 4, 6 and 8, which required candidates to explicitly analyse and evaluate.

Question 1

The majority of candidates answered this question correctly, though some explanations in part (b) often lacked clarity. Resilience in some cases was a characteristic clearly not understood, despite the specific reference to this in the Specification in section 1.3.1, page 18. Better answers tied their response to characteristics of successful entrepreneurs and to the stem, ie the television show 'The Apprentice'.

Question 2

Clearly a number of candidates misread the phrase in D 'to reduce capital' as 'to release capital' and so went on to explain that this was the correct response because selling a business will provide its owners with finance. Those who correctly identified A as the correct response explained that this was most likely given that owning your own business will be very time consuming and involve a great deal of decision-making and responsibility which the owners Mike and Claire may have wanted to relinquish.

Question 4

Candidates generally struggled with the financial/economics concepts; few used an explanation of demand theory. Stronger candidates for this particular question were able to explain that if the price of bread increases, demand will fall. This will result in a loss in revenue which could lead to the bakery closing down if overheads are not covered. Close substitute products like pasta or rice may face an increase in demand as a result of the increase in bread prices continuing. Again, better candidates were able to dismiss one distracter such as if overheads decrease then the bakery should be more profitable and so would stay open rather than close.

Question 5

On the whole, this question was tackled easily by candidates. Most were generally clear on the contrast between primary and secondary research and the better candidates applied this grasp to the Social Trends context. It was expected that in part (b) to gain full marks candidates were able to say that the census is not collected by a specific business or user but by the government. Taking part (a) and (b) together, this was the best answered supported multiple choice question.

Question 6

A question answered reasonably well by candidates, with many recognising that lower interest rates would make borrowing more attractive for the small electrical retailer to purchase fixed assets like shop fittings or a delivery van, for example. Some candidates focused their answers on the likely consequences for *customers* of electrical products and so argued that their borrowing would increase and so identified A 'spending on stock increases' as the correct answer. In such cases an analytical mark was awarded in part (b) of the question.

Question 7

This was a very accessible question, generally answered well by most candidates. Many showed a good knowledge of the contents of business plans and cash flow forecasts, and in many cases dismissed other options easily and accurately.

Question 8

Although the majority of the candidates chose the correct option of part (a)(response B), the quality of responses in part (b) was poor. There is still a widespread incorrect assumption that market mapping is to do with location. Many candidates chose to list the options and not use them, for example 'Evaluating competition, market mapping and considering competitive advantage are all part of positioning, estimating profitability is not', which brings in no additional knowledge, understanding or application. Good answers argued that estimating profitability was something a business did either after the business was set up or after the positioning was analysed.

Section B

The Shivani Patel/Fold case study appeared to be accessible to most candidates. Given the Edexcel support material and guidance provided to centres for this Unit through 'Getting Started' and other sources; it is clear that candidates were generally well prepared for the topics which featured such examples as exchange rate movements and factors which affect turnover and operating profit. One or two centres have commented that there may be a time issue with this paper, on the basis that candidates did not complete this section of the paper. Examiners did not find this to be a significant number of candidates.

Question 9

This was answered well. Students applied their responses clearly to the context. In most cases marks of 4 were awarded, with analysis being the most likely marks to have been missed. Candidates need to explain why moving to the Fold might increase turnover, for example.

Question 10

Candidates answered this well, with a good understanding of the difference between turnover and profit. In the main, a mark of 2 or 3 was awarded. The fourth mark was generally not achieved due to a lack of application in answers.

Question 11

There was a big divide between those who knew what 'added value' was and those that did not. Those that did tended to answer in context quite well and so went on to achieve 5 or more marks, whereas others were stuck at very low levels. Furthermore, even strong answers tended to be one-sided, with candidates assuming that 'might be particularly important' meant that it was important.

Question 12

Despite the dangers of candidates confusing appreciation with depreciation, a large number appeared to have understood correctly that importers would benefit. A large number of good marks were limited by a lack of application to Fair Trade/Co-op and also an assumption that evaluation came from looking at the effects on exporters, rather than looking at how Fair Trade/Co-op may actually not be affected by the exchange rate change because, for example, quality may be more important than price.

Question 13

A large number of candidates achieved good marks of 8+, partly because of the way the mark scheme was ordered. Many candidates carefully analysed the effects on at least one business and were able to apply their answers well. There was a feeling that the question perhaps limited the ability of more able candidates to achieve marks significantly higher than the 'average' because of this. The addendum to the mark scheme helped to open up the evaluation marks to a wider number of candidates.

6EB02

General Comments

This was the first paper for the new specification and overall candidates' performance showed a sound grasp of business and economic concepts. Answers suggested that candidates on the whole had been well prepared for this paper. There appeared to be use of precise Economic and Business terminology throughout Section A and B. The best students demonstrated excellent application of their knowledge to the precise question set, while the weakest students attempted questions from a 'common sense' approach rather than demonstrating any economic and business concepts. The examination paper required candidates to apply their understanding; good students did this well with clear development of points. On a general note, there appeared to be confusion between 'monopolistic' and 'monopoly' and the use of words such as 'huge' and 'massive' are to be avoided. Examination timing skills appeared to be very good as a whole.

Section A

Examiners encountered a full range of approaches, from what appeared to be candidates carefully prepared on how to handle supported multiple choice questions, to others where there still appeared to be little evidence of preparation. At GCE level, the use of supported multiple choice questions enables the testing of more than straightforward recall. The three explanation marks in part (b) of the supported multiple choice questions proved good discriminators which required candidates to explicitly analyse and evaluate.

Advice on how to improve performance on Section A



ResultsPlus

Examiner Comments

For questions which require judgement or justification, indicated by the command 'least likely'/'most likely', it is advised that, in order to score the full 3 marks in part (b), candidates not only explain why their answer is correct, but also choose one of the incorrect answers and say why this is incorrect. Many candidates simply did not write enough in part (b) to score the full 3 marks. Many answers were not detailed enough or were simply repetition of their chosen answer. This technique will allow candidates to score up to 2 marks for discounting why the other options are incorrect. This does have to be balanced with overall timings for the paper but could lift a candidate's score by 6 marks if done correctly on all supported multiple choice questions.

Question 1

The majority of candidates answered part (a) correctly and in part (b) could explain the link between a fall in the price of a complementary good and DVD players. Many candidates contextualised their answers and the better candidates developed their answers to show how the two products were linked. Many candidates did gain marks by discounting why one of the other options did not lead to an increase in demand for DVD players.

In this case a complementary good is would be DVD's, therefore if there was a fall in price for DVD's, and they became cheaper, people would go out and buy the DVD's and would therefore need a DVD player to play them off. If there was a fall in incomes or a fall in population size, this would more than likely decrease the demand for DVD players as people may not be able to afford the product and there may be less people to actually buy it.



This candidate gets the 3 marks by explaining why C is correct and then goes on to discount two other options and why they are incorrect. It is not necessary to discount all other options and candidates can only score a maximum of 2 marks on part (b) if they take this route.

Complementary goods are goods that are used alongside each other. A fall in price of a good will bring about an increase in demand for the same and its complement.

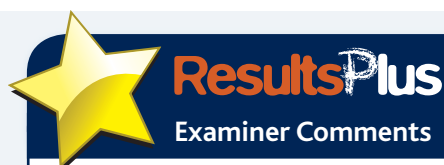

This candidate scored 2 marks because it is not in context and there is no link to DVD players. It is essential that candidates do contextualise their answers and fully develop their answers in order to gain the full 3 marks for part (b).

Question 2

For this question, there was a wide range for answers for Part 2(a) with many candidates thinking that there would be low prices due to high competition between the banks. Many candidates did not identify that there would be in fact low competition due to the high barriers to entry in the banking industry. Better candidates could give examples of barriers to entry and show how these do in fact lead to high profitability and high prices due to a lack of choice. On the whole many candidates did not contextualise their answers and did not link to the question stem which clearly referred to the banking industry.

(b) Explain why this answer is correct.

(3)

THE HIGH BARRIERS TO ENTRY WILL RESULT
IN THERE BEING LOW COMPETITION DUE TO THE
LARGER MORE ESTABLISHED BANKS HAVING A
GREATER REPUTATION. ANOTHER REASON FOR THE LOW
COMPETITION IS THAT ONE OF THE HIGH BARRIERS WILL
BE START UP COSTS AND THEREFORE NEW BANKS WILL NOT
BE ABLE TO AFFORD THIS.



ResultsPlus

Examiner Comments

This response scored 3 marks because it is in context and refers to larger established firms having greater reputation and difficulties in new banks entering due to start up costs. The candidate clearly understands what a barrier to entry is and how this has restricted competition.

Answer

D

(b) Explain why this answer is correct.

(3)

In an industry such as banking which has high barriers to entry, there will be low competition as it is very hard for a company to enter the market because a small amount of organisations dominate the market often due to economies of scale.

**ResultsPlus**

Examiner Comments

This candidate scored 2 marks for demonstrating that economies of scale could be a barrier to stop new entrants in the banking market. Application could have been better with examples from the banking industry to support this response.

Question 3

Many candidates easily picked up 1 mark for part 3(a) and could justify why a bus company would be least likely to suffer a fall in sales. Better candidates could use economic/business terminology throughout their answer such as buses being an 'inferior good' and could link the other options to YED. It is worth noting that many candidates just made general observations as to a bus 'being cheaper' than a car without demonstrating economic and business terminology. It is essential that candidates demonstrate the relevant economic and business theory in order to access the higher marks. General observations will not score highly.

Question 4

The vast majority of candidates scored 1 mark for 4(a) and correctly identified that product differentiation would not be found in a perfectly competitive market. This question did not have a context in the stem of the question so this did hinder less prepared candidates. Many candidates recognised that 3 of the options were features of a perfect competitive market and were able to dismiss them in order to pick up 2 marks. It is essential that candidates do fully explain the distracters rather than just listing them. Many candidates used their own context to explain homogenous goods.

In a perfectly competitive market like the agriculture and wheat market, there are many buyers and sellers due to the similarities in products. All products are very similar e.g. the wheat market all wheat is the same. This is why there is not much product differentiation. Low costs and low competition reduce barriers to entry unlike in monopolistic markets. Everyone also has perfect product knowledge, which is why the products do not differentiate.



ResultsPlus

Examiner Comments

This candidate has used a combination of explaining why some of the options are incorrect as well as using their own example of agriculture to demonstrate why product differentiation is not found in a perfectly competitive market. This is a good example of a well developed answer and scored 3 marks.

(3)
It is not B as in a perfectly competitive market there are many sellers to make an equal market share and many buyers.
It is not C as by having no barriers to entry, it means that any firm can enter the market unlike an imperfect competitive market which has duopolies/monopolies which ~~dominate~~ dominate market share, making it hard to enter. (Total for Question 4 = 4 marks)

**ResultsPlus**

Examiner Comments

This scores 2 marks by discounting the other options (with some development rather than a list of the options). It does not make any reference to why the answer is product differentiation so a maximum 2 marks can be awarded.

Question 5

This was another question which did not provide a context so made it harder for candidates to structure their responses. Many candidates incorrectly thought that a fall in interest rates was the correct answer. However others gained marks in part (b) by recognising that a rise in unemployment and a fall in imports were more likely to occur in a recession rather than a boom phase of the economic cycle.

Question 6

This question was poorly answered in part (b) with many only scoring 1 mark for showing some understanding of the consequences of increased consumer knowledge. Many candidates did correctly identify that Option A (Price) was unlikely to increase due to an increase in consumer knowledge but clearly candidates did not understand why this was the case.

If the consumer has increased knowledge about all then companies will not be able to increase their price. The quality and choice of products as well as standards of service need to increase however because the customer knows what value for money is and which businesses are better than others.



ResultsPlus

Examiner Comments

This answer shows some understanding of consumer knowledge and explains the consequences of this in terms of how the business is likely to react to this. The answer does not say why companies will not be able to increase the price. It scored 2 marks.

When there is an increase in consumer knowledge it forces businesses to ensure that the product and service they are offering has a competitive advantage over others, this may lead to adding value to their product and/or service by improving the quality and range of products available to ensure there is no decrease in demand for their product.



ResultsPlus

Examiner Comments

This is another example of a response which scored 2 marks for part (b). This candidate did correctly identify Option A for part (a) and then gained the other 2 marks for discounting the other choices (they actually cover all 3 options) but again they do not make any reference to why the price would decrease just why the others would increase.

Question 7

This was poorly answered with many candidates simply stating that demand was 'how many people want a product or service'. It is advisable that candidates do provide a relevant example to lift a vague or incomplete definition to 2 marks.

Section B

This section of the examination paper was based on 2 pieces of evidence on the mining industry. Evidence A was focused on the tyre shortage whilst Evidence B was about a proposed merger between BHP Billiton and Rio Tinto. Candidates did not need to know specific information about these businesses or the mining industry as a whole and both pieces of evidence gave candidates enough information to apply the economic and business concepts covered in Unit 2b.

Advice on how to improve performance on Section B:



ResultsPlus

Examiner Comments

Many examiners commented on the lack of analysis and evaluation on the 8+ marks and felt that time spent on these skills would improve candidates' overall performance. Candidates should be familiar with the command words used and provide a balanced response to questions with the command words 'Assess' or 'Evaluate'. Precise use of economic and business terminology will also improve marks as many responses were answered from 'common sense' approach. Well structured responses with good use of terminology will always score highly.

Question 8

Some candidates misread the evidence and moved the supply curve inward which would suggest tyre firms leaving the industry when in fact they are working flat out to meet current demand (and failing). This should have alerted candidates to excess demand and therefore an outward shift of the demand curve causing a movement along the supply curve and showing an increase in price and to an extent quantity. The split of marks for this question was 4 marks for the diagram and 2 marks for the written explanation as to why the price of truck tyres has increased so much. This allowed some candidates to score 1 or 2 marks even with an incorrect diagram.

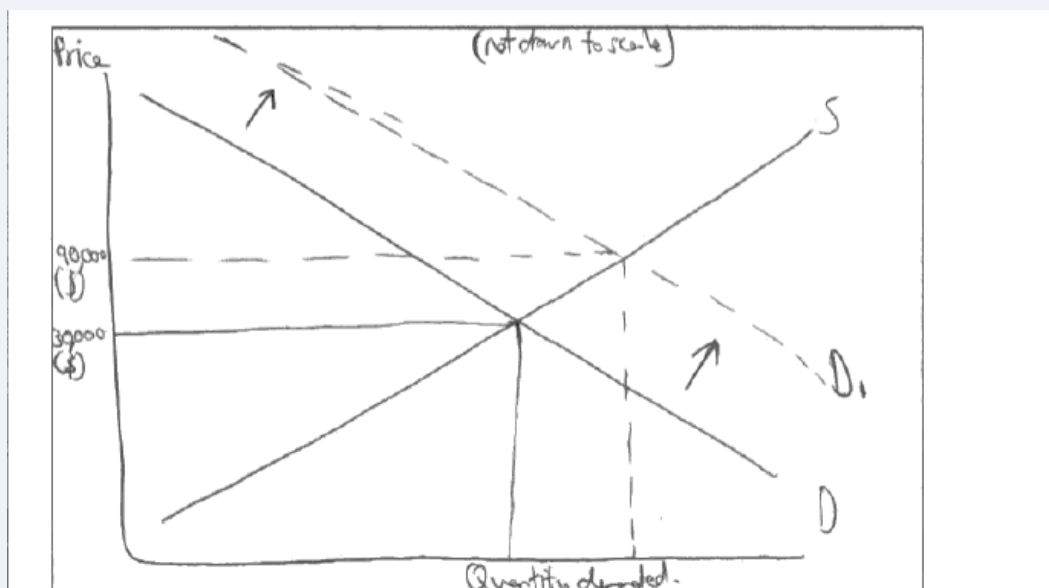

From this diagram we can see that due to increased demand the price of tyres has increased. As supply has not moved, but demand has increased it would cause an increase in price as there is less supply. Though not accurately drawn, the Demand Line marked (D) would be more elastic as the price has increased so fast, and so it would be more vertical, and ^{more upward} ~~more~~ price would ^{rise} as demand increases.

(Total for Question 8 = 6 marks) **6**



ResultsPlus

Examiner Comments

This has a correctly labelled diagram with an outward shift in the demand curve and a contextualised written explanation as to why the price of truck tyres has increased. The candidate scored six marks.

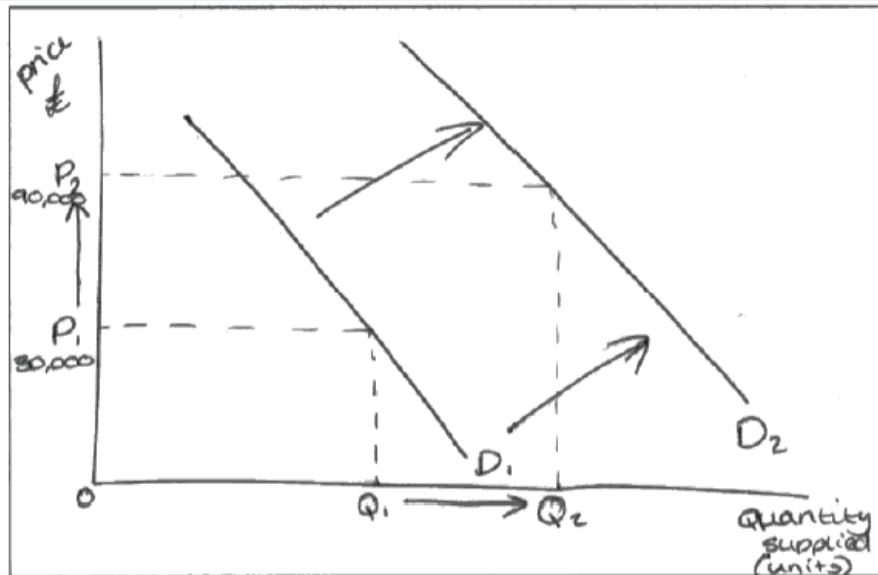

As the mining industry has got ever-increasing demand, they need to be able to mine quicker and easier, doing this they would need more 'dump trucks'. This then increases the demand for tyres. As the tyres are so specialised, more money is needed to make them so as demand increases, the price increases.

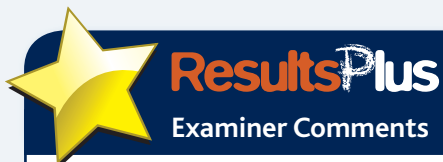

Examiner Comments

This does have an outward shift in the demand curve showing an increase in price and quantity demanded but lost 2 marks for the diagram due to there being no supply curve. There was some merit in the written explanation underneath the diagram and it was in context therefore a total of 3 marks for this response.

Question 9

A number of candidates did not understand what would happen to tyre prices in the future. Many did not understand the concept of long run and simply copied out chunks of the evidence. Better candidates did appreciate that due to the profit signalling mechanism that new firms might enter the market or that current suppliers would expand capacity to take advantage of the situation.

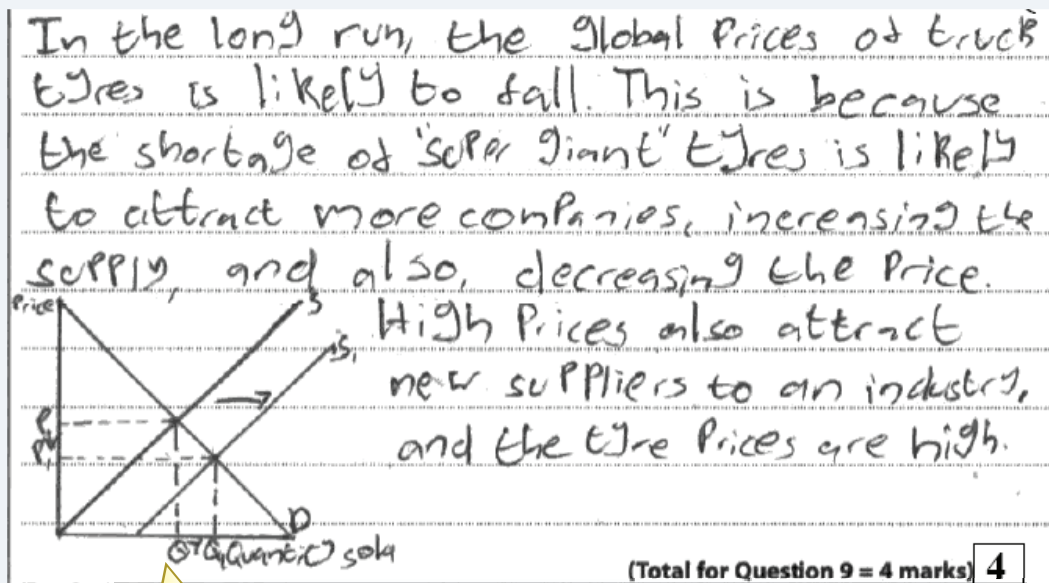

ResultsPlus

Examiner Comments

This is an example of an excellent full marks answer with a demand and supply diagram to illustrate (although this was not needed). This response answers the question set and is well structured.

Question 10

There were some good answers to this question but far too many did not appreciate the relationship between BHP Billiton and Rio Tinto and why they would want to merge in the first place. Better answers were well structured with candidates clearly identifying the reasons for the merger then further developing these reasons with some awareness of consequences. The reasons for the merger ranged from increased market share to elimination of competition. Less able students did tend to repeat themselves and this therefore restricted their overall mark for this question. Surprisingly economies of scale as a reason for the merger were too often ignored and the main focus tended to be on monopoly power and the profits which can come from this position. Again, candidates lost application marks due to responses being generic and not applied to BHP Billiton and Rio Tinto.

Question 11

There were some good answers for this 4 mark question but many candidates did not appreciate the relationship between the steel makers and BHP Billiton/Rio Tinto. Many thought that the steel makers were rivals rather than customers of the mining companies. Candidates also did not appreciate that the price of iron ore could rise and output fall with the merger of two major suppliers of iron ore. This was a question demanding application of knowledge of problems associated with monopoly and candidates often did not apply their knowledge.

steel makers would be alarmed as they would suffer in the long run. The case study states that they would have to rely on them to supply them with iron-ore and would reduce bargaining power for steel makers. This could lead to the buyers not being able to make as much profit as before as they would need to pay more for the inputs and would have to increase their output price which could lead to a fall in demand and diseconomies of scale. (Total for Question 11 = 4 marks) 3



ResultsPlus

Examiner Comments

This candidate has written in context and has demonstrated an understanding of the consequences of the proposed merger to the steel makers. The response scored 3 marks.

Steel makers will be alarmed because the merge would 'significantly reduce the bargaining power of steel makers'. This is because they 'rely on supplies of iron ore'. The merge would mean steel makers having to pay a higher price as there would probably be no alternative resource for them.



ResultsPlus

Examiner Comments

The first part of the response was simply copied from the evidence so scores no marks. There is some merit in the last sentence where the candidate identifies the consequences of the proposed merger for the steel makers. The candidate scored 2 marks.

Question 12

Candidates were able to make sensible suggestions as to options open to businesses facing rising costs but then unfortunately did not analyse consequences or assess their quality and likely success of the action. Many candidates proposed increases in prices without mentioning elasticity or the appearance of substitutes or the action of competitors. This question was not done particularly well and perhaps only the best candidates were able to access the higher marks. This is an 'Assess' question and candidates should have been prepared to evaluate their suggestions. Again, application to the context was ignored by some candidates who made suggestions which were not suitable for a mining company and made generic statements regarding reducing costs.

Another option would be to rise the price of the iron ore in order to ~~use~~ cover the increasing costs. This would mean that they would still make the same amount of profit by simply raising the prices. This however may reduce demand and they may lose customers to other cheaper rivals. But, in this highly demanding market consumers may be forced to ~~use~~ pay the higher price due to a lack of choice from other companies.



ResultsPlus

Examiner Comments

This response clearly identifies a strategy to reduce rising costs (increase the price of iron ore) and then explains how this would maintain profit. The candidate then does evaluate this option and considers the impact on demand from increasing the price.

Question 13 - Overview

This question demanded detailed evaluation of the merger on both shareholders and employees. In order to access the higher marks, candidates must be prepared to evaluate and they must understand what the command word is asking them to do. This was an evaluative question yet many candidates failed to comprehend this and wrote very good answers without any attempt at evaluation or judgement. This therefore limited the vast majority of candidates to Level 2. Centres do need to ensure that their candidates are fully aware of the command words and what is required for an evaluation question.

Question 13(a)

This was not as well tackled as 13(b) with most candidates only seeing the positive impact on shareholders through increased share prices and dividends. Better candidates could use the concepts of diseconomies of scale and loss of control/ownership to balance their answers. This question was better contextualised by candidates who regularly referred to the synergistic benefits of the two mining companies merging.

The merger would have a mix of effects on shareholders in both companies. To start, they will now each own a smaller percentage of the new business so they will therefore have less power and less say. On the other hand, the merger would be making a combined profit, so shareholders could quite possibly receive a larger dividend.

**ResultsPlus**

Examiner Comments

This is an extract showing some evaluation. It does lack application and would have benefited from references to the actual named businesses in the evidence but it does show an evaluative element not seen in most responses. The candidate scored 5 marks for 13(a).

Question 13(b)

Candidates performed better on 13(b) than on 13(a). Those who could see that a merger could affect employees both positively and negatively could access evaluation marks. Many did focus just on the negatives and that due to a duplication of resources many employees (mainly in management positions) could face redundancy. Candidates identified motivational problems and culture clashes of the two businesses. Better candidates did contextualise their responses and did focus their answers on BHP Billiton and Rio Tinto. Many read as generalised answers which could have been talking about any merger and it is essential that candidates do apply their answers to the context set.

The merger would have a mix of effects on shareholders in both companies. To start, they will now each own a smaller percentage of the new business so they will therefore have less power and less say. On the other hand, the merger would be making a combined profit, so shareholders could quite possibly receive a larger dividend.



ResultsPlus

Examiner Comments

This is an extract showing how employees will be both positively and negatively affected by the merger. Again, application is lacking but the candidate does evaluate the impact on employees with a final conclusion. The candidate scored 6 marks for 13(b).

Statistics

	Max mark	A	B	C	D	E
6EB01 Econ.& Bus.Studies 1	70	46	42	38	34	31
6EB02 Econ.& Bus.Studies 2	70	42	37	32	27	23

Further copies of this publication are available from
Edexcel Publications, Adamsway, Mansfield, Notts, NG18 4FN

Telephone 01623 467467
Fax 01623 450481
Email publications@linneydirect.com
Order Code US021161 June 2009

For more information on Edexcel qualifications, please visit www.edexcel.com/quals

Edexcel Limited. Registered in England and Wales no.4496750
Registered Office: One90 High Holborn, London, WC1V 7BH

Ofqual



Llywodraeth Cynulliad Cymru
Welsh Assembly Government

