

Website Exemplar

GCE D&T Resistant Materials.

Unit: 6RM01.

Topic: Pen.



T

GCE in Design Technology

(AS) Product Design – Resistant Materials Technology

Unit 1 – Portfolio of Creative Skills (6RM01)

Product Investigation

Pen Introduction - Pilot G2 gel pen

The product which I have chosen to work on is the Pilot G2 gel pen. This pen is made by the Japanese company Pilot Corporation, which is both well established and selling its products throughout the world. The G2 gel pen model has been in production for over a decade and its design has been unchanged due to its success. The reasons for its success are its low price, yet high in both writing and manufacture quality. It is also one of the cheapest pens to feature a rubber grip.

The company was founded in 1918 and has since remained as one of the top pen producers. It has produced a very long line of pens, and has learnt from each generation of pens in order to perfect the next. The pens it produces 'come in a variety of types to suit everyone's needs. Things like the rubber grip have been developed to aid the users comfort, while the thicker shape also helps with ergonomics.

#5 This is the second part of the pen casing; it also contains the housing for the retracting mechanism, as well as holding the top clip in place. It is made from polystyrene, as it provides a clear finish and is easy to injection mould.

#3 The ink cartridge contains the ink, has a lid at one end and the ball point in its stainless-steel casing at the other. The ink itself is kept in place by a thick liquid that moves down with the ink, but stops it from flowing back out the cartridge.

#1 This is the grip of the pen. It is one half of the pen casing and features a curving end, the rubber grip and a thread on the other end to which screws into the other half of the casing.

The pen I am using is a gel based pen. The gel used has been developed as an alternative to ink and has a number of advantages over traditional ink. The retractable mechanism that is used has been redesigned many times before the one used in this pen. The introduction of a rubber grip is recent and is still not found on many pens today. This increases the ergonomics of the pen, making it easier for the user to write with. This pen is aimed at a very broad market, advertised as a high quality, cheap pen. Its selling point is value; the rubber grip and the retractable tip give it more value than cheaper pens that have a simple lid, while having similar quality of writing as specialist pens from companies such as Faber-Castel and Mont Blanc.

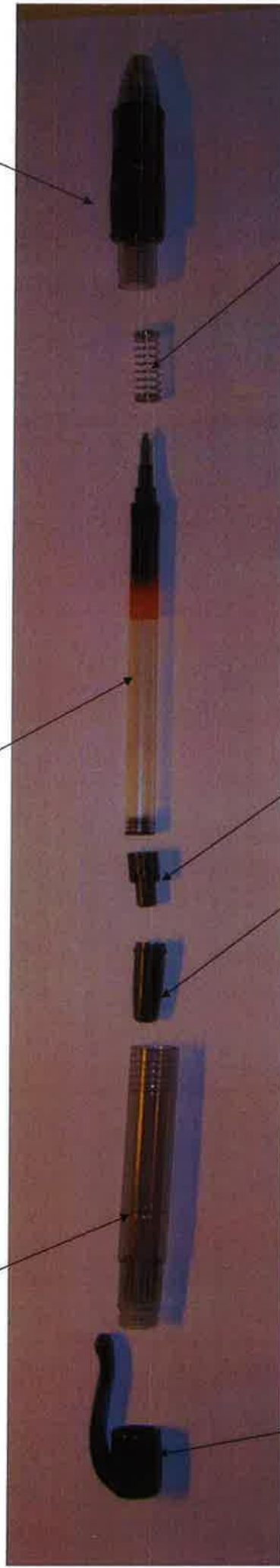

#6 This is the last piece of the pen. It has a clip which can be used to attach the pen to pockets, and it also provides a nice finish to the end of the casing. Most likely made out of phenolic resins, this finishes well, and is flexible but durable.

#4 The retractable mechanism is made up of two parts of plastic that are moulded to fit together, and then both fit inside a sleeve in the second half of the casing. By depressing the top section, it moves the bottom section round, and slots into grooves inside the sleeve.

#2 The spring is part of the retractable mechanism, forcing the ink cartridge back into the casing when needed. It is made from stainless-steel which retains its stiffness over long periods of time.

Technical Specification

Form:

- The product must feature an ergonomic grip that will prevent the user from feeling discomfort from using the pen, as well as providing accurate writing.
- The shape must be long and wide so that the pen can be supported by the users hand easily, but not so wide that it affects writing accuracy.
- The case of the pen must have a see through section, so that the level of ink inside is visible. This will allow users to see when the ink level is low so that they can buy a replacement cartridge.
- To further aid ergonomics, the writing end of the pen must be curved so that the user's fingers can grip it if needed without causing discomfort.

Performance Requirements:

- The pen must be both reliable and durable. It should not be damaged by being dropped and should still work after long periods of not being used or getting wet.
- The ball point should provide accurate writing; the retractable mechanism or any of the casing should not interfere with the direction of the ball point's movement.
- The ink flow from the pen should be consistent; it should flow at the same rate even if it has been used for 2 hours continuously or not used for a week.
- The grip should cause minimal fatigue to the user's hand. It should be comfortable to hold and cause no pain during use over long or short periods of use.

User Requirements:

- The user wants a pen that is easy to use, which also has good writing quality and is durable.
- The user wants a pen that looks professional. For example; if someone was to take it to a meeting, they would not be embarrassed to use it due to its styling.
- The user needs to be able to replace the ink cartridge inside the pen so that they do not need to throw the whole pen away.

Scale of production and cost:

- The scale of production for this product will be very large; it must be able to be easily produced within a factory using current production methods and materials. Batch production is the ideal method of production as it reduces costs.
- The materials should be available in bulk so that they can be brought at cheaper prices to lower the production cost. Anything too expensive will raise the product cost and the pen will not sell well.
- The products must be easy to pack, so to save space during storage and transportation to various retailers.
- The product should be made with standard components, so that these components can be brought off suppliers.
- It should be very easy to assemble, lowering the amount of machinery required to put it together.
- The price of the product should be competitive in this particular market.

Material and component requirements:

- The materials used must be durable and able to withstand being dropped multiple times, while still functioning correctly.
- The material must have a nice clean finish to it. A glossy, clean finish will make the pen look more professional.
- The materials should be scratch resistant; if left in a pencil case with other pens, rules etc, they should not scratch the material.
- Being easy to work with is important to keep costs down. The materials must work with all current methods of large scale production.
- The components which make up the casing must be able to be taken apart easily by anyone, so that they can replace the ink cartridge. This way of joining the casing must be durable and easy to use.
- The materials must be cheap and readily available for production.

Function:

- The pen must be able to provide the greatest possible writing accuracy, while causing minimal discomfort to the user.
- The retractable ball point mechanism must be durable and easy to use, whilst not affecting the quality of writing.
- The method for replacing the ink cartridge must be simple and easy to do, whilst not changing the overall durability of the pen.
- The overall value of the pen must be high. This will be created by adding efficient features, at a low cost.
- The pen must have a clip which can be used to keep the pen at the top of a pocket or clipped onto paper.

Product Comparison

The prod. will be comparing with my gel pen is the Pilot Rexgrip. Although it is made by the same company and has fairly similar features, the quality of this pen differs from the Pilot G2. I will be comparing the quality and features of this pen with the previous pen using the technical specification.

Form:

Overall this pen shares a similar shape and features as the G2 pen. However, upon closer inspection and actual use of the pen, it is clear there are differences.

There is a rubber grip on this pen to provide some comfort. However, this rubber is considerably harder and slipperier which quickly causes pain similar to that of using a pen without a rubber grip. It also provides no benefit to accuracy of writing.

The shape of this pen and the G2 is almost identical, only the rubber grip on the G2 makes it wider. The case of this pen is see-through although the coloured plastic makes it hard to see the actual ink level, this problem is particularly noticeable with the black coloured pen. Also, once the ink level is very low, the rubber grip prevents users from seeing how much is left.

The end of the pen is curved and the rubber grip curves with it, unlike the G2 where the rubber stays straight. The curving slippery rubber could be annoying after long periods of use if the users had starts to slide down slightly.

Performance Requirements:

This pen is reliable and durable, as well as scratch resistant. This is because it is made out of the same materials as the G2 pen. The retractable mechanism works on the same principals as the other pen. However it is housed in its own plastic casing which is very difficult to remove. This provides greater durability and no bits can be lost while changing the cartridge, this is an improvement over the G2's mechanism as small bits can fall out.

The ink flow of this pen is also consistent as it uses an almost identical ball point to that of the gel pen, only this is optimised for normal ink. If left for a long time it takes a few "scribbles" to get the ink to flow, but this is typical of ink pens.

As mentioned before this pen does cause some fatigue after long use. It feels alright at first but after an hour or 2 of use the harder, less grippy rubber causes your finger tips to ache.

User Requirements:

Overall this pen has fairly similar ease of use, quality and durability as the G2 pen. It falls behind in some areas like the grip and changing the cartridge, but makes up for this in others like the extra durability of the retractable mechanism.

The overall colour theme of this pen (the colour of the ink and the white cap) stands out amongst other pens. This standing out almost makes the pen seem less professional. It doesn't have the same sleek look as the G2, it has a more fun appeal for school children.

Replacing the ink cartridge is not as easy as the other pen. The only part of the case which unscrews is the very tip of the pen. People with stubby fingers may struggle to open this if it was put on tightly before. Also the spring must be removed and put over the new cartridge, the problem with this is that the spring could be lost and then the pen would be useless.

Inserting the cartridge requires some concentration as the hole is small and the spring can get stuck on the sides. Overall it is not as easy as the G2 pen.

G2

Rexgrip



Function:

The hard rubber on this pen allow for accurate writing, but at the expense of user comfort. For use over short periods this pen is good, but over longer periods and it causes your fingertips to ache.

The retractable mechanism of the pen works in an almost identical way to the G2 pen. This has less of a "solid" feel to it, but it works the same and is durable. Replacing the cartridge is not as easy as with the G2, as you have to remove the spring and then fit it back through the small hole, then screw the top back on which can be hard if you don't have a steady hand.

The clip of this pen is a similar design to that of the G2 gel pen. It is made of the same material and so has the same flexibility and durability as the G2.

Overall the value of this pen is quite good; it has a range of features similar to that of the G2. However, the quality of some of these features is somewhat lower than the G2.: The hard grip and the difficult to remove lid are examples of where money has been saved, but quality has been dropped. Although the Rexgrip is cheaper, the prices of the cartridges are the same and so buying the G2 is more worthwhile and so has higher value.

Material and Component Requirements:

The pen satisfies all the criteria for this part of the technical specification. It is made from readily available materials that are easy to work with and can be made using current manufacturing processes. The materials also have a glossy finish that is reasonably hard to scratch. This pen is on par with the G2 as they are both made from the same material and by the same manufacturing process.

The only part that falls behind is the way of removing the cartridge from the case. The screw off section is located at the very end of the pen and this gives little room for people to grip the screw. If you have greasy or damp fingers it is almost impossible to remove.







Furthermore, the spring gets caught in the side of the case when being removed and put back in. When compared to the G2, it seems a lot harder; this is because you can use the rubber grip of the G2 to help unscrew the casing. The spring also fixed at the top so it doesn't come out when changing cartridges.







Scale of Production and Cost:

The scale of production would be almost identical to that of the G2, the only difference being the parts which are made. It would use the same machines, the same material and the same standard components as the previous pen, just different moulds. The production method would be "batch production" as a very large quantity are produced at once and then another batch will be produced at a different time depending on demand for the pen.

As the production and materials are the same, the cost of production is the same as well. The reason for the retail price of this pen being less is that things like the harder rubber grip have a lower material cost. So while it costs less, the overall value of the pen is lower.

Materials and Components: Actual and Alternative

Part	Material; Actual	Properties	Justification and Conclusion
Rubber Grip	 Grip: Pigment Resin Plastic	This is a soft material that is flexible yet hard wearing. It can be moulded and fit around many shapes.	Justification and Conclusion Being soft yet hard wearing means that it is durable and won't rub off onto the user's hands, or start to dry out/fall apart. Being flexible, it will be able to compact slightly when gripped, making it more comfortable to use.
Spring	 Spring: Stainless Steel	This material resists corrosion and is rather stiff. It is also cheap to produce/use and can be shaped in numerous ways.	The stiffness of the material insures that the retractable mechanism will always return to the correct position after many uses. Resistance to corrosion will prevent it from weakening due to rust, and will also keep the pen looking clean.
Ink Cartridge and Roller Ball	 Ball point: Tungsten Carbide Ball casing: Brass Ink Cartridge: ABS	Tungsten carbide is a very durable material; it can take a high amount of stress/pressure without deforming or cracking. The brass surrounding it is wear resistant but cheaper than the tungsten. The ink is stored in the ABS tube which is easy to shape and is lightweight, as well as slightly flexible.	The highly durable parts make for a long lasting and consistent ball point. This means that the user will experience no change to the feel of writing. The ABS is see through and allows the user to see how much ink is left; this is very convenient and is a good feature. It is also flexible, meaning that the ink cartridge won't break if bent which could cause lots of frustration for users.
Pen Casing	 Pen Casing: Polystyrene	This is a stiff and scratch resistant material. It is easy to work with and provides a nice see through finish once formed.	The see through finish allows the user to see how much ink is left. The surface being scratch resistant also keeps the pen looking nicer for longer. Being easy to work with is important as it needs to be manufactured using current/cheap techniques.
Retractable Mechanism	 Retractable Mechanism: Polypropylene	This material finishes well and is also flexible. It provides a nice opaque finish and can be coloured using different dyes.	This material does not wear always when coming in contact with other materials. This makes it perfect for this use as the parts are constantly rubbing together and need to retain their shape.
Casing Cover/Pocket Clip	 Casing Cover: Polypropylene	This material finishes well and is also flexible. It provides a nice opaque finish and can be coloured using different dyes.	The opaque finish is good for covering up the retractable mechanism within the case. The shiny finish gives the pen a better overall look. The flexibility means that the clip can be bent without permanently deforming it. Being able to colour it means that different colour inks can be shown by the colour of the casing cover.

Part	Material; Alternative	Properties	Justification and Conclusion
Rubber Grip	 Grip: Rubber	Is soft and easy to work with, readily available. Provides a grippy surface.	Justification and Conclusion The grippy surface would provide great accuracy for users. However, it would easily collect dust and can wear away easily. Being widely available means it would be cheap to buy and it can be shaped using current manufacturing techniques.
Spring	 Spring: Aluminium	This is a strong material that is both stiff and corrosion resistant. It is also lightweight and readily available.	This material would resist corrosion and stay stiff, however it does not have good flexibility and could be permanently deformed if bent too much.
Ink Cartridge and Roller Ball	 Ball point: Titanium Ball casing: Titanium Ink Cartridge: Polystyrene	Titanium is very strong and can resist deformation under large pressures. It is scratch resistant and corrosion resistant. The polystyrene is strong and easy to work with.	The titanium is very durable and would easily outlast the life of the ink many times over. However titanium is not as common as most metals, is hard to work with and has a very high melting temperature. The polystyrene is not flexible and so a crack in the ink cartridge would result in ink leaking.
Pen Casing	 Pen Casing: ABS	ABS is easy to work with, strong, light weight and can be dyed in many different colours, or left clear.	This would be a good material to use as it is light weight and strong, is cheap to use and does not scratch easily. The clear casing can show users how much ink is left. It is also less brittle and so wouldn't shatter easily.
Retractable mechanism	 Retractable Mechanism: Acrylic	Acrylic comes in a large variety of colours, it is flexible yet brittle. It is easy to shape and works with all plastic manufacturing processes.	The acrylic would wear down soon and would begin to look scratched after use. If it wears down too much the mechanism does not work and so the pen is useless.
Casing Cover/Pocket Clip	 Casing Cover: Acrylic	Acrylic comes in a large variety of colours, it is flexible yet brittle. It is easy to shape and works with all plastic manufacturing processes.	The brittle material may be dangerous as if the clip is bent to far back, it could snap leaving sharp edges, and also it scratches easily and would soon look old. If it snaps it could also be a safety hazard, as it is known that many people chew the ends of pens.

Materials and Components: Summary and Environmental effects

Summary:

Grip:

The actual material is a lot better suited to the task as it is hard wearing. The rubber is likely to go hard over a period of time, were as the resin well retain its softness. Both materials are easy to work with and both are fairly cheap to buy.

Spring:

Both of these materials would suit the situation well. However, stainless steel retains its shape better and so is more durable and would be consistent, keeping the retractable mechanism working properly.
Ink Cartridge and Roller Ball: The ink cartridge being made of ABS has a number of advantages over the polystyrene one. Thin ABS is flexible and so if the cartridge is bent slightly it will not be permanently damaged. Polystyrene is brittle and if bent slightly would crack and possibly shatter; this would be a very big problem as ink would leak everywhere and possibly cause damage to the users belongings.

The ball point could be made from either tungsten carbide or titanium. Both have the properties required to provide consistent ink flow over long periods of use, and are both very durable and scratch resistant. Titanium is very hard to work with, and is a more limited resource than tungsten. Because of this, titanium would be a lot more expensive to use and would raise the overall price of the pen. The ball casing can be either made of brass or titanium. The problem again is the price of titanium, it would be too expensive to use and would out last the amount of ink many times over, making it unnecessary.

Pen Casing:

Using either ABS or Polystyrene as a pen casing would not make much difference. They both share similar properties, that they are strong and can be coloured etc. The one difference is that the polystyrene is a lot more brittle, it can shatter where as ABS will just deform permanently, but not form any sharp pieces.

Retractable Mechanism:

The polypropylene has a few advantages over the possible acrylic replacement. Firstly, polypropylene retains its smooth surface for longer than the acrylic. This stops the pen from quickly look worn down or shabby. Secondly, the acrylic will start to scratch and wear away after long use. This will affect the performance of the mechanism over time and it will be noticeably different or even not work after a long period of time. Thirdly, polypropylene is not brittle and will not shatter, this will prevent any sharp pieces breaking off as a result of large pressure being applied. Acrylic does shatter and so is not so good for this purpose.

Casing Cover/Pocket Clip:

For similar reasons as the mechanism, the casing cover is best made out of polypropylene. The main reason for this is because acrylic can shatter. People tend to chew the ends of pens and if the end shattered then it could cause serious harm to users. It also finishes nicer and so makes the pen look better.



Environmental effects:

Extraction and processing of raw materials:

All the materials used, beside the ball point and its case, are some form of plastic. Plastics are made by mixing different compounds together at different pressures. The elements that make up these compounds first have to be extracted. Majority of these compounds come from oil, which is a resource that is slowly being depleted. Also, the reaction of these compounds produces gases which can be both toxic and harmful to the environment. The extraction of the metal for the ball requires digging up the metal from the earth, which is using a valuable resource.

Production Processes:

The process of making these parts requires electricity. It is needed to heat the plastic first, then heat the plastic, move it around, etc. All heaters and motors need electricity. Power plants mainly still use fossil fuel and as a result this electricity usage produces greenhouse gases. Any leftover/cut off pieces of plastic are recycled. This reduces the strain on the environment and saves the company money as well. The creation of the metal balls for the ball points also requires a lot of electricity, in order to metal the metal; huge amounts of electricity are required. Also, sanding it takes a long time which consumes many hours of electricity.
Disposal of Products after lifespan:

Disposal:

This product is designed so that only the cartridge inside needs to be replaced. This keeps the amount of product discarded to a minimum, which is good for the environment and also saves the user money. The problem is that many people simply throw the pen away, and as this is made of mostly plastic, it will never degrade. These pens will fill up landfill sites and stay there for a long time. The last part of the product to survive would be the roller ball. This is likely to last over 50 years due to its strength. They aren't recycled as their shape cannot be changed without a powerful source of heat.

Manufacture

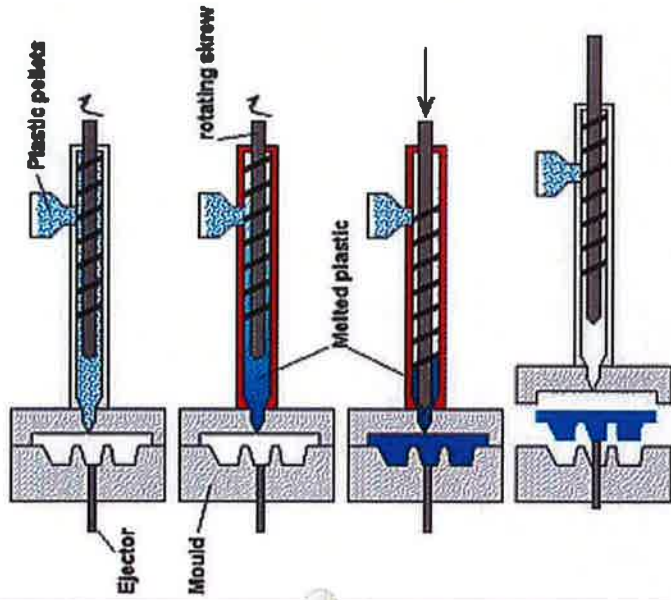

Injection Moulding

The pictures above give a very basic look into injection moulding. You can see the granulated plastic pellets in the hopper as shown in the top picture. These are then forced along by the rotating screw, which is also heated, making the plastic runnier.

This is then pushed into the mould. The mould in this case would be made from 2/3 pieces, in order to make the hole in the middle. The molten plastic fills up all the corners of the mould. The mould is then cooled by water so that the plastic hardens quickly. Ejector pins push the plastic object out without damaging it. This makes the process fast and removes any human error.

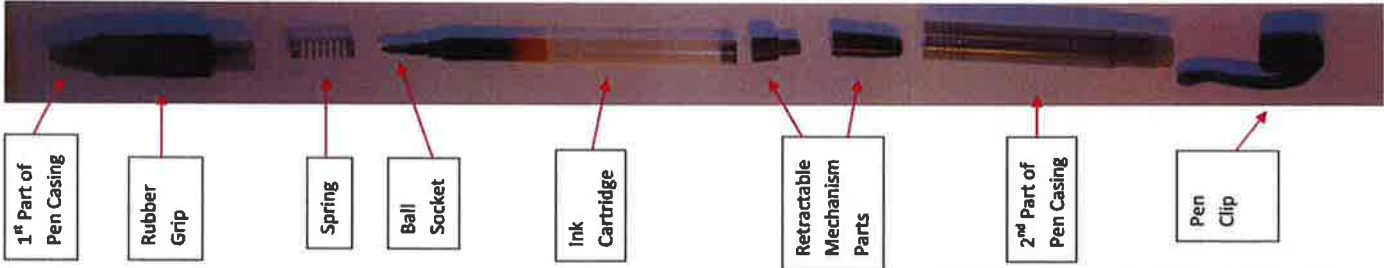

Part	Process	Description of the Process	Justification: Advantages and Disadvantages
1 st and 2 nd Part of Pen Casing	Injection Moulding	The casing starts off as granules of plastic. These are heated up and then forced into a mould by a screw. The mould consists of a male and female piece. On the 1 st part of casing the mould will have a thread on the female piece, while on the second it will be on the male part. The female piece is made of 2 halves that come together, so that the casing can come out easily. The mould is cooled quickly and the casing is ejected by pins and closed for the next piece.	The pieces can be produced very quickly this way. Also the thread can be done in a lot more detail, as well as adding detail to the inside of the casing, which couldn't be done in blow moulding.
Rubber Grip	Injection Moulding	This is also made using a female mould consisting of 2 parts, and a male section which keeps the hole through the middle. Hot rubber is pumped into the mould and cooled quickly, then removed using pins to push it out.	The pieces can be produced quickly and the small ridges in the grip can be produced accurately. This detail could not easily be achieved through other processes.
Spring	Coiling and Hardening	Wire is wound around a shaft called an arbor or mandrel. This shaft is attached to a lathe with the mandrel secured in the chuck. A guiding mechanism is then used to insure the wire has the correct "pitch" as it wraps around the mandrel. Once the desired size is reached, the metal is cut and the process starts again on a new mandrel. To relieve the stress within the coil, the coil is tempered by heat treatment and is allowed to cool slowly.	This process is efficient and fast, allowing accurate size springs to be made without wasting much metal.
Ball Socket	Stamping and Forming	Sheets of brass are stamped into small pieces and then softened. They are placed into a compression chamber and then forced into a die cast mould. The brass takes the shape of this mould and is then ejected.	Like injection moulding, this process is quick and efficient, allowing lots of pieces to be made in a short period of time. The moulds are accurate and have little disadvantages.
Ink Cartridge	Extrusion	Plastic granules are heated and then pushed through a jig with a screw, the plastic that comes out makes a long extrusion of the jig shape. This is then cut at set intervals. These short pieces are the ink cartridges.	This is a continuous process which allows for fast and consistent production. It wastes no material as all the material coming out of the jig is used. It also allows for changing the length of the tubes without having to make a new mould.
Retractable Mechanism Parts	Injection Moulding	These small parts are made using a 2 piece mould. Both of the parts of the mechanism may be made using the same mould to save time.	This is a very fast and effective way to produce small parts. Many pieces can be made within one mould at once. It's also a process which allows for small details to be made accurately.
Pen Clip	Injection Moulding	This part would be made from a more complex mould, due to the shape of the clip and the hole in the middle to fit the pen cartridge inside. Most likely it would be a three piece mould.	It is a quick process which would allow lots of parts to be made in a certain time period.
Whole Pen	Assembly	The different parts of the pen are made all at once and come together via conveyers. First the ink cartridge is connected to the ball socket and is then filled with ink. This is then placed inside the second part of the casing along with the retractable parts. In the first part, the spring is placed in and the rubber grip is pushed over. These parts are then brought together and tightened.	This ensures that the product is assembled quickly and accurately, as it removes any human error that would occur with hand assembly.

Environmental Effects

Environmental Effects of Injection Moulding

The environmental effects of injection moulding are quite serious. The process itself only uses electricity, as with almost every other process in a factory. This is polluting to the environment, unless the electricity is taken from renewable sources.

The main environmental effects come with the various plastics used in this process. They all mainly come from non-renewable sources such as oil. This uses up the earth's resources and has an overall negative effect.

After the product is used, it is thrown away. The large majority of injection moulded plastics do not degrade, and so are left in landfill sites for a very long time. Some of the plastics can be recycled, but only those that are thermoplastics. Furthermore, any plastic that is ingested by wildlife can have toxic effects on them. Many plastics contain very toxic additives, which can leach out when in contact with certain foods or acids (like stomach acid).

Also, burning these plastics from injection moulding can release toxic gases. The plastics decompose when heated and release toxic by-products which pollute water.

Environmental Effects of Extrusion

The main effect on the environment from this process is the electricity used to heat up the plastic and also push it with the screw. This would not be so bad if the energy came from renewable energy sources, but at this point in time its likely they do not.

Like with any plastic process, it involves taking the plastic from non-renewable resources. This cannot be replaced, and some of the plastics cannot be recycled. This adds to the countries land fill, as things like pens are often thrown in the trash without thinking twice.

If these plastics are overheated or burnt, they can release toxic gases which can then pollute water and clouds (acid rain).

Environmental Effects of Spring Coiling and Hardening

Besides the electricity used up, this process uses another non-renewable resource, iron. The iron is mixed with carbon to make the steel. The process of making steel produces CO2 which is known as a green house gas. Luckily, steel can be melted down and reused. However, lots of it isn't recycled, and it sits in landfills for many years taking up space. It can also rust, which can be a hazard.

Alternative Process

Comparing a Process: Rubber Grip – Heat Shrink Tubing

Instead of the injection moulding the rubber grip normally uses to take its shape, there is a different process that can be used to ease the way it is moulded and the way the pen is assembled as a whole.

The method involves heat shrink tubing. Firstly a plastic is used called polyolefin; this is a thermo plastic and has similar look and feel as wire insulation. Instead of injection moulding, the plastic is extruded as a long hollow circular shape and then cut at certain points so that it is slightly larger than the desired pen grip length. This tubing is then placed over the area of the casing designated for the grip. Heat from a hot air gun or heating element is placed evenly around the tubing, which then shrinks and tightly grips the pen. This is caused by a reaction with the plastic's molecular structure and heat, which causes it to permanently shrink.

The feasibility of this method is similar to that of injection moulding. The same amount of electricity is used, as it doesn't involve pumping plastic into moulds, but does involve heating the plastic a second time to get it to shrink. Also, this method uses more material to get the same sized grip. Because the plastic shrinks, a larger thickness will have to be used to start off with.

Advantages and disadvantages

This process makes the assembly easier as the two processes are combined. Also, the extrusion is continuous so parts are produced continuously. The disadvantages are that no ribs/markings can be left onto the rubber. Also, the process uses up more electricity because of the heat needed to shrink the rubber.



An example of before and after heat shrinking.

Quality Control and Assurance

Quality Assurance Systems:

This is a planned and systematic process within the production processes that provide confidence in a product's suitability for its intended purpose. In the case of pens, it will give the user confidence that the pen will last till the ink runs out, and that during that time it will be of consistent quality. It is a set of activities intended to ensure that the pen satisfies customer requirements in a systematic, reliable fashion. QA cannot absolutely guarantee the production of quality products, unfortunately, but makes this more likely.

Part Tested	Quality Control Procedures	Quality Assurance
Roller Ball/Writing Consistency	This part of the pen is tested once the roller ball and its casing are joined to the ink cartridge and ink is inserted into the ink cartridge. The cartridge is gripped by a machine that then runs the ball over a piece of paper. Below the paper is a sensor that is able to monitor any abnormalities in the movement over the paper. A camera records the ink left by the ball, it is then able to determine if the ink is flowing properly, when compared to a different recording. To test this, random samples are taken from each batch. If one sample is faulty, more are tested. If these also turn out to be faulty, the batch is discarded. This is to check the writing and ink consistency of the ball and the ink.	This test is chosen as it was can affect many users' choices in what pen to buy. The writing quality must be maintained at a high level so that customers can be assured they are buying a "precision writing instrument", not just a cheap pen that lacks quality.
Grip Integrity	Once the Grip has been applied to the lower part of the casing, the grip is then tested to insure it is in place and has the correct shape. This part is tested visually. Trained inspectors take random samples, then hold the grip to get a feel of it, using their knowledge of what the grip should be like, they can then compare to the sample they are testing. They look at the ribs in the grip, as well as the overall smoothness of the surface, for any lumps or deformations. This test is done to make sure all the grips are smooth and function well, as a deformed one will irritate the user.	This is also another important part. If users are paying for a pen with premium features, they want to see that their money is well spent. The testing of the grip will assure users that it will be comfortable to use and not wear away over time.
Retractable Mechanism	This part of the pen is also tested by inspectors. It is done once the whole pen is assembled. Samples are taken out of a batch and are tested by simply extending and retracting the roller ball a few times. Once the inspectors have done this and they feel that it is up to standard, they place the pen back. If it is not up to standard, they check why this is, either from deformed parts or missing springs. They check this with other samples and if the problem persists, the batch is discarded and recycled. If this part of the pen does not work the pen is redundant, so it is very important that it is working well.	The retractable mechanism must work in order for the pen to work properly. If not, the pen will not function and users will be put off from buying the product again. It is important that users know the pen works well in every way, and that this part has not been neglected.
Case Thread	This stage tests that the 2 parts of the case can be screwed and unscrewed. It is done before the ink cartridge is inserted. A machine does this stage. It simply takes the two parts of the pen and screws them together. If any problems arise the pen is discarded. This check is done to all pens as it is incorporated into the manufacturing process, without slowing down the rate of production. If these parts don't fit together then the pen will not be assembled properly at later stages.	This is not such an important check, as it is known that many users throw their pen away when it is run out, instead of changing the ink cartridges. This check ensures that the pen will fit together properly, as users generally won't notice if the thread is a little out of place. However, some users do change cartridges, and they have to be assured that they can easily undo the pen if they need to.
Whole Pen	A final visual inspection of the pen fully assembled is performed again on random samples of a batch of pens. Things like colour co-orientated grips and inks are checked, any pens with deformations are removed, and any scratched pens are discarded and the source of these scratches is found. It is easier to do this with inspectors as they can detect errors instantly that computers may not recognise. This final check gives the user assurance that the pen is in complete working order.	The whole pen is checked as a final way to ensure that users can get complete quality assurance from the pen manufacture. This eliminates any potential problems that may occur. The user can confidently buy this product.

Quality Standards:

This company's product complies with standards related to the products it sells. The standards it complies to are: ISO 12756, ISO 12757 and ISO 14145. These are all general writing utensil standards. In order to obtain these, the company must fulfil certain criteria during production and product tests. After these, the accrediting body can award the standards. These allow other companies to know that its products are well designed, safe to use and work consistently. The user does not get to see these standards, as it is unlikely they know what they mean, but it is important for people like suppliers and distributors so that they know money isn't being wasted. It will also comply with smaller standards that are only relevant to certain countries, but these are generally similar to ISO standards.

The products are inspected by an accrediting body that compare the product to a list of specifications. If the product meets these specifications, it will be given a certificate saying it has met them.

Design and Manufacture of the Product:

In order to get the quality standards, companies must both produce and design their products in a certain way. They must be safely produced, using processes that don't pose any major harm to the environment. The materials used must be non-toxic, as any threats to health immediately prevent it from getting these standards. Other specifications it has to meet are related to durability and overall ease of use. The original design has most likely been changed in order to meet these requirements.

GCE in Design Technology
(AS) Product Design – Resistant Materials Technology
Unit 1 – Portfolio of Creative Skills (6RM01)
Product Design

For Production:
The Base will be cut on a CNC router, while the clamp can be cast from aluminium, and the head can be blow moulded. However, all these parts will need to be assembled together by hand, as there are complex parts. It would be costly to mass produce.



The head of the lamp will be blow moulded, and then have a section cut out to allow light through.

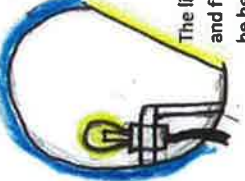

This design features lots of thin wires that all group together to support the head of the lamp.

The light bulb and fitting will be held in place by a small stand.

This is the clamp that would be attached to the back of the head; it will be cast from aluminium. Screws tighten the clamp, keeping all the wires in place and supporting it.

The ends of the wires will need to be threaded; this will secure them to the base of the lamp. The base will have countersunk holes where nuts can be used to secure them into place.

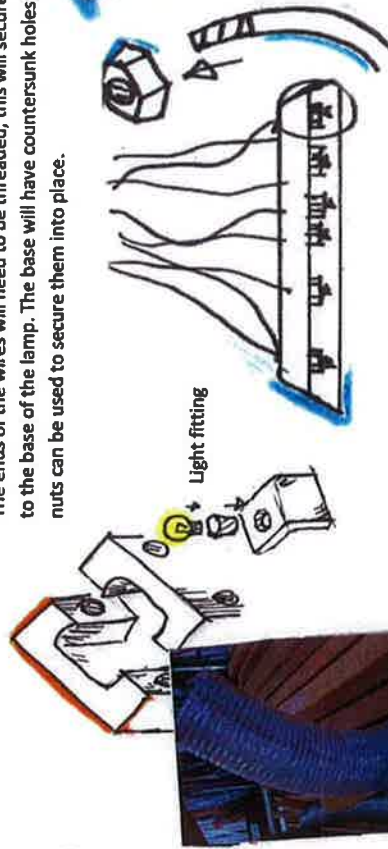

Light fitting

One problem with the above lamp is that it will be very hard to adjust. It could only be angled by bending all the wires, but this would weaken the lamp over time and be frustrating for the user.

Goose neck is used to allow the lights to be bent in the desired direction. These give the lamp a strange alien like look that some may find aesthetically pleasing. The number of lights provides lots of adjustability.

The light bulbs used would have to be compact, but be 240V in order to fulfill the specification.

For Production:

This lamp would be hard to produce as there are many parts that need to be assembled by hand. This would lead to a rise in production costs. The base would be made on a CNC router, cut from acrylic.

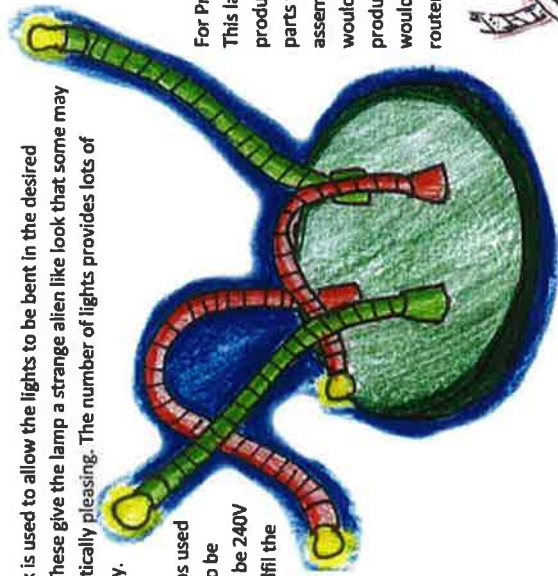

The goose necks will be held in place by nuts. These will need to be countersunk into the plastic in order to keep the base stable.

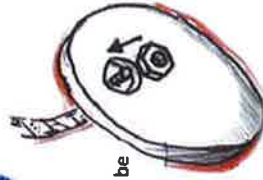

The wires will be stored within the goose neck. The nuts also need to be countersunk to make room for wires. Rubber feet could be used to raise the base and provide more room.

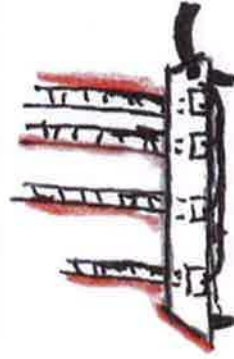

A way of housing the light fitting is to have a support from the frame which holds the fitting in place. The concave reflector can also be held in place by this support.



For production:

The Tubing can be extrusion moulded, and the internal frame can be cast. The concave will be injection moulded. All these processes are suitable for mass production.



An internal frame will be needed in order to keep the tubing in the desired position. It will do this by having rubber washers in between each join in the frame, providing stiffness.



The base will be a block of wood, to add weight.

This design came from plastic tubing. The tubing forms the outside of the design. This could easily be extrusion moulded.

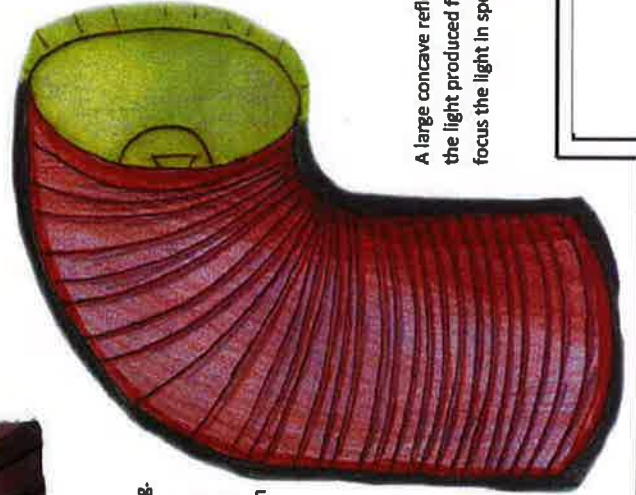

A large concave reflector will be used in order to reflect all the light produced from the bulb. This will allow the user to focus the light in specific areas.

Could be used as a ceiling light as well.

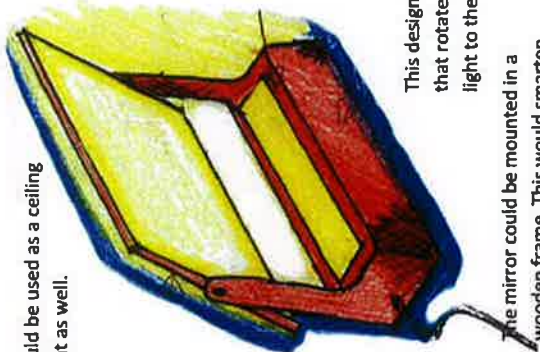

This design features a mirror that rotates in order to direct light to the desired area.

The mirror could be mounted in a wooden frame. This would smarten up the design, and also prevent the mirror chipping.

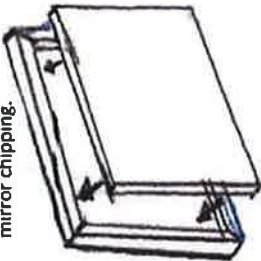

The mirror could be made from aluminium, and then polished. Would be safer.

For production:

The main section of the lamp would be assembled from wooden planks, with square sections of wood at either end. The mirror would have to be imported from a supplier.



In order for the mirror to rotate, it would have to use rotating hinges that grasp the mirror from both sides, almost like a clamp.

For Production:

As mentioned, the 4 plastic pieces can be formed from a single mould, then have a section cut out of them for the lighting. However, assembling the whole product will take a lot of time and will most likely have to be done by hand.



The plastic (acrylic) can be moulded into shape by heating it up and placing over a former, then leaving to cool.

This lamp is made from 4 separate pieces of twisted plastic. In the middle there is a ledge for a light bulb and fitting, so that light can be shone out at all directions.

Although light is shone out in all directions, there is no adjustability. It is in a set position and so cannot be focused on specific areas.



The idea of putting photos where the light comes out in order to light them up seemed like a great idea. Although this would significantly limit the amount of light that would get through, making it less of a lamp and more of a display piece.

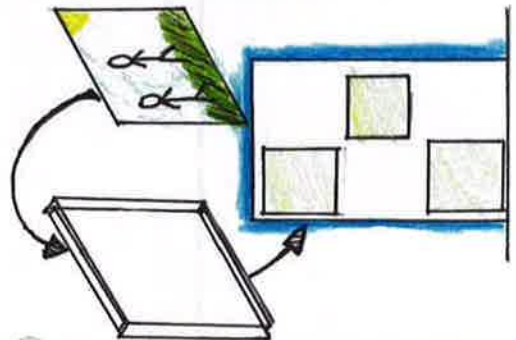

The design below is based on a tower block. It would be about 25cm tall and have 2 light bulbs inside it.



For Production:

There are two ways in which this lamp could be made. One is by vacuum forming one side, then gluing or screwing it to a flat piece of plastic. Or two pieces are injection moulded and then screwed together.

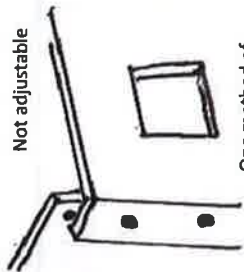

Not adjustable

One method of joining is by

As there is lots of spare space below the light this could be used to make things like holes for pencils and pens. It could be re-designed as a desk tidy and lamp in one.

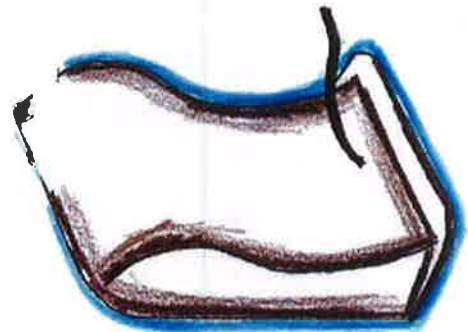

From the back this design looks ugly. A way to clean it up is to add some curves and a slight angle inwards. It is important to maintain a wider base area to ensure it doesn't fall backwards.

Width: 80mm

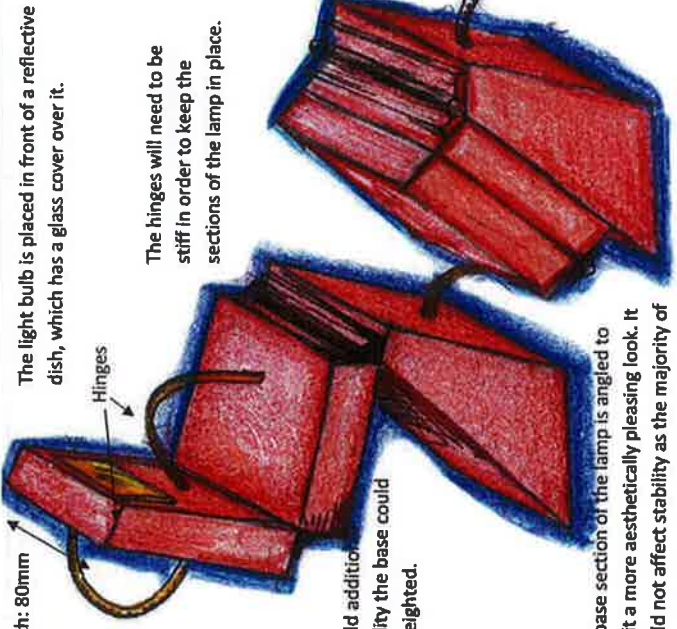

The light bulb is placed in front of a reflective dish, which has a glass cover over it.

The hinges will need to be stiff in order to keep the sections of the lamp in place.

To add additional stability the base could be weighted.

The base section of the lamp is angled to give it a more aesthetically pleasing look. It should not affect stability as the majority of the weight is over the base

The lamp is designed to fold away. This makes it easy to store after being manufactured and for the user when it is not in use.

The wires for this lamp will have to be stored outside of the lamp body. This is to allow easy movement between the two parts.

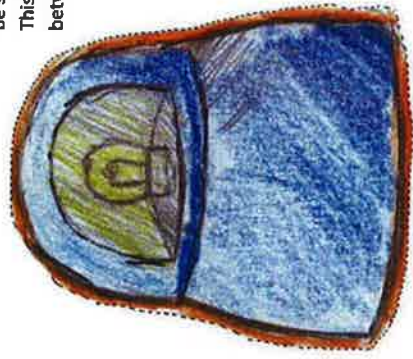

Front view: Light is contained within an enclosure that has a reflector at the back and a glass cover on the front.

For Production: These parts would be injection moulded, as this is a suitable mass production method which will make it easy to create the angles for the base piece and to create the section for the lighting.

The wire could not be contained within the lamp as it would become trapped when folded up.

Hinges allow light to be adjusted to different heights/angles



Knuckle joint
The hinge fits like a socket, then bolted in place.



For Production: The aluminium square tubes can easily be extruded. The inclusion of a hinge will make the lamp more adjustable and easy to store.

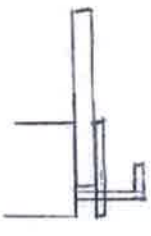

The lamp will use a fluorescent light bulb; this means that light can be produced from the length of the lamp.

A clamp will be used in order to keep it stable. The lamp will have to be attached near the edge of a desk.

Aluminium could be polished for a nicer finish.

A hinge would allow the lamp to be stored upright. This would also save space for transportation.

This is suitable for production as it is made up of two aluminium square tubes that are welded together.

This is a design which lights up the desk space below very well, without taking up too much desk space itself.

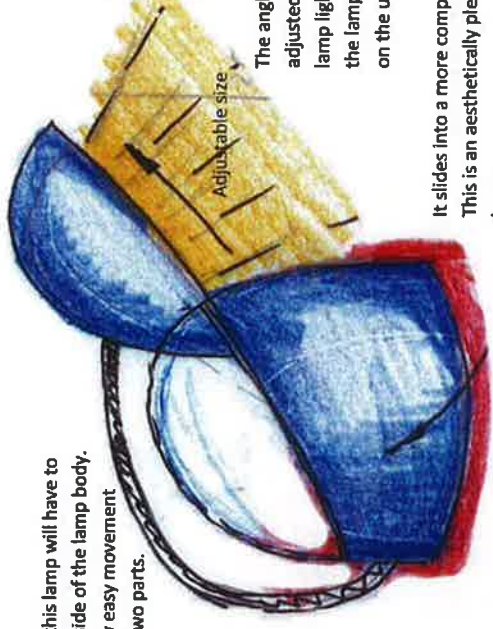
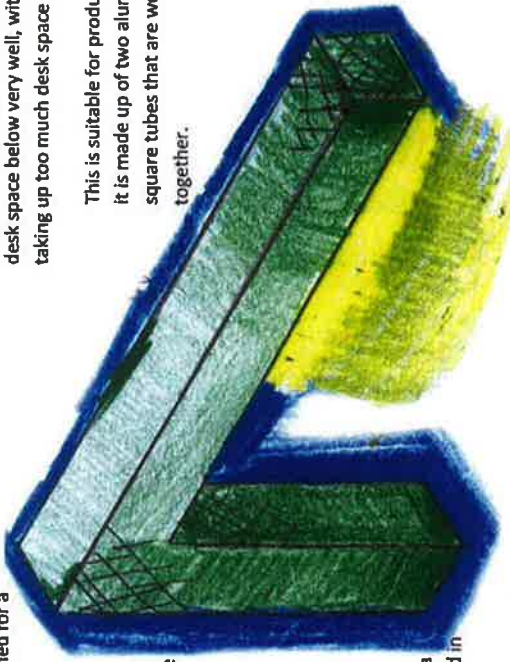

The angle of the lamp can be adjusted so that the area that the lamp lights up or the brightness of the lamp can be changed depending on the user's needs.

It slides into a more compact shape. This is an aesthetically pleasing lamp.

A rubber stopper will be attached to the top piece which then fits into a groove on the bottom piece. The fit must be tight in order to insure a stiff mechanism that can hold the top piece in place.



If the sliding mechanism was stiff, the base would need to be either weighted or have rubberised pads. This is to stop the base sliding when the user tries to push it up.

For Production: These will also be vacuum formed, although the rubber stopper will have to be brought from suppliers. This wouldn't be so easy to mass produce as the assembly of the sliding mechanism will take some time and will most likely be done by hand.

	<p>I feel this design is aesthetically pleasing. The way it is designed gives it a unique look, with the angles and the way it folds up. However, the wire needs to be hidden or only shown in short lengths to keep it looking smart.</p> <p>Modern 7/10</p>	<p>This design has a smooth, curvy finish that looks simple yet attractive. It has no sharp angles on it which many people will find desirable. In a way this design is an exact contrast to the first design. It also looks stable, given the wide base that it has, and a low height.</p> <p>7/10</p>	<p>This design has a simplistic look, which is clever as underneath it is complicated. It looks smart, yet basic. It would fit into most environments well, particularly abstract or children's rooms. It looks stable; however this can change as the shape can be changed. It looks well planted most the time.</p> <p>7/10</p>
	<p>The design will be weighted at the bottom in order to give it more stability. It shouldn't have any problems with stability unless it is fully extended vertically, which will raise the centre of gravity and make it likely to fall over if knocked due to the shape of the base. Overall it shouldn't have any serious problems with stability. The wires will be mostly inside the body of the design, so these pose little threat. However if the wires are constantly bent, they may become weak.</p> <p>Complicated 4/10</p>	<p>This lamp has a wide base that will prevent it from falling over; even when the top part is extended it is still stable. This of the low centre of gravity, as the bottom will most likely be weighted. The wires will be inside the main part of the body, but will be outside near the moving part of the design. This could be weakened over time due to the movement.</p> <p>8/10</p>	<p>The bottom of this is weighted and the internal frame is attached to this weight, so there is little chance of this falling over. Although, if knocked it would fall over as the base isn't that wide. All the electrics for this design are stored within the product so there is little to no chance of an electric shock.</p> <p>7/10</p>
	<p>This lamp is fairly simple to adjust. The light can be directed at a variety of angles, however only within the direction the base is facing. This is because the hinges only allow for movement up or down. If this product is used by young children, there is the chance of their fingers getting caught in the gaps when extending the product fully, however this is unlikely.</p> <p>Difficult, complex 4/10</p>	<p>This lamp is both easy to operate and has a wide range of movement. The plastic body contains all the moving parts so there is no chance of someone hurting themselves. The movement of this part is only along one line, due to the structure inside. Rotating the design is easy as the base is round and will not affect any surrounding objects.</p> <p>8/10</p>	<p>This design has an aluminium internal structure and a wooden weight at the bottom. The outside is made out of thin PVC which is flexible but will not wear away with use.</p> <p>7/10</p>
	<p>The parts of this product would be made out of a plastic such as ABS or HIPS. This would make it easy to work with. The hinges would most likely be aluminium, so that they don't wear down easily.</p> <p>8/10</p>	<p>The aluminium frame of this can be cast and easily assembled either by hand or by machine. The body is produced by extrusion. Both these methods are cheap and readily available to do.</p> <p>7/10</p>	<p>This lamp is easy to produce in large volumes. All the parts can be injection moulded. Then holes need to be drilled for the wire and hinges to fit into. The wire is threaded through and the hinges are screwed in. The processes used are common and so will not cost much.</p> <p>7/10</p>
<p>Aesthetically Pleasing:</p> <ul style="list-style-type: none"> In keeping with a variety of environments Proportional 	<p>Safe to use:</p> <ul style="list-style-type: none"> Will not topple Is not an electric hazard 	<p>Adjustable and easy to operate:</p> <ul style="list-style-type: none"> By all ages Directs light to different areas, producing different uses 	<p>Manufactured from suitable resistant materials</p>
<p>Suitable for volume production:</p> <ul style="list-style-type: none"> Can be made cheaply and easily in large numbers 	<p>30/50</p>	<p>37/50</p>	<p>8/10</p>

Frame Development

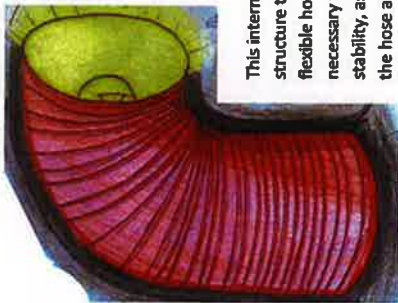

This internal frame adds structure to the reinforced flexible hose. It is necessary to provide stability, as well as give the hose a desired shape.

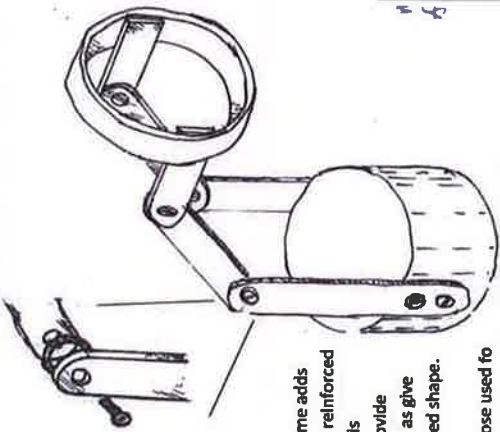

This hose used to be reinforced with plastic ribs. This means it will be harder to adjust, the webbing in between also limits movement. Replacing these with a more stretchy material will help.



Instead of using the reinforced tubing, which provides a stiff outer shell, I thought about using strips of material which allow lots of flex.

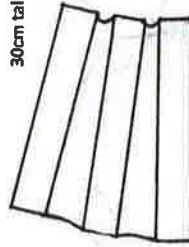

The material in between must be flexible and stretchy. Something like neoprene or latex could be used.

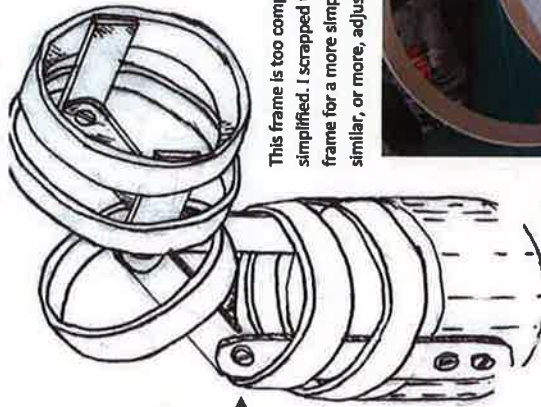

This frame is too complex, it needs to be simplified. I scrapped the strong metal frame for a more simple idea that gives similar, or more, adjustability.



This design makes the lamp more flexible, removing the stiff plastic shell. This means it would fulfill the specification better. But it is very complex. This would be an issue when produced by mass or batch production. It requires a lot of automate, meaning it would be done by hand which is not cost effective.



This is a more reinforced model of the simple frame. This solves problems with being too flimsy.

This design also allows material to be wrapped around it. Improvements over the previous design are that it is a lot firmer and easier to manufacture, using rivets and strips of plastic instead of a hard-to-make wire frame. It has a more flush profile, as the rivets don't extend far outside the frame. This would also provide good support for a light fitting and light bulb.

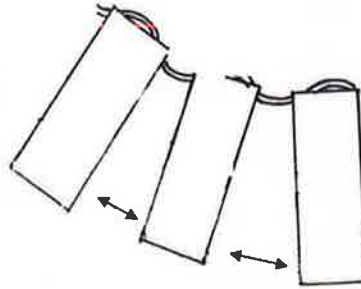

By threading metal wire through the plastic rings, it gives them a way of being joined that is flexible. It also allows material to be wrapped around, similar to the previous design. Also, it is lightweight and uses little materials.

However, this design's main flaw is that it isn't adjustable in any way. It can be rotated by hand, but that is the extent of its movement. This means it fails to meet an important part of the specification.

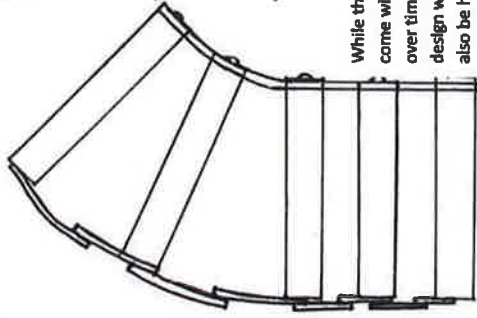

This is a re-designed version of the plastic strips. While one side stays the same, permanently joined by rivets, the other uses a scissor style attachment in order to adjust the extension on that side.

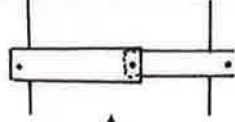
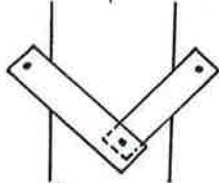

While this is an improvement over the previous designs, it does come with new flaws. The permanent plastic will become worn over time and may break if bent too much. Also the "scissor" design will become weak over time as plastic rubs together. It will also be hard to give it a sleek profile with moving parts on the outside of the frame.

Alternative Shapes

This design is a variation of the design with a wire for support. Because of the square faces of this design, it will allow hinges to be used. This will provide rigidity and flexibility at the same time.



However, this design turned out to be unstable and too flimsy, even without supporting a light bulb and fitting. It wasn't possible to try thicker wire as this was hard to attach, making manufacture hard.

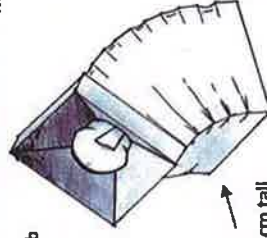

25cm tall

This design has similar problems as the square idea. Its sharp corners will tear through any material over time which will annoy many users, causing them to return the product. The only way to solve this problem is to round the edges, but that brings me back to using circles. Therefore, it is better to stick with the circular design.

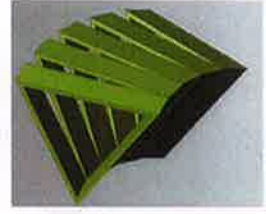

The problems with this are that the sharp corners will damage any material placed over it. Also, the hinges will add weight to one side. This weight with the light bulb will make it unstable. The shape of the design is drifting away from the circular theme which the design started off with. While this design is aesthetically pleasing, more so with a material wrapped around it, it is not the route I want to follow as it presents too many new problems which would be hard to address.

Further Frame Development



Currently, the disks are held on with glue. A more permanent solution will need to be found for production.

I decided to develop this idea into something that looked more modern. I started by getting rid of the idea of having a material cover. Having just disks will make it look more interesting. Then, by swapping these MDF disks for clear acrylic, it gives it a very futuristic look.

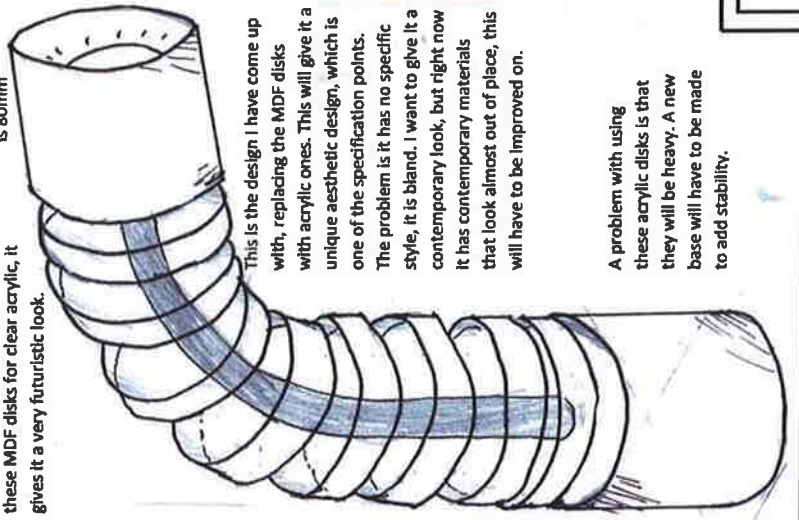

This is the design I have come up with, replacing the MDF disks with acrylic ones. This will give it a unique aesthetic design, which is one of the specification points. The problem is it has no specific style, it is bland. I want to give it a contemporary look, but right now it has contemporary materials that look almost out of place, this will have to be improved on.

A problem with using these acrylic disks is that they will be heavy. A new base will have to be made to add stability.

After looking over previous designs, I felt it was necessary to change my approach to the frame. Something simpler and straight forward is needed, which provides good flexibility without being complicated. This design features a new type of frame. It makes the frame very flexible as well as stiff, allowing a large amount of movement. It features a gooseneck that runs through the middle of MDF disks. The material, neoprene or latex, can be wrapped around this similar to the previous designs. The gooseneck is re-enforced by metal wire that runs down the middle. It can also contain the power wires, which makes it look tidier.

The material has to be stretchy / bendy to allow movement.

Manufacture of this product would be fast and cheap as the parts of the lamp can slide down the gooseneck.

Disks that surround base and head
Disks that surround the gooseneck.
Attaching these clear acrylic disks will need a cleaner and more reliable method than glue. I experimented with different methods of attaching them without glue.

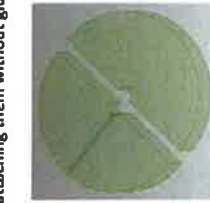

The diameter of these disks is 80mm

I'll use the above idea because the single screw is tidier and does not require the disk to be cut in half. The advantages over glue are that it does not look dirty and is not permanently fixed.



When making this I discovered that the majority of the hole had to be wider than the screw thread in order to allow the screw to fit. Without this it would make inserting the screw very hard. Also, when manufacturing this, screws of exact length would be used in order to keep the design neat. Furthermore, the screw could be countersunk to keep the design flush.

Manufacture

One way of making manufacture easy is from the use of CAM. This method is ideal for batch production, which is the most likely means of production for this lamp.

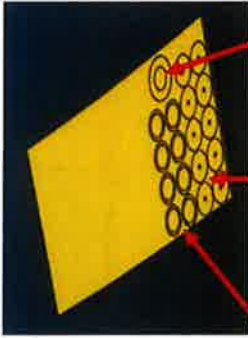

Disk that acts as the base.

Disks that surround the gooseneck.

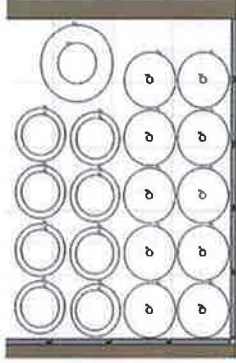

An even better method for cost saving is to remove the need to drill a hole for the pin. That part of the process can be incorporated into the cut out of pieces. A part is removed, then the two thin disks are glued together, this gives room for a pin to be inserted

The main parts of the product that will benefit from CAM are the acrylic disks. They are all similar in shape and must be cut accurately in order to fit together. The template on the left shows enough acrylic for one lamp, but many more can be fitted on sections of acrylic. This will save a lot of time, as well as being very efficient.

Base Design

Next is the base. The one originally sketched at the bottom of the page does not provide much support, even when weighted. It is also not very aesthetically pleasing. A new design that provides more support and is more aesthetically pleasing is needed.

The design on the right has a greater surface area touching the desk than the previous one, making it more stable than before. It looks slightly better, but has no significant improvements other than stability.



By cutting sections out of the slanted design, the base looks more like it is part of the product, not just attached as an afterthought. Because of the removed sections, the product will weigh less.



This style of base looks a lot more fitting. It keeps the wide base that provides all the support, but also goes with the shape of the frame and disks. I think that this will be the base for this design due to its looks and functionality.

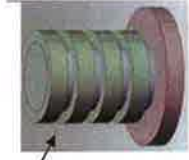

A way to reduce costs is by reducing processes and materials used. By replacing the screw with an acrylic pin, materials can be reused from the CAM process. Threading is no longer needed and so saves money. It will also make the design more aesthetically pleasing as there is no longer a screw there.

Further Base Development

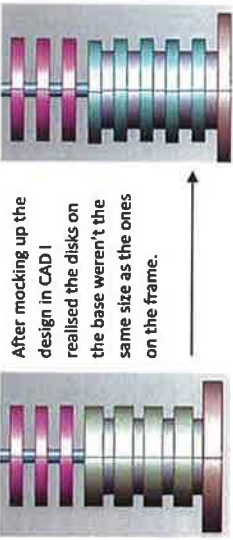

After mocking up the design in CAD I realised the disks on the base weren't the same size as the ones on the frame.

This is just a small issue, but it adds to the overall look

This is a cross section view of the base. Inside it will have two disks made of acrylic or MDF that have holes in the middle which will support the goose neck. Holes will then be drilled into the side of these disks, similar to the disks mentioned earlier, to hold it in place with screws. The space in-between these disks can be filled with sand or metal off cuts in order to weight it and provide extra stability. Finally, at the bottom will be a hole which allows wire to pass through.

Head design

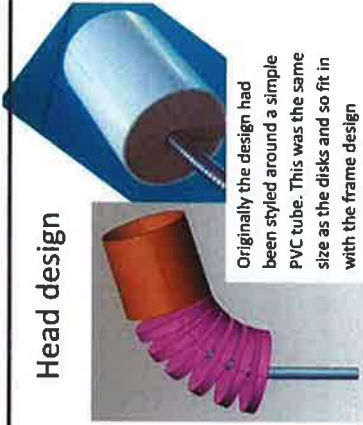

Originally the design had been styled around a simple PVC tube. This was the same size as the disks and so fit in with the frame design reasonably well.

Next is connecting the head of the lamp which will contain the bulb. The head must fit in with the design well, but also do a good job of directing the light in the desired direction. This means a reflector will need to be built in to the head. Also, a way of attaching all this to the goose neck needs to be found, while keeping the lamp compact.

I then experimented with making the head wider. This means that light can be directed over a greater. However, it does not fit well with the design, looking out of place. Also, the extra material may make the product top heavy and unstable.

Height when straightened would be roughly 370mm



Another section of MDF holds the light fitting in place. The inner hole of the MDF is threaded slightly to make sure it stays in place.

Reflectors

The next part is what goes inside the head. A light fitting and reflector must be installed in order to allow easy change of the bulb and good light direction.



The main problem I had with these was that they weren't deep enough to allow the light bulb to fit. I then made some deeper reflectors.



These deep reflectors managed to contain the entire bulb, which will be ideal for directing light in the user's desired direction.

This is my idea for the structure of the head. Starting from where it connects to the goose neck, screws will clamp the head to the goose neck as they do with the base.

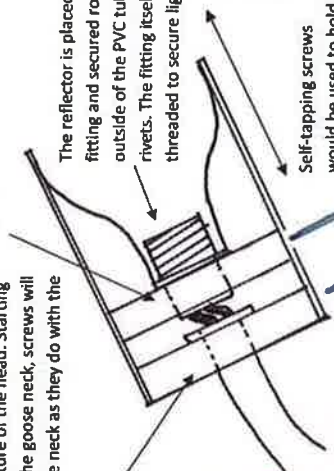

A manufacturing problem I had with the deeper reflectors is that they caused "webbing" when vacuum forming. This is due to the length of plastic stretched over the mould. In production these would be made by injection moulding, as it would prevent this and is cheaper.

Model Refinement

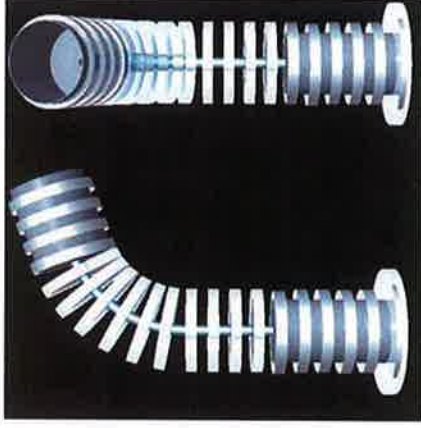

Removing the PVC tube from the base was an idea which at first seemed clever, a larger acrylic disk at the bottom would provide support. It would also save manufacturing costs as more can be cut out using a router. However, after asking people for feedback, I found that many thought it looked rather unstable and flimsy, and would not buy it, regardless of its actual strength or performance.

I made a mock-up of what the final design would look like in CAD, so that anything that stands out as looking odd could be improved upon.

One thing that makes this so bland is the lack of colour. The colour would be carried through the acrylic by refraction, giving a nice design feature that would make it look great on display.

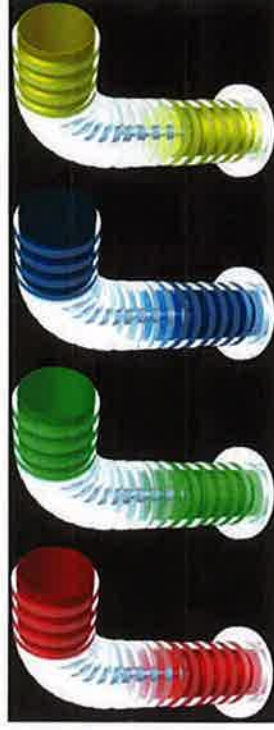

These seemed very effective and many people that looked thought they were a lot more appealing, fulfilling the specification for being aesthetically pleasing. The PVC is easy to colour and so will add only 1 extra step to the manufacturing process which is adding dye to the plastic. The weighted base with extra surface area would provide plenty of support. The head has a good balance between aesthetics and performance, directing light where the user wants it. I feel that this lamp cannot be improved upon.

The light fitting I'm using holds "E27" type lights. These are the most common type of light bulb and come in a variety of shapes. I'm choosing this type of light fitting because it will widen my product market more than if I used a very rare type of bulb. This fitting can also support "energy saving" light bulbs, which make it more environmentally friendly and save the user money over a long term.



Exploded view

This part of the sheet shows an exploded view of how my lamp will fit together. It goes over complex parts in more detail and also talks about certain manufacturing methods.



This is a pilot hole for the self-tapping screws. It is needed to prevent the wood from splitting. There is a pilot hole in each of the wooden disks located in the head and base. The reason these parts are shaped like this is to make maximum use of the space available inside the PVC tube, so as much light as possible can be directed

Inside are the steel wire and the cables providing electricity. This makes the design look clean and well thought out as no wires are showing.

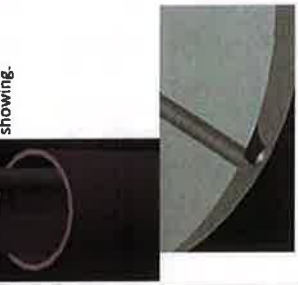

Evaluation of Final Design

To evaluate my design I will compare it to the specification I was given and comment on how it fulfils or fails to fulfil the points listed.

Must be Aesthetically Pleasing:

After many aesthetic improvements from the original design, this is the lamp I have come up with. While designing this lamp I had a target market in mind from late teens to late 30s age group. Changing to clear acrylic disks gives the lamp a futuristic look, with the disk design extending from top to bottom. The coloured PVC tubing at the top and bottom adds to the overall look, by reflecting off the acrylic. The base blends in very well, while also being very functional. The only downfall to this design is that dust will be easily spotted on the clear acrylic, but this is solved by simply using a tissue to wipe the disks when desired.

Must be Safe to Use:

All the electrical wires and connections are contained within the lamp itself. No wire is exposed to view apart from the connection with the plug. The light fitting is contained in the head housing which is sealed off. During the cutting process the acrylic disks will be given a very slight chamfer to avoid sharp edges which could be dangerous. The wide base part provides stability which will prevent it from falling over and damaging its-self or other objects.

Must be Adjustable and Easy to Operate:

The gooseneck gives a very wide range of movement. This allows the user to direct light from very sharp angles near the base, all the way up to the ceiling. It can also be bent in various patterns due to its flexibility. The reflector in the head directs more light to where the user wants, making the directed area brighter. The light fitting takes the most common type of bulb, so the user can select the bulb for their needs. This means that the lamp will seem attractive to users as different bulbs can give it a variety of uses, opening it up to a wider market.

Must be Suitable for Volume Production:

All of the acrylic pieces will be cut out from a single acrylic sheet using CAD/CAM. This is a very efficient volume production method which is both fast and accurate. The pins which hold the disks in place save time and material as no holes need to be drilled or threaded for screws, the pins are also made from the acrylic sheet using CAM. Buying long pieces of tubing and gooseneck in bulk and cutting at the desired length saves money and time. All of these parts are easily assembled as they can slide over the gooseneck one at a time. All this money saving means that the final product will be cheaper and so gain more market share.

Intended Purpose:

The majority of parts used in this design are for aesthetic purposes. The acrylic makes the design look futuristic, while being a cheap material that is easy to work with. Other see through materials, such as glass, are hard to work with and cost more in terms of buying the material itself and cutting to size. The PVC pipe will be able to withstand the heat of the light bulb and the pressure applied from holding the frame in place. Overall I feel these are the most appropriate materials for this design.

The inside of the reflector will be sprayed a metallic silver in order to focus as much of the light produced as possible. The reflector is made by injection moulding HIPS.

When the reflector is combined with the light fitting and its holder, it will look like this inside the head. The light fitting will have a thread around the outside of it, so that it can be securely held in place by its wooden holder. The reflector is held in place by glue between it and the PVC head.

Surrounding disks

All of the screws in the lamp will be threaded, and feature a Phillips head on them. This is so that, if they are damaged they can be replaced. The self-tapping ones will be more pointed at the front to insure they don't split the wood, which would reduce durability.

The light fitting and screws will be brought in from suppliers. Otherwise too much equipment will be needed, meaning a higher maintenance cost.

Light fitting holder

Self-tapping screws

Acrylic disks

Acrylic pins

PVC head

Gooseneck to head attachment

Gooseneck

PVC base

Acrylic base

Gooseneck to base attachment

Reflector

Light fitting

Light fitting holder

Self-tapping screws

Acrylic disks

Acrylic pins

PVC head

Gooseneck to head attachment

Gooseneck

PVC base

Acrylic base

Gooseneck to base attachment

Reflector

Light fitting

Light fitting holder

Self-tapping screws

Acrylic disks

Acrylic pins

PVC head

Gooseneck to head attachment

Gooseneck

PVC base

Acrylic base

Gooseneck to base attachment

Reflector

Light fitting

Light fitting holder

Self-tapping screws

Acrylic disks

Acrylic pins

PVC head

Gooseneck to head attachment

Gooseneck

PVC base

Acrylic base

Gooseneck to base attachment

Reflector

Light fitting

Light fitting holder

Self-tapping screws

Acrylic disks

Acrylic pins

PVC head

Gooseneck to head attachment

Gooseneck

PVC base

Acrylic base

Gooseneck to base attachment

Reflector

Light fitting

Light fitting holder

Self-tapping screws

Acrylic disks

Acrylic pins

PVC head

Gooseneck to head attachment

Gooseneck

PVC base

Acrylic base

Gooseneck to base attachment

Reflector

Light fitting

Light fitting holder

Self-tapping screws

Acrylic disks

Acrylic pins

PVC head

Gooseneck to head attachment

Gooseneck

PVC base

Acrylic base

Gooseneck to base attachment

Reflector

Light fitting

Light fitting holder

Self-tapping screws

Acrylic disks

Acrylic pins

PVC head

Gooseneck to head attachment

Gooseneck

PVC base

Acrylic base

Gooseneck to base attachment

Reflector

Light fitting

Light fitting holder

Self-tapping screws

Acrylic disks

Acrylic pins

PVC head

Gooseneck to head attachment

Gooseneck

PVC base

Acrylic base

Gooseneck to base attachment

Reflector

Light fitting

Light fitting holder

Self-tapping screws

Acrylic disks

Acrylic pins

PVC head

Gooseneck to head attachment

Gooseneck

PVC base

Acrylic base

Gooseneck to base attachment

Reflector

Light fitting

Light fitting holder

Self-tapping screws

Acrylic disks

Acrylic pins

PVC head

Gooseneck to head attachment

Gooseneck

PVC base

Acrylic base

Gooseneck to base attachment

Reflector

Light fitting

Light fitting holder

Self-tapping screws

Acrylic disks

Acrylic pins

PVC head

Gooseneck to head attachment

Gooseneck

PVC base

Acrylic base

Gooseneck to base attachment

Reflector

Light fitting

Light fitting holder

Self-tapping screws

Acrylic disks

Acrylic pins

PVC head

Gooseneck to head attachment

Gooseneck

PVC base

Acrylic base

Gooseneck to base attachment

Reflector

Light fitting

Light fitting holder

Self-tapping screws

Acrylic disks

Acrylic pins

PVC head

Gooseneck to head attachment

Gooseneck

PVC base

Acrylic base

Gooseneck to base attachment

Reflector

Light fitting

Light fitting holder

Self-tapping screws

Acrylic disks

Acrylic pins

PVC head

Gooseneck to head attachment

Gooseneck

PVC base

Acrylic base

Gooseneck to base attachment

Reflector

Light fitting

Light fitting holder

Self-tapping screws

Acrylic disks

Acrylic pins

PVC head

Gooseneck to head attachment

Gooseneck

PVC base

Acrylic base

Gooseneck to base attachment

Reflector

Light fitting

Light fitting holder

Self-tapping screws

Acrylic disks

Acrylic pins

PVC head

Gooseneck to head attachment

Gooseneck

PVC base

Acrylic base

Gooseneck to base attachment

Reflector

Light fitting

Light fitting holder

Self-tapping screws

Acrylic disks

Acrylic pins

PVC head

Gooseneck to head attachment

Gooseneck

PVC base

Acrylic base

Gooseneck to base attachment

Reflector

Light fitting

Light fitting holder

Self-tapping screws

Acrylic disks

Acrylic pins

PVC head

Gooseneck to head attachment

Gooseneck

PVC base

Acrylic base

Gooseneck to base attachment

Reflector

Light fitting

Light fitting holder

Self-tapping screws

Acrylic disks

Acrylic pins

PVC head

Gooseneck to head attachment

Gooseneck

PVC base

Acrylic base

Gooseneck to base attachment

Reflector

Light fitting

Light fitting holder

Self-tapping screws

Acrylic disks

Acrylic pins

PVC head

Gooseneck to head attachment

Gooseneck

PVC base

Acrylic base

Gooseneck to base attachment

Reflector

Light fitting

Light fitting holder

Self-tapping screws

Acrylic disks

Acrylic pins

PVC head

Gooseneck to head attachment

Gooseneck

PVC base

Acrylic base

Gooseneck to base attachment

Reflector

Light fitting

Light fitting holder

Self-tapping screws

Acrylic disks

Acrylic pins

PVC head

Gooseneck to head attachment

Gooseneck

PVC base

Acrylic base

Gooseneck to base attachment

Reflector



Screw

The screws and pins were drawn separately as they would not show up on the drawings.

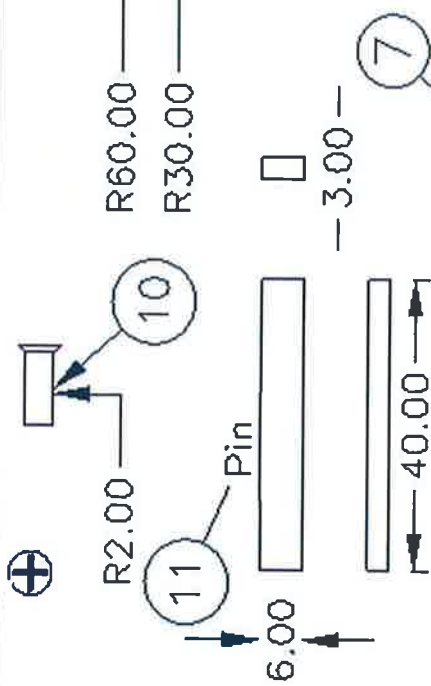

Part Number	Component	Quantity
1	Acrylic Disk	10
2	Goose Neck	1
3	PVC head	1
4	Acrylic Base	1
5	PVC Base	1
6	Acrylic Ring	9
7	Reflector	1
8	Light Fitting	1
9	Head Attachment	2
10	Screw	9
11	Pin	10



This is an Orthographic Projection of the lamp; it shows important measurements that are needed for it to be reproduced accurately.

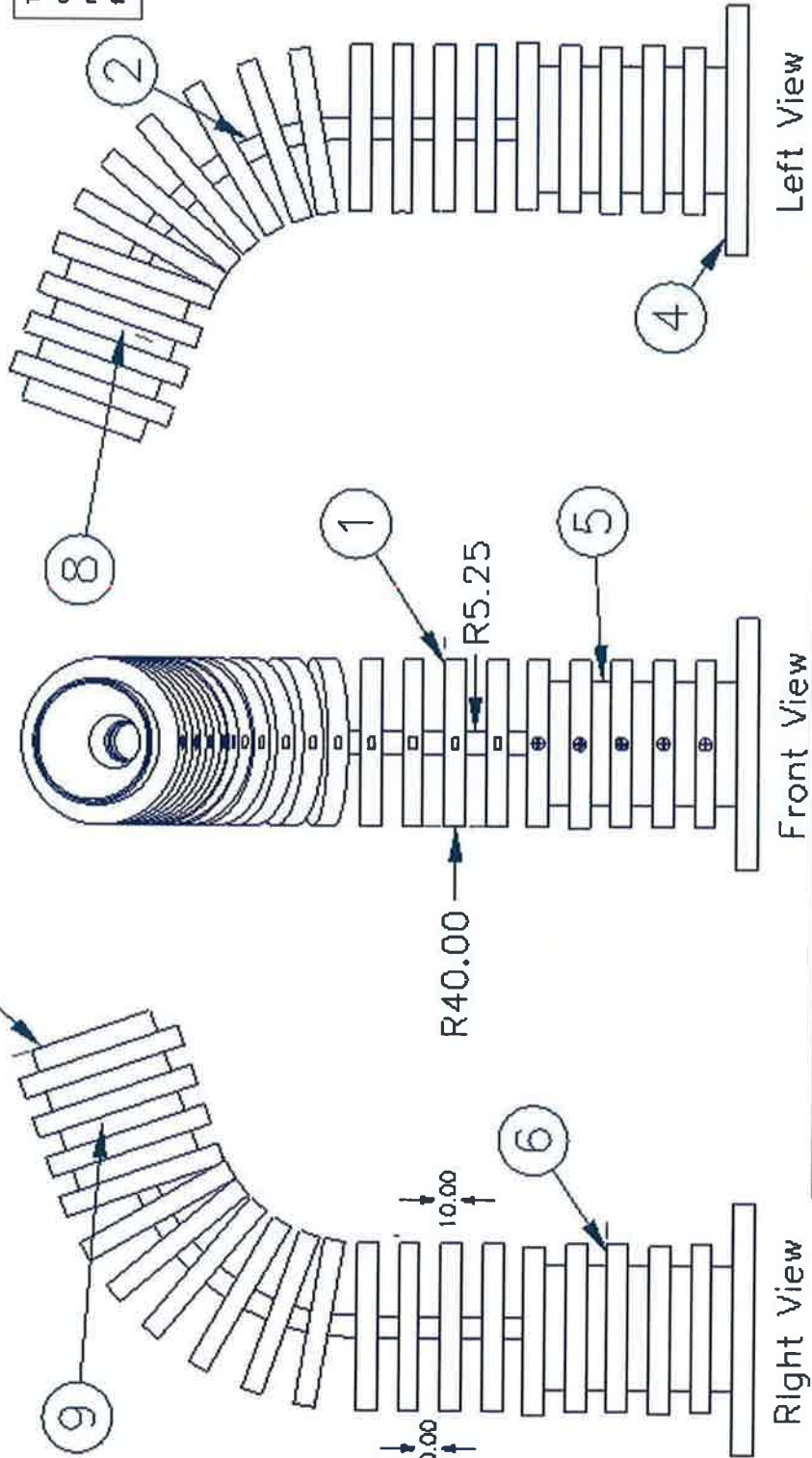
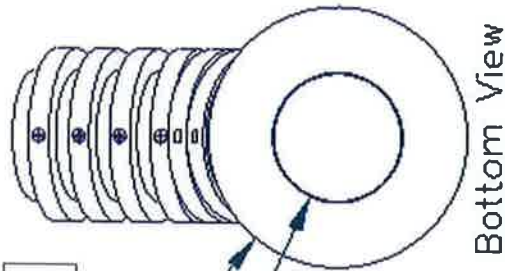

Evaluation

3rd Party Feedback:

I asked friends and family members to comment on the design. I questioned them on whether or not they would buy it, and why. Anything they liked or disliked, and what kind of price range they would expect it to be in.

Would you buy it?

The overall response for this question was yes, from all age groups. People went on to say that this is a more interesting design than what you would typically see in a mainstream store such as IKEA, and that they would highly consider buying this product. However, a few said that if they were shopping for specialist/designer lighting this would not be at the top of their list. The reason being that "it looks like it's trying to be lots of styles in one". This is a fair comment as it is a mix of a few styles such as contemporary/futuristic. The product is designed for mainstream shops and the feedback shows that it will do very well in that market as "it looks more interesting than normal lamps".

Anything you like or dislike?

Many people liked the idea of a very flexible lamp. "It looks complicated, but simple at the same time" was one comment it received. People liked the fact that any light bulb could be used with it. The majority of positive comments came from the looks. The way that the disks moved with the lamp as it was adjusted fascinated some of the younger people that viewed the lamp. Some liked the idea of a variety of colours, saying that if it was just one colour they may not have liked it so much. One complaint that someone had was that they could see it collecting lots of dust over time. Dust would collect on the disks and be very visible due to the acrylic being see-through. It would also be hard to clean near the centre of the disks. One person said they didn't like it as it seemed like too much was going on, "there's so many separate parts". This is a fair comment, although somewhat based on the persons preferences.

What price would you expect?

Many said that if it was on sale at a place like IKEA, they would expect the price to be near the top of all the lamps they sold. If it was sold in a designer shop they would expect it to be middle to low range in price. Many emphasised that they wanted value for money. They didn't want to pay a premium on something that looks fancy, but was actually poorly made and does the same job as products half its price or less. When I told them that I had aimed it at the middle of the mainstream market, they seem delighted. This was possible through efficient use of automated processes such as CAD/CAM, and minimising the number of production processes needed. This only increased their thoughts of buying it had it been a real product.

Improvements:

After reviewing the final design and listening to user feedback, there are a few areas where this lamp can be improved upon.

The Frame:

Whilst questioning people someone had mentioned the problem of dust. This is something that I hadn't thought of while developing the lamp. The only way to make this less of a problem without drastically changing the lamp design is to remove one or two of the disks. This would make it easier to clean the disks with something like a tissue, as there would be more space to fit fingers in between.

The Head:

One issue I came over when examining a lamp at home is that gets hot. Although many of the lamps are made of plastic, the ones that use more powerful bulbs have metal reflectors. For my product I would either need to state a maximum power rating for the bulbs, or consider making a metal reflector for the inside of my lamp. These could either be cast or done on a CNC lathe, however for production purposes they would be brought in from a supplier.

The Base:

Having looked at the product for a while in the form of CAD modelling, it does start to look unstable after considering the weight of the head once it contains the light bulb, fitting, reflector and two MDF disks. If the lamp was bent over fully it may have a tendency to topple, causing damage to the lamp. If I were to design it again I would make the base wider, so that it could support the lamp being bent at greater angles.

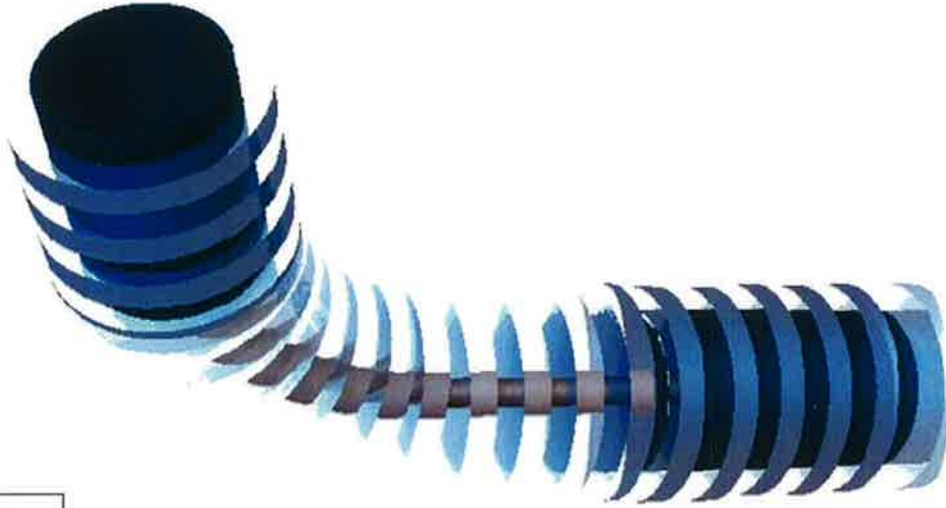

GCE in Design Technology

(AS) Product Design – Resistant Materials Technology

Unit 1 – Portfolio of Creative Skills (6RM01)

Product Manufacture

Flow Chart

Turning/threading Bolts

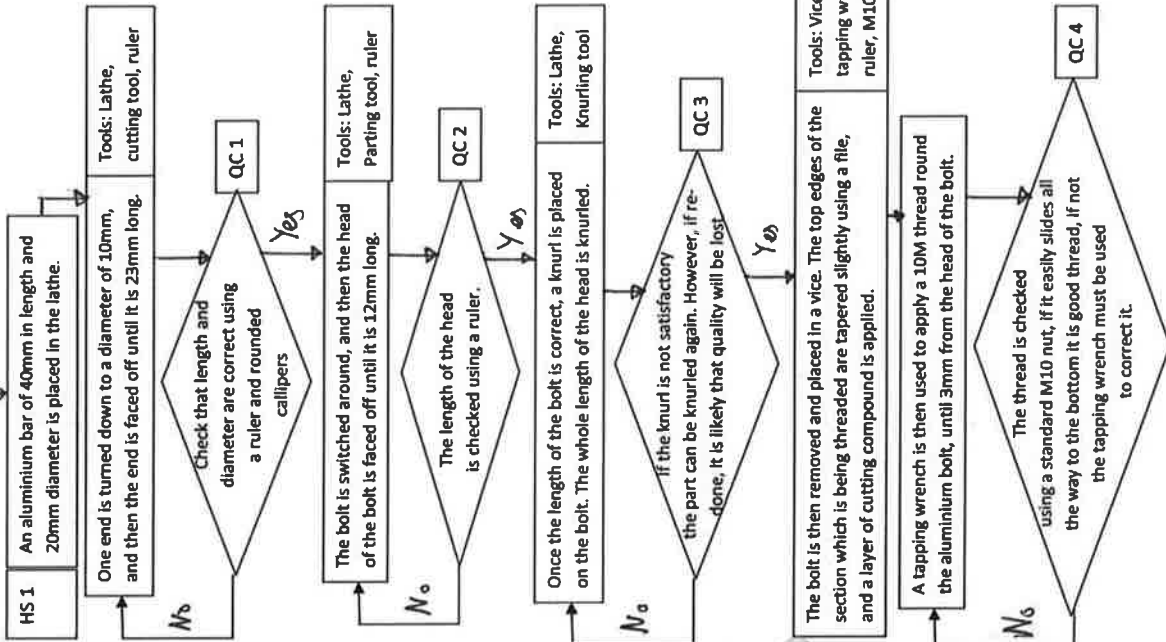

Marking out and cutting finger joints

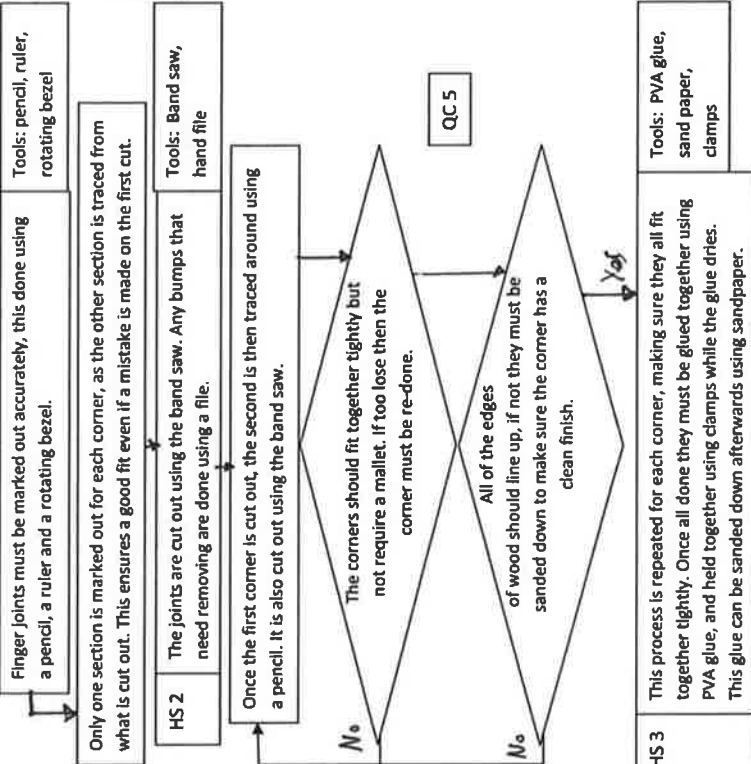

HS 1

The main aluminium part of the handle can be turned on the lathe. It is first measured to check the diameter and length is correct. If not, the aluminium bar will be turned down and faced off. After this, a knurl will be applied to the entire length of the bar.

Tools: Lathe, cutting tool, ruler, knurling tool

QC 6: If the knurl is not up to standard, then it must be re-done. If not correct the second time, a new piece must be used

QC 7: A hole must be drilled down the centre of the handle, this is done using an 8.5mm drill bit, so that tapping the inside of the hole is possible. The drill bit is secured in the tail stock and slowly cuts into the bar. The ends of the bar are then switched, and are similarly knurled and drilled.

Tools: Lathe, tail stock, drill bit

QC 8: After this, a thread must be applied to the inside of the hole. This is done using a threading bit and a wrench.

QC 9: The thread is tested by screwing a standard 10M bolt into the handle after every 10mm of threading, this is to insure the thread is of high quality.

HS 4: The 2nd and 3rd part of the handle are the connecting iron bars. These need to be bent using the oxy-acetylene gun. They are heated to a bright red colour, and then hammered till they are at a 90 degree angle.

Tools: oxy-acetylene gun, hammer, vice, engineers square

QC 10: The angle of the bar is tested using an engineer's square, if the bar is not 90 degrees, it must be reheated and hammered until that angle is reached.

QC 11: Next the bars must be threaded at each end. The thread is applied to the steel bar while it is in a vice. The thread is done to the desired length at each end.

QC 12: The thread is tested by screwing a standard 10M nut over the bar after every 10mm of threading, this is to insure the thread is of high quality. If not, the thread can be re-done.

Brazing

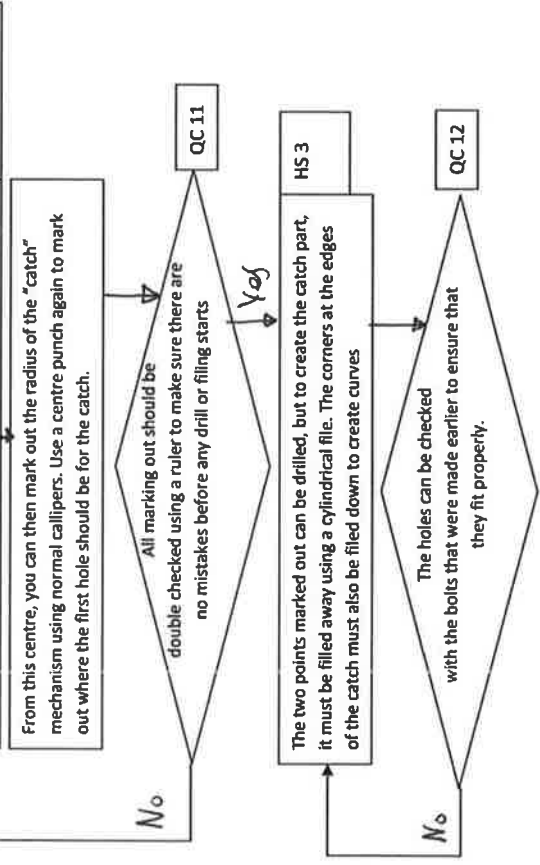
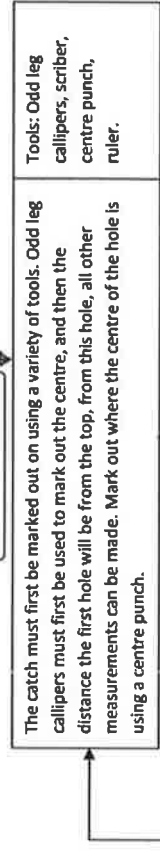
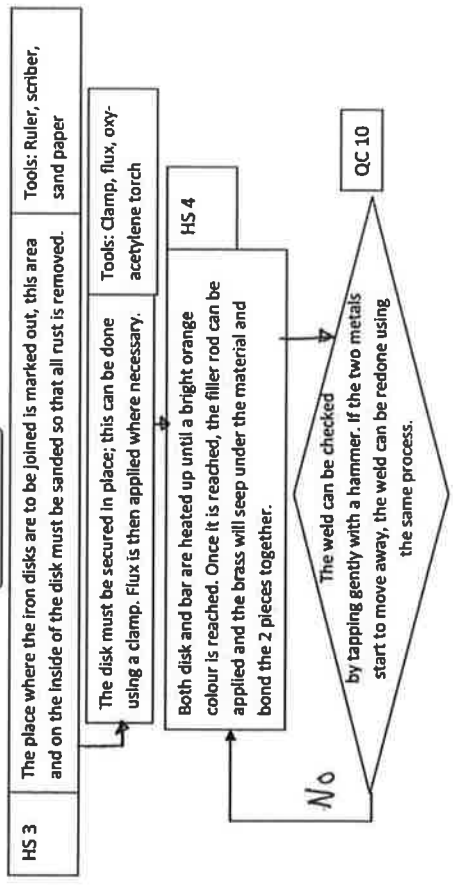

Removing Wood for Hinges

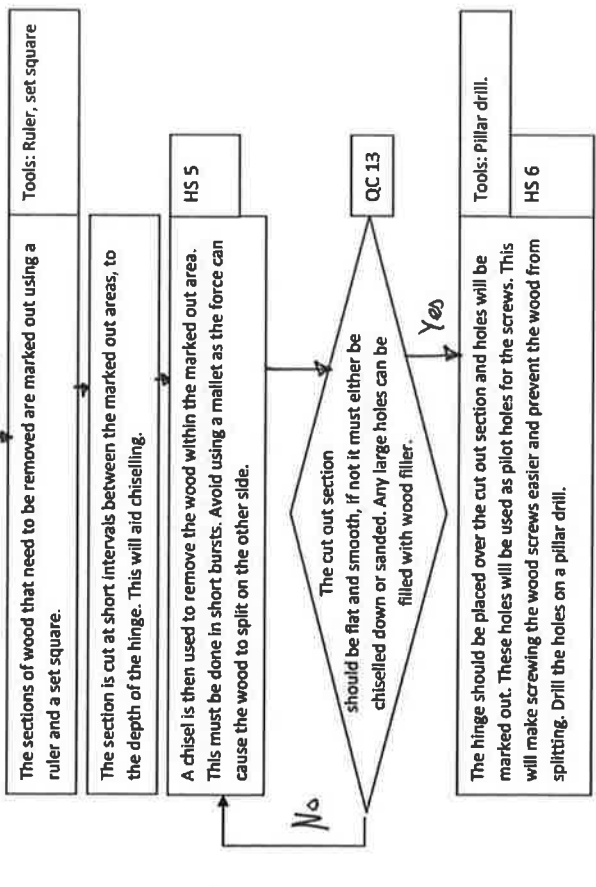

Quality Control

Quality Control Code	Identify Reason for check	How the check has been achieved
QC1	To ensure that the parts of the product will fit together properly once assembled.	Once everything has been marked out, it must be checked using a ruler to make sure it all fits properly.
QC2	To make sure the parts are of similar dimensions.	The length is checked periodically as it is turned down, once it starts to get close to the desired length smaller sections are cut off.
QC3	This part of the product is used frequently and it is important that the knurl is consistent throughout.	By comparing visually with other knurls, I can tell if the knurl meets expectations. A similar approach can be done from touching.
QC4	The thread must be accurate in order for the product to be assembled properly.	By screwing a standard nut of 1.5 pitch over the thread, I can tell how well done the thread is by how easy it is to turn the nut to the bottom.
QC5	If the sections of wood do not line up, the product will look poorly made. It may also weaken the product and cause possible damage.	This can be checked visually and by hand. Any parts of wood sticking out will be felt and can be sanded down accordingly.
QC6	This part of the product is used frequently and it is important that the knurl is consistent throughout.	By comparing visually with other knurls, I can tell if the knurl meets expectations. A similar approach can be done from touching.
QC7	The thread must be accurate in order for the product to be assembled properly.	By screwing a standard nut of 1.5 pitch over the thread, I can tell how well done the thread is by how easy it is to turn the nut to the bottom.
QC8	If the angle is not correct, the product will not fit together properly. It will also look odd as people will be able to tell it is not at a right angle.	After forging the metal and letting it cool, an engineer's square can be used to check that it is exactly 90 degrees.
QC9	The thread must be accurate in order for the product to be assembled properly.	By screwing a standard nut of 1.5 pitch over the thread, I can tell how well done the thread is by how easy it is to turn the nut to the bottom.
QC10	The weld must be strong. If it is not the two pieces of metal will separate and could damage the box or harm the person using it.	By clamping one part of metal and lightly hammering the other, we can verify its strength. If cracks form, it is not strong enough.
QC11/ QC12	This part must have accurate dimensions as it secures the two sections of the box together. If it is the wrong size, the catch may not fit or fit too loosely.	By double checking all measurement, and checking after metal has been cut off, we can make sure the catch is the exact size.
QC13	The wood must be flat for the hinges or else the box will not close properly. It may also look bad from the outside if the wood is uneven.	The small cut intervals should have disappeared, if some are still visible it shows the wood has been chiselled unevenly and needs to be redone.

Health and Safety

Health and Safety Point	Process	Health and Safety Procedures
HS 1	Use the Lathe to turn down, drill holes into and knurl aluminium bars.	The fast rotating metal bars can be dangerous if not secured correctly. The chuck must be tightened properly before use to avoid this. Goggles must be worn for eye protection as off cuts can fly off in all directions, usually being sharp. An apron must be worn to prevent any loose clothing being tangled in the chuck or any levers on the lathe.
HS 3	Filing and sanding wood and metal	These processes must be carried out in a well ventilated area, as dust can cause coughing and lead to more serious problems after long periods of exposure. When filing and using rough sand paper, it is important to keep your hands away from the area being filed to avoid cuts or scratches.
HS 5	Chiselling wood to make room for hinges	It is important to make sure the chisel is always facing away from you. If you are hammering a chisel towards you and it slips, and can cause serious injury. Make sure the space you are working in is clear so that you aren't knocked by anyone.
HS 4	Brazing and forging metal	Tinted goggles should be worn to prevent eye pain and the chance of retinal scarring. The space you are working in should be clear, with nothing lying on the floor that could cause you to trip up. The area should be well ventilated.
HS 6	Drilling holes into wood and metal	An apron should be worn and hair should be tied back to avoid being tangled in the drill. Eye protecting should be worn to prevent any debris that flies off from hitting the eye.
HS 2	Cutting wood on a Band-Saw	An apron and goggles should be worn, as well as hair tied back. The blade cover should be adjusted to the correct height. Push sticks must be used for small pieces of wood to prevent damage to fingers.

Scales of Production

The scale of production for this product would most likely be batch production, as large quantities need to be made but only if enough resources (mainly wood) are available. The difference between this batch production and a one off production in a school work shop are that the machines are automated and controlled by CAD programs. This automated machinery would require the planning and design of the product to be different. It would be made in ways more suited to CNC machines, than to workshop tools. The order of what part is made first would change so that the product can be made more efficiently, taking up less time. Overall, this type of production would be much more accurate when compared to a school workshop, as the machines are controlled by computers, compared with a person's eye sight when using workshop tools.

Gantt Chart

Start Date:
30/3/09

Finish Date:
11/4/09

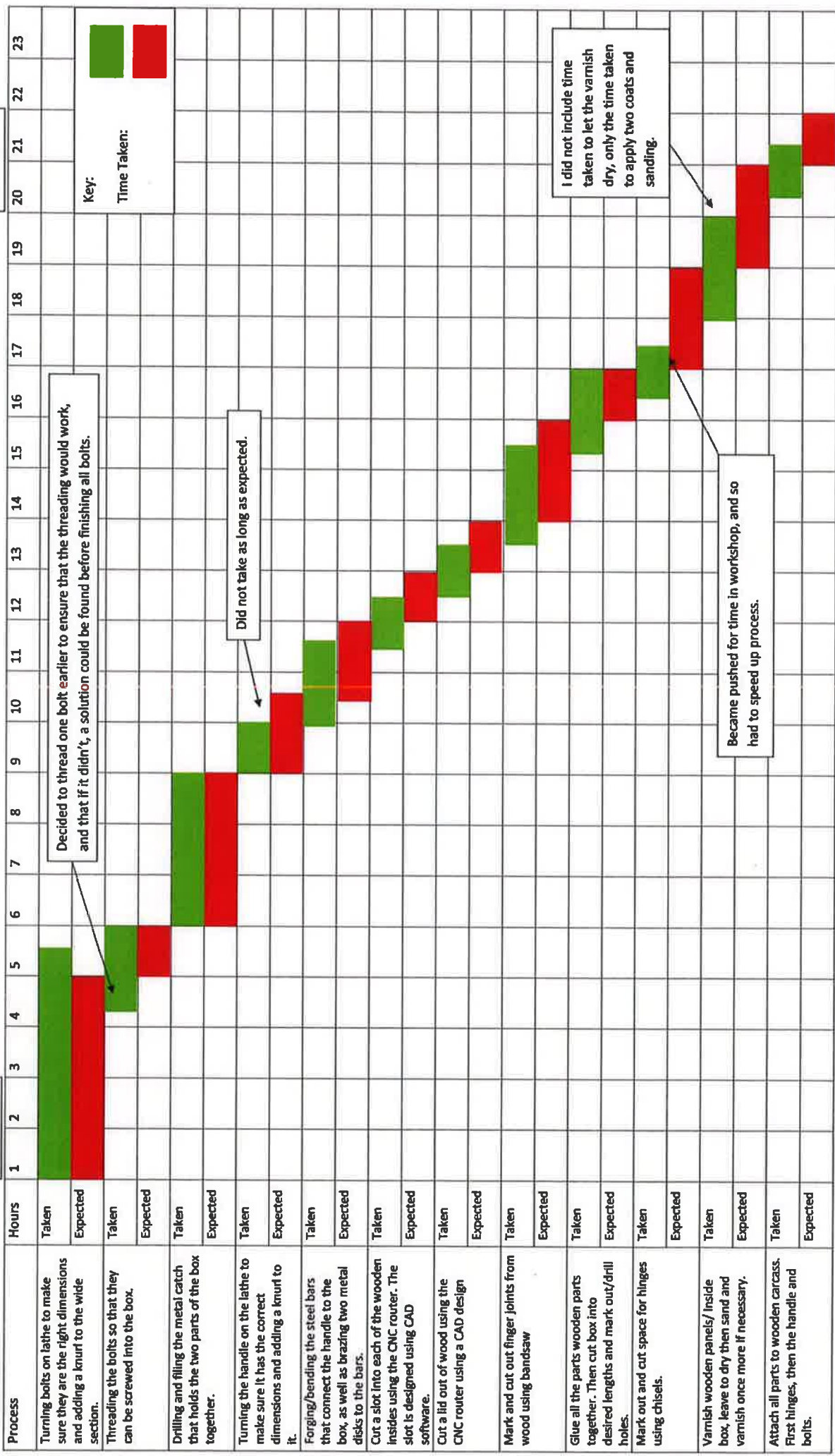

Decided to thread one bolt earlier to ensure that the threading would work, and that if it didn't, a solution could be found before finishing all bolts.

Did not take as long as expected.

I did not include time taken to let the varnish dry, only the time taken to apply two coats and sanding.

Became pushed for time in workshop, and so had to speed up process.

Reasons for Material and Process Choices

Material /Process	Properties	Working Characteristics	Reason for Choosing Material/Process
Rubber Wood – For carcass	Rubber wood is a type of manufactured board. It is made from small planks of timber that have been stuck together. This makes it cheap and available in large sheets. Although it is manufactured, it looks quite aesthetically pleasing due to the different grains which are exposed on the surface of the wood. It also varnishes well.	As it is manufactured, there are a very low number of knots in the wood. This makes the hardness and strength of the wood very predictable. However, as the board is made from strips of wood glued together, where they meet can be harder to saw through due to the glue used. Overall it is very easy to saw through and drill into.	The reason I am using this material instead of other woods is due to a few reasons. Firstly, it comes in large boards, where as many woods come in planks that would require gluing together. Secondly, as it is made from strips of wood, it has a nice aesthetic finish which other manufactured boards don't, due to the exposed grain. It is also easy to work with and finally is cheap in comparison to other woods.
Aluminium – For bolts, handle and catch	Aluminium is a lightweight metal; it has a low melting point and is soft in comparison to metals like iron and steel. It is readily available in a variety of shapes and sizes from bars to sheet metal. As it is quite common and light weight, it is a cheap metal. However, it is not the strongest of metals.	Aluminium is easy to work with due to being less dense than other metals. It can be cut easily and lathe work is fast and efficient as it does not blunt any tools as quickly unlike iron or steel.	Aluminium is great for use on the lathe, as it is easily shaped and will not blunt the tools. As the majority of parts I am making will require lathe work, aluminium seems like a sensible choice as it will save time and give a good finish with no further sanding. It is also used for the catch, this is because it is easy to file away and drill into, speeding up the time taken to make those parts.
Iron – For connecting handle to carcass	Iron is much stronger than aluminium, which means that smaller sections of it can be used to maintain a similar strength. One problem is that its appearance is dull to oxidation and rust. However, this can be fixed with paint or chroming.	It is a hard material to work with due to its strength. It also has a high melting point. Can easily blunt lathe tools.	Due to it being strong, it is great for applications that will put the material under stress. Connecting the handle to the carcass is an ideal use for this material, as thin bar can be used, without the worry of it bending. It can also be heated up and bent using the oxyacetylene torch. It is easy to bend when heated in this way, which is ideal for the application I want to use it for.
Finger Jointing	Finger joint is a method of joining wood together. A series of sections are cut out of two wooden pieces and then joined together in an interlocking type pattern with glue. The result is a strong joint that also looks good.	This method of joining takes longer than other methods of joining. This is due to the amount of marking out required, as well as the time taken to cut out individual sections and then file them down so that each section of wood fits firmly together, but without splitting the wood.	This joint is chosen because it provides a very strong join between two pieces of wood, but also provides a very aesthetic join. As these joints will be easy to see, this is ideal. The extra time taken is not that significant as I am in no rush to build it.
Brazing	This process uses high temperature and brass filler to bond to pieces of metal together; it provides a decent amount of strength and looks clean once filed/sanded down.	It requires the surfaces that are being joined to be smooth and free of rust. The overall process is fast, and the result is a relatively strong bond.	The main reason for choosing this method over arc welding is due to the aesthetics. Brazing leaves a nice finish as it is bonded throughout the whole contact area of the join, not just round the edges as with arc welding. The same applies to MIG welding. It is also easy to sand down the brass filler afterwards as it is not a particularly hard material.
Lathe Turning	The lathe is a way of working on cylindrical objects very accurately. It takes a variety of diameters, and can also be modified to work on square or other symmetrical shapes. There are a variety of tools that can be used with the lathe, this makes it very versatile.	The wide arrays of tools that can be used with this machine mean that a large number of processes can be carried out on it. It is possible to work with hard materials on the lathe, such as steel, due to the hardened tools that are used. Changing tools is very fast and efficient, resulting in the job being done a lot quicker. The lathe is also very precise, as measurements can be taken by 0.1mm.	As I am making four bolts that need to be identical, the lathe is an ideal machine to use due to its ability to make such fine adjustments to the cutting diameter/depth. The automatic feed tool gives a very consistent finish that does not require any further touching up. As I will be working with aluminium, the process will be very efficient given the strength of the tools used. The ability to knurl components means that the overall product will appear to have a greater quality finish.

Risk Assessment and COSHH

Risk assessment is based on a 5 by 5 table, likelihood on one side and severity on the other. The dangers of different processes vary and are given a ranking out of 5, from 1 being unlikely or small scratches, to 5 being bound to happen or death possible.

Process	Potential Hazards	Safety Precautions	Likelihood (out of 5)	Severity (out of 5)	Rating (out of 25)
Forging/Brazing	<ul style="list-style-type: none"> Burns from the flame or hot pieces of metal are possible due to the very high temperature of the oxy-acetylene torch. The most likely way to receive burns is from pieces of metal that are no longer glowing but still very hot. Damage to the eye can be caused from the bright blue flame used to heat the metal. 	Make sure that hot metal is either cooled immediately or put to one side where no one is likely to touch it. Tinted goggles can be worn when heating the metal up.	3	4	12
Lathe Turning	<ul style="list-style-type: none"> Off cuts produced can be sharp and quite hot. It is possible that either the lathe tools or the piece being worked on snap when put under heavy strain. Due to the high spinning speed this can cause sharp "projectiles". Tools are heavy and frequently changed possibility of being dropped on feet. 	Do all the required safety checks before operating the machinery. Make sure work piece and tools are secured, and do not cut off too much material at once. Wear eye protection.	3	3	9
Filing	<ul style="list-style-type: none"> If the file slips off the work it could cause the hand to hit the vice and bruised or damage some skin 	Don't file too fast. Make sure the parts are secured in a vice.	2	1	2
Cutting on wood band saw	<ul style="list-style-type: none"> Cutting fingers on lathe is possible if fingers slip off the side of wood that is being cut. Inhaling wood dust can cause coughing; more serious problems arise after prolonged exposure. Bodily ache from prolonged exposure 	Use a "push stick" when dealing with small pieces so that hands are kept away from the blade. Make sure the blade cover is only as high as it needs to be. Wear eye protection.	3	4	12
Drilling holes for latches	<ul style="list-style-type: none"> Drill can snap if too much force is applied. Metal can start to spin round and fly off drill if not properly secured. Sharp off cuts can fly out. 	Clamp work down using G-clamps. Wear safety goggles and drill into work at realistic speeds.	4	2	8
Using a chisel to cut slots for hinges	<ul style="list-style-type: none"> Dropping chisel can cause damage to feet. Chisel can slip off wood and cut skin Thumb can be caught between the handle of the chisel and mallet 	Make sure that the chisel is always facing away from the body/hands. This will reduce the chance of get cut if chisel slips off wood.	3	3	9

There are certain precautions that must be obeyed in order to ensure a safe work space regardless of the process being carried out. All these precautions are filed under COSHH regulations. They cover a wide range of processes and materials, with recommended safety precautions that should be followed.

1.058 COSHH REG wood working: Dust

- Eye protection should be worn at all times and exhaust ventilation must be provided to control and regulate dust at its source.
- Dust masks at standard FFP1 should be worn with high exposure to dust. Duration of longer than 15 minutes require a higher regulation mask, particularly if working with manufactured board.

1.032 COSHH REG Metal Working Machines

- Long hair should be tied up and any dangling objects should be removed. An apron or overall must be worn at all times especially when loose clothing/ attire is worn. Proper footwear should be worn to reduce accidents.
- Adequate amount of space should be given around the machines. Guards over moving equipment will minimise the risk of trapping as well preventing objects from flying off which will ensure the safety of others as well as yourself.

Along with these are basic rules that should be followed. Most of these practices are based on common sense and are carried out normally in the workshop, however they are still important:

- An apron should be worn whilst in the workshop in order to keep loose clothes away from machinery, as well as to keep clothes clean.
- Goggles should be worn with all machinery that produce debris, or that require the user to look closely at the material being worked on.
- Long hair should be tied back.
- Any processes involving heat treatment should be done with tinted goggles due to the bright light produced from the equipment.
- Proper footwear covering the whole foot should be worn to minimise damage in case tools/materials are dropped.
- Make sure there is good ventilation around processes that produce dust.

Manufacture of Box



The picture to the left shows turning down. This process involves slowly cutting off thin "layers" of aluminium. It is used to get the desired thickness of the bar. Once complete, the thickness is checked with a ruler and callipers.

The first process I started was the lathe work. This involved turning down, facing off and knurling certain pieces of work.



The knurling pictured above is a quick process. However it had to be redone as the knurl was not satisfactory at first.

The bolts are threaded. This is done using a die and a die stock. It is important to make sure that the die is at a 90 degree angle to the bolt being threaded; otherwise the thread will be slanted and will make it hard to use the bolt in the desired hole.



To the left is a quality control check. A standard nut is used to test all of the threaded parts, by twisting it all the way to the bottom. This insures that the thread is done to a high standard, and that the bolt should be easy to attach to the product.



Before filing, the desired curve is marked out on the aluminium using callipers. Firstly, aluminium is removed using a dreadnought file, pictured below. Once a lot of material is removed, a normal file is used to clean up the edges and get it into the desired shape.



Once completing one catch, I filed the second by placing the two together and filing up to the edge of the first. This ensures that both will be the same shape.



After this, the catches are sanded with coarse sand paper then fine sand paper. The fine sand paper is wet first, as this gives the metal a smoother finish and prevents dust. It then needs to be rinsed to remove any remaining dust.

Forging requires heating up the steel bar until it glows a cherry red, using an oxy-acetylene torch. Once it has reached this, the bar must be hammered to the correct angle and checked with an engineer's square.



Brazing uses a brass filler rod and flux, as well as the oxy-acetylene torch. The areas being bonded must be cleaned first and then heated till the parts glow red. Then the filler rod can be applied along with flux, and left to cool.



The hinges are first marked out as shown on the left. They are marked out using a ruler and a set square. To cut out the hinges I used a chisel and a saw. I used a saw to cut the section into smaller parts, this makes it easier to remove with a chisel after, as shown in the two pictures below. A band saw could have been used for this process, but it would not give the same accuracy and could cause the wood to splinter.



The joints are cut out on a band saw. The straight lines should be cut out without using anything to aid keeping the wood straight. This is because the aids will not be exactly 90 degrees and so it is best to do it by hand. Once one joint is cut out, the next is marked out from that joint. This means that the joint will fit together better, even if the saw did not follow the marking. The resulting joint should fit together tightly, but without needing a mallet to push the parts together.



Before attaching the hinges I needed to drill pilot holes. This insures the wood doesn't split due to the width of the screws.



When screwing the screws in, it is important not to apply too much force. If the screw is resisting being tightened, it's a sign that the pilot hole is not big enough and that the wood may split. This could also strip the screw head.

These pictures to the right are screen grabs of the CAD drawings for the lid and the slot on the inside of the box. The lid has a section cut out round the edge where it overlaps the sides of the box. The slot on the box panels is to fit the base of the box in. Once it is assembled, the base will fit securely. These designs are transferred to the CNC software that controls the router, and cut out on the router.



The finger joints are marked out with the aid of a sliding bezel. This tool maintains the angle at which a line is drawn. This is important for accurate marking out of the joints.

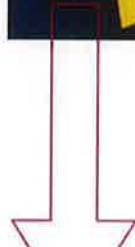

Testing

Specification for the A3 Storage Box:

1. Be made using a diverse range of practical skills, processes and techniques.
2. Be economically/logically assembled.
3. Suitable for batch production.
4. Finished to a high quality.
5. Manufactured from a range of resistant materials that are suitable for its intended purpose.
6. Hold and store paper of A3 size.
7. Open easily and be secure when transporting.

Specification Point	Testing	Result
1	By reviewing previous sheets, it is apparent that a large range of processes are used. Various techniques are used for the different materials involved, proving to be effective ways of accurately modifying the material. Many types of large machinery and hand tools are used showing a range of practical skills.	This part of the specification is fulfilled. A large range of equipment was used, from hand tools to CNC routers, showing diversity in processes and skills.
2	By reviewing when certain parts of the product were made, and how it would affect assembly if they were made in a different order, I was able to determine if the components had been assembled in a logical order.	By making the metal components first, then making the box, I feel that I fulfilled this specification. Once making the metal parts, I was able to measure their sizes to see if they were in line with the instructions. If they weren't, any modifications could easily be made to the box. If the box had been made first with the holes drilled, but the metal parts to long, they would not fit and new holes would have to be drilled making the box look messy.
3	By reviewing the processes used and comparing them to batch production processes, I was able to determine what would be suitable and what wouldn't be for batch production.	The majority of processes used could easily be automated to allow for batch production. A CNC router is already used to cut parts of the wood for assembly, and a CNC lathe could replace the processes carried out on the workshop lathe. However, cutting space for and screwing the hinges into place would require manual labour, as well as gluing the box together. The steel bars could be brought from a supplier already bent at 90 degrees. This part of the specification is mostly fulfilled, but some components do not fulfil it.
4	By checking that all surfaces are smooth, the hinges move easily, the handle does not move, etc, I am able to determine if the box fulfils this part of the specification.	The quality of varnishing is high and this is good as it is what people notice first. The handle feels secure and firm, when you carry the box you don't feel like it will suddenly fall from the handle. However, upon closer inspection it is apparent that the box is slightly lop-sided. This is due to the hinges being slightly misplaced. To overcome this I sanded the sides of the box, however it still shows at the back. There are also holes that are filled with filler which shows the box was rushed towards the end. At first glance the box is of high quality, but a closer look shows it has flaws which could have been addressed. Overall this box is of medium quality, not fulfilling the specification.
5	By comparing the materials chosen with other possible materials.	In total there were 3 different materials used (excluding hinges). I consider this a range of materials, as the end product was a box which could have easily been made from 1 material. The rubber wood makes a suitable material as it is available in large boards, not planks, which means there was less limitation on size. It is also cheap and durable, with a reasonable aesthetic look once varnished. The aluminium screws, catches and handle were easy to cut and file which sped up the process. The steel bars connecting the handle to the box are strong and once chromed give a very aesthetic finish. It fulfils this part of the specification
6	By placing paper into the box and taking it out again, I can test to see if the box meets this part of the specification.	The paper fit in the box very well, leaving a slight gap around the edge. But other problems arose when more than 1 sheet of paper was used. Getting paper out was hard as different sheets took up all the space round the edges. Also, when carrying the box with paper in, the two bolts caused the paper to crease and could potentially damage it. I feel it does not fulfil this part of the specification.
7	By opening the box and carrying it around, I can see how secure the box is.	As all the sides of the box are mostly flush, it can be hard to open the box as there is nothing to grip onto. Other than that the hinges move easily and the box does not open while being carried or shaken.



The paper fits squarely in the box, meaning that the box has been made to the correct dimensions.



There is just enough space to fit your hands in to access the paper. This is a problem with more sheets as they take up a lot more space and are harder to reach.



A main concern is the bolts. During transport, paper can become creased as they get caught between the bolts. More paper makes this a larger problem as they push the top pieces of paper into the bolts, damaging the paper.



The catches face downwards when being carried. This is because gravity will keep them in place even if the box is being shaken. If they faced the other way around, they are likely to come loose when shaken.



The main let down in quality is the top not being in line with the bottom. On the left you can see the edge is not seen, but on the right it is.

3rd Party Testing

I asked a few people to test the box. This involved them carrying, opening, putting paper in and taking it out again. They then gave me feedback and I have compiled their comments in boxes below.

Carrying

The overall response was that the box is heavy. They didn't like the idea of something designed to carry paper being so heavy. Some went on to say that other products designed to carry paper are very slim and weigh little compared to this box. Other comments were that it was wide and it kept hitting the side of the carrier's leg which became painful after a while due to the corners.

These comments show that the box was made from materials that are too heavy when considering similar products do the job and weigh a fraction of this box. One person pointed out that the idea of a "box" for carrying paper is odd, and should be marketed as a box for carrying something more suitable. As for rubbing/hitting the side of the legs, there is not much that could be done to change this. The location of the handle could be moved slightly more to one side but this would make it awkward to carry if the box was heavily weighted.

Some users said that they didn't like putting the box down from carrying, as it would rest the box on the hinges and cause it to lean to one side. At first this made some users worry that it was about to fall over. Rubber feet could fix this problem easily. The handle was nice to hold and they liked the look of the knurling on the handle and bolts.



Rubs against legs

Putting paper in and removing it

All the users easily managed to put the paper into the box, saying the paper easily slid right in. However, many encountered problems when trying to remove paper. There were lots of comments about the difficulty of removing paper. It seemed as the more pieces of paper inside; the harder it was to remove all the pieces at once. Many had to remove the paper in piles instead of all at once. People with particularly large hands complained the most as they had lots of trouble getting fingers under the paper between the wood.

Another problem with removing the paper is that the bolts got in the way of the paper, often creasing and in a few cases tearing the paper. This was seen by some as a "large design flaw" and if made again should be designed differently. I also encountered this problem on the previous testing page and it could be fixed by counter sinking the bolts into the wood, leaving a flush finish behind.

Something else mentioned was that the inner edge of the box seemed sharp. On one person it seemed to scrape the skin slightly. This could be fixed by some sanding, giving the wood a chamfer or taper edge.



Some users struggled to open the box as the varnish was not easy to grip.



The main complaint of the box was finding it hard to remove paper due to the lack of space between the box and paper

Some said the inner edges of the wood were too sharp

Opening
Most users managed to open the box without needing any instructions. One needed help as they didn't know which way the catches opened and started to loosen the bolts instead. Overall there were no complaints about this method of closing and opening. It was seen as a smart method of keeping the box shut. I was asked if a bolt on each side was really necessary, as it just made the task of opening twice as long. This may be something to look into if the box is made again.