

DESIGN AND TECHNOLOGY

9705/32

Paper 3

October/November 2018

3 hours

Additional Materials: Answer Booklet/Paper
 A range of design drawing equipment
 A3 Drawing Paper (5 sheets)



READ THESE INSTRUCTIONS FIRST

Write your Centre number, candidate number and name on all the work you hand in.
Write in dark blue or black pen.
You may use an HB pencil for any diagrams, graphs or rough working.
Do not use staples, paper clips, glue or correction fluid.
DO NOT WRITE IN ANY BARCODES.

Section A

Answer **two** questions from **one** of the Parts **A**, **B** or **C**.

Section B

Answer **one** question.

All dimensions are in millimetres.

The instruction 'discuss' denotes that you should:

- examine critically the issues raised by the question;
- explain and interpret these issues as appropriate;
- introduce evidence wherever possible to support conclusions of arguments.

At the end of the examination, fasten all your work securely together.

The number of marks is given in brackets [] at the end of each question or part question.

This document consists of **10** printed pages and **2** blank pages.

Section A

Answer **two** questions from **one** of the Parts **A**, **B** or **C**.

Part A – Product Design

1

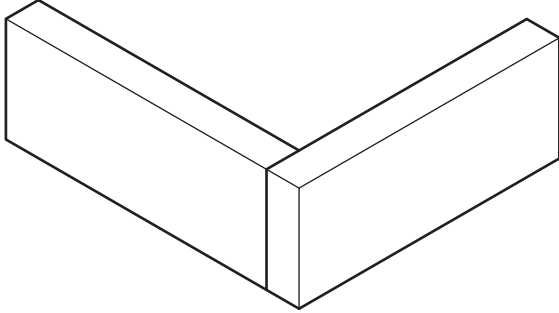

item: frame construction
process: dowel joint

item: lid and handle
process: riveting

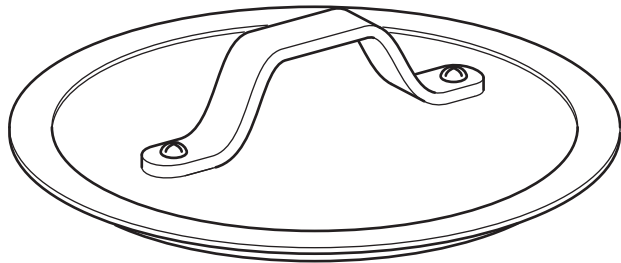

item: face mask
process: vacuum forming

Fig. 1

Choose **two** of the items shown in Fig. 1 **and** for each:

- (a) use notes and sketches to describe how the process has been used in the manufacture of the item; [14]
- (b) explain why the process is particularly suitable in the production of the item. [6]

- 2 Fig. 2 shows a docking station for a mobile phone.

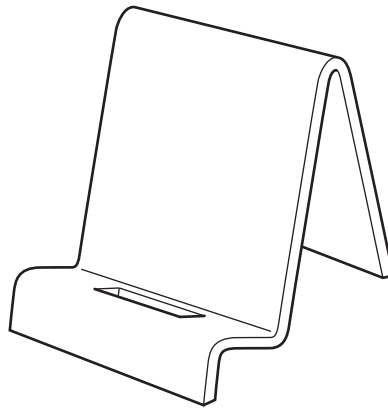

Fig. 2

- (a) State a suitable material for a docking station of the type shown in Fig. 2 **and** give **two** reasons for your choice. [3]
- (b) Describe, using notes and sketches, how you would make the docking station. [9]
- (c) Explain the changes which may be necessary to the design, the manufacturing method used and the material selected, if 50 identical docking stations were required. Use notes and sketches to support your answer. [8]
- 3 For a product to be successful, it must satisfy the needs of customers and users. Discuss how designers consider the physical and aesthetic needs of customers and users. [20]

Part B – Practical Technology

4 Fig. 3 shows an incomplete circuit.

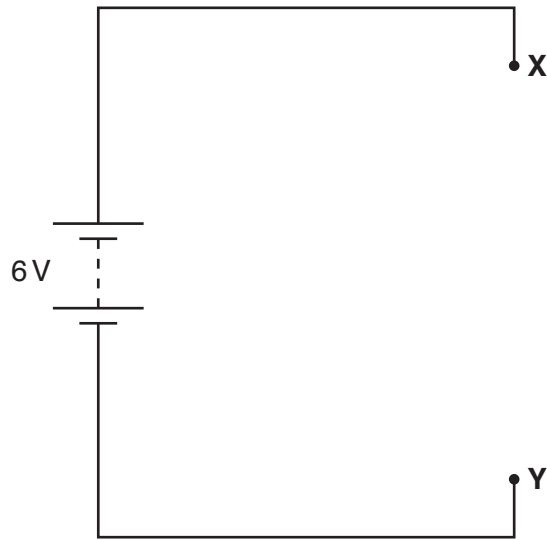

Fig. 3

(a) The following three resistors are to be included in the circuit between points X and Y.

50 Ω
 250 Ω
 1 k Ω

- (i) Complete the circuit with the 250 Ω and 1 k Ω resistors connected in parallel and the 50 Ω in series with them. [2]
- (ii) Calculate the value for one resistor that could be used to replace the three used in the circuit. [4]
- (iii) Calculate the total current flowing in the circuit. [4]

(b) Fig. 4 shows the symbol for a logic gate.

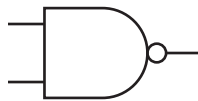

Fig. 4

- (i) Give the name of the logic gate shown. [1]
- (ii) Draw the truth table for the logic gate. [2]
- (iii) Explain what is meant by a flip-flop in a logic circuit. [3]
- (iv) Draw a logic circuit to show how it is possible to cross couple gates to produce a flip-flop. [4]

5 (a) Use notes and sketches to describe what is meant by:

- a monocoque structure;
- a frame structure.

Give a specific example of each to support your answer.

[6]

(b) Structures are designed to withstand different forces and loads but sometimes fail.

Use examples to describe:

- twisting;
- buckling;
- fatigue.

Use notes and sketches where appropriate to support your answer.

[9]

(c) Fig. 5 shows a diagram of a bridge weighing 120 kN with a truck weighing 10 kN in the position shown.

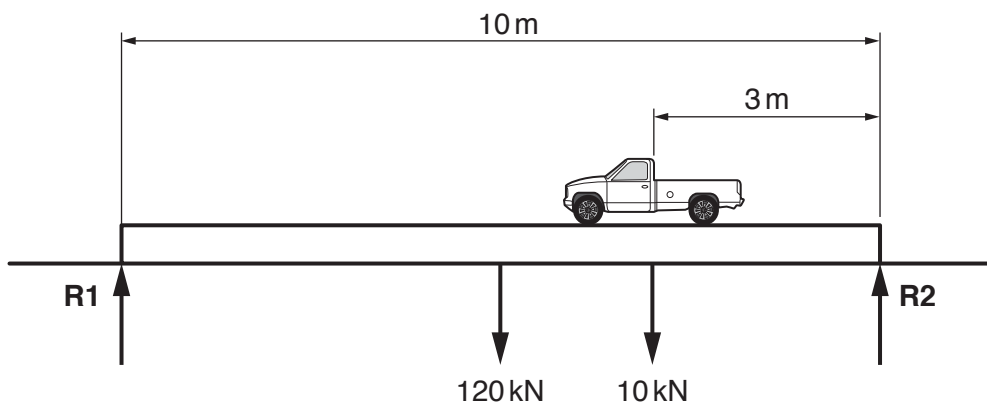

Fig. 5

Calculate the reactions at **R1** and **R2**.

[5]

6 (a) Recent advances in technology have had a major impact upon the design and manufacture of products.

Select a product that has been manufactured using a modern production process. Explain the impact of the process on the success of the product.

[10]

(b) Explain the importance of non-destructive testing in the development of new products. [10]

Part C – Graphic Products

- 7 Fig. 6 shows a design for a card model of a litter bin in the shape of a referee's whistle to be used at a sports event.

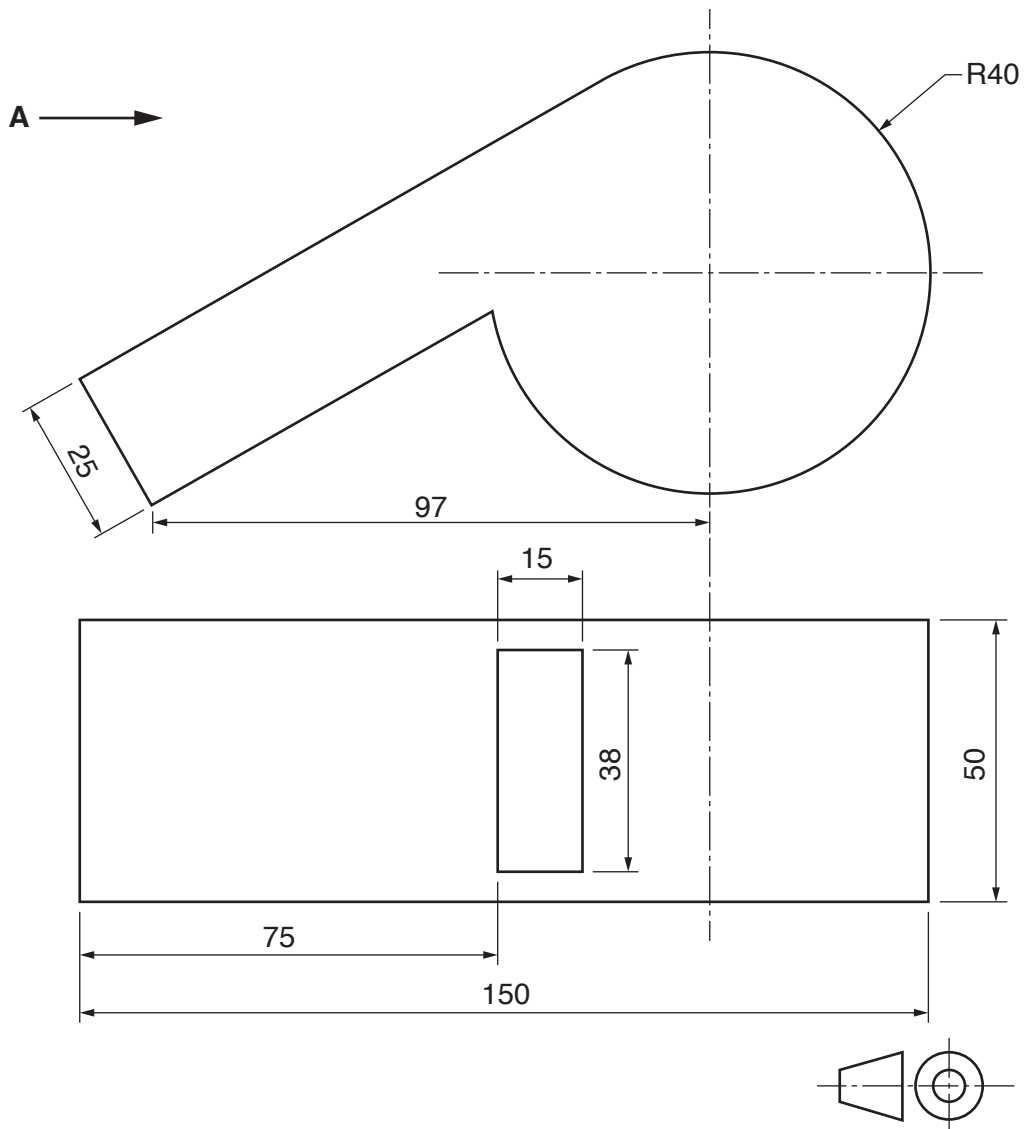

Fig. 6

- (a) Draw, to a scale of 1:10, the given front elevation and plan, and draw an end elevation viewed from the direction of arrow **A**. [10]
- (b) Construct a development (net) of the litter bin. Include glue tabs. [10]

8 Computers play an increasingly important role in the graphics industry.

Discuss the impact of computers in the graphics industry with reference to:

- CAD;
- costing;
- stock control.

[20]

9 Fig. 7 shows a mechanism used in weaving fabrics.

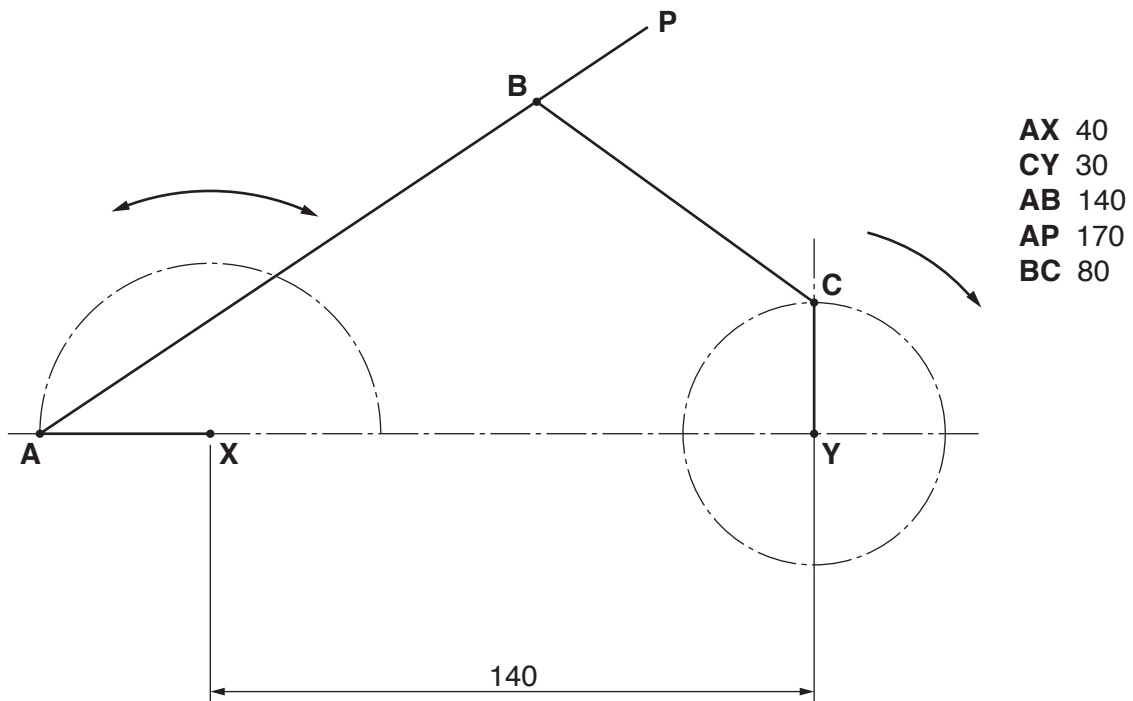

Fig. 7

Link **CY** rotates clockwise about point **Y**.

While link **CY** makes one full rotation, link **AX** rotates clockwise about point **X** for 180° then rotates anti-clockwise to return to its starting position.

A, **B** and **C** are pin joints.

Plot the locus of point **P** for one full rotation of **CY**.

[20]

Section B

Answer **one** question on the A3 paper provided.

You should approach the design question of your choice in the following manner:

Analysis

Produce an analysis of the given situation/problem, which may be in written or graphical form. [5]

Specification

From the analysis produce a detailed written specification of the design requirements. Include at least five specification points other than those given in the question. [5]

Exploration

Use bold sketches and brief notes to show your exploration of ideas for a design solution, with reasons for selection. [25]

Development

Show using bold sketches and notes, the development, reasoning and composition of ideas into a single design proposal. Give details of materials, constructional and other relevant technical details. [25]

Proposed solution

Produce drawings of an appropriate kind to show the complete solution. [15]

Evaluation

Give a written evaluation of the final design solution. [5]

Total: [80]

- 10** Builders, plumbers and joiners often work on sites some distance away from where they park their vehicles. They need to transport tools and equipment to their workplace and often require a device to hold materials when cutting and drilling.

Design a dual-purpose product that can transport tools and equipment from a vehicle to the workplace, and that can also hold materials when cutting or drilling.

The product must:

- fold for ease of storage in a vehicle;
- securely transport tools and equipment.

- 11** A nursery school for children aged 3-5 years has classrooms that become very hot during certain times of the year.

Design a portable innovative product that will help to maintain a more comfortable temperature in a classroom.

The product must:

- be freestanding;
- present no risk to children.

Question 12 begins on the next page.

- 12 A company is to launch a science fiction action game called **Out of this World** aimed at 7 to 12 year old children.

The game will be available in DVD format.

Design a freestanding point of sales display for the new game.

The display must:

- securely hold two DVDs;
- include an interactive feature to attract attention.

The size of DVD packaging is shown in Fig. 8.

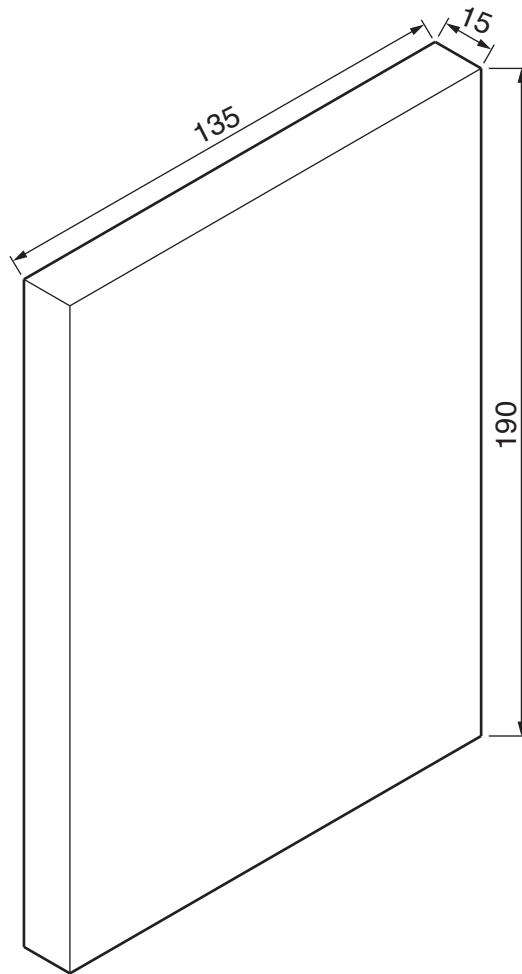

Fig. 8

BLANK PAGE

Permission to reproduce items where third-party owned material protected by copyright is included has been sought and cleared where possible. Every reasonable effort has been made by the publisher (UCLES) to trace copyright holders, but if any items requiring clearance have unwittingly been included, the publisher will be pleased to make amends at the earliest possible opportunity.

To avoid the issue of disclosure of answer-related information to candidates, all copyright acknowledgements are reproduced online in the Cambridge International Examinations Copyright Acknowledgements Booklet. This is produced for each series of examinations and is freely available to download at www.cie.org.uk after the live examination series.

Cambridge International Examinations is part of the Cambridge Assessment Group. Cambridge Assessment is the brand name of University of Cambridge Local Examinations Syndicate (UCLES), which is itself a department of the University of Cambridge.