

DESIGN AND TECHNOLOGY

9705/12

Paper 1

October/November 2018

3 hours

Additional Materials: Answer Booklet/A4 Paper
 A3 Drawing Paper (2 sheets)
 Extra sheets of A3 drawing paper for candidates who have used up both sides of
 their 2 sheets
 A range of design drawing equipment



READ THESE INSTRUCTIONS FIRST

If you have been given an Answer Booklet, follow the instructions on the front cover of the Booklet.
Write your answers and working on the separate Answer Booklet/Paper provided.
Write your name, Centre number and candidate number on all the work you hand in.
Write in dark blue or black pen.
You may use an HB pencil, or coloured pencils/pens as appropriate, for any diagrams, graphs or rough working.
Do not use staples, paper clips, glue or correction fluid.
DO NOT WRITE IN ANY BARCODES.

Section A
Answer **one** question on the Answer Booklet/A4 Paper provided.

Section B
Answer **one** question on the Answer Booklet/A4 Paper provided.

Section C
Answer **one** question on plain A3 paper.
Use **both** sides of the paper.
You may request additional sheets of A3 paper, but only if you have used up both sides of each of the 2 sheets provided.

You are advised to spend **30 minutes** on each of Sections A and B and **2 hours** on Section C.

At the end of the examination, fasten all your work securely together.
The number of marks is given in brackets [] at the end of each question or part question.
All dimensions are in millimetres.

This document consists of **14** printed pages and **2** blank pages.

Section A

Answer **one** question from this section on the Answer Booklet/A4 paper provided.

- 1 Fig. 1 gives details about the base for a microphone stand, made from steel that is to be produced in a school workshop.

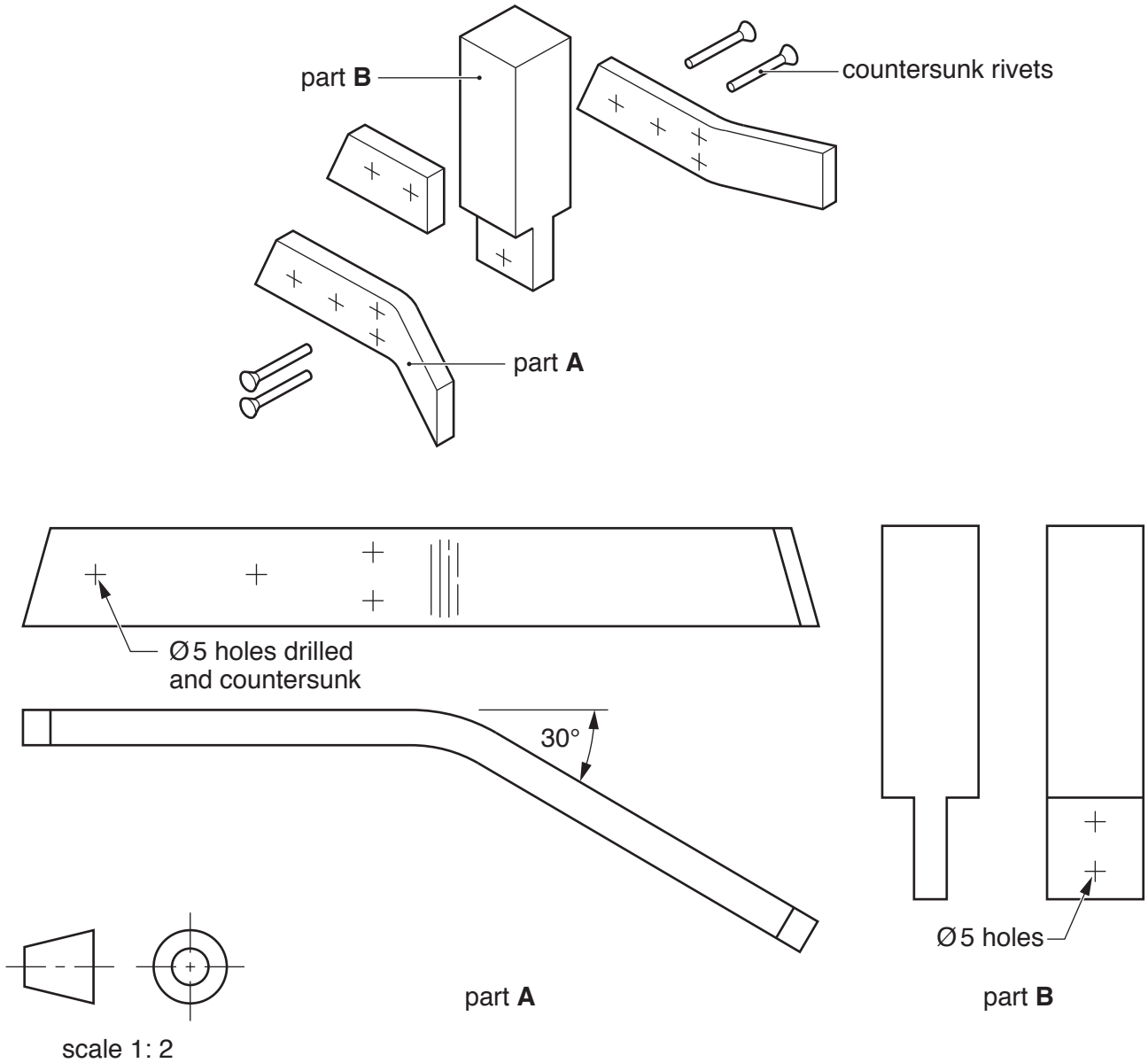

Fig. 1

- (a) Steel is an alloy.
Explain what is meant by an alloy. [2]
- (b) Use notes and sketches to describe:
- (i) how part **A** could be made; [6]
 - (ii) how part **B** could be made; [6]
 - (iii) how the four parts of the base could be riveted together. [6]

You must give details about the tools, equipment and processes involved and the safety precautions that have to be undertaken at each stage.

- 2 Fig. 2 gives details about a mechanical toy that is to be made in a school workshop. As the handle is turned, person **A** moves up and down.

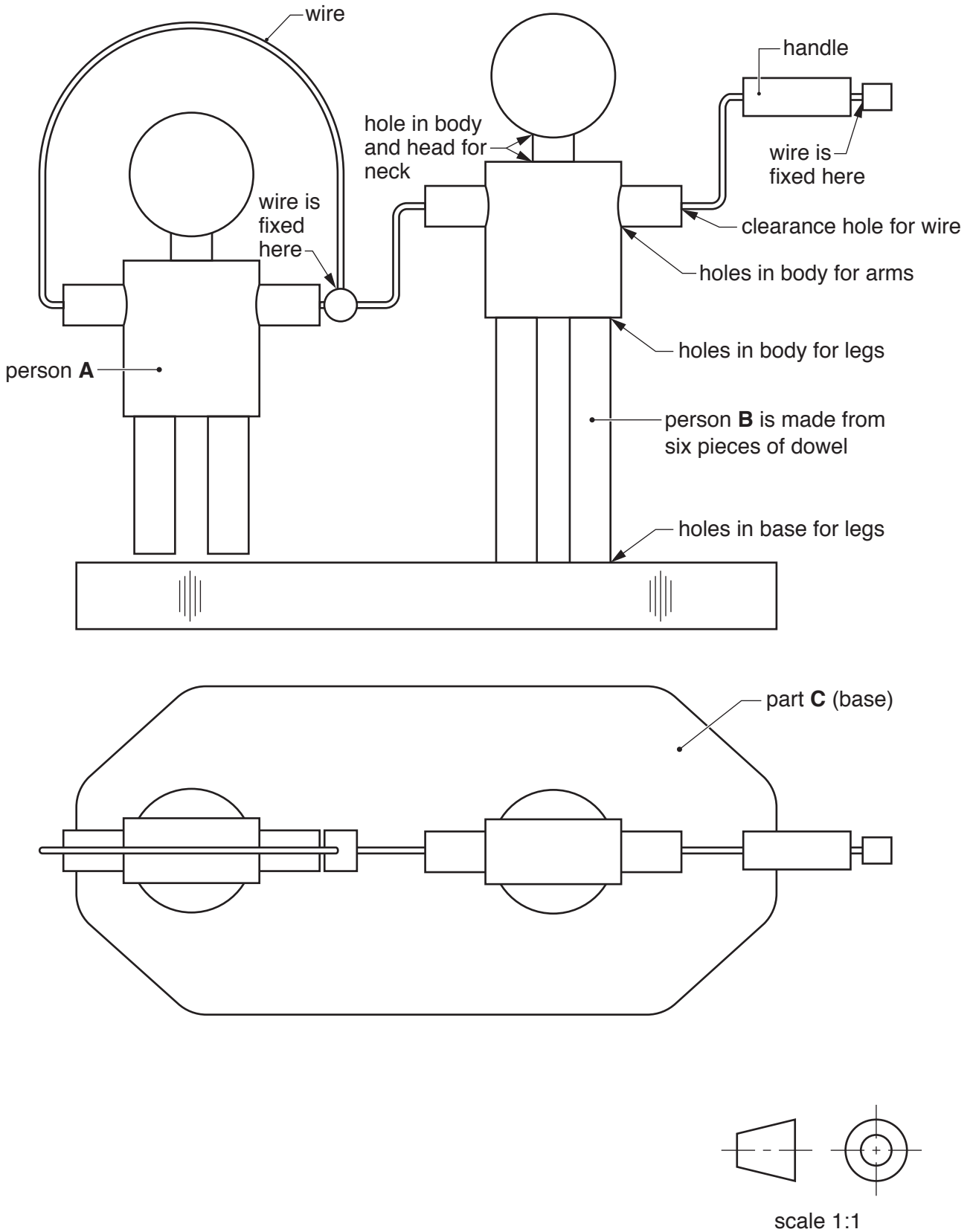

Fig. 2

- (a) Explain why the wire will need to be bent in stages as the toy is assembled. [2]
- (b) Use notes and sketches to describe:
- (i) how person **B** could be made from six pieces of dowel; [6]
 - (ii) how part **C** could be made; [6]
 - (iii) the stages needed to bend the wire to the required shape as the toy is assembled. [6]

You must give details about the tools, equipment and processes involved and the safety precautions that have to be undertaken at each stage.

- 3 Fig. 3 gives details about card models of a dog and its kennel that are to be made in a school workshop.

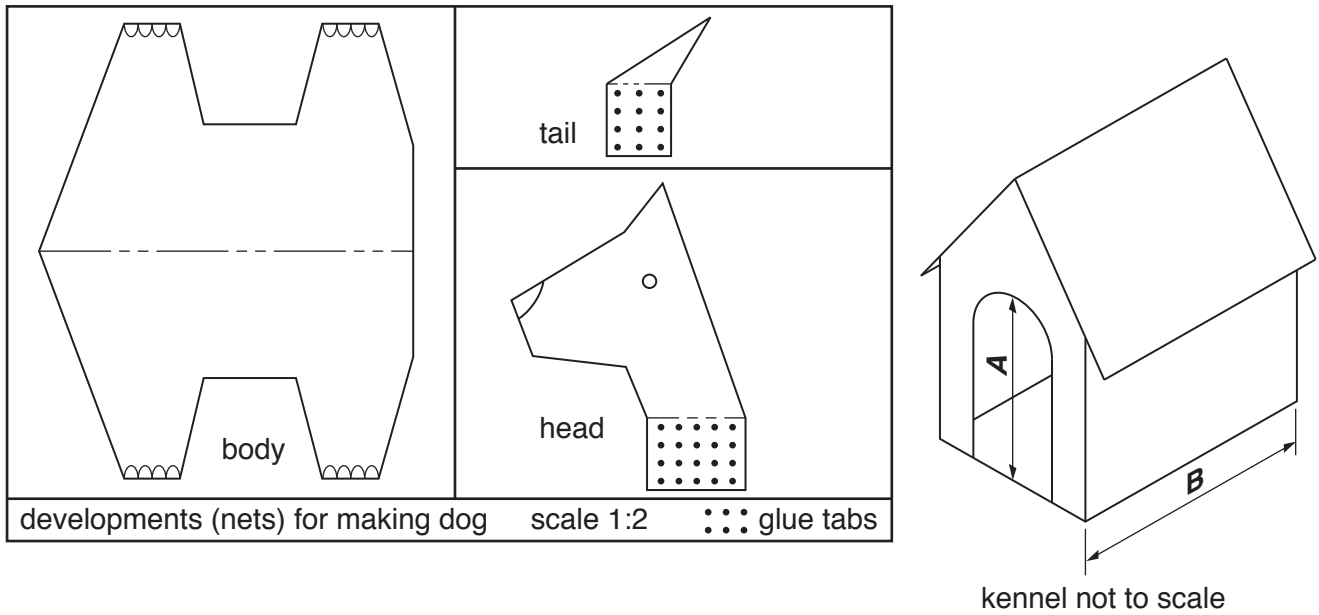

Fig. 3

- (a) State the size that would need to be considered when determining:
- (i) dimension **A**; [1]
 - (ii) dimension **B**. [1]
- (b) Use notes and sketches to:
- (i) describe how the three parts required to make the dog could be cut out and assembled. The glue tabs should not be visible on the outside of the model. [6]
 - (ii) draw and label the two developments (nets) required to make the kennel. [6]
- (c) Using notes and sketches, produce a stage by stage work plan for cutting out and assembling the model of the kennel. [6]

You must give details about the tools, equipment and processes involved and the safety precautions that have to be undertaken at each stage.

Section B

Answer **one** question from this section on the Answer Booklet/A4 paper provided.

- 4 Fig. 4 gives details about a child's chair that is made from five pieces of plywood which slot together. The chair will be manufactured and sold in flat-pack form, ready for the customer to assemble at home.

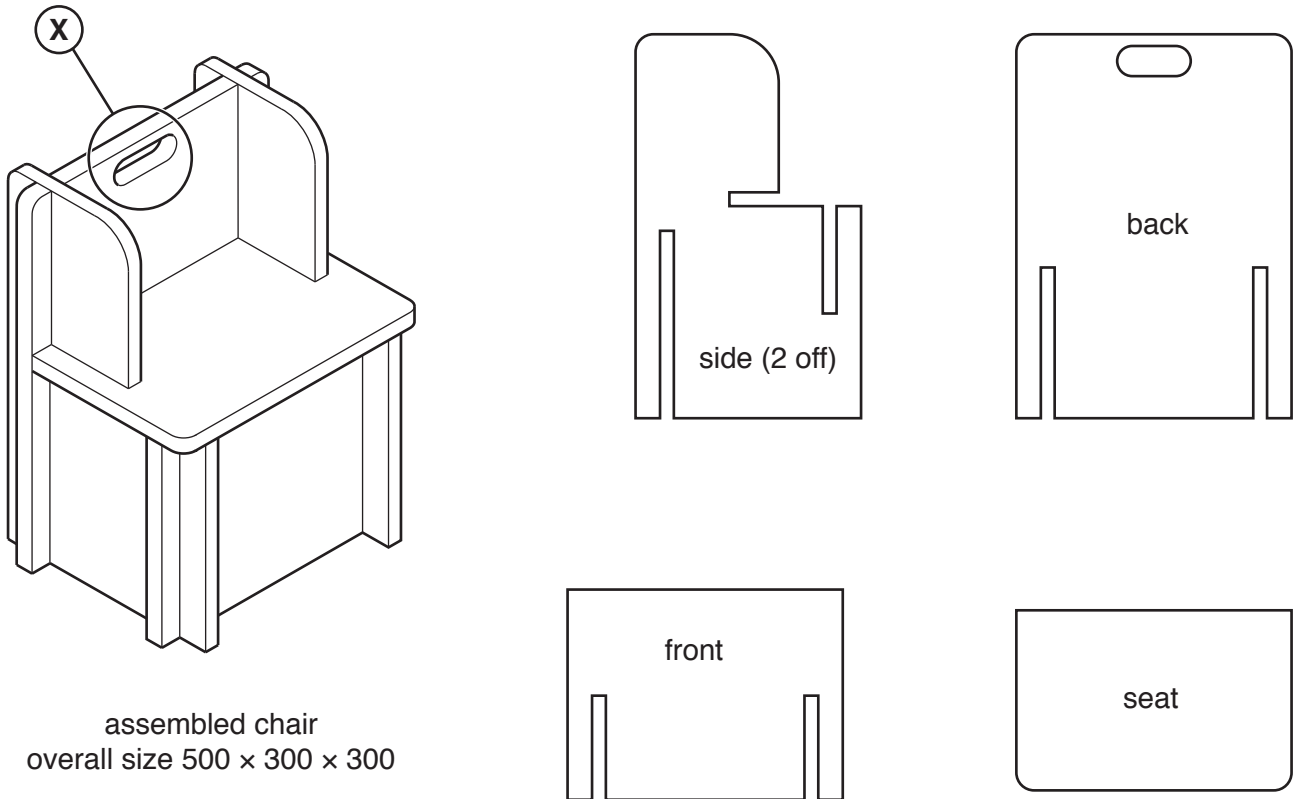

Fig. 4

- (a) Explain the function of the feature shown at X. [2]
- (b) Identify and describe **two** problems with the design of some of the pieces that slot together. [4]
- (c) Using notes and sketches, explain how the designs would need to be changed to overcome the two problems you have identified in **part (b)**. [6]
- (d) Discuss how the manufacturers of flat-pack furniture make their products suitable for home assembly.

Your answer should:

- (i) analyse the given situation and identify **three** relevant issues raised by the question; [3]
- (ii) explain why you consider these issues to be relevant; [3]
- (iii) contain specific examples/evidence to support your conclusions. [2]

- 5 Fig. 5 shows the development (net) of a box made from card. The box has a tuck in top and an automatic base (also known as a crash lock base). The four parts **A**, **B**, **C** and **D** lock together to form the base without the need for gluing.

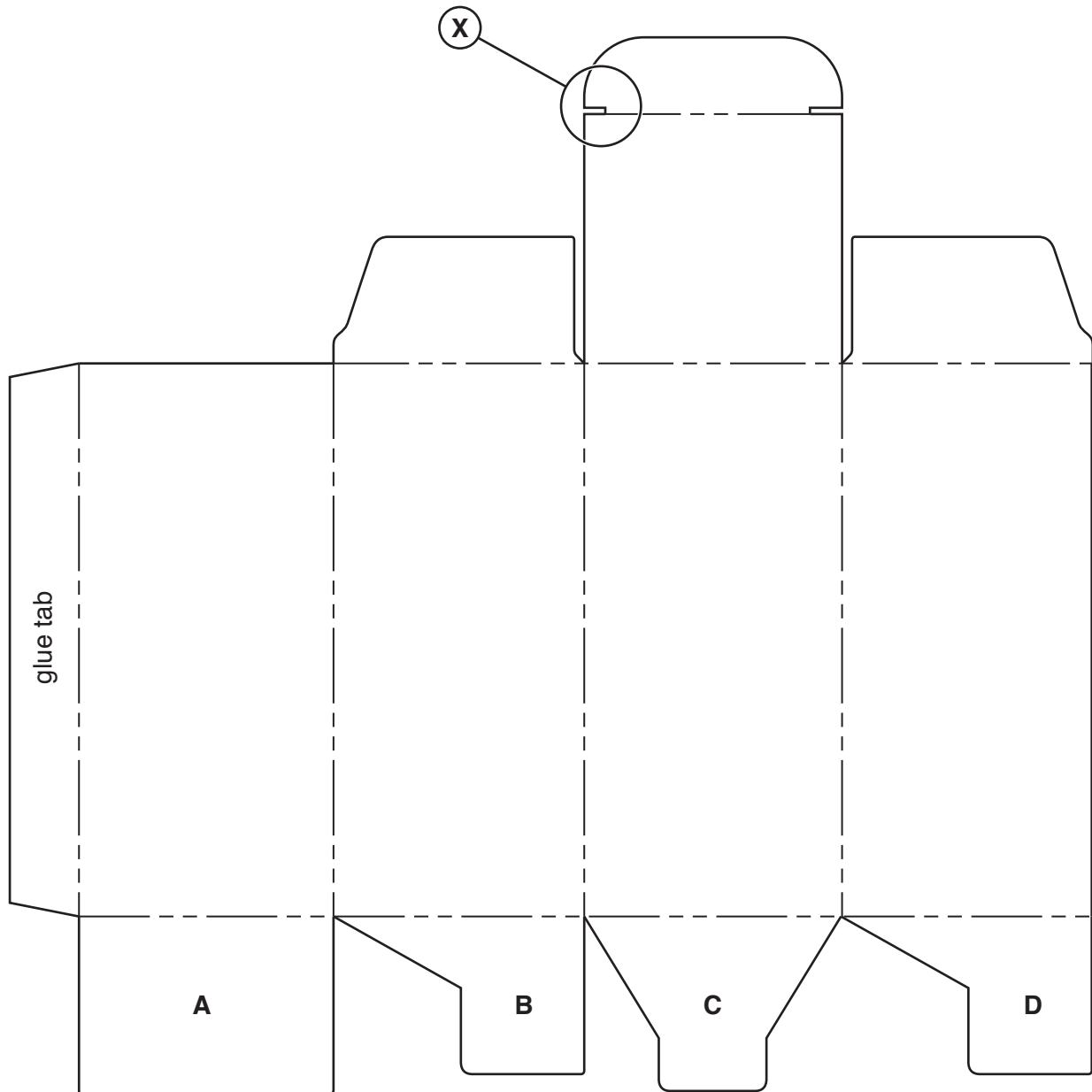

Fig. 5

- (a) Explain the function of the feature shown at **X**. [2]
- (b) Identify and describe **two** problems with the design of the base of the box. [4]
- (c) Using notes and sketches, explain how the design would need to be changed to overcome the two problems you have identified in **part (b)**. [6]

- (d) Discuss how and why companies need to consider the economical use of materials and other resources when designing and manufacturing packaging.

Your answer should:

- (i) analyse the given situation and identify **three** relevant issues raised by the question; [3]
- (ii) explain why you consider these issues to be relevant; [3]
- (iii) contain specific examples/evidence to support your conclusions. [2]

6 Fig. 6 shows a design for an injection moulding machine.

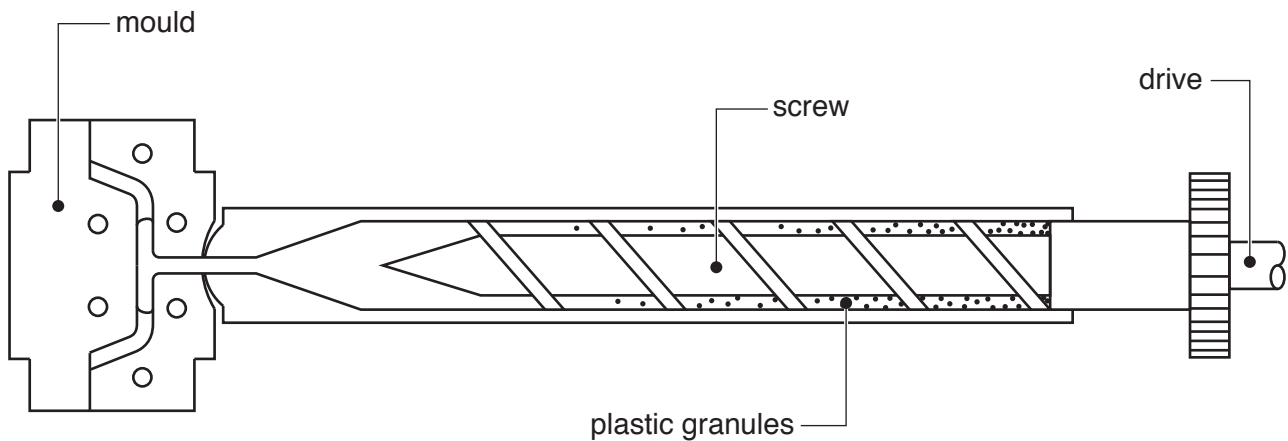

Fig. 6

- (a) Explain the function of the screw. [2]
- (b) Identify and describe **two** problems with the design of the injection moulding machine. [4]
- (c) Using notes and sketches, explain how the design would need to be changed to overcome the two problems you have identified in **part (b)**. [6]
- (d) Discuss the effects that the introduction of high volume mass production processes such as injection moulding has on a company's workforce.

Your answer should:

- (i) analyse the given situation and identify **three** relevant issues raised by the question; [3]
- (ii) explain why you consider these issues to be relevant; [3]
- (iii) contain specific examples/evidence to support your conclusions. [2]

Section C

Answer **one** question from this section on the plain A3 paper provided.

You are provided with two sheets of plain A3 paper. You should use **both** sides of the paper. **Each** of the four **parts (a)–(d)** of the question you choose to answer should take up one side of paper.

When you are asked to **develop** a design you must show, using notes and sketches, the development and evaluation of a **range** of ideas into a single design proposal. The design proposal should be annotated to give details about materials, joining methods and important sizes.

- 7 Fig. 7 shows an incomplete idea for an adjustable table that can be used by one person while seated in any type of chair.

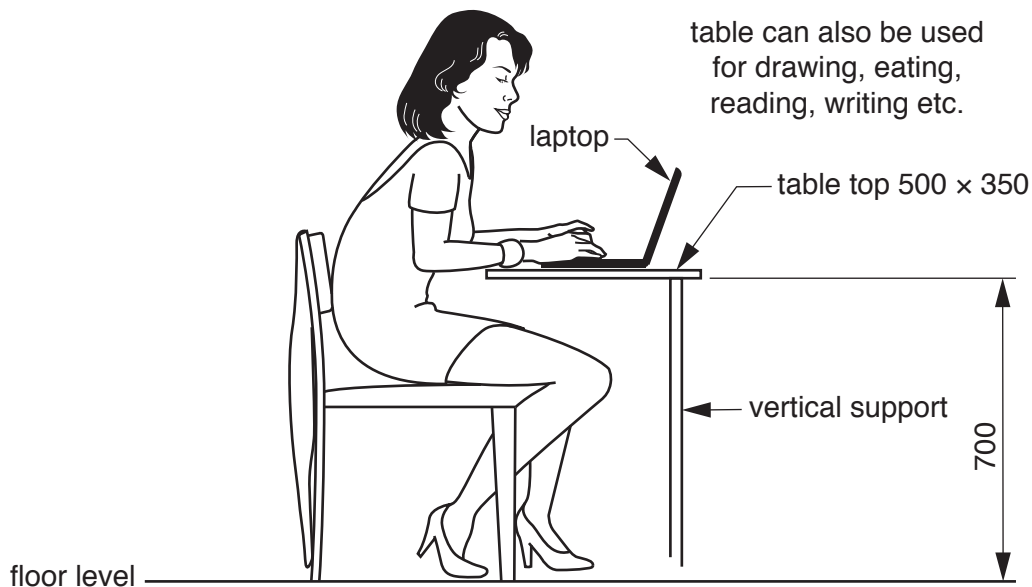

Fig. 7

- (a) Using notes and sketches, **develop** a design for a stable base for the table. This must include a method of joining the base to the vertical support. [20]
- (b) Using notes and sketches, **develop** a design which allows the vertical support to be adjusted and fixed at different heights. [20]
- (c) Using notes and sketches, **develop** a design for the top of the table which includes:
- (i) a method of joining the top to the vertical support;
 - (ii) a feature which allows the top to be adjusted and fixed at different angles. [20]
- (d) Produce a pictorial rendered drawing of the complete table which shows all of the features that you have designed in **parts (a)–(c)**. [20]

8 Fig. 8 shows an incomplete idea for packing a ring.

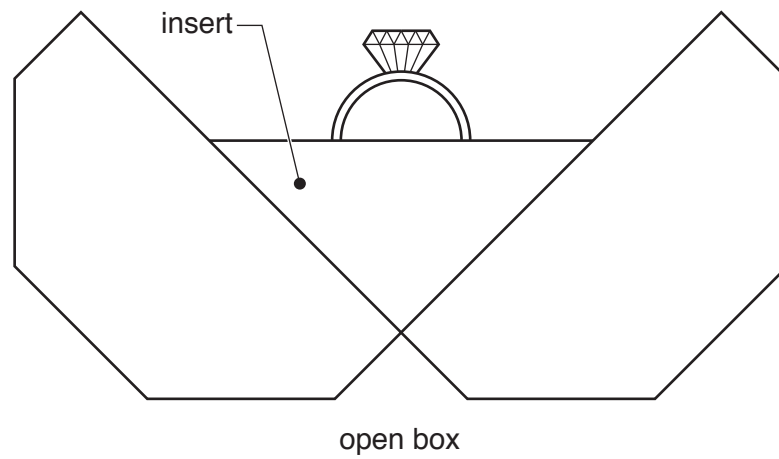
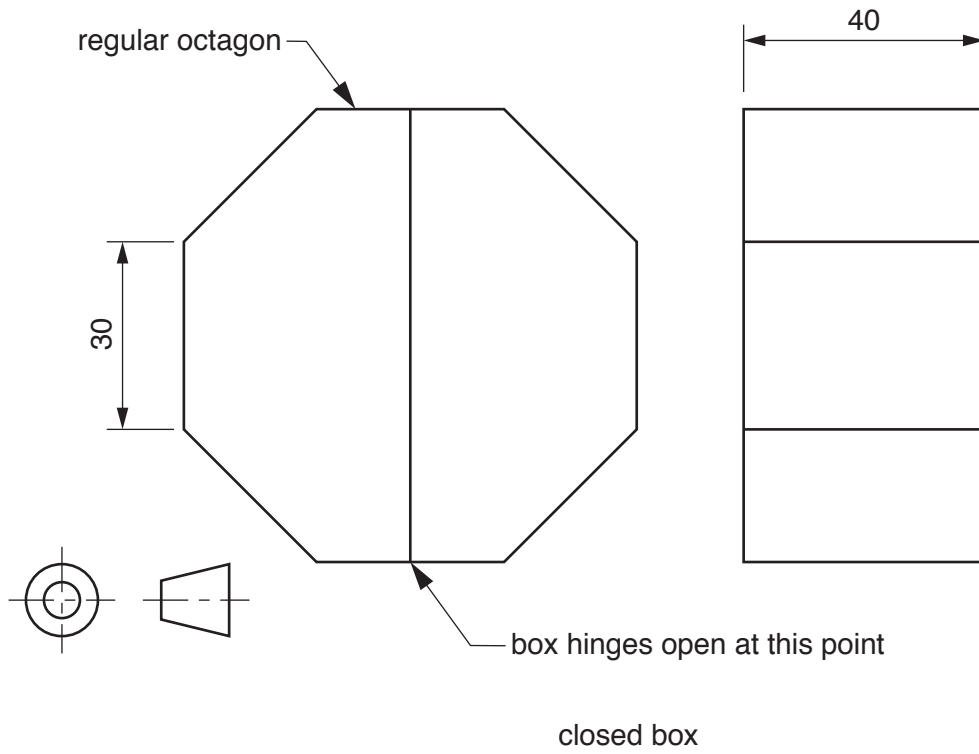

Fig. 8

- (a) Using notes and sketches, **develop** a design for the card box. Your design work must include details of the one piece development (net) required to make the box. [20]
- (b) Using notes and sketches, **develop** a design for an insert to go in the box to hold the ring securely in the position shown. [20]
- (c) Using notes and sketches, **develop** a design for the lettering to go on the packaging. The company's name is '**Rings and Things**' and the lettering should be in a style that reflects the product being packaged. [20]
- (d) Produce a pictorial rendered drawing of the complete packaging that shows all of the features that you have designed in **parts (a)–(c)**.
The packaging should be shown open.
Do **not** include the ring in this drawing. [20]

- 9 Fig. 9 shows an incomplete design for modular garden furniture that combines a seat, with storage space underneath, three plant containers and supports for plants to climb up.

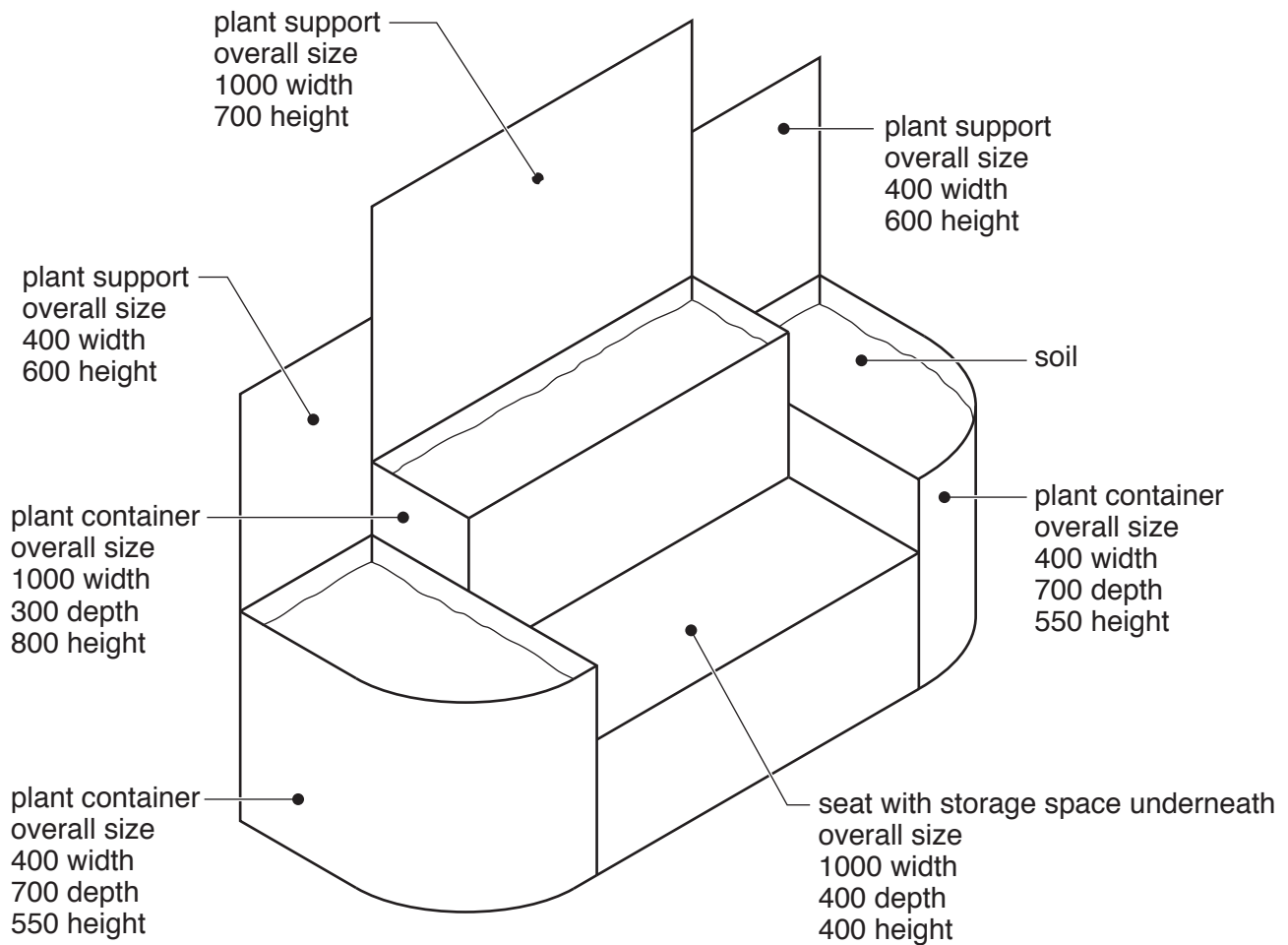

Fig. 9

- (a) Using notes and sketches, **develop** a design for the seat with storage space underneath. [20]
- (b) Using notes and sketches, **develop** designs for the three plant containers. [20]
- (c) Using notes and sketches, **develop** designs for the three plant supports. [20]
- (d) Produce a pictorial rendered drawing of the modular garden furniture that shows all of the features that you have designed in **parts (a)–(c)**. [20]

BLANK PAGE

Permission to reproduce items where third-party owned material protected by copyright is included has been sought and cleared where possible. Every reasonable effort has been made by the publisher (UCLES) to trace copyright holders, but if any items requiring clearance have unwittingly been included, the publisher will be pleased to make amends at the earliest possible opportunity.

To avoid the issue of disclosure of answer-related information to candidates, all copyright acknowledgements are reproduced online in the Cambridge International Examinations Copyright Acknowledgements Booklet. This is produced for each series of examinations and is freely available to download at www.cie.org.uk after the live examination series.

Cambridge International Examinations is part of the Cambridge Assessment Group. Cambridge Assessment is the brand name of University of Cambridge Local Examinations Syndicate (UCLES), which is itself a department of the University of Cambridge.