



**DESIGN AND TECHNOLOGY**

**9705/33**

Paper 3

**October/November 2010**

**3 hours**

Additional Materials: Answer Booklet/Paper  
A range of design drawing equipment  
A3 Drawing paper (5 sheets)

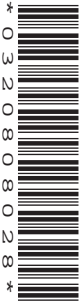

**READ THESE INSTRUCTIONS FIRST**

Write your Centre number, candidate number and name on all the work you hand in.  
Write in dark blue or black pen.  
You may use a soft pencil for any diagrams, graphs or rough working.  
Do not use staples, paper clips, highlighters, glue or correction fluid.

**Section A**

Answer any **two** questions from **one** of the Parts **A**, **B** or **C**.

**Section B**

Answer **one** question.

All dimensions are in millimetres.

The instruction 'discuss' denotes that you should:

- examine critically the issues raised by the question;
- explain and interpret these issues as appropriate;
- introduce evidence wherever possible to support conclusions of arguments.

At the end of the examination, fasten all your work securely together.

The number of marks is given in brackets [ ] at the end of each question or part question.

This document consists of **11** printed pages and **1** blank page.



## Section A

Answer **two** questions from **one** of the Parts **A**, **B** or **C**.

## Part A – Product Design

1

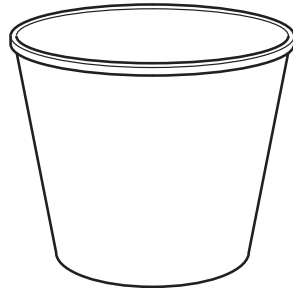

**item:** plastic bucket  
**process:** injection moulding

**item:** hardwood pencil holder  
**process:** turning

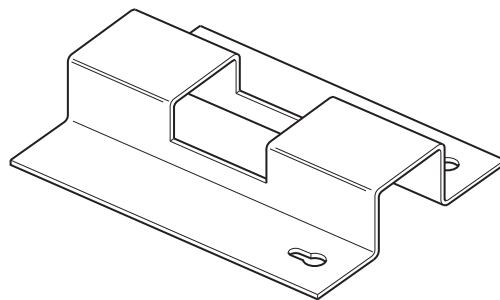
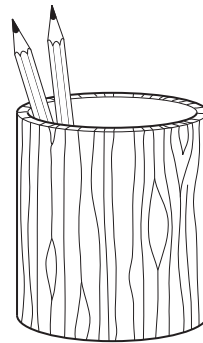

**item:** mild steel wall bracket  
**process:** pressing

Fig. 1

Choose **two** of the items shown in Fig. 1 and for each:

- (a) use notes and sketches to describe the manufacturing process that relates to the chosen item; [7 × 2]
- (b) explain why the process is particularly suitable for the production of the item. [3 × 2]

2 Fig. 2 shows an outline design for a bedside cabinet.

4 mm back to be fitted,  
overall depth of unit  
must not be increased

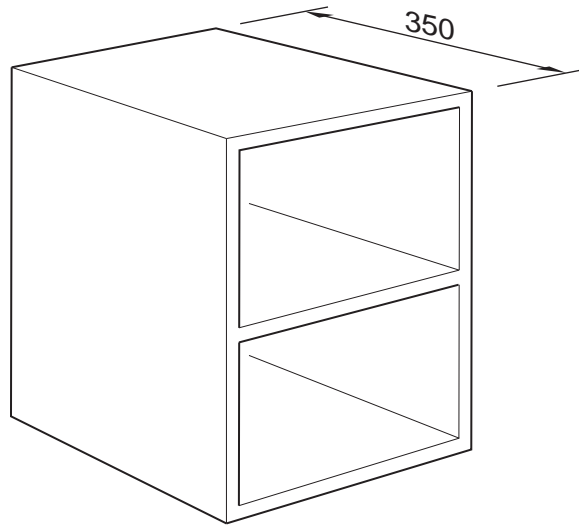

Fig. 2

- (a) State a suitable material for the bedside cabinet and give **two** reasons for your choice. [3]
- (b) Describe, using notes and sketches, how you would make the bedside cabinet. [9]
- (c) Explain what changes may be necessary to the design, in the manufacturing method used and in the material selected if 10 000 cabinets were required. Use notes and sketches to support your answer. [8]
- 3 Use examples to explain in detail how technological developments have improved the design and performance of sports equipment with reference to:
- (a) materials; [10]
- (b) manufacturing technologies. [10]

## Part B – Practical Technology

- 4 Use sketches and notes to describe **four** different mechanisms that will convert **rotary to linear** motion or **linear to rotary** motion.  
For each mechanism, show how it is applied in a product. [4 × 5]

- 5 (a) Calculate the output voltage at **V1** in the arrangement of resistors shown in Fig. 3. [3]

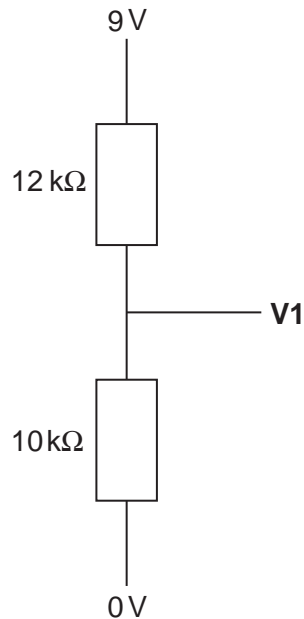

**Fig. 3**

- (b) Use sketches and notes to describe how you would arrange electronic components to construct a basic timer. [5]
- (c) Discuss the implications, for the manufacturer and consumer, of the rapid development of microprocessors and their use in the design of products. [12]

6 (a) Use sketches and notes to describe in detail, how you would join the following:

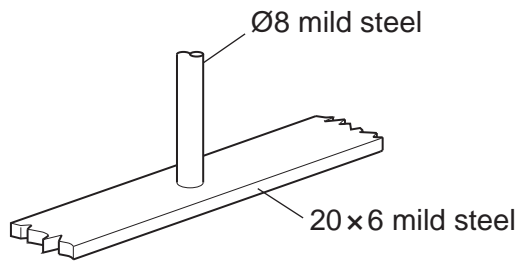

(i) rail to frame of a gate

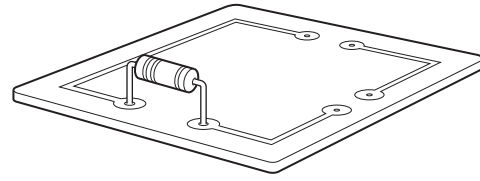

(ii) resistor onto PCB

[12]

(b) Use **two** examples to explain in detail how corrosion can be prevented.

[8]

## Part C – Graphic Products

- 7 Fig. 4 shows the side elevation of a card helmet to be used in a drama production.

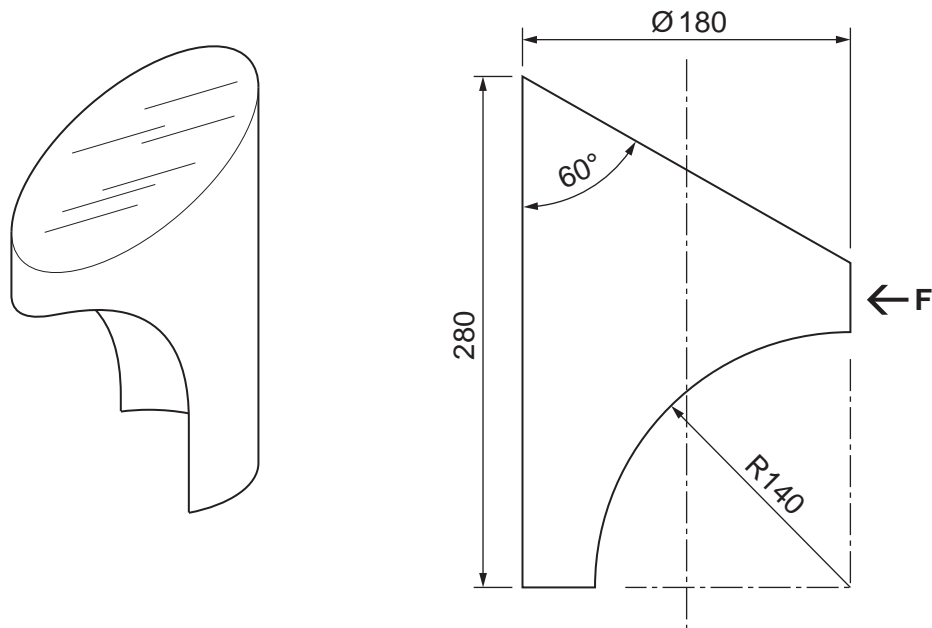
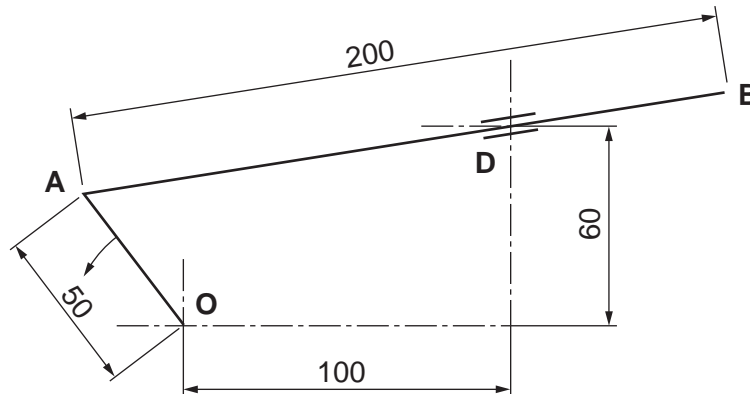

Fig. 4

- (a) Draw, to a scale of 1:2, the side elevation and a front elevation from **F**. [4]
- (b) Construct the developments (nets) to make the helmet. Include details of joining tabs. [10]
- (c) Explain and compare the different methods to apply colour and detail to a batch of 5 helmets and a batch of 5000 helmets. [6]
- 8 Discuss the importance of modelling and testing to architects, product designers and engineers. In your response, compare and contrast between these groups. [20]

- 9 Fig. 5 shows a linkage mechanism.  
 Linkage **OA** rotates about point **O**.  
 Linkage **AB** is connected to **OA** and is free to slide through point **D**, which is free to pivot.



**Fig. 5**

- (a) Draw the locus of point **B** for one full rotation of linkage **OA**. [8]
- (b) Models are helpful in the teaching of mechanisms.  
 Use sketches and notes to describe how you would make a working model of the linkage shown in Fig. 5. [12]

**Section B**

Answer **one** question on the A3 paper provided.

You should approach the design question of your choice in the following manner:

**Analysis**

Produce an analysis of the given situation/problem, which may be in written or graphical form. [5]

**Specification**

From the analysis produce a detailed written specification of the design requirements. Include at least five specification points other than those given in the question. [5]

**Exploration**

Use bold sketches and brief notes to show your exploration of ideas for a design solution, with reasons for selection. [25]

**Development**

Show, using bold sketches and notes, the development, reasoning and composition of ideas into a single design proposal. Give details of materials, constructional and other relevant technical details. [25]

**Proposed solution**

Produce drawings of an appropriate kind to show the complete solution. [15]

**Evaluation**

Give a written evaluation of the final design solution. [5]

[Total: 80]



- 10 A school is to hold an outdoor summer music concert. The audience will be seated in rows. Design a seating unit that will accommodate up to four adults.

The seating unit must be easily stored.

To assist you in your design, details of anthropometric data are given in Fig. 6.

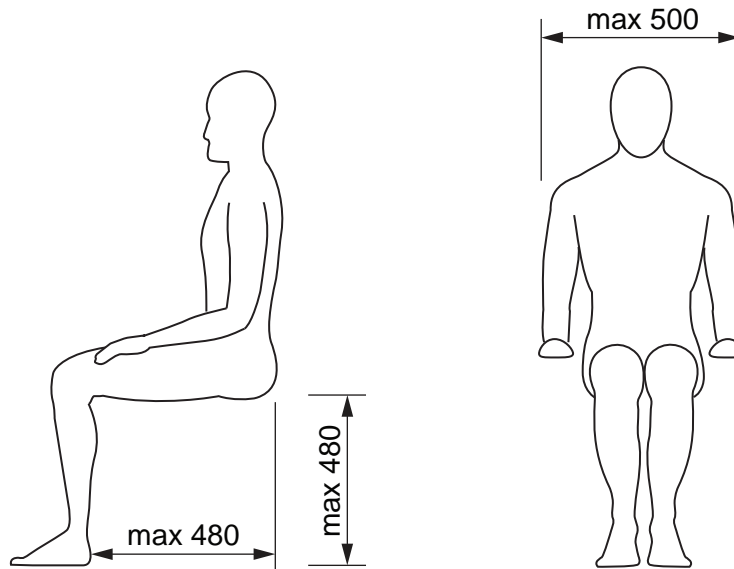

Fig. 6

- 11 A school is to hold an outdoor summer music concert. Some performances will be held in the evening.

Design a stand that will hold sheet music (maximum size A3) for both seated and standing performers.

The stand must include a light to enable the musicians to see their music easily during evening performances.

To assist you in your design anthropometric data is given in Fig. 7.

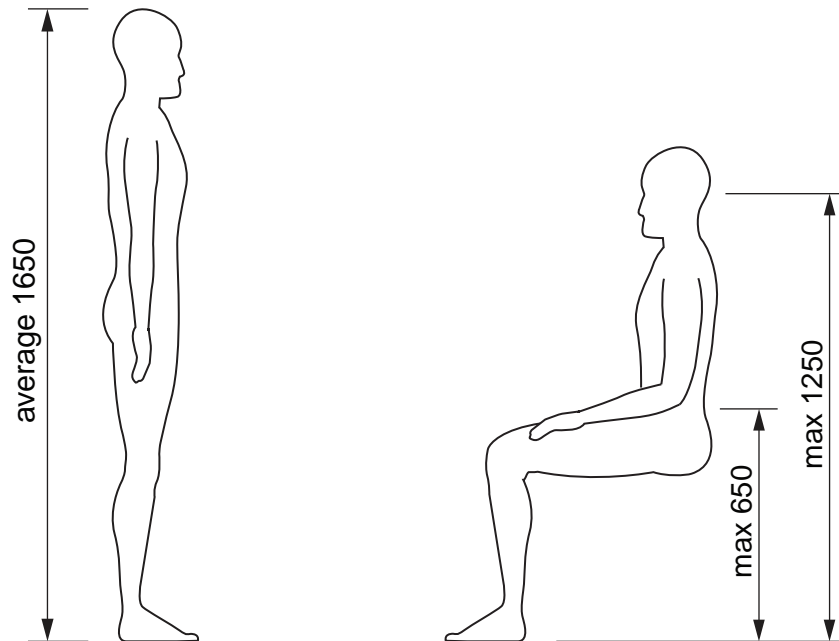

Fig. 7

- 12 A school is to hold an outdoor summer music concert. It requires a raised stage to hold up to 20 musicians/performers.

Design a scale model of a stage set that would be presented to concert organisers as your proposal for the summer music concert stage.

The stage must have a raised area for solo performers.

To assist you in your design, some sizes of the stage are given in Fig. 8.

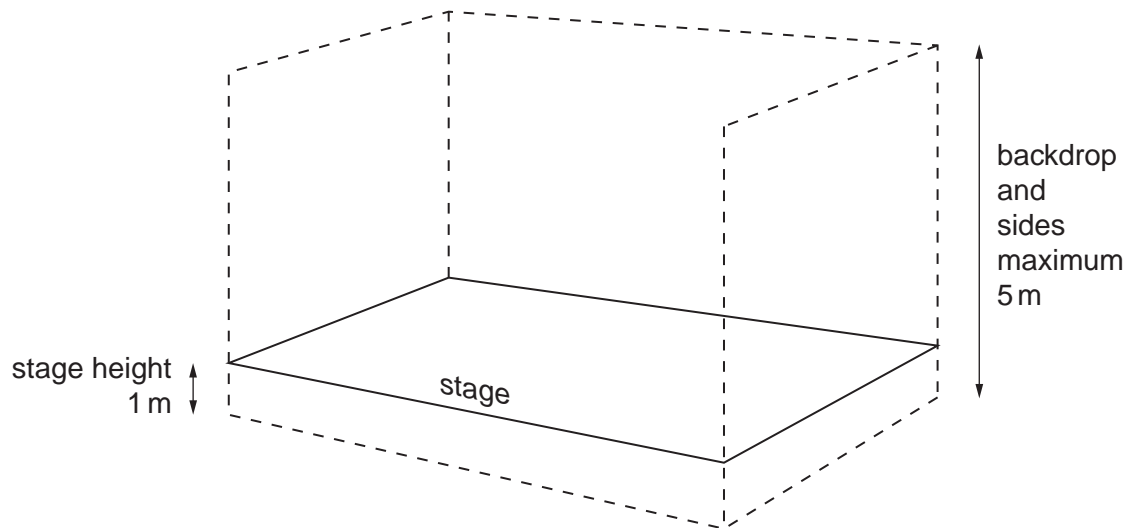

Fig. 8

---

Permission to reproduce items where third-party owned material protected by copyright is included has been sought and cleared where possible. Every reasonable effort has been made by the publisher (UCLES) to trace copyright holders, but if any items requiring clearance have unwittingly been included, the publisher will be pleased to make amends at the earliest possible opportunity.

University of Cambridge International Examinations is part of the Cambridge Assessment Group. Cambridge Assessment is the brand name of University of Cambridge Local Examinations Syndicate (UCLES), which is itself a department of the University of Cambridge.