



DESIGN AND TECHNOLOGY

9705/13

Paper 1

October/November 2010

3 hours

Additional Materials: Answer Booklet/A4 Paper
A3 Drawing paper (3 sheets)
Extra sheets of A3 drawing paper for candidates
who have used both sides of their 3 sheets
A range of design drawing equipment



READ THESE INSTRUCTIONS FIRST

If you have been given an Answer Booklet, follow the instructions on the front cover of the Booklet.
Write your answers and working on the separate Answer Booklet/Paper provided.
Write your name, Centre number and candidate number on all the work you hand in.
Write in dark blue or black pen.
You may use a soft pencil, or coloured pencils/pens as appropriate, for any diagrams, graphs or rough working.
Do not use staples, paper clips, highlighters, glue or correction fluid.
DO NOT WRITE ON ANY BARCODES.

Section A
Answer **one** question on the Answer Booklet/A4 Paper provided.

Section B
Answer **one** question on the Answer Booklet/A4 Paper provided.

Section C
Answer **one** question on plain A3 paper.
Use **both** sides of the paper.
You may request additional sheets of A3 paper, but only if you have used both sides of each of the 3 sheets provided.

You are advised to spend **30 minutes** on each of Sections A and B and **2 hours** on Section C.

At the end of the examination, fasten all your work securely together.
The number of marks is given in brackets [] at the end of each question or part question.
All dimensions are in millimetres.

This document consists of **12** printed pages.



Section A

Answer **one** question from this section on the Answer Booklet/A4 paper provided.

- 1 Fig. 1 shows a balancing toy which is to be made in a school workshop.

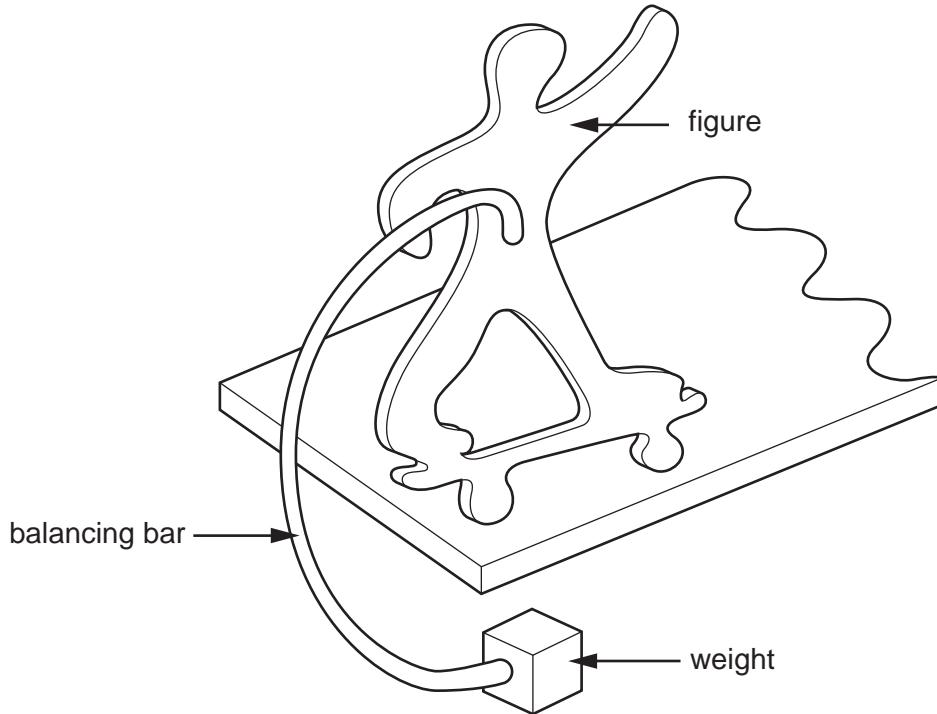

Fig. 1

- (a) Name a suitable sheet material for making the figure and give **one** reason for your choice. [2]
- (b) Use notes and sketches to describe:
- (i) how the figure could be cut out to the required shape and the edges of the sheet material smoothed; [6]
 - (ii) how the balancing bar could be attached to the figure so that it could be easily removed; [6]
 - (iii) how a thread could be made in the weight so that it could be screwed onto the balancing bar. [6]

You must give details about the tools, equipment and processes involved and the safety precautions that have to be undertaken at each stage.

2 Fig. 2 shows a table which is to be made in a school workshop.

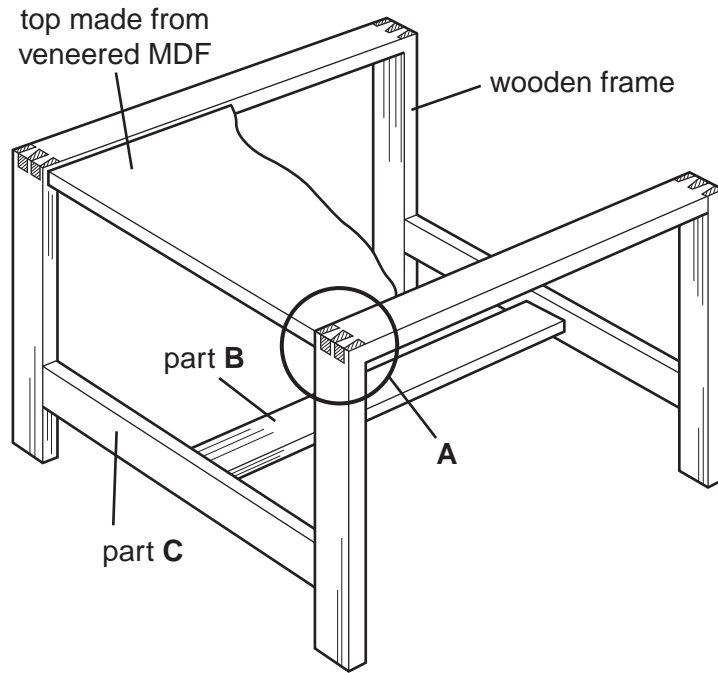

Fig. 2

- (a) The top of the table is made from veneered MDF (medium density fibreboard). Use notes and a sketch to explain what veneered MDF looks like. [2]
- (b) Use sketches and notes to describe:
- (i) how the joint shown at **A** could be made; [6]
 - (ii) how parts **B** and **C** could be joined together. [6]
- (c) Fig. 3 shows a metal plate.

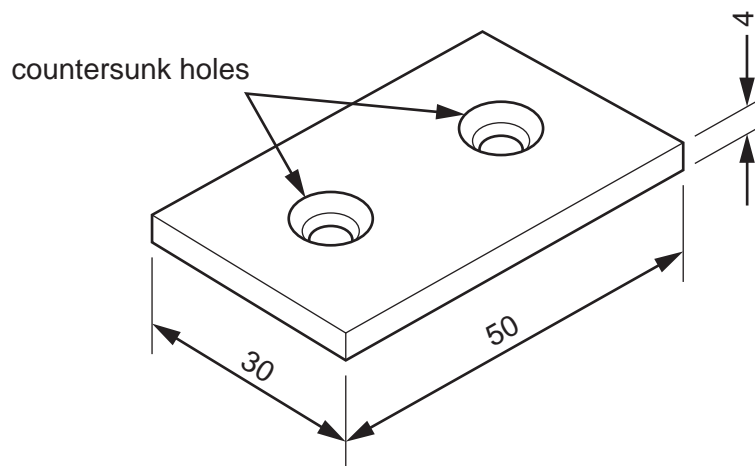

Fig. 3

Use notes and sketches to describe how the metal plate could be made and used to join the frame of the table to the top. [6]

You must give details about the tools, equipment and processes involved and the safety precautions that have to be undertaken at each stage.

3 Fig. 4 shows a card box which is to be made in a school workshop.

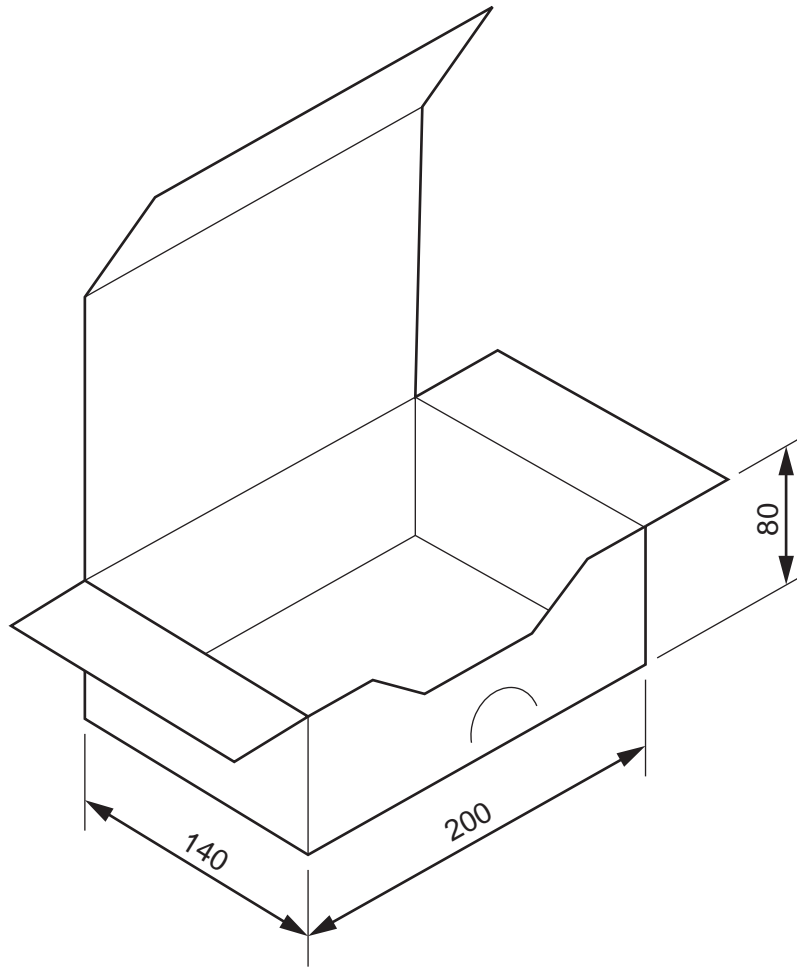

Fig. 4

(a) The box is made from one piece of card with the corners glued together.

Sketch, to an appropriate scale, the development (net) required to make the box. [6]

(b) Fig. 5 shows a plastic insert to hold chocolates. The insert will be made by vacuum forming.

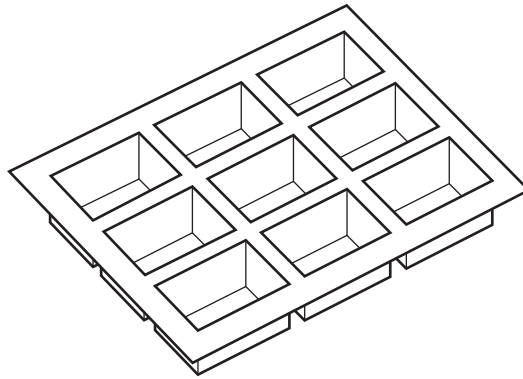

Fig. 5

Three of these inserts will be packaged in the box shown in Fig. 4.

Name a suitable sheet plastic for making the inserts and give **one** reason for your choice. [2]

(c) Use notes and sketches to describe:

(i) how the former required to vacuum form one of the inserts could be made; [6]

(ii) the vacuum forming process. [6]

You must give details about the tools, equipment and processes involved and the safety precautions that have to be undertaken at each stage.

Section B

Answer **one** question from this section on the Answer Booklet/A4 paper provided.

- 4 A band called 'The Ties' is to undertake a tour. Souvenir T-shirts are to be printed and sold at each concert.

A prototype T-shirt is to be printed using a hand-cut stencil. Fig. 6 shows a design for the stencil which will be made from paper.



Fig. 6

- (a) Explain the difference between a stencil and a template. [2]
- (b) Describe **two** problems with the design. [4]
- (c) Using notes and sketches, explain how the design would need to be changed to overcome the two problems that you have identified in (b). [6]
- (d) Discuss the merits of using stencils and templates when batch producing products. Your answer should:
- (i) analyse the given situation and identify three relevant issues raised by the question; [3]
 - (ii) explain why you consider these three issues to be relevant; [3]
 - (iii) contain specific examples/evidence as support for your conclusions. [2]

- 5 Fig. 7 shows a design for a toy rocking horse and a range of symbols that manufacturers put on toys.

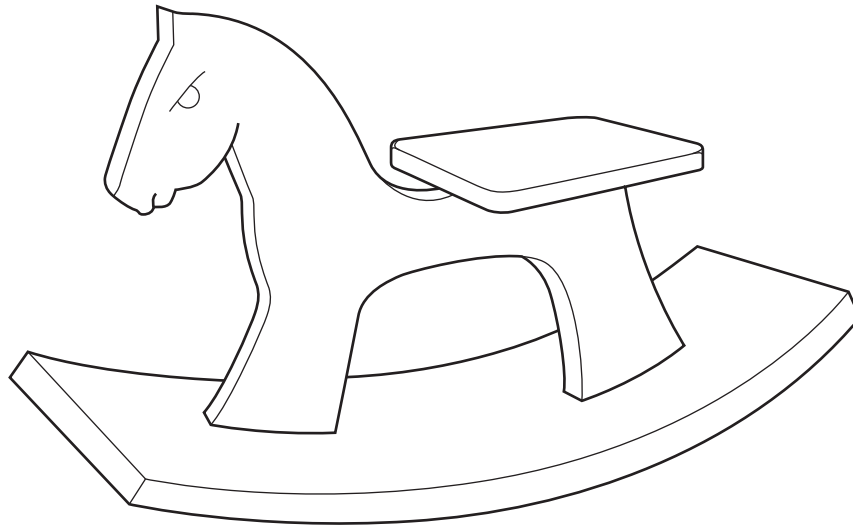

A



B



C



D

Fig. 7

- (a) Select **one** of the symbols and explain what it means. [2]
- (b) Describe **two** problems with the design of the rocking horse. [4]
- (c) Using notes and sketches, explain how the design would need to be changed to overcome the two problems that you have identified in (b). [6]
- (d) Discuss how a designer would need to consider health and safety when designing a child's toy. Your answer should:
- (i) analyse the given situation and identify three relevant issues raised by the question; [3]
 - (ii) explain why you consider these three issues to be relevant; [3]
 - (iii) contain specific examples/evidence as support for your conclusions. [2]

6 Fig. 8 shows a design for a combined table and seat to be used outdoors.

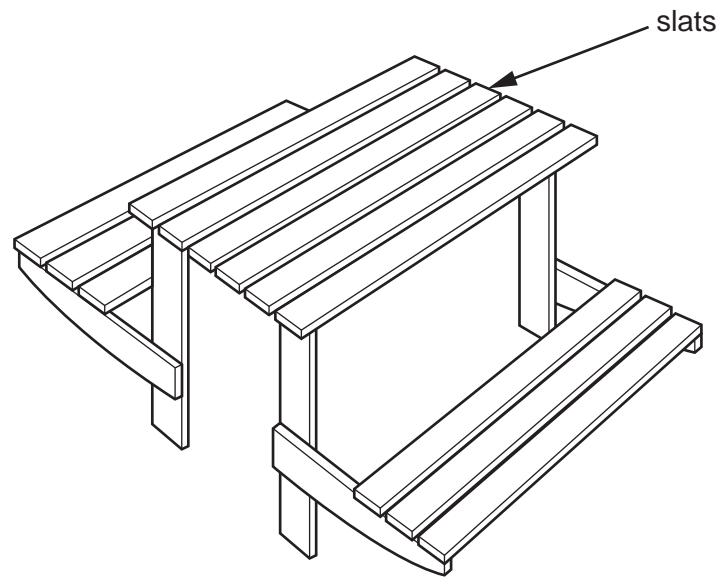

Fig. 8

- (a) Explain why slats are frequently used in the design of outdoor furniture. [2]
- (b) Describe **two** problems with the design. [4]
- (c) Using notes and sketches, explain how the design would need to be changed to overcome the two problems that you have identified in (b). [6]
- (d) Discuss why most outdoor furniture is manufactured and sold in flat pack form rather than ready assembled. Your answer should:
- (i) analyse the given situation and identify three relevant issues raised by the question; [3]
 - (ii) explain why you consider these three issues to be relevant; [3]
 - (iii) contain specific examples/evidence as support for your conclusions. [2]

Section C

Answer **one** question from this section on the plain A3 paper provided.

You are provided with three sheets of plain A3 paper. You should use **both** sides of the paper. **Each** of the five parts (a) – (e) of the question you choose to answer should take up one side of paper.

When you are asked to **develop** a design you must show, using sketches and notes, the development and evaluation of a **range** of ideas into a single design proposal. The design proposal should be annotated to give details about materials, joining methods and important sizes.

7 Fig. 9 shows an incomplete idea for a piece of outdoor play equipment.

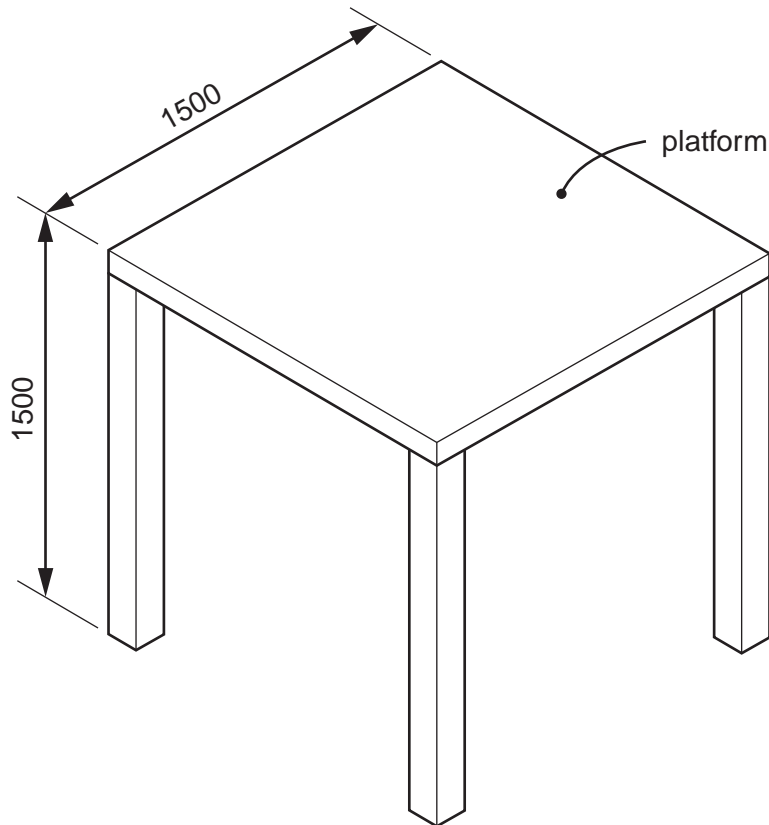

Fig. 9

- (a) Using notes and sketches, develop a design for steps with a safety rail which would allow children to climb up to the platform. [16]
- (b) Using notes and sketches, develop a design for a roof for the platform. [16]
- (c) Using notes and sketches, develop a design for a slide which allows children to slide from the platform to the ground. [16]
- (d) Using notes and sketches, develop a design which would prevent children falling from the platform. [16]
- (e) Produce a pictorial rendered drawing of the complete piece of outdoor play equipment which shows all of the features that you have designed in (a) – (d). [16]

- 8 Fig. 10 shows an incomplete idea for a card model of an articulated lorry.

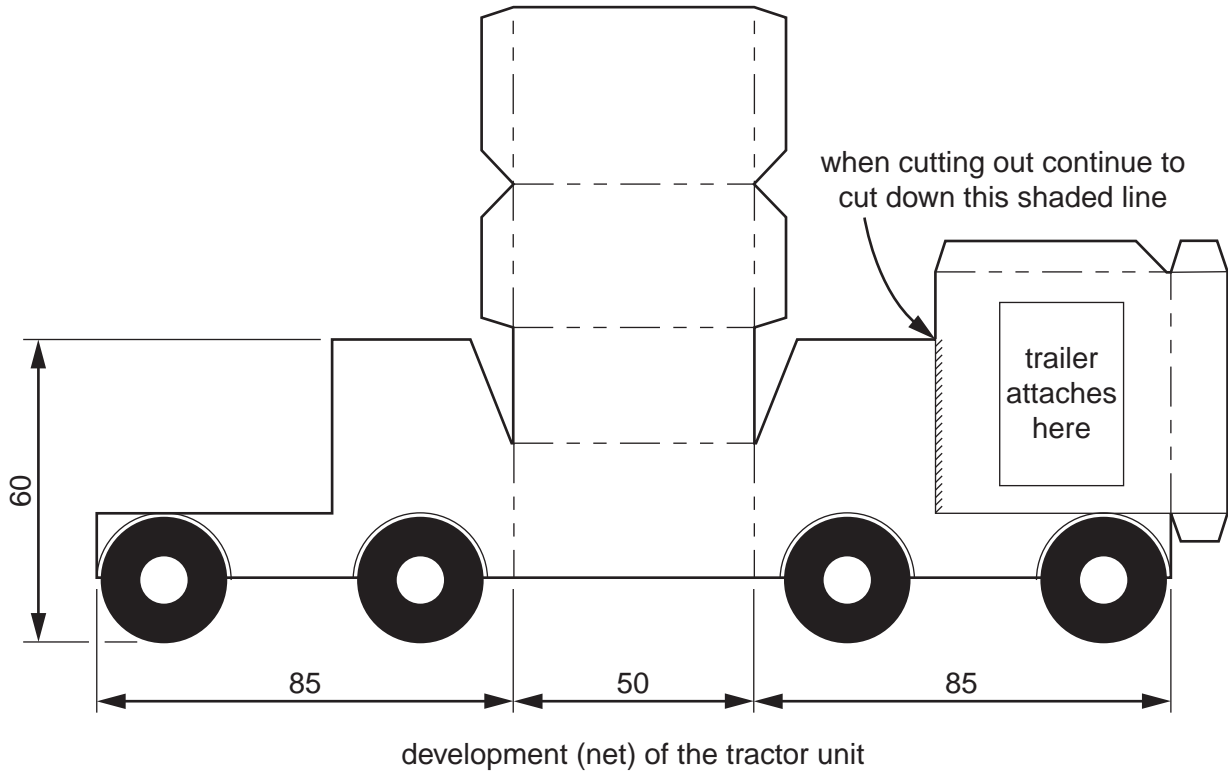

Fig. 10

- (a) Using notes and sketches, develop a design for the surface detail (windows, doors, lights etc.) to go on the development (net) required to make the tractor unit. [16]
- (b) Using notes and sketches, develop a design for a flatbed trailer. The design must include a method of attaching the trailer to the tractor unit so that it can be easily removed and replaced. [16]
- (c) Using notes and sketches, develop a design for a cuboid shaped container to go on the trailer. The design must include doors that open and close and a method of attaching the container to the trailer so that it can be easily removed and replaced. [16]
- (d) Using notes and sketches, develop a design for a logo to go on the side of the container. The logo must include the initials GT, a symbol linked to global transport and use a maximum of three colours. [16]
- (e) Produce a pictorial rendered drawing of the complete model of an articulated lorry which shows all of the features that you have designed in (a) – (d). [16]

- 9 Fig. 11 shows an incomplete idea for an animated display to go in a travel agent's window. Most of the display will be made from 9mm thick MDF (medium density fibreboard). The two main mechanisms will be driven by the battery operated electric motor shown in Fig. 11.

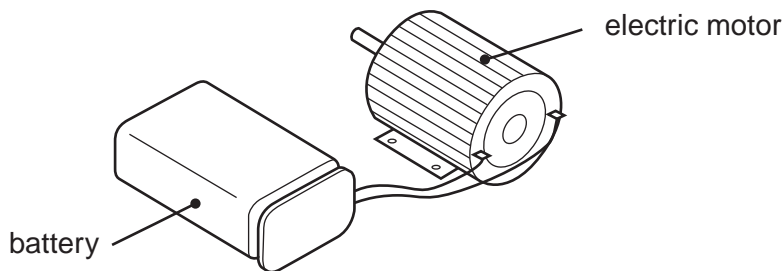
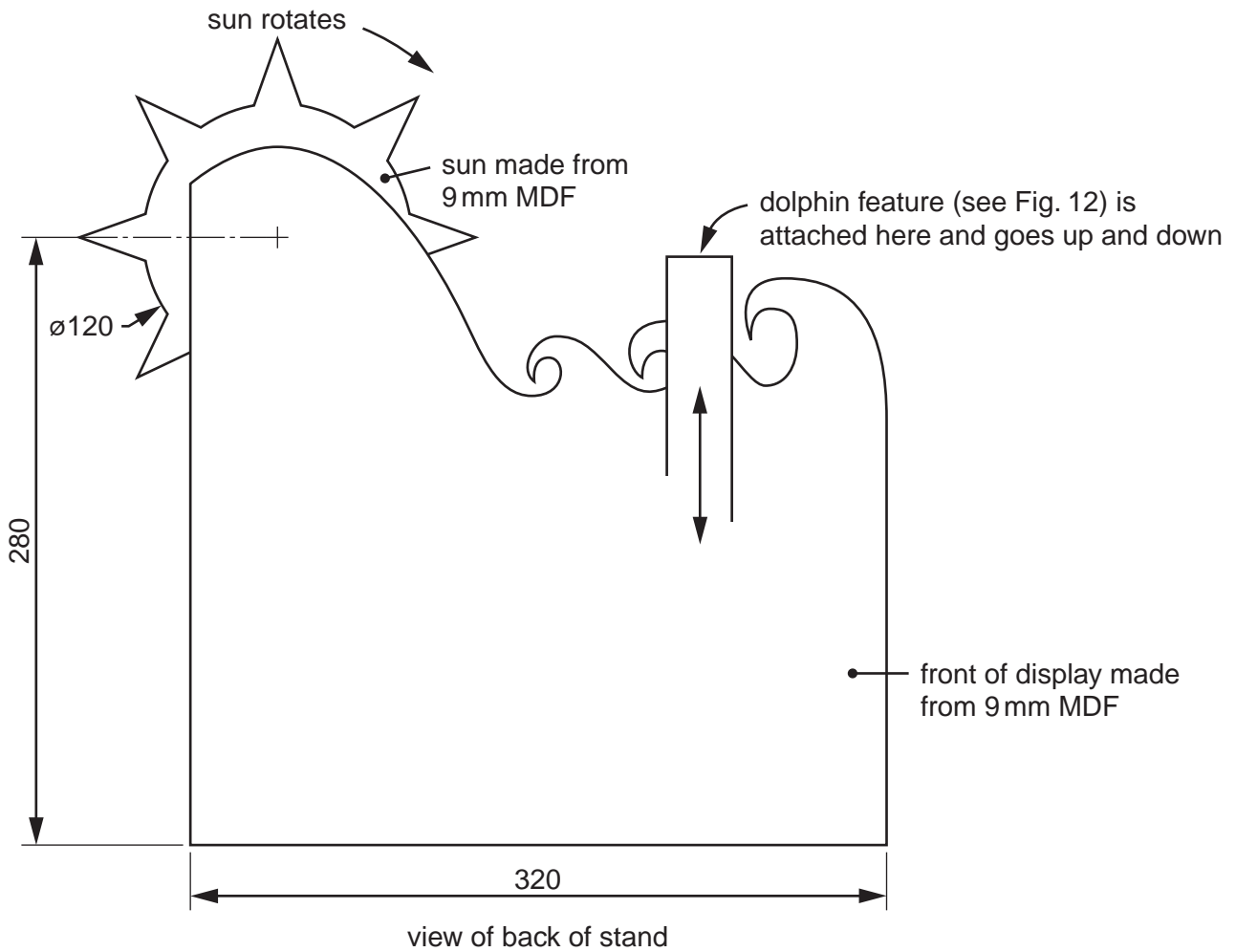

Fig. 11

- (a) Using notes and sketches, develop a design for a mechanism which makes the sun rotate. [16]
- (b) Using notes and sketches, develop a design for a mechanism which makes the dolphin feature go up and down. [16]

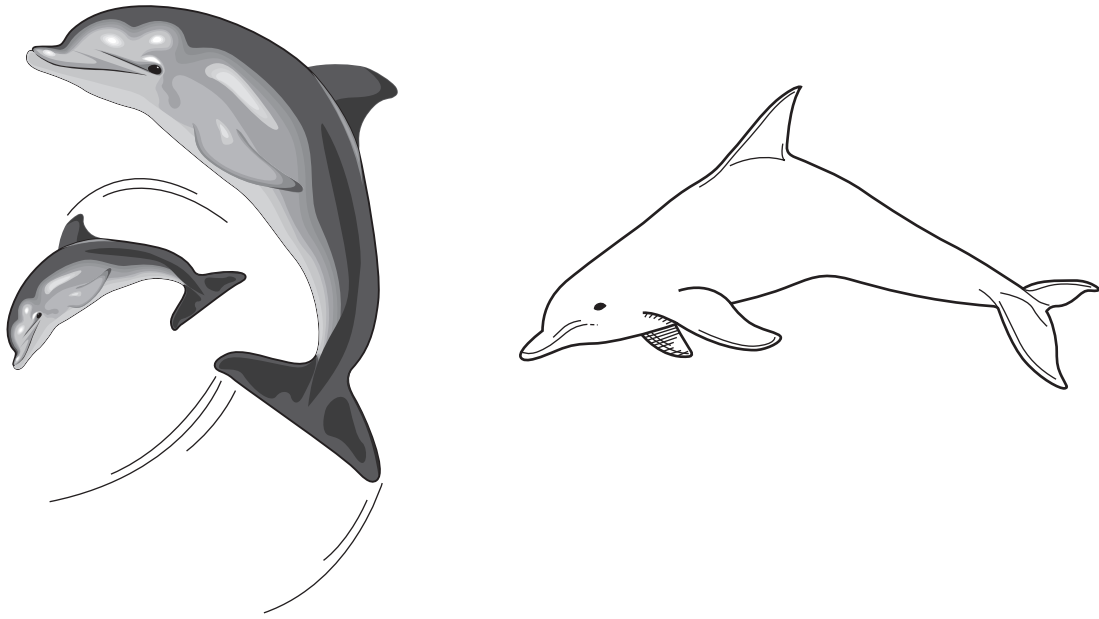

Fig. 12

- (c) Using notes and sketches, develop a design for the dolphin feature. The images shown in Fig. 12 have been provided to help you with your design work. The dolphin feature will be made from 9 mm MDF and include a feature which makes the tail move in some way. This movement **should not** be driven by the electric motor. [16]
- (d) Using notes and sketches, develop a design for a stand that will hold the front of the display in a vertical position and house the mechanisms, motor and battery. The stand should be open at the back so that the mechanisms can be seen and maintained. [16]
- (e) Produce a pictorial rendered drawing, viewed from the back, of the complete animated display which shows all of the features that you have designed in (a) – (d). [16]

Permission to reproduce items where third-party owned material protected by copyright is included has been sought and cleared where possible. Every reasonable effort has been made by the publisher (UCLES) to trace copyright holders, but if any items requiring clearance have unwittingly been included, the publisher will be pleased to make amends at the earliest possible opportunity.

University of Cambridge International Examinations is part of the Cambridge Assessment Group. Cambridge Assessment is the brand name of University of Cambridge Local Examinations Syndicate (UCLES), which is itself a department of the University of Cambridge.