

General Certificate of Education  
June 2004  
Advanced Level Examination



**DANCE**  
**Unit 4 Group Choreography**

**DAN4**

Practical Examination 2004

**In addition to this paper you will require:**  
a CD containing the musical accompaniment for  
Question 1.

To be distributed to candidates on or after 5 January 2004.

Time: At a time individually arranged between the visiting examiner and the centre.

**Instructions**

- Answer **one** question.

**Information**

- The maximum mark for this paper is 60.
- All questions carry equal marks.

---

Answer **one** question.

---

Choreograph a dance of between two and three minutes' duration for three, four or five performers on **one** of the following questions. You may not perform yourself, or take any part as, for example, accompanist or sound operator.

Prepare a programme note for your dance, of not more than 150 words, on a single side of an A4 sheet of paper.

- 1 Choreograph a dance using the musical accompaniment *La muerte del angel* (1970), A Piazzolla.

Source: Tangos by Piazzolla, A., Astor Piazzolla Tango/Concerto pour bandoneon, track 11, 2'53".  
79488135712 orchestra de cambra Teatre Lliure.

The music is on the accompanying CD.

(60 marks)

- 2 Choreograph a dance using:

‘freefall ... tremendous speed and serene stillness’.

Adapted from Akram Khan's programme note for *Rush* (2000), Queen Elizabeth Hall, London, 24–25 October 2002.

(60 marks)

- 3 Choreograph a dance using **one** of the following notated movement phrases as the basis for your dance. The entire phrase must appear at least once during the dance.

Phrases A, B, C and D are printed on pages 3, 4, 5 and 6. You should indicate in your programme note the phrase you have selected.

(60 marks)

Phrase A

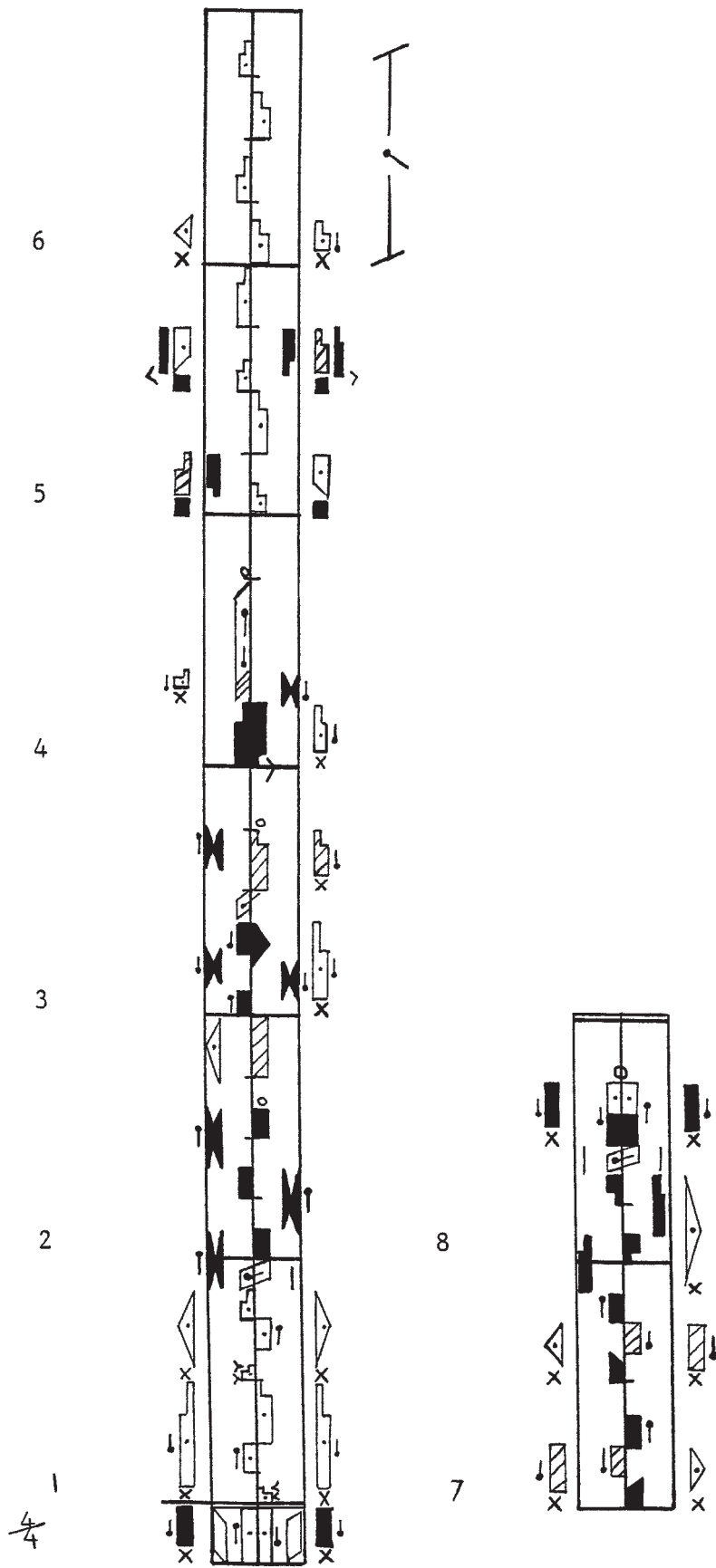

Turn over ►

Phrase B

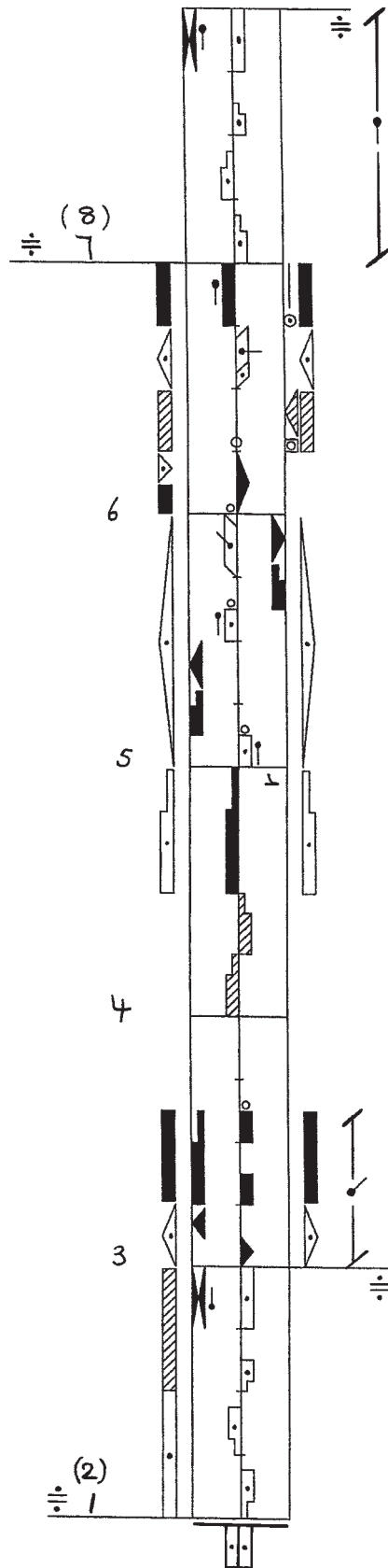

Phrase C

Allegretto  
Intro

The musical score is written on four staves. The first staff begins with a 4/4 time signature. The music is handwritten and includes several annotations: a '1' above the first measure, a 'φ' above the second measure, and a '2' below the third measure. The notation features various note values, rests, and phrasing slurs. The second staff contains a large slur over the first two measures and a '2' below the third measure. The third staff has a 'φ' above the first measure and a '2' below the second measure. The fourth staff has a 'φ' above the first measure. The score concludes with a double bar line at the end of the fourth staff.

Turn over ►

## Phrase D

Allegretto Intro

The image displays a handwritten musical score for a piece titled "Phrase D". The score is organized into four systems, each consisting of two staves. The tempo and mood are indicated as "Allegretto Intro".

- System 1:** The first staff begins with a treble clef and a 4/4 time signature. It contains a few notes and rests, with a fermata over the final measure. The second staff is mostly empty, with some faint markings.
- System 2:** The first staff contains several measures of music with notes, rests, and slurs. A circled measure contains a complex rhythmic figure. A  $\phi$  symbol is placed above the staff. The second staff has notes and rests, with a circled measure and a  $\phi$  symbol above it.
- System 3:** The first staff has notes and rests with slurs and  $\phi$  symbols. The second staff continues the musical line with notes and rests.
- System 4:** The first staff features notes and rests with slurs and  $\phi$  symbols, including a circled measure. The second staff concludes the phrase with notes and rests.

The score includes various performance markings such as slurs, accents, and circled measures, suggesting specific phrasing and articulation for the performer.

- 4 Choreograph a dance based upon the sculpture 'Encounter' (2002) and the text below, reproduced from the BBC News website, 13 October 2002.



The UK's tallest piece of public art since Nelson's Column will go on display on Sunday near Birchwood, Cheshire.

Encounter, a 91 feet (28 metres) high sculpture which depicts two people meeting, is being hoisted into place on a traffic island off junction 11 of the M62, which leads into the area.

Its creator Stephen Broadbent said it was designed to reflect the relationship between local business and the wider community. "It's a piece of public art, a marker for the junction into Birchwood," Mr Broadbent told the BBC, "and it's very much for the community here."

"It's got two figures represented in it encountering one another, up in the air, so it's representative of two people coming together, and it's also inspired by the birch tree and the bark peeling off the tree. It's a very slender, very elegant piece."

### **Workshop**

The statue, which was privately funded by the community, local companies and schools, was made in Birchwood itself.

"We've had a huge workshop in Birchwood where people have been able to witness the stages of its manufacture," Mr Broadbent said. "We've been trying to create that sense of ownership within the area, to give locals a sense of identity."

The sculpture – which has also been funded by mobile telecoms firm Hutchison 3G – will house a mobile phone mast.

*(60 marks)*

**END OF QUESTIONS**

---

**THERE ARE NO QUESTIONS PRINTED ON THIS PAGE**

**ACKNOWLEDGEMENTS OF COPYRIGHT-HOLDERS AND PUBLISHERS**

AQA gratefully acknowledges permission to use copyright material from the following in the production of this paper:

- Question 1: *La muerte del angel* (1970) from *Tangos* by Piazzolla, A.  
Astor Piazzolla Tango/Concerto pour bandoneon, orchestra de cambra Teatre Lliure.
- Question 3: Programme note for *Rush* by Khan, A (2002).
- Question 4: Text from BBC website <http://news.bbc.co.uk/1/hi/entertainment/arts/2324409.stm>, Sunday 13 October 2002.  
Photograph reproduced by permission of Stephen Broadbent, 2003 Broadbent.

Copyright © 2004 AQA and its licensors. All rights reserved.