

Computing

Advanced GCE A2 7820

Advanced Subsidiary GCE AS 3820

Mark Schemes for the Units

June 2008

3820/7820/MS/R/08J

OCR (Oxford, Cambridge and RSA Examinations) is a unitary awarding body, established by the University of Cambridge Local Examinations Syndicate and the RSA Examinations Board in January 1998. OCR provides a full range of GCSE, A level, GNVQ, Key Skills and other qualifications for schools and colleges in the United Kingdom, including those previously provided by MEG and OCEAC. It is also responsible for developing new syllabuses to meet national requirements and the needs of students and teachers.

This mark scheme is published as an aid to teachers and students, to indicate the requirements of the examination. It shows the basis on which marks were awarded by Examiners. It does not indicate the details of the discussions which took place at an Examiners' meeting before marking commenced.

All Examiners are instructed that alternative correct answers and unexpected approaches in candidates' scripts must be given marks that fairly reflect the relevant knowledge and skills demonstrated.

Mark schemes should be read in conjunction with the published question papers and the Report on the Examination.

OCR will not enter into any discussion or correspondence in connection with this mark scheme.

© OCR 2008

Any enquiries about publications should be addressed to:

OCR Publications
PO Box 5050
Annesley
NOTTINGHAM
NG15 0DL

Telephone: 0870 770 6622
Facsimile: 01223 552610
E-mail: publications@ocr.org.uk

CONTENTS

Advanced GCE Computing (7820)

Advanced Subsidiary GCE Computing (3820)

MARK SCHEMES FOR THE UNITS

Unit/Component	Page
2506 Introductory Computer Systems	1
2508 Computer Systems Development and Practical Applications	7
2509 Systems Software Mechanisms	17
2511 Integrated Information Systems	22
Grade Thresholds	28

2506 Introductory Computer Systems

- 1 (a)
 - List of choices made available which...
 - user can tick/point to/click on
 - leading to other choices...
 - and ultimately to the desired choice
 - Limited number of choices available at a time
 - Restricts ability of user to access other parts of the system. [3]
- (b) (i) Eg:
 - Information system
 - Simple to use/requires no computer knowledge/user friendly
 - Limits the peripherals necessary to use it
 - Can restrict access
 - Not restricted to text/can use icons for choices. [3]
- (ii)
 - Hard drive
 - In order to store the HCI and the details of results of searches
 - To store records of use of system.

 - Touch screen to act as both input and output
 - Simple device to use
 - Can be used in open air
 - Proof against vandalism.
- NB other responses acceptable if justified. Justification must be earned before device.
(2 marks per device) [4]
- 2 (a)
 - Not (necessarily) unique (cao) [1]
- (b)
 - Not in (a logical) order (cao) [1]
- (c) BLACKFORD
GREIG
LONG
LYNCH
ROUSE
(Accept reverse order) [1]
- Easier to search file for a student. [1]

- 3 (a)
 - To turn the source code into.../HLL code
 - the object code/machine code/binary
 - because it is a form that the computer can understand
 - check for errors. [2]
- (b)
 - Identifies keyword/reserved word in command
 - If not in its table of reserved words...
 - identifies variable name
 - If not in table of names/doesn't follow rules for variable names...
 - check the syntax for a statement
 - If statement doesn't follow rules
 - Report error. [3]
- (c)
 - Use of meaningful names
 - So that a person does not need to be referring constantly to a table
 - Variables are self explanatory.

 - Indentation/groups of instructions are indented
 - So that it is obvious that instructions go together/making the structure evident.

 - Modularity
 - Splits the algorithm into more easily understandable amounts
 - Result of a top down approach.
- (2 marks per technique, max 2 techniques)** [4]
- 4 (a) (i) Set of instructions used for loading the program which starts up the computer/program which starts to load the OS. [1]
- (ii)
 - Necessary to be present when computer switched on
 - Contents of ROM are permanent
 - Contents of RAM are lost when power off. [2]
- (b)
 - (Part of) OS (currently in use)
 - (Part of) (application) software currently in use
 - (User) data being used. [3]
- (c) (i)
 - Does not alter for life of washing machine
 - Keeps hardware simple/does not require additional storage
 - Does not require load up time/available immediately
 - Keeps software safe/tamper proof
 - Program small/simple. [3]
- (ii)
 - Processor requires work space
 - Processor can only use data present in RAM
 - Need for small amount of user input to system. [2]

- 5 (a) (i) 01011101 (cao)
(1 mark per nibble) [2]
- (ii) 135 (cao)
(1 mark for 1, and 1 mark for 35) [2]
- (iii) • Binary digits taken from right in groups of 3
• Then groups of 3 turned into decimal digits
• These decimal digits are written together to give octal representation. [2]
- (b) (i) 10100011 (cao)
(1 mark per nibble) [2]
- (ii) 10110011 (cao)
(1 mark per nibble) [2]
- (iii) 01010110 (cao)
(1 mark per nibble) [2]
- (iv) (+)86
The result is too large (magnitude) for a single byte. [2]
- 6 (a) (i) • To input data to the system
• To encode the data in some way
• To transmit the data as electrical pulses to the processor. [2]
- (ii) • Outputs information (from the processor)
• In human understandable form
• Or in a form suitable for reprocessing by the computer at a later stage. [2]
- (b) (i) • Set of symbols...
• That a computer can uniquely recognise...
• consisting of letter/digits/punctuation/control characters/ graphic characters/... [2]
- (ii) • Character stored as binary number/code...
• each character uses one byte/a fixed number of bits...
• each code is unique to that character
• Typical example code ASCII/EBCDIC. [2]
- (1 mark each, max 2 per doty) [4]

- 7 (a)
 - Original task split into smaller tasks/modules...
 - Which are themselves split up into smaller tasks/modules...
 - Until each task can be considered as one step in the solution (algorithm). [2]
- (b) (i) Using test data to compare actual result to expected result. [1]
- (ii) To follow paths through the software/to see if logic is correct. [1]
- (c) Advantage
- Smaller sections of code mean that...
 - testing can be more targeted...
 - and that errors can be identified more easily
 - different modules can be tested separately/less code to test at a time.
- Disadvantage
- Modularisation means that the modules must be linked
 - This provides another level of testing that must be carried out/links must be tested
 - Requires a driver program to run the module.
- [4]

- 8 (a) (i)
 - Computers connected individually to...
 - central hub/server
 - peripherals
 - central file store. [3]
- (ii)
 - Machines connected to central backbone/through machines
 - Terminators on backbone
 - Peripherals
 - Central file store/server. Must receive first mark point before getting other points. [3]
- (b)
 - Modem/high speed/large bandwidth digital line/router/gateway
 - To provide appropriate type of signal for communication/to provide appropriate medium for communication. [2]
- (c)
 - Parity
 - Either all bytes have an odd number of ones or all have an even number of ones...
 - set by the parity bit
 - If an error occurs then the byte will have the wrong parity
 - Mention of failure when even number of errors/Parity blocks
 - Check sum
 - Data in bytes is added
 - Ignoring any carry out of byte
 - Result is sent with data bytes
 - Calculation redone at receiving end and compared. (1 method, 1 mark each, max 4) [4]
- (d) (i)
 - Additional network traffic across
 - Media chosen for small network
 - Bottlenecks in system which many are trying to use simultaneously
 - Like printers/databases/software. [2]
- (ii)
 - Popular items like databases/software access
 - Are held on different machines/servers
 - Dedicated printer server created
 - Parts of database stored on machines most likely to use that part. [2]

9 (a) 6, 9, 12, 15, 5
(1 mark for 6, 9, 12, 15, and 1 mark for 5) [2]

(b) Eg NUMBER = 0
REPEAT
 NUMBER = NUMBER +1
 ANSWER = NUMBER *3
 OUTPUT ANSWER
UNTIL NUMBER = 5
(OUTPUT NUMBER)
END

Mark points (must use a repeat...until loop):

- Initialise NUMBER
- Correct incrementing to give 1 to 5
- Correct use of REPEAT... UNTIL
- With correct condition

[4]

Total = 90 (86+4) marks

2508 Computer Systems Development and Practical Applications

Question	Answer	Mark
1	<p>(a) Any 2 advantages and 2 disadvantages for interview and questionnaire from below, max 8.</p> <p>Interviews Advantage:</p> <ul style="list-style-type: none"> • user can express their opinions in a detailed way • more facts may come to light as the user answers questions • user may feel valued by the personal nature of the interview • they can extend questions. <p>Disadvantage:</p> <ul style="list-style-type: none"> • time consuming for analyst to gather facts • users may not tell the truth if they feel intimidated • suggest answers the analyst may want. <p>Questionnaires Advantage:</p> <ul style="list-style-type: none"> • efficient in terms of time • useful when a little information is required • they can be anonymous. <p>Disadvantage:</p> <ul style="list-style-type: none"> • difficult to design • inflexible opportunities to respond • low return rate from staff. 	
	<p>(b) (i) and (ii) 1 mark for method and max 1 for one advantage and one disadvantage</p> <p>Observation Advantage:</p> <ul style="list-style-type: none"> • allows the analyst to see a current process at first hand • analyst can get a “feel” of user competence and abilities in doing a task • analyst can get a better idea of time required to do a task, constraints and strengths of current system. <p>Disadvantage:</p> <ul style="list-style-type: none"> • users may respond differently if they are being observed • lack of interaction between analyst and user. 	[8]

Question	Answer	Mark
	<p>Record/document inspection</p> <p>Advantage:</p> <ul style="list-style-type: none"> analyst can get an idea of the volume of data stored see how data is collected and stored see what outputs are required can inspect how data is verified/validated. <p>Disadvantage:</p> <ul style="list-style-type: none"> limited interaction with potential users time consuming if there is a large volume of files. <p>Group meetings/interviews</p> <p>Advantage:</p> <ul style="list-style-type: none"> quicker than interviews, as you can get group opinions true picture of what's actually happening, which may not be the same as how management are thinking. <p>Disadvantage:</p> <ul style="list-style-type: none"> individuals may not contribute a wide variety of thoughts making it difficult to establish user needs. 	[3]
(c)	<p>(i) Direct changeover</p> <p>Any 2 from:</p> <ul style="list-style-type: none"> old systems stops and the new system begins no overlap between systems or immediate no part changeover if new system fails old system cannot be used. 	[2]
	<p>(ii) Phased changeover</p> <p>Any 2 from:</p> <ul style="list-style-type: none"> new system could be used in a few areas of the health centre initially while some tasks continue to use the old system vital that the old system and the new system can share data the results could be compared against the other areas that use old system roll out the new system if successful... ...abandon the new system. 	[2]
	<p>(iii) Parallel changeover</p> <p>Any 2 from:</p> <ul style="list-style-type: none"> two systems run side by side for a period of time comparing results of two systems can happen if new system fails, old system can be used. 	[2]

Question	Answer	Mark
1	<p>(d) (i) Perfective maintenance Any 2 from:</p> <ul style="list-style-type: none"> • software is performing task specified • but the system may be too slow in response times • due to increase in volume of data • improving performance. <p>(ii) Adaptive maintenance Any 2 from:</p> <ul style="list-style-type: none"> • changing needs of the health centre system • identifying other user requirements • changes in legal requirements/government policy • changes in medical practice. <p>(e) Any 8 from:</p> <ul style="list-style-type: none"> • tip of the day idea • ... to improve user skills • the use of wizards • ... to perform tasks • links • ... to appropriate websites/pages • built-in tutorials • ... to provide training for users • search using keyword/phrase • ... on index • query a database • ... of help topics • direct email/instant messaging • ... to software provider • tool tips • ... to describe buttons • FAQs • ... search through previous problems and their solutions • user forum • ... to allow the user to share a question with other users 	<p>[2]</p> <p>[2]</p> <p>[8]</p>

Question	Answer	Mark
2	<p>Optical mark recognition Any 2 from:</p> <ul style="list-style-type: none"> • scanner reads the reflected light from marks • marks made at specified points • on specially designed forms • marks equate to pre-set values • once read, sent for processing. 	[2]
	<p>Use Any 1 from:</p> <ul style="list-style-type: none"> • national lottery • multiple choice tests • school register • meter readings. 	[1]
	<p>Sensor Any 2 from:</p> <ul style="list-style-type: none"> • electronic equipment • responds to a physical property such as temperature • converts energy from one form to another • usually analogue to digital • collects data at regular intervals 	[2]
	<p>Use Any 1 from:</p> <ul style="list-style-type: none"> • temperature • humidity • magnetic tilt switches. 	[1]
	<p>Magnetic swipe card Any 2 from:</p> <ul style="list-style-type: none"> • data can be read from the stripe • by a magnetic stripe reader • the stripe can only store a small amount of data • the stripe consists of a thin layer of magnetic tape similar to that in a video/music tape. 	[2]
	<p>Use Any 1 from:</p> <ul style="list-style-type: none"> • credit card • bank card • loyalty card. 	[1]

Question	Answer	Mark
3	<p>(a) Any 2 from:</p> <ul style="list-style-type: none"> • process of checking data done manually (by humans) • It normally involves checking the data that appears on the screen with the data on the source document/visual checking • a method of double-entry can be used • whereby two people enter the same data (double entry) • results are cross-referenced to see if there are mistakes. 	[2]
	<p>(b) Any 3 checks from below, max 6</p> <p>Range check:</p> <ul style="list-style-type: none"> • check lower and upper limits of the product number • ensure the number lies between 1000 and 4999. <p>Check digit:</p> <ul style="list-style-type: none"> • adding an extra digit to the product number • ...which is calculated from product number. <p>Existence check:</p> <ul style="list-style-type: none"> • to check that a product number appears/exists • ...in the file or field in the computer system. <p>Format/Character/Type check/Picture/Mask:</p> <ul style="list-style-type: none"> • to check all characters are of the correct type • they should be integers. <p>Field length check:</p> <ul style="list-style-type: none"> • the number of characters entered is within the pre-defined limit • the number entered must be 4 characters. 	[6]
	<p>(c) (i) Any 2 from:</p> <ul style="list-style-type: none"> • hash total is a total of a numeric field • from each document in a batch • whereby the total is used to check input but has no other relevance • hash total is recalculated when batch is processed and compared with the original total • meaningless total, only used for validation • batch total is a meaningful total of a field • from each document in a batch • which can be used to check input • it can also be used to total the number of orders in a batch. 	[2]
	<p>(ii) • Example of hash: Add up all the product numbers and enter the total.</p>	[1]
	<p>• Example of batch: total number of stock orders in the batch.</p>	[1]

Question	Answer	Mark
3	<p>(d) Any 2 from: Advantage:</p> <ul style="list-style-type: none">• designed to do exactly what the user needs• fits user requirements exactly• programs can be written to run on existing hardware• comply with new hardware purchased• minimal change to working procedures of organisation• user support can be geared to meet user needs• no excess functionality• sell copies to other similar users to recoup development costs• program maintenance may be easier. <p>Any 2 from: Disadvantage:</p> <ul style="list-style-type: none">• not readily available• no third party user documentation available• payment of full development costs• not tried and thoroughly tested• no availability of third party training.	[2]
	<p>(e) Any 3 from:</p> <ul style="list-style-type: none">• natural way for humans to communicate• minimal amount of training for user• user can use key words to trigger off whole statements• people with disabilities can use this system• “hands free”- allows users to do other activities.	[3]

Question	Answer	Mark
4	(a) Batch processing	[1]
	<p>Description</p> <p>Any two from:</p> <ul style="list-style-type: none"> • employee hours are collected over a period of time (weekly/monthly) • stored as an off-line transaction file • input as a batch • processed as one run at time convenient to the computer system • each transaction is completed before the next one begins • at a time when the computer is not being used interactively (such as night time) • batch of payslips produced. 	
	<p>Reason</p> <p>Any one from:</p> <ul style="list-style-type: none"> • large quantities of data • same processing for all • time of processing is not critical • no user intervention is required during processing. 	[2]
	(b) Real time/rapid response/transaction processing/on-line	[1]
	<p>Description</p> <p>Any two from:</p> <ul style="list-style-type: none"> • data is processed as quickly as possible • short time delay • record locking occurs • output happens immediately • system is updated before next transaction • confirmation of seat details are sent to the user almost immediately. 	[1]
	<p>Reason</p> <p>Any one from:</p> <ul style="list-style-type: none"> • booking needs to be processed as quickly as possible • need to lock Record • need to prevent double booking. 	[2]
		[1]

Question	Answer	Mark
5	<p>(a) Any 2 from:</p> <ul style="list-style-type: none">• requires the user to learn a large number of commands• it also requires the ability to join commands to form instructions• the syntax in the command is critical• will not operate if typed incorrectly• not easy to use by an inexperienced user.	[2]
	<p>(b) Any 3 from:</p> <ul style="list-style-type: none">• windows• icons• menus (pop-up/pull down)• pointer/pointing device• help facility• hot keys• dialogue boxes• toolbars• ability to use a command line.	[3]

Question	Answer	Mark
6 (a) (i)	<p>Any 2 from:</p> <ul style="list-style-type: none"> • piece of software • which manipulates large quantities of data • to produce information • which is useful for managers • which helps in decision making • at different levels (operational, tactical, strategic) within the hospital. 	[2]
(ii)	<p>Any 2 uses from below, max 4</p> <ul style="list-style-type: none"> • allow hospital/ward managers to make well informed decisions • such as the number of nurses required for wards.... • protects the hospital managers • from information overload (about patient details) • allows for future planning for medical operations/resources • to be based on more precise information • to calculate future budget requirements • based on financial analysis over a previous period • analysing data • by producing results for decision making. 	[4]
(b) (i)	<p>Any 3 from:</p> <ul style="list-style-type: none"> • combines the knowledge of experts on a given subject • to form a knowledge base • using rules it has been given/rule base • can make inferences /diagnosis/ inference engine • provides a user interface to allow for communication. 	[3]
(ii)	<p>Any 1 from below, max 2</p> <ul style="list-style-type: none"> • to diagnose a patient's condition • using the inference engine • to recommend a suitable diet • by analysing current dietary problems • to assist a surgeon in performing an operation • by explaining what happens at each stage. 	[2]

Question	Answer	Mark
----------	--------	------

(c) **Max of 3 valid points – 1 mark for each point**

- personal data must be obtained and processed lawfully
- personal data must be held for specified purpose
- personal data must be used for the purpose it was collected for
- personal data must be accessible to the individual to whom it concerns
- personal data must be changed if it is incorrect
- personal data must be held using appropriate security measures
- personal data must be accurate and up-to-date
- personal data must be relevant
- personal data must not be kept longer than necessary.

Max of 3 marks if Candidate only refers to data protection legislation.

- hospital data protection policies should be published/given to patients
- patients should be informed why personal data is needed and what use it will be put to
- data should be obtained from the patient to ensure accuracy
- patient should be give permission if the data is required for any other purpose
- check boxes should be available to allow patients to opt-out of uses of their data
- patients concerns should be acted upon
- hospital staff should be aware of all data protection policies
- privacy of patient data should be understood by all employees
- staff should be held accountable for data protection policies
- reasonable steps should be taken by the hospital to ensure data held is accurate and up to date
- periodic checks should be made by the hospital to ensure the policies are adhered to.

[5]

Total = 90 (86 + 4) marks

2509 Systems Software Mechanisms

(1 mark per bullet point to maximum allowed)

- 1 (a)
 - allocates memory to processes/programs
 - allocates memory to data
 - protects processes from each other
 - reallocates memory when necessary
 - protects operating system
 - deals with allocation when paging
 - handles virtual memory
 - handles segmentation
 - enables memory to be shared
 - enables memory to be used efficiently [4]
- (b)
 - a map of where files are stored in backing store
 - provides addresses/pointers to (start of) files
 - holds file names
 - holds file sizes
 - identifies free space
 - stores access rights
 - is updated by operating system
 - is used when files are saved, deleted or accessed [4]
- (c)
 - enables user to find an object...
 - when given any one of its attributes
 - provides access to each user's personal files
 - provides access to shared files
 - which may be read-only
 - allows user to create sub-folders
 - protects data from unauthorised access [4]
- 2 (a) (i)
 - syntax analysis
 - code generation [2]
- (ii)
 - source code is used as input
 - tokens are created...
 - from reserved words/standard components
 - variable names are entered in symbol table
 - constants are entered in symbol table
 - unnecessary characters (spaces) are removed
 - comments are removed
 - error diagnostics are given
 - program is put in correct format for next stage (syntax analysis) [3]

- (b) • allows files/modules/libraries...
• that are already compiled
• to be combined with a (compiled) program
• & converted into an executable file
• completes address links/external references [3]
- (c) • the compiler creates an executable program
• executable program runs quickly
• executable program prevents customer from re-using code
• customer does not need a translator to run the program
• customer cannot modify the code [3]
- 3 (a) • program counter holds the address of the next instruction
• contents of program counter are copied to MAR
• program counter is incremented
• program counter is changed by a jump instruction
• for a jump instruction, address obtained from CIR to program counter [3]
- (b) • current cycle is completed
• interrupt register is checked
• priorities of current task & highest priority interrupt are compared
• (if interrupt is lower priority) interrupt is stored and process continues (if interrupt is higher priority...)
• contents of registers are put on stack
• interrupt is identified
• program counter is set to start location of ISR
• repeat above steps until end of process
• ...then run process with next highest priority
• if process is resuming
• ...then contents of registers restored from stack [6]
- (c) • single processor is split into parts
• each part handles one of fetch, decode, execute, reset
• when one instruction is in fetch part
• ...the previous is in decode part
• ...and a third is in execute
• if a jump instruction, clear pipeline
(accept diagram) [3]

- 4 (a) *Marks for*
- position 7 has new pointer 1
 - start 5, free 2
 - position 2 has new pointer 8
 - linked list and free list are correctly maintained
(or free 8 with pointer to 2 included correctly within free list)

	Position	Data	Pointer
	1	Edinburgh	4
	2	Durham	8
Start = 5	3	Manchester	6
	4	London	3
Free = 2	5	Bath	7
	6	York	0
	7	Cardiff	1
	8		9
	9		10
	10		0

[3]

- (b) (i)
- Check for full stack...
 - report error if full (& stop)
 - increment stack pointer
 - add new data item to position indicated by stack pointer
(*accept answers with stack pointer to first free space*)

[3]

- (ii)
- store contents of registers while processing an interrupt
 - parameter passing
 - store return addresses when calling procedures

[1]

5 (a)

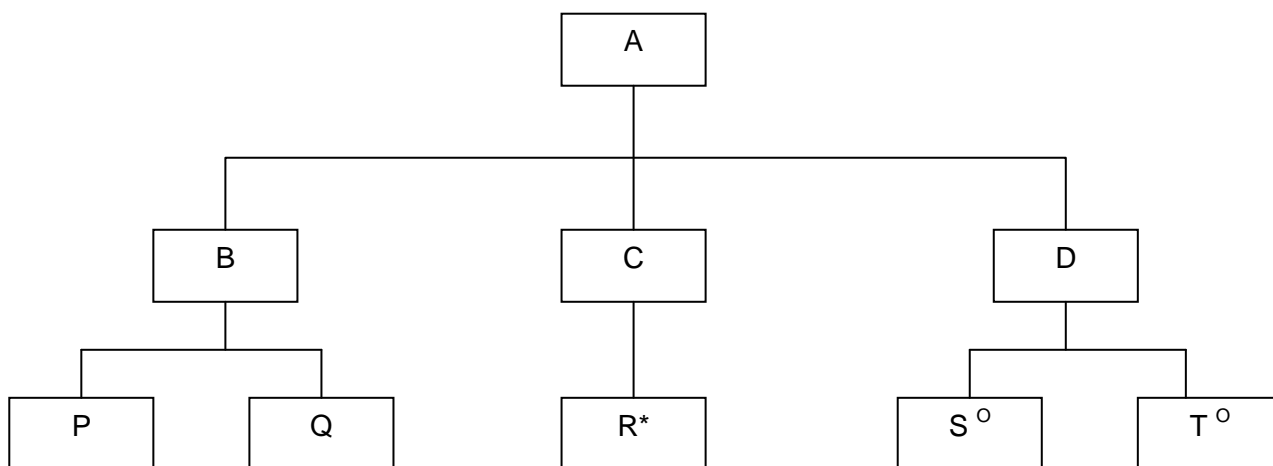

marks for the following additions on diagram

- (i) • P & Q only in order under B [1]
- (ii) • R only under C, either with * [1]
- (iii) • S & T only under D
• Symbol ° used with S & T [2]
- (b) (i) • No <SYMBOL> [1]
- (ii) • Includes <LOW><LOW> [1]
- (iii) • Ends with <UP> [1]
- (iv) 1 mark for each part of definition
• <VALUE>::=<DIGIT><DIGIT><DIGIT>|<VALUE><DIGIT>
(or <VALUE>::=<DIGIT><DIGIT><DIGIT>|<DIGIT><VALUE> [2]
- (v) 1 mark for each part of definition
• <CODE>::=<VALUE><UP><LOW>|<CODE><DIGIT> [2]
- 6 (a) • unique identifier
• eg ProductCode in Product/SupplierCode in Supplier [2]
- (b) • a foreign key is an attribute which is primary key in another table
• to provide a relationship between them
• eg SupplierCode is primary key in Supplier...
• and foreign key in Product [3]
- (c) 1 mark for each end of relationship (no additional tables)
- ```

graph LR
 Product[Product] --- Supplier[Supplier]
 style Product stroke-width:2px
 style Supplier stroke-width:2px

```
- [2]
- (d) • to provide easy access (to necessary data)...  
• ...for inexperienced users  
• ...for frequently performed tasks  
• to provide data security/keep data private [2]
- (e) • read-write access to update data (eg number in stock when an item is sold)  
• read-only access (to avoid corrupting data) while table is being updated by another salesman [2]

- 7 (a) 1 mark for definition, 1 mark is for the example
- (i) • instance of a class/real world entity  
• eg hisCar [2]
- (ii) • a template for a set of objects/defines state & behaviour for a set of objects  
• eg Car [2]
- (iii) • a program routine/procedure/function (contained within an object)/performs a particular task on data within the object  
• eg setPrice/setReg/showColour [2]
- (iv) • “data hiding”/the state of an object can only be changed by methods in the object’s class  
• eg must use setPrice to change the price of hisCar (*other example from question acceptable*) [2]
- (b) (i) • myCar = new Car [1]
- (ii) • myCar.setPrice:13500 [1]
- (iii) • myCar.showColour [1]
- 8 (a) •  $128 + 16 + 1/145$  [1]
- (b) (i) •  $1.0010 \times 10^1$   
• 10.01/move point one place to right  
•  $-2 + \frac{1}{4} = -1\frac{3}{4}$  (= -1.75)  
or  
•  $1.0010 \times 10^1$   
•  $-1 + \frac{1}{8} = -\frac{7}{8}$   
•  $-\frac{7}{8} \times 2 = -1\frac{3}{4}$  [3]
- (ii) • (pure binary) 10.1  
• 0.101 (insert leading 0 & move point 2 places left)  
• mantissa is 01010  
• exponent 010  
(max 2 if no working shown) [3]
- (iii) • value given is 7.5  
• new largest binary value is 01110111  
• convert to  $1110000 = 64+32+16 = 112$   
• more bits in exponent gives greater range  
• fewer bits in mantissa gives less accuracy [3]
- (iv) • to give a standard format/avoid duplicate representations of the same number [1]  
• maximise precision for size of mantissa  
• makes multiplication easier

[Total = 86+4 = 90 marks]



# 2511 Integrated Information Systems

- 1 (a) Hardware – physical parts of a computer/components of computer (system)  
 Software – programs/instructions that control the hardware

(Give 1 mark each)

[2]

- (b) Give 1 mark for the device and 1 mark for the purpose.

Input device:

- keyboard/keypad
- ... to input the price/to use if barcode reader not working/to input data
- barcode reader/scanner/laser scanner
- ... to read the barcodes (on boxes of shoes)
- magnetic stripe reader/chip and pin
- ... to read credit cards/loyalty cards/to pay bill
- touch screen
- ... to input further data/select options

Output device

- screen/VDU/monitor/LCD/LED
- ... to temporarily display price/total cost/change
- printer
- ... to print receipt
- speaker
- ...to indicate barcode read

[8]

- (c) (i) Give 1 mark for the diagram before insertion  
 Give 1 mark for the diagram after insertion  
 For example:

Before

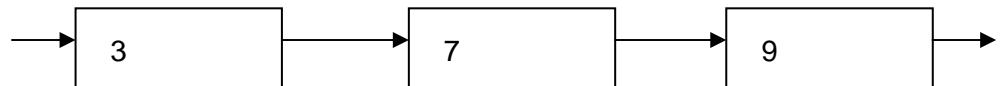

After

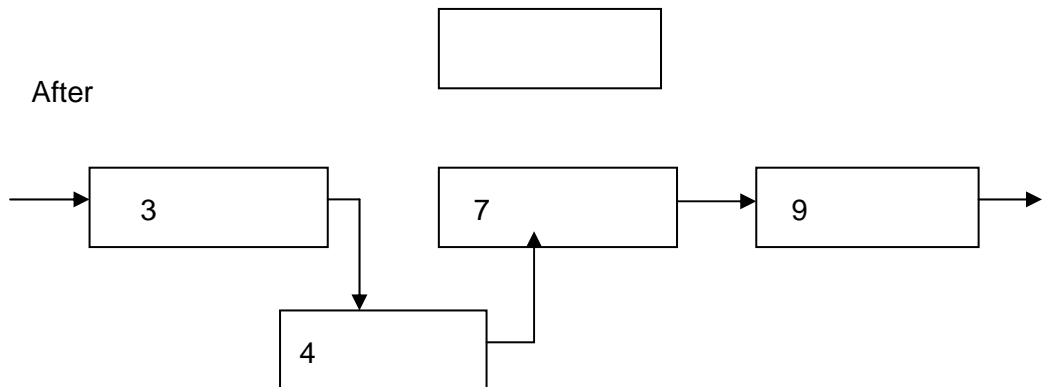

Give 1 mark per point to a maximum of 4

- If list is empty
  - insert data in new location
  - header points to this location
  - next pointer set to null.
- Else
  - Search/find list
  - until key to be inserted < key in next element in list
  - or end of list
  - change pointer in new to pointer in previous cell
  - change pointer in previous cell to new cell
  - or to null if end of list
  - adjust pointer in head of free list

[6]

(ii) Give 1 mark for a diagram such as

Before

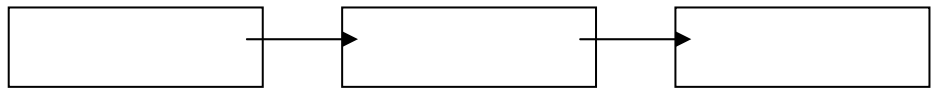

After

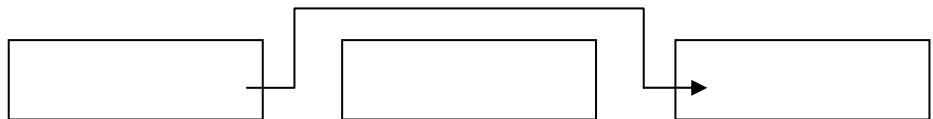

Give 1 mark per point to a maximum of 2

- search for item
- when it is found
- ...change previous pointer to pointer in deleted item
- ...or null if end of list
- if not found error

[3]

(iii) The records are in the same order/ordered sequentially

[1]

2 (a) (i) Give 1 mark for ONE of the following.

- Local Area Network
- A number of computers connected together over a small area

[1]

(ii) Give 1 mark per advantage and disadvantage to a maximum of 2 for advantage and 1 for disadvantage.

Advantages:

- sharing software
- sharing hardware
- sharing peripherals
- sharing a database/files/data
- users can use any computer
- ease of communication between computers/users

Disadvantage:

- initial cost
- maintenance
- more complex OS
- network can go down
- virus attacks

[3]

- (iii) Give 1 mark for ONE of the following
- a Wide Area Network
  - a number of LANs connected over a large geographic area
- [1]**
- (b) (i) A database that is stored in more than one location
- [1]**
- (ii) Give 1 mark for each advantage to a maximum of 2 and 1 mark for each disadvantage to a maximum of 2.
- Advantages:
- reduce vulnerability of a single massive database
  - increase service to users/customers
  - increase responsiveness
  - run on a smaller/less expensive computer
  - more efficient updating of database.
- Disadvantages:
- dependent on high quality telecommunications
  - ...which are vulnerable
  - local database can depart from central database standards/definitions
  - security problems
- [4]**
- (c) (i) Give 1 mark per point
- half-duplex: data transmission can only be in one direction at a time
  - hub: can only deal with one communication at a time
  - ...but must be in both directions (not at the same time)
- [3]**
- (ii) Give 1 mark per point
- full-duplex: data transmission in both directions simultaneously
  - switch: can deal with many transmissions
  - ...(in both directions) at the same time
  - extra switching circuitry
- [3]**
- (d) Give 1 mark per point to a maximum of 6 marks
- inspects each packet sent to it
  - builds up a list of addresses
  - determines if it belongs to local IP or IPX network
  - ...or remote network
  - if remote network
  - ...and router knows how to access it
  - ...it connects to remote network
  - reports errors
  - uses sophisticated algorithms
  - ...and routing protocols
  - ...to communicate with other routers
  - ...to determine best route
  - sends packet to correct location/port
- [6]**

- (e) Give 1 mark per point to a maximum of 4
- allows testing of individual layers
  - allows different systems to have different implementations of the layers
  - allows changing of individual layers
  - different devices can use different layers
  - each layer is (discrete and) independent
  - each layer provides a service to those above
  - each layer uses data from layer below
- [4]

- 3 (a) Give 1 mark per point to a maximum of 3 marks
- database stored as a single file/table
  - rows for each record
  - columns for each field
  - stored as a 2-D table
  - application/program dependent
- [3]

Give 1 mark per point to a maximum of 4 marks

- a set of tables
  - each row is an entity
  - each column is an attribute
  - tables are linked by relationships
  - ...using primary and foreign keys
  - different views of data can be created
  - independent of application
- [4]

- (b) (i) Give 1 mark for both table and 1 for each end of the relationship.

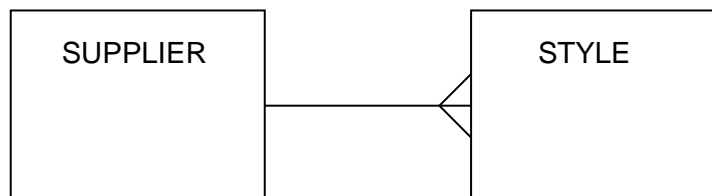

[3]

- (ii) Give 1 mark for each point
- primary key in STYLE
  - foreign key in STYLE is supplier ID
  - one other appropriate attribute eg colour
  - primary key in SUPPLIER
  - one other appropriate attribute in SUPPLIER eg name

Eg:

STYLE (Style ID, supplier ID\*, colour)  
 SUPPLIER (supplier ID, name, ...)

[5]

- (c) Give 1 mark for each point to a maximum of 3
- reduces data duplication
  - reduces data redundancy
  - reduces errors/data consistency
  - makes updating easier
  - speed of accessing data is quicker
  - reduces file size
  - different views of data can be created
  - easy to generate reports/queries
- [3]

(d) Give 1 mark for each point to a maximum of 2 for manager, 2 for shop assistant and a max of 3 overall.

Manager:

- needs to update the database
- ...when new stock arrives
- modify stock records when stock levels are incorrect
- update prices
- needs read/write access

Shop assistant:

- should not be allowed to change the database directly
- ...only when stock is sold
- ...and this should be automatic
- only needs read access to the stock database

[3]

4 Give 1 mark per point up to a maximum of 3 per application.

Updating stock:

- response time needs to be real time/very fast/immediate
- hardware needs to have high speed telecommunications/faster processor
- software needs to be able to search database rapidly/update the database in real time

[3]

Printing reports:

- response not urgent/batch processing
- hardware can run process off-line/out of hours
- software needs to use a batch processing (OS)/be able to analyse sales/statistical calculations

[3]

5

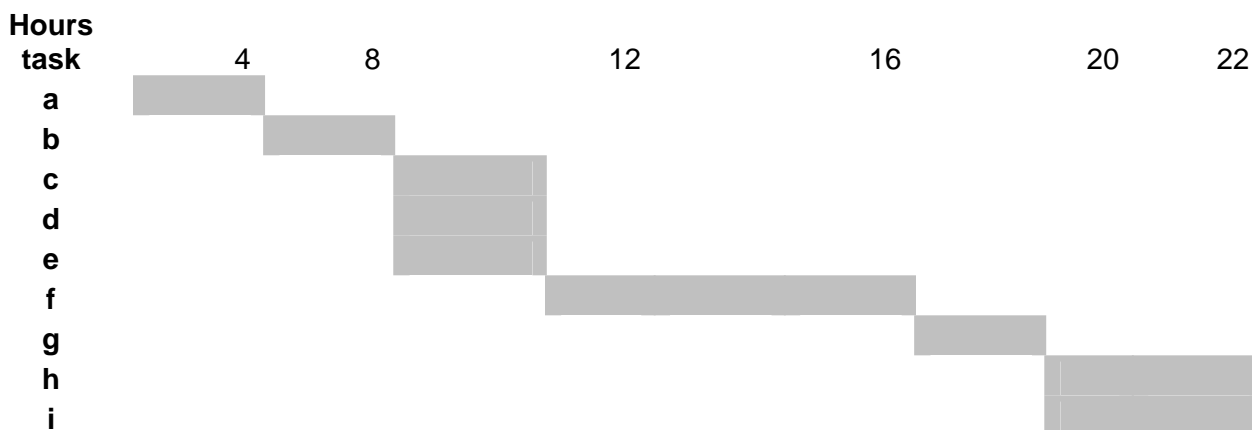

Give 1 mark for the scale showing time

Give 1 mark for b following a

Give 1 mark for c, d and e being parallel

...AND following b

Give 1 mark for f, g, h and i all being correct

Accept CPA diagram

Duration = 22 hours

[5]

[1]

- 6 Give 1 mark per point to a maximum of 7
- sensor uses satellite signals/GPS
  - ...to give position
  - autopilot uses position to calculate course
  - actuators used to change flaps – hence course
  - sensors used to measure pressure
  - ...autopilot then calculates height
  - actuators then adjust flaps to alter height
  - uses real time processing
  - repeatedly reads sensors
  - ...and uses actuators
  - ...very rapidly
  - accept details of adjusting roll
  - ...pitch
  - ...yaw
  - compare readings from sensors with preprogrammed values
- [7]**

**[Total = 86+4 = 90 marks]**

# Grade Thresholds

Advanced GCE Computing (3820/7820)  
June 2008 Examination Series

## Unit Threshold Marks

| Unit |     | Maximum Mark | A   | B  | C  | D  | E  | U |
|------|-----|--------------|-----|----|----|----|----|---|
| 2506 | Raw | 90           | 68  | 60 | 52 | 44 | 36 | 0 |
|      | UMS | 90           | 72  | 62 | 54 | 45 | 36 | 0 |
| 2507 | Raw | 120          | 102 | 91 | 80 | 69 | 58 | 0 |
|      | UMS | 120          | 96  | 84 | 72 | 60 | 48 | 0 |
| 2508 | Raw | 90           | 65  | 57 | 50 | 43 | 36 | 0 |
|      | UMS | 90           | 72  | 62 | 54 | 45 | 36 | 0 |
| 2509 | Raw | 90           | 71  | 62 | 53 | 45 | 37 | 0 |
|      | UMS | 90           | 72  | 62 | 54 | 45 | 36 | 0 |
| 2510 | Raw | 120          | 100 | 88 | 76 | 65 | 54 | 0 |
|      | UMS | 120          | 96  | 84 | 72 | 60 | 48 | 0 |
| 2511 | Raw | 90           | 62  | 56 | 50 | 44 | 39 | 0 |
|      | UMS | 90           | 72  | 62 | 54 | 45 | 36 | 0 |

## Specification Aggregation Results

Overall threshold marks in UMS (ie after conversion of raw marks to uniform marks)

|      | Maximum Mark | A   | B   | C   | D   | E   | U |
|------|--------------|-----|-----|-----|-----|-----|---|
| 3820 | 300          | 240 | 210 | 180 | 150 | 120 | 0 |
| 7820 | 600          | 480 | 420 | 360 | 300 | 240 | 0 |

The cumulative percentage of candidates awarded each grade was as follows:

|      | A    | B    | C    | D    | E    | U   | Total Number of Candidates |
|------|------|------|------|------|------|-----|----------------------------|
| 3820 | 10.2 | 27.7 | 50.3 | 70.9 | 85.2 | 100 | 854                        |
| 7820 | 13.1 | 36.3 | 59.4 | 82.1 | 96.4 | 100 | 623                        |

## 46 candidates aggregated this series

For a description of how UMS marks are calculated see:

[http://www.ocr.org.uk/learners/ums\\_results.html](http://www.ocr.org.uk/learners/ums_results.html)

Statistics are correct at the time of publication.

**OCR (Oxford Cambridge and RSA Examinations)**  
**1 Hills Road**  
**Cambridge**  
**CB1 2EU**

**OCR Customer Contact Centre**

**14 – 19 Qualifications (General)**

Telephone: 01223 553998

Facsimile: 01223 552627

Email: [general.qualifications@ocr.org.uk](mailto:general.qualifications@ocr.org.uk)

**[www.ocr.org.uk](http://www.ocr.org.uk)**

For staff training purposes and as part of our quality assurance programme your call may be recorded or monitored

**Oxford Cambridge and RSA Examinations**  
**is a Company Limited by Guarantee**  
**Registered in England**  
**Registered Office; 1 Hills Road, Cambridge, CB1 2EU**  
**Registered Company Number: 3484466**  
**OCR is an exempt Charity**

**OCR (Oxford Cambridge and RSA Examinations)**  
**Head office**  
**Telephone: 01223 552552**  
**Facsimile: 01223 552553**

© OCR 2008

