



## General Certificate of Education

# Computing 5511/6511

*CPT1 Computer Systems, Programming and Networking Concepts*

## Mark Scheme

*2005 examination - June series*

Mark schemes are prepared by the Principal Examiner and considered, together with the relevant questions, by a panel of subject teachers. This mark scheme includes any amendments made at the standardisation meeting attended by all examiners and is the scheme which was used by them in this examination. The standardisation meeting ensures that the mark scheme covers the candidates' responses to questions and that every examiner understands and applies it in the same correct way. As preparation for the standardisation meeting each examiner analyses a number of candidates' scripts: alternative answers not already covered by the mark scheme are discussed at the meeting and legislated for. If, after this meeting, examiners encounter unusual answers which have not been discussed at the meeting they are required to refer these to the Principal Examiner.

It must be stressed that a mark scheme is a working document, in many cases further developed and expanded on the basis of candidates' reactions to a particular paper. Assumptions about future mark schemes on the basis of one year's document should be avoided; whilst the guiding principles of assessment remain constant, details will change, depending on the content of a particular examination paper.

## Instructions to examiners

The following forms of notation should be used on candidates' scripts:

- Ticks - To indicate what is accepted as correct or creditworthy, placed in the body of the answer, and on diagrams;
- Underscoring - To identify errors/irrelevance in written answers;
- Crosses - to indicate a wrong answer;
- Brief comments - placed in at suitable points in the body of the text to amplify the marking;
- BOD - means benefit of the doubt and is used where the candidate's answer has been given a mark on the balance of probabilities that the candidate's answer has met the requirements of the mark scheme even though it could be interpreted differently;
- NE - means not enough and is applied to an answer that falls short of what is required;
- O/S - means outside the mark scheme. The candidate's answer is creditworthy but the answer does not match any of the answers on the mark scheme for the particular question. Nevertheless a mark is awarded;
- C/F - means carried forward. This arises when a candidate offers an answer that is not creditworthy in that part of the question but is creditworthy in a later part of the same question. The mark is carried forward to the part of the question that is creditworthy;
- C/B - means carried back. This is similar to a carry forward but the mark is carried back to an earlier part of the question.
- T/O - means talked out. The candidate's answer is contradictory.
- F/T - means followed through. If the candidate made a mistake in the earlier part of an answer, mark the answer using the correct method on their answer from the earlier part.

### ***The following notation is used in the mark scheme***

- ; - means a single mark;
- **A** - means an acceptable creditworthy answer;
- **R** - means reject answer as not creditworthy.
- **I** - ignore
- / - means alternative word or sub-phrase
- // - means alternative answer

1. (a) operating system;  
 utility program (*or an example of one*);  
 library program;  
 compiler/assembler/interpreter/translator;  
 driver;  
 user interface;  
**A** BIOS      **R** Any programming language      **3**

(b) Payroll;  
 Stock Control;  
 Production control;  
 Sales;  
 Invoicing;  
 Word processing;  
 Spreadsheet;  
 Database;  
 Desk top publishing;  
 Browser;  
 Or any appropriate application  
**R** e-commerce NE      **3**

**Total 6**

2. (a) (i) 

0	0	1	1	0	0	1	0	0	0	1	1	0	1	1	1
---	---	---	---	---	---	---	---	---	---	---	---	---	---	---	---

**1**

(ii) 

0	0	0	0	0	0	0	0	0	0	1	0	0	1	1	1
---	---	---	---	---	---	---	---	---	---	---	---	---	---	---	---

**1**

(iii) 

0	0	0	0	0	0	0	0	0	0	0	1	1	0	1	1
---	---	---	---	---	---	---	---	---	---	---	---	---	---	---	---

**1**

(b) Unicode is 16 bit code;      **1**

(c) 

1	0	0	1	1	0	0	1	1	0	0	1	1	0	0	1
---	---	---	---	---	---	---	---	---	---	---	---	---	---	---	---

1	1	1	1	1	1	1	1	1	1	1	1	1	1	1	1
---	---	---	---	---	---	---	---	---	---	---	---	---	---	---	---

**2**

**Total 6**

3. (a)

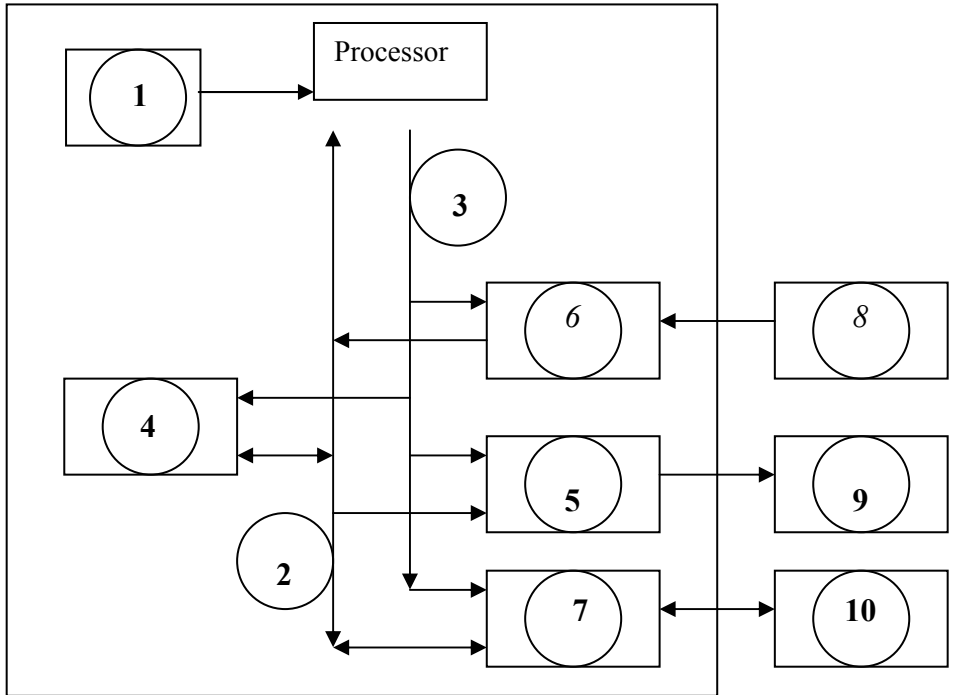

1 mark each for 1, 2, 3, 4.  
 1 mark for both 5 & 9  
 1 mark for both 7 & 10

6

(b) Machine code instructions/program stored in main memory; A RAM/IAS  
 Can be replaced by another program at any time;  
 A Fetched and executed; (*concept*)

1

**Total** 7

4. (a) (i) Analogue to Digital Converter;  
 A sound card A A-D Converter A ADC R MIDI

1

(ii) Microphone generates analogue signals;  
Computer/System requires digital/binary/discrete signals//  
Computer/System stores/processes sound in digital/binary form;

2

(b) 2 – Digital to Analogue Converter; A D-A Converter A DAC  
 A Sound card (but not if given in (a) (i))  
 3 – Speaker/ headphones;

2

(c) Sound wave is recorded/sampled at regular intervals;  
 Height/Amplitude/Height/Value of sound wave is represented by a  
 number/binary code/binary pattern;

2

	(d)	Number of bits used to store each value// range of values/numbers/binary codes/binary patterns; Sampling rate// frequency of sampling // time between samples/values; R Quality of equipment	2
		<b>Total</b>	<b>9</b>
5.	(a)	(i) Name: <u>Start</u> Bit; Purpose: Synchronise receiver;	2
		(ii) Name: <u>Parity</u> Bit; Purpose: Perform parity check// check for errors in transmission; A Prevent errors	2
		(iii) Name: <u>Stop</u> Bit; Purpose: Allow start bit to be recognised// Allow receiver to process received bits; A Indicates end of data	2
	(b)	(i) the number of signal/voltage changes per second; A rate at which signals are sent; A rate at which voltage changes;	1
		(ii) number of bits per second / unit of time; R the rate at which bits are sent ( <i>question paraphrased</i> )	1
		(iii) Range of frequencies a channel can handle; A <u>maximum</u> line speed; A <u>maximum</u> transmission speed;	1
	(c)	A signal can contain one or more bits; Bit rate can be higher than baud rate; bit rate = baud rate * number of bits per signal change;;	2
		<b>Total</b>	<b>11</b>
6.	(a)	(i) Name// Hours// RateofPay;	1
		(ii) Total;	1
	(b)	Do not use any global variables// use only local variables and/or parameters; A Can be compiled independently // can be placed in a library	1
	(c)	Local and global variables with the same name can be misidentified// difficult to test individual procedures/ functions// Not clear that as a side-effect of executing procedure/function a global variable could change its value;	1
		<b>Total</b>	<b>4</b>
7.	(a)	(i) First In First Out; <span style="float: right;">or by description</span>	
		(ii) Last In First Out; <span style="float: right;">or by description</span>	
			2

(b)

	FIFO	LIFO
Queue	✓	
Stack		✓

2

(c)

Reverse the contents of a queue/list;  
 Push all contents of queue/list onto stack then pop them off into a new queue/list;  
 Procedure/function calls;  
 Local variables;  
 Parameters;  
 Return Address;  
 Volatile environment; **A** register contents  
 State 1 Describe 1

2

(d)

list of elements inserted into tree;  
 to allow rapid/fast searching of the data;  
 to output sorted/ordered data;

2

**Total 8**

8.

(a)

(i) world-wide collection of networks/computers using TCP/IP;  
world wide collection of networks/ gateways/ servers/ computers using a common set of telecommunications protocols to link them together;  
world-wide collection of networks/ computers using the same protocol;  
world-wide collection of networks/computers using a standard protocol;

1

(ii) collection of servers using Hypertext Transfer Protocol/HTTP//  
 collection of data files/ documents using Hypertext Mark-up Language/  
 HTML/ XHTML/ XML;

1

(iii) computers connected within a small geographical area/building/site;  
**A** computers connected using local area network/LAN protocols;

1

(iv) computers connected over a large geographical area;  
**A** computers connected using wide area network/WAN protocols;

1

(v) Network providing Internet facilities within an organisation/  
 LAN using Internet protocol;

1

(b)

(i) any valid domain name, e.g. aqa.ac.uk; **R** www.aqa.ac.uk

1

(ii) any valid address in the range 0.0.0.0 to 255.255.255.255;

1

**Total 7**

9. (a) 1 mark for each correct entry

6

New	Last	Ptr	Values				
			[1]	[2]	[3]	[4]	[5]
6	3	1	4	7	9		
		2					
	2					9	
	1				7		
				6			

**Total 7**  
**Grand Total 65**

(b) Insert 6/a value into the array/ in the correct position;

1

**Total 7**

**Grand Total 65**