



UNIVERSITY OF CAMBRIDGE INTERNATIONAL EXAMINATIONS
 General Certificate of Education
 Advanced Subsidiary Level and Advanced Level

CANDIDATE
 NAME

CENTRE
 NUMBER

--	--	--	--	--

CANDIDATE
 NUMBER

--	--	--	--



BIOLOGY

9700/21

Paper 2 Structured Questions AS

May/June 2010

1 hour 15 minutes

Candidates answer on the Question Paper.

No Additional Materials are required.

READ THESE INSTRUCTIONS FIRST

Write your Centre number, candidate number and name in the spaces provided at the top of the page.

Write in dark blue or black pen.

You may use a soft pencil for any diagrams, graphs or rough working.

Do not use staples, paper clips, highlighters, glue or correction fluid.

DO **NOT** WRITE IN ANY BARCODES.

Answer **all** questions.

At the end of the examination, fasten all your work securely together.

The number of marks is given in brackets [] at the end of each question or part question.

For Examiner's Use	
1	
2	
3	
4	
5	
6	
Total	

This document consists of **14** printed pages and **2** blank pages.



Answer **all** the questions.

1 (a) Fig. 1.1 shows the breakdown of a molecule of sucrose.

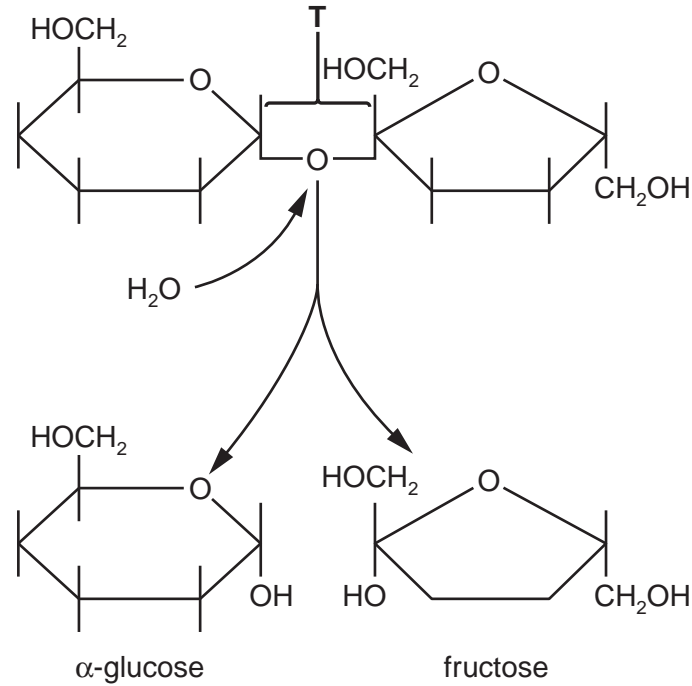

Fig. 1.1

(i) Name the bond indicated by T.

.....[1]

(ii) State the name given to this type of reaction in which water is involved.

.....[1]

(iii) State two roles of water **within plant cells** other than taking part in breakdown reactions.

1.

2.[2]

(b) Enzymes are globular proteins.

State what is meant by the term *globular*.

.....

[2]

(c) The reaction shown in Fig. 1.1 is catalysed by the enzyme sucrase. Fig. 1.2 shows an enzyme-catalysed reaction.

For
Examiner's
Use

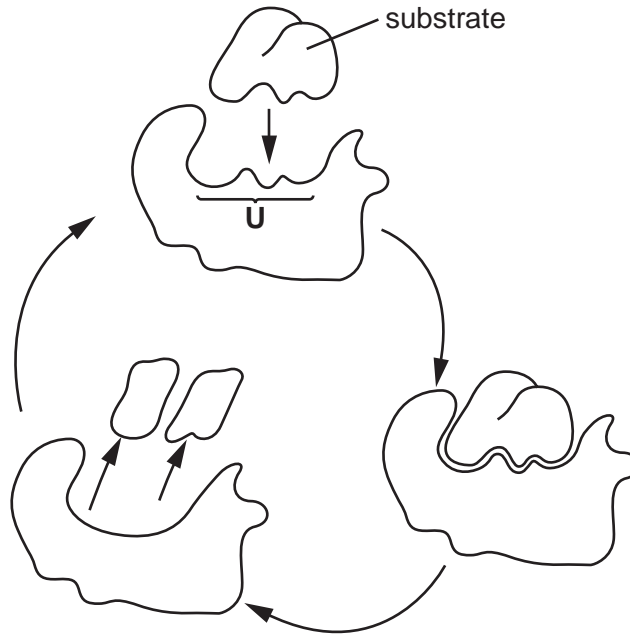

Fig. 1.2

(i) Name the part of the enzyme labelled **U**.

.....[1]

(ii) With reference to Fig. 1.2, explain the mode of action of enzymes.

.....
.....
.....
.....
.....
.....
.....
.....
.....
.....
.....[4]

[Total: 11]

- 2 Fig. 2.1 is a section of an alveolus and surrounding tissue.

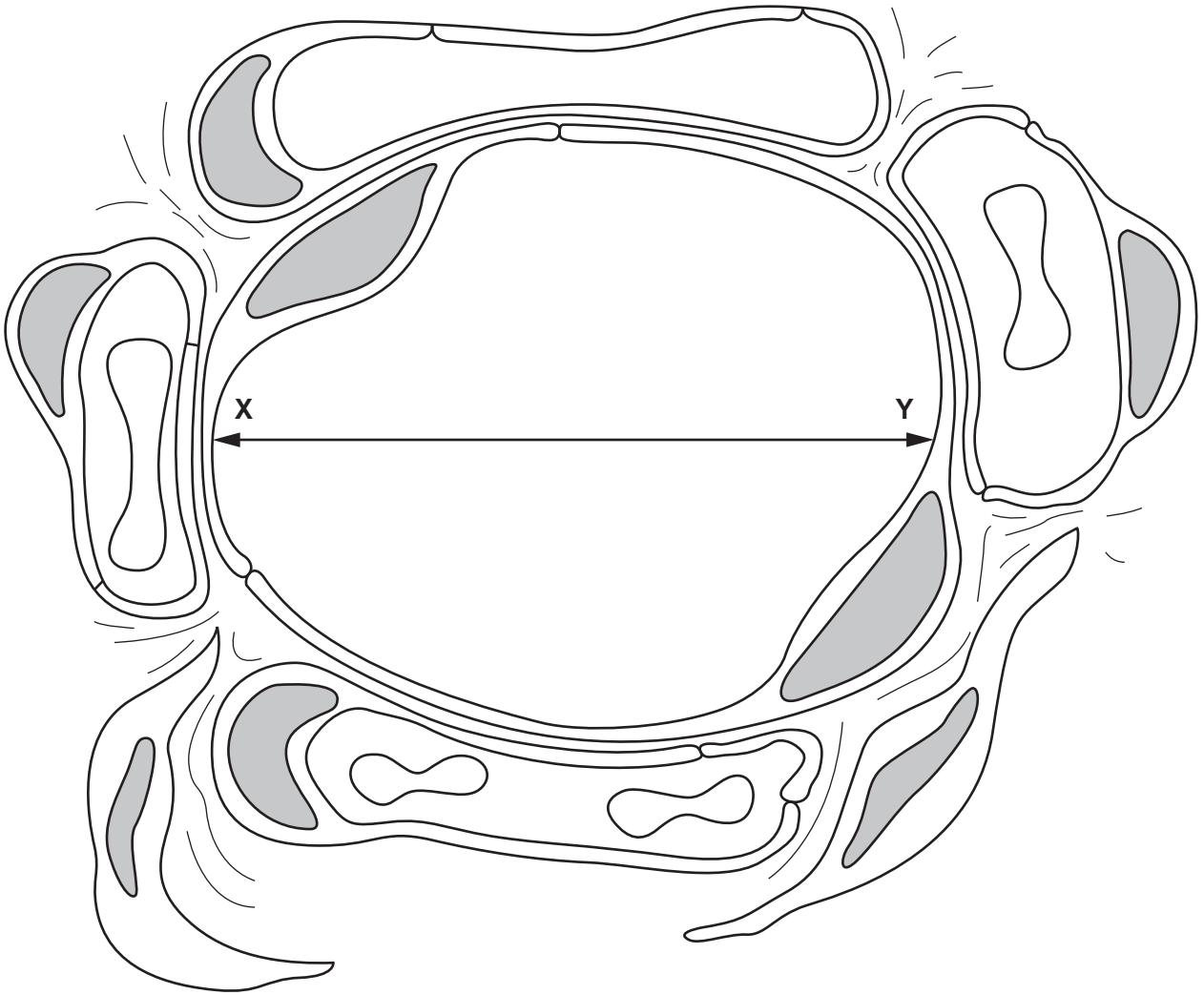

magnification $\times 3500$

Fig. 2.1

- (a) Calculate the actual diameter of the alveolus along the line X–Y.

Show your working and give your answer to the nearest micrometre.

Answer = μm [2]

(b) (i) Describe the role of elastic fibres in the wall of the alveolus.

.....
.....
.....
.....[2]

(ii) With reference to Fig. 2.1, explain how alveoli are adapted for gas exchange.

.....
.....
.....
.....
.....
.....
.....
.....
.....[4]

(c) Chronic obstructive pulmonary disease (COPD) is a progressive disease that develops in many smokers. COPD refers to two conditions:

- chronic bronchitis
- emphysema.

(i) State two ways in which the lung tissue of someone with emphysema differs from the lung tissue of someone with healthy lungs.

1.
2.[2]

(ii) State two symptoms of emphysema.

1.
.....
2.
.....[2]

[Total: 12]

3 (a) Fig. 3.1 shows a cross-section of the heart at the level of the valves.

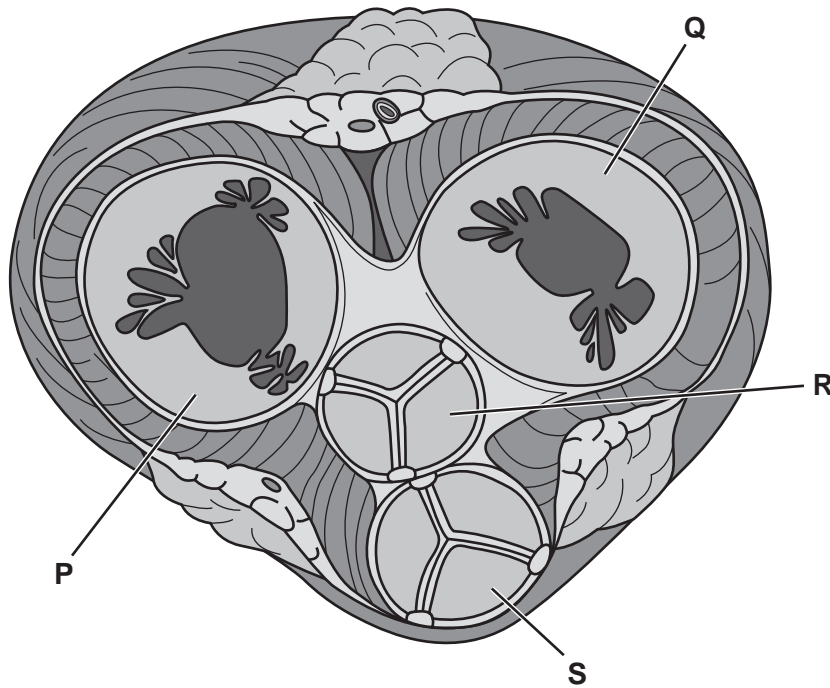
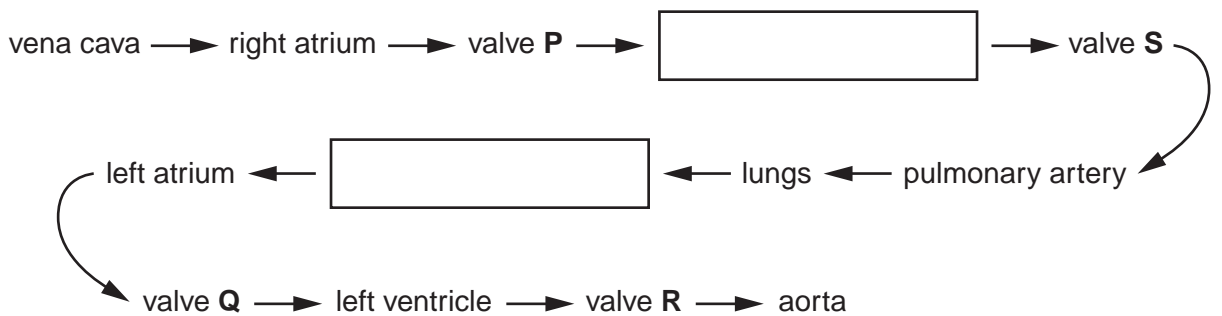

Fig. 3.1

(i) Complete the following flow chart to show the pathway of blood through the heart.



[2]

(ii) Explain how the valves P and Q ensure one-way flow of blood through the heart.

.....

.....

.....

..... [2]

(b) The cardiac cycle describes the events that occur during one heart beat.

Fig. 3.2 shows the changes in blood pressure that occur within the left atrium, left ventricle and aorta during one heart beat.

For
Examiner's
Use

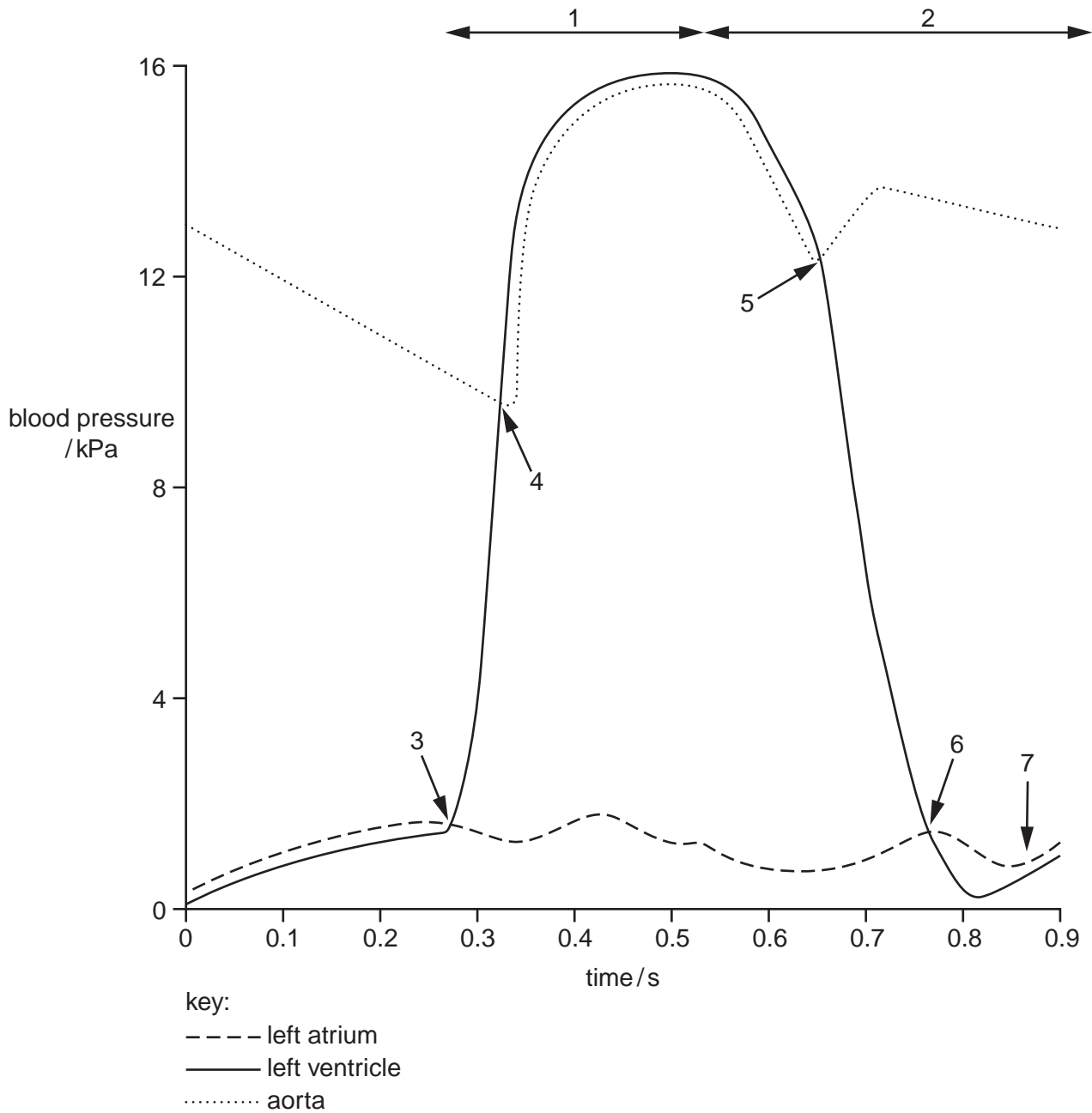

Fig. 3.2

4 Malaria and tuberculosis (TB) are two of the most important infectious diseases.

(a) Define the term *infectious disease*.

.....
..... [1]

(b) Describe how malaria is passed from an infected person to an uninfected person.

.....
.....
.....
.....
..... [2]

Fig. 4.1 shows the worldwide distribution of malaria.

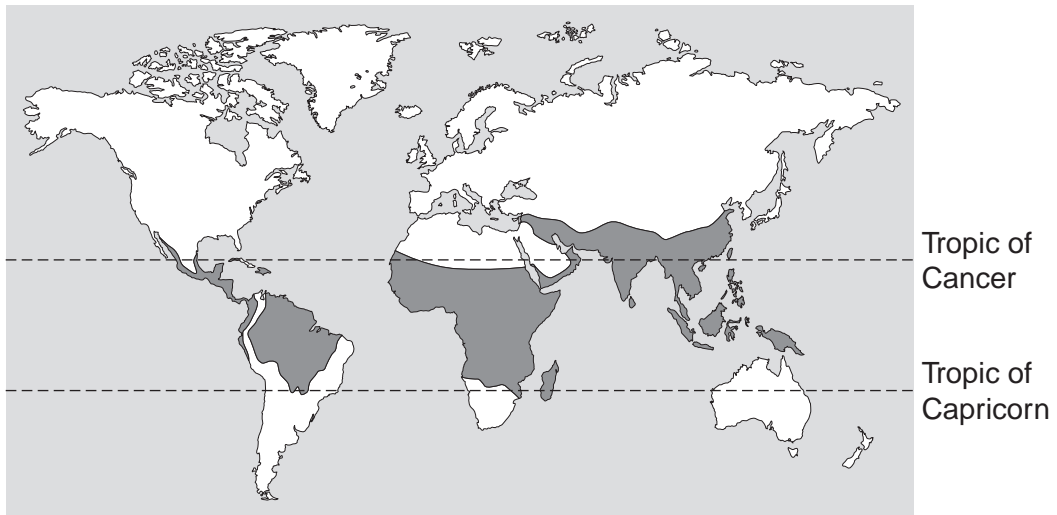

Key
□ malaria absent
■ malaria present

Fig. 4.1

5 (a) Name the stage during the mitotic cell cycle when replication of DNA occurs.

.....[1]

(b) Fig. 5.1 shows details of DNA replication.

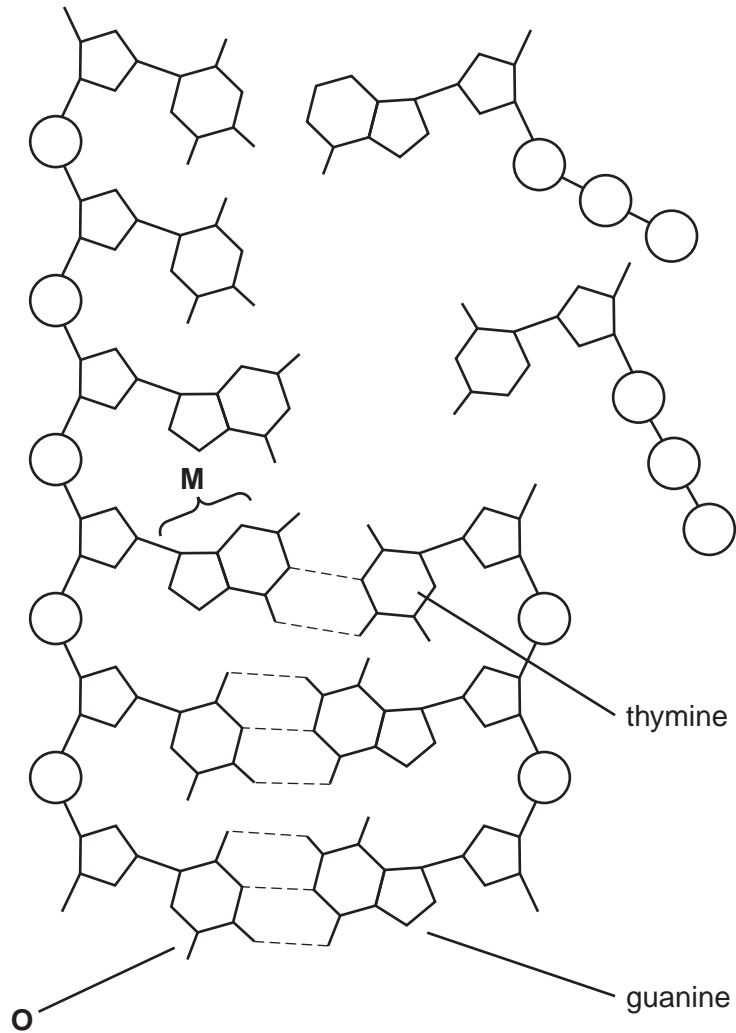

Fig. 5.1

(i) Name the bonds shown by the dashed lines on Fig. 5.1.

.....[1]

(ii) Name the nitrogenous bases, **M** and **O**.

M

O[1]

(c) Explain why DNA replication is described as *semi-conservative*.

.....
.....
.....
.....
..... [2]

(d) The enzyme that catalyses the replication of DNA checks for errors in the process and corrects them. This makes sure that the cells produced in mitosis are genetically identical.

Explain why checking for errors and correcting them is necessary.

.....
.....
.....
.....
..... [2]

[Total: 7]

- 6 Many species of legume grow in nitrate-deficient soils in the tropics. Some of these are large trees such as the flamboyant tree, *Delonix regia*.

For
Examiner's
Use

Bacteria of the genus *Rhizobium* live inside swellings along the roots of legumes. These swellings are known as root nodules.

A student followed the cycling of nitrogen in an area with many flamboyant trees.

Fig. 6.1 summarises the flow of nitrogen in the area.

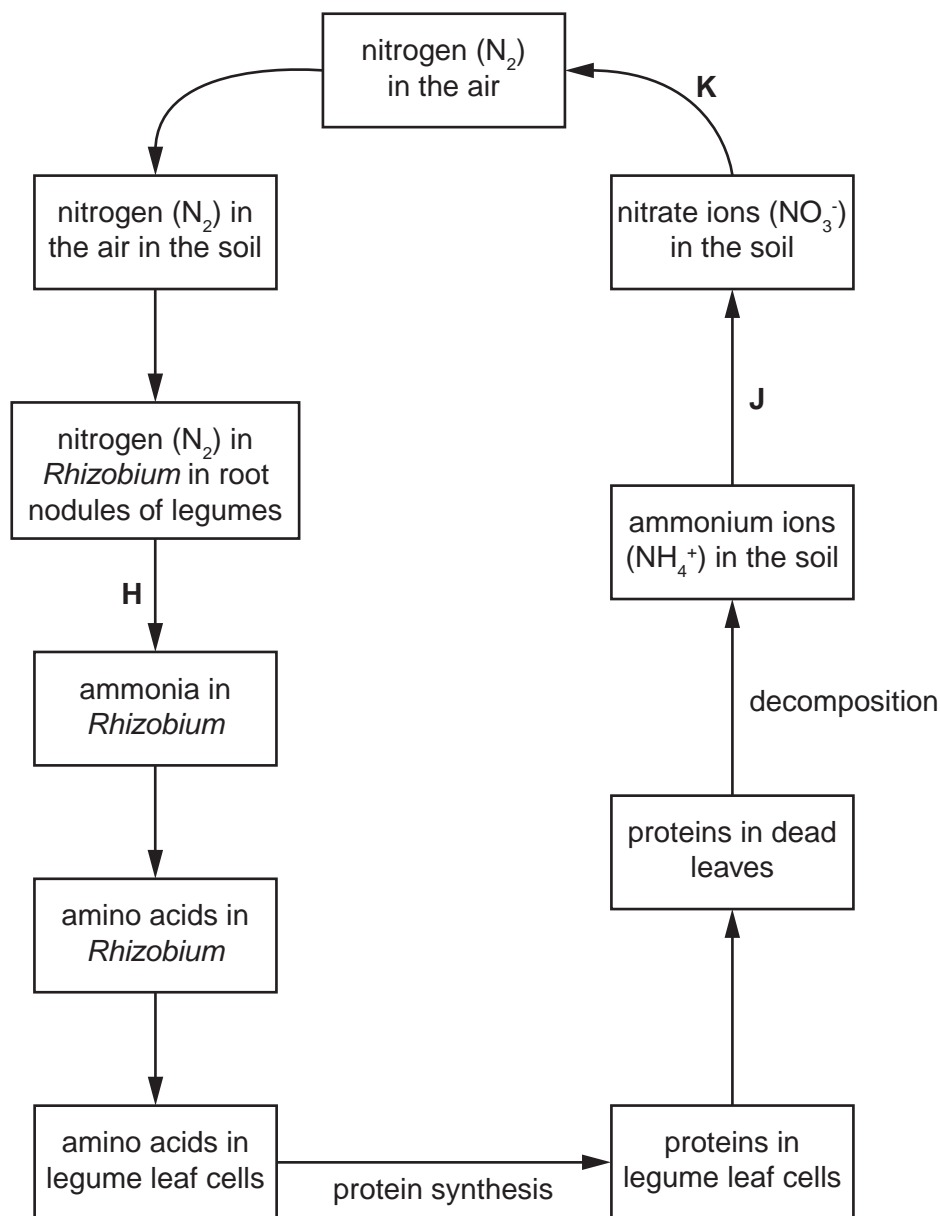

Fig. 6.1

- (a) Name the processes that occur at H, J and K.

H

J

K [3]

(b) Suggest the advantages gained by legumes of having *Rhizobium* living in their roots.

For
Examiner's
Use

.....

.....

.....

.....

.....

..... [2]

[Total: 5]

Permission to reproduce items where third-party owned material protected by copyright is included has been sought and cleared where possible. Every reasonable effort has been made by the publisher (UCLES) to trace copyright holders, but if any items requiring clearance have unwittingly been included, the publisher will be pleased to make amends at the earliest possible opportunity.

University of Cambridge International Examinations is part of the Cambridge Assessment Group. Cambridge Assessment is the brand name of University of Cambridge Local Examinations Syndicate (UCLES), which is itself a department of the University of Cambridge.