

**GAUTENG DEPARTMENT OF EDUCATION  
SENIOR CERTIFICATE EXAMINATION  
GAUTENGSE DEPARTEMENT VAN ONDERWYS  
SENIORSERTIFIKAAT-EKSAMEN**

**WELDING AND METALWORKING SG  
SWEIS EN METAALBEWERKING SG**

**POSSIBLE ANSWERS OCT / NOV 2006**

---

**SECTION / AFDELING A  
COMPULSORY / VERPLIGTEND**

**QUESTION / VRAAG 1**

1.1	1.1.1	TRUE	WAAR		
	1.1.2	TRUE	WAAR		
	1.1.3	TRUE	WAAR		
	1.1.4	TRUE	WAAR		
	1.1.5	TRUE	WAAR		
	1.1.6	FALSE	ONWAAR		
	1.1.7	FALSE	ONWAAR		
	1.1.8	FALSE	ONWAAR		
	1.1.9	TRUE	WAAR		
	1.1.10	TRUE	WAAR		
	1.1.11	TRUE	WAAR		
	1.1.12	TRUE	WAAR		
	1.1.13	TRUE	WAAR		
	1.1.14	FALSE	ONWAAR		
	1.1.15	FALSE	ONWAAR	(1 Mark each / 1 Punt elk)	(15)
1.2	1.2.1	N		1.2.11	J
	1.2.2	C		1.2.12	P
	1.2.3	S		1.2.13	H
	1.2.4	O		1.2.14	A
	1.2.5	R		1.2.15	B
	1.2.6	K		1.2.16	G
	1.2.7	T		1.2.17	D
	1.2.8	I		1.2.18	L
	1.2.9	M		1.2.19	F
	1.2.10	Q		1.2.20	E
					(1 Mark each / 1 Punt elk) (20)
1.3	1.3.1	C			
	1.3.2	D			
	1.3.3	B			
	1.3.4	C			
	1.3.5	C			
					(1 Mark each / 1 Punt elk) (5)

**[40]**

QUESTION 2 / VRAAG 2

2.1.1

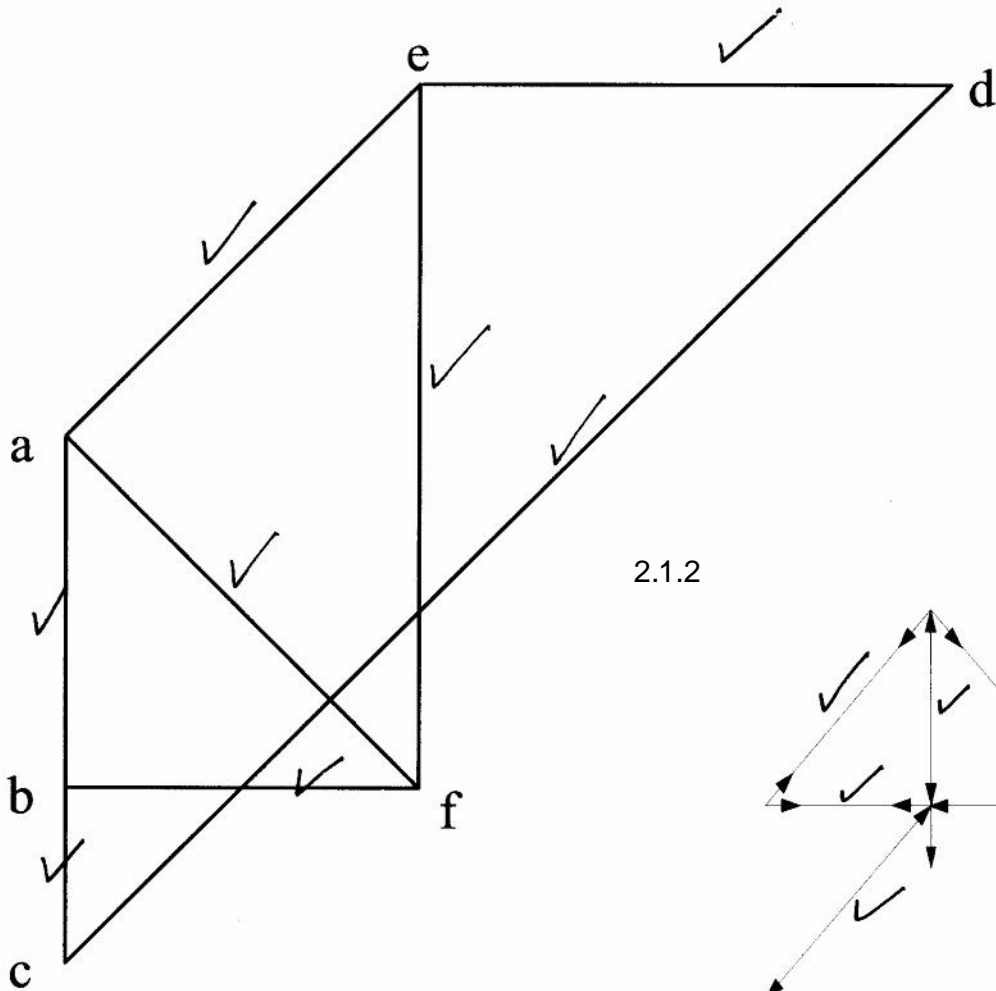

2.1.2

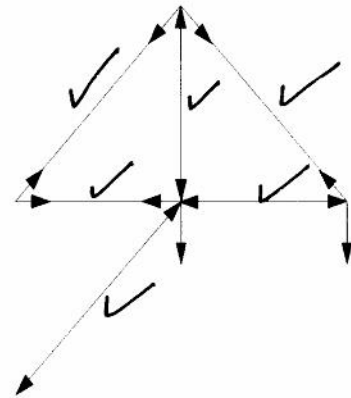

2.1.3

Member <i>Onderdeel</i>	Measurement (mm) <i>Afmeting (mm)</i>	Force (N) <i>Krag (N)</i>	Nature (tie or strut) <i>Aard (stut of stang)</i>	
AF	71	1 420 N	TIE	STANG
BF	50	1 000 N	STRUT	STUT
EF	100	2 000 N	STRUT	STUT
EA	71	1 420 N	TIE	STANG
ED	75	1 500 N	TIE	STANG
DC	177	3 540 N	STRUT	STUT
	(6)	(6)	(6)	

2.2 2.2.1

$$\frac{2 \text{ N}}{\text{m}} \times \frac{2 \text{ m}}{1} = 4 \text{ N} \quad (2)$$

2.2.2

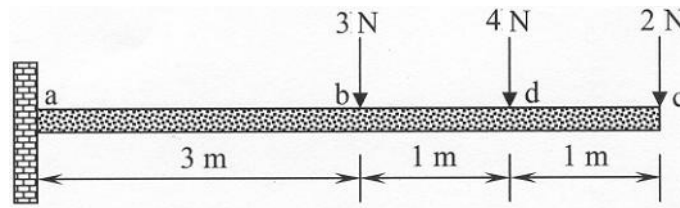

$$\text{BM}(C) = (-2 \text{ N} \times 0 \text{ m}) = 0 \text{ Nm}$$

$$\text{BM}(D) = (-2 \text{ N} \times 1 \text{ m}) = -2 \text{ Nm} \quad (2)$$

$$\text{BM}(B) = (-2 \text{ N} \times 2 \text{ m}) + (-4 \text{ N} \times 1 \text{ m}) = -8 \text{ Nm} \quad (2)$$

$$\text{BM}(A) = (-2 \text{ N} \times 5 \text{ m}) + (-4 \text{ N} \times 4 \text{ m}) + (-3 \text{ N} \times 3 \text{ m}) = -35 \text{ Nm} \quad (2)$$

**[40]****QUESTION / VRAAG 3**

3.1

$$(\text{LR} \times 10 \text{ m}) = (100 \text{ N} \times 6 \text{ m}) + (50 \text{ N} \times 4 \text{ m}) + (200 \text{ N} \times 1 \text{ m})$$

$$\text{LR} \cdot 10 \text{ m} = 600 \text{ Nm} + 200 \text{ Nm} + 200 \text{ Nm}$$

$$\text{LR} = \frac{1000 \text{ Nm}}{10 \text{ m}}$$

$$\text{LR} = 100 \text{ N} \quad (4)$$

$$(\text{RR} \times 10 \text{ m}) = (100 \text{ N} \times 4 \text{ m}) + (50 \text{ N} \times 6 \text{ m}) + (200 \text{ N} \times 9 \text{ m})$$

$$\text{RR} \cdot 10 \text{ m} = 400 \text{ Nm} + 300 \text{ Nm} + 1800 \text{ Nm}$$

$$\text{LR} = \frac{2500 \text{ Nm}}{10 \text{ m}}$$

$$\text{LR} = 250 \text{ N} \quad (4)$$

3.2

$$\text{BM}(D) = (+250 \text{ N} \times 1 \text{ m}) = 250 \text{ Nm}$$

$$\text{BM}(C) = (+250 \text{ N} \times 4 \text{ m}) + (-200 \text{ Nm} \times 3 \text{ m}) = 400 \text{ Nm}$$

$$\text{BM}(B) = (+250 \text{ Nm} \times 6 \text{ m}) + (-200 \text{ Nm} \times 5 \text{ m}) + (-50 \text{ Nm} \times 2 \text{ m}) = 400 \text{ Nm} \quad (6)$$

3.3

$$\text{SF} / \text{SK} (A) = 100 \text{ N}$$

$$\text{SF} / \text{SK} (B) = 100 \text{ N} - 100 \text{ N} = 0 \text{ N}$$

$$\text{SF} / \text{SK} (C) = 100 \text{ N} - 100 \text{ N} - 50 \text{ N} = -50 \text{ N}$$

$$\text{SF} / \text{SK} (D) = 100 \text{ N} - 100 \text{ N} - 50 \text{ N} - 200 \text{ N} = -250 \text{ N}$$

$$\text{SF} / \text{SK} (E) = 100 \text{ N} - 100 \text{ N} - 50 \text{ N} - 200 \text{ N} + 250 \text{ N} = 0 \text{ N} \quad (10)$$

3.4 & 3.5

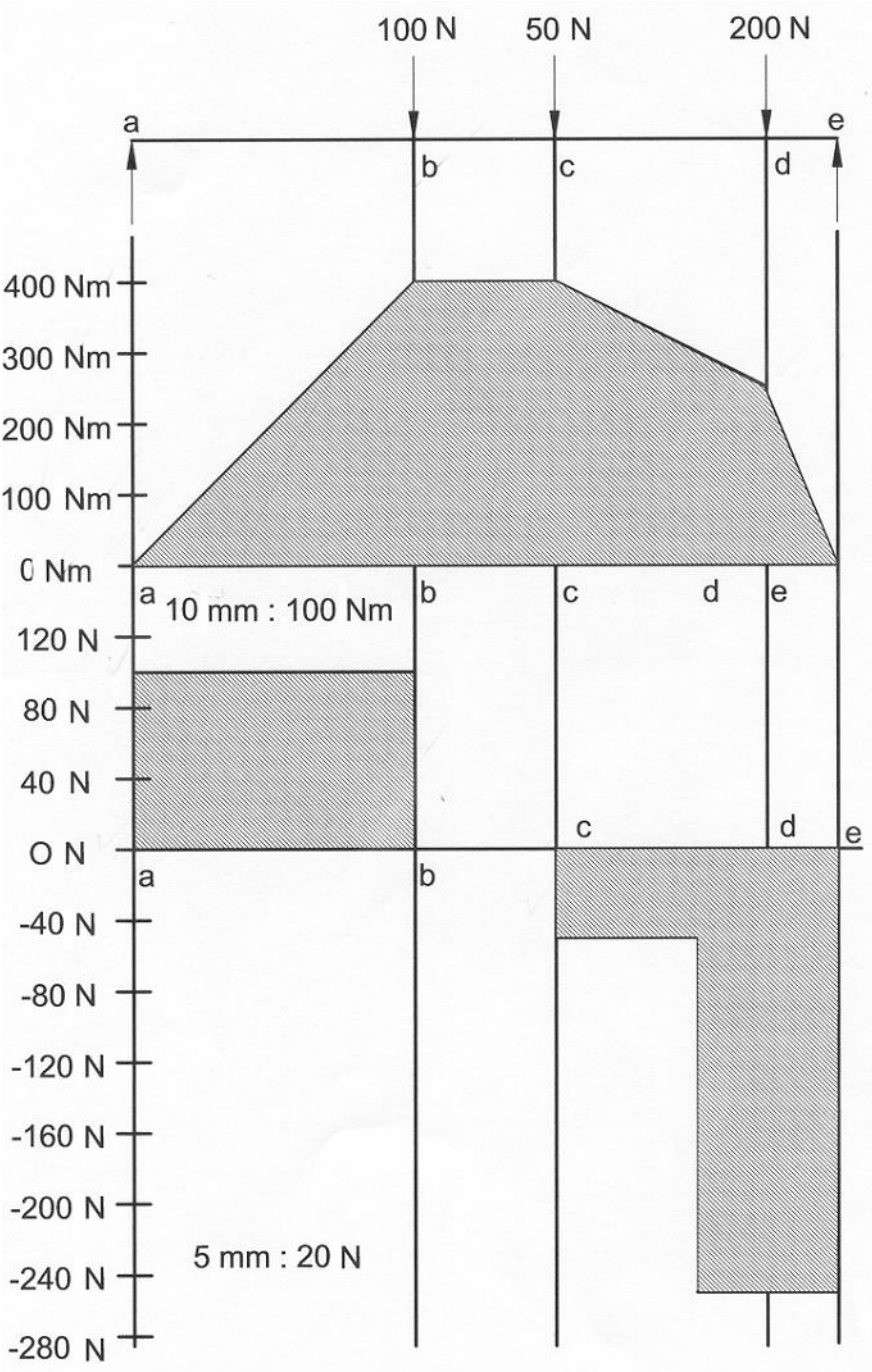

(8)

(8)

[40]

## QUESTION / VRAAG 4

## SYMBOLS USED / GEBRUIKTE SIMBOLE

$\delta$  - Stress / Spanning

$a$  = Area / Deursnee-oppervlakte

$F$  = Force / Belasting of krag

$E$  = Young's Modulus / Young se Modulus

$\Delta L$  = Change in length / Verandering in lengte

$S$  = Strain / Vormverandering

$OL$  = Original length / Oorspronklike lengte

## 4.1.1

$$d = \frac{F}{a}$$

$$d = \frac{120 \times 10^6 \text{ N}}{132,73 \times 10^{-6} \text{ m}^2}$$

$$d = 904,09 \times 10^9 \text{ Pa}$$

$$d = 904,09 \text{ GPa}$$

(5)

## 4.1.2

$$E = \frac{d}{S}$$

$$S = \frac{904,09 \times 10^9 \text{ Nm}^2}{18,08 \times 10^{12} \text{ Nm}^2}$$

$$S = 50 \times 10^{-3}$$

(5)

## 4.1.3

$$E = \frac{\Delta L}{OL}$$

$$E = \frac{7 \text{ mm}}{50 \times 10^{-3}}$$

$$E = 140 \text{ mm}$$

(5)

4.2.1

$$a = \frac{F}{d}$$

$$a = \frac{100 \times 10^3 \text{ Nm}^2}{2 \times 10^9 \text{ N}}$$

$$a = 50 \times 10^{-6} \text{ m}^2 \quad (5)$$

4.2.2

$$a = L \times B$$

$$L = \frac{a}{B}$$

$$L = \frac{50 \times 10^{-6} \text{ m}^2}{0,005 \text{ m}^2}$$

$$L = 10 \times 10^{-3} \text{ m}$$

$$L = 10 \text{ mm} \quad (5)$$

4.3

4.3.1

$$a = \frac{F}{d}$$

$$a = \frac{40 \times 10^3 \text{ Nm}^2}{226,36 \times 10^6 \text{ N}}$$

$$a = 176,71 \times 10^{-6} \text{ m}^2$$

$$a = \frac{pd^2}{4}$$

$$d = \sqrt{\frac{a \times 4}{p}}$$

$$d = \sqrt{\frac{176,71 \times 10^{-6} \times 4 \text{ m}^2}{p}}$$

$$d = 15 \times 10^{-3} \text{ m}$$

$$d = 15 \text{ mm} \quad (15)$$

## 5.1.1

Mark Merk	Quantity Aantal	Material Materiaal	Total mass per kg Totale massa per kg	Total mass Totale massa	Cos /kg Koste /kg	Amount Bedrag
AA	2	2x8=16 m	5,8 kg/m	92,8 kg	R8,95 /kg	R830,56
AB	2	2x4,5=9 m	5,8 kg/m	52,2 kg	R8,95 /kg	R467,19
C	3	3x4,5 = 13.5 m	4,47 kg/m	60,35 kg	R7,80 /kg	R286,66
D	4	4x4,92 = 19.68 m	4,47 kg/m		R7,80 /kg	R417,86
Welding material / Sweismateriaal						R225,00
Total material cost / Totale materiaalkoste						R2 227,27

(18)

## 5.1.2

Labour costs / arbeidskoste = Tariff per hour / tarief per uur x Hours worked / ure gewerk

$$= \frac{R75}{\text{per hour/per uur}} \times \frac{9 \text{ hours / ure}}{1}$$

$$= R675,00$$

(4)

## 5.1.3

Overhead costs / Drakoste = % allowed / toegelaat x Labour cost / Arbeidskoste

$$= \frac{95}{100} \times \frac{R675.00}{1}$$

$$= R641,25$$

(4)

## 5.1.4

Total cost = Material cost + Labour cost + Overhead cost

Totale koste = Materiaalkoste + Arbeidskoste + Drakoste

$$= R2 227,27 + R675,00 + R641,25$$

$$= R3 543,52$$

(4)

5.2

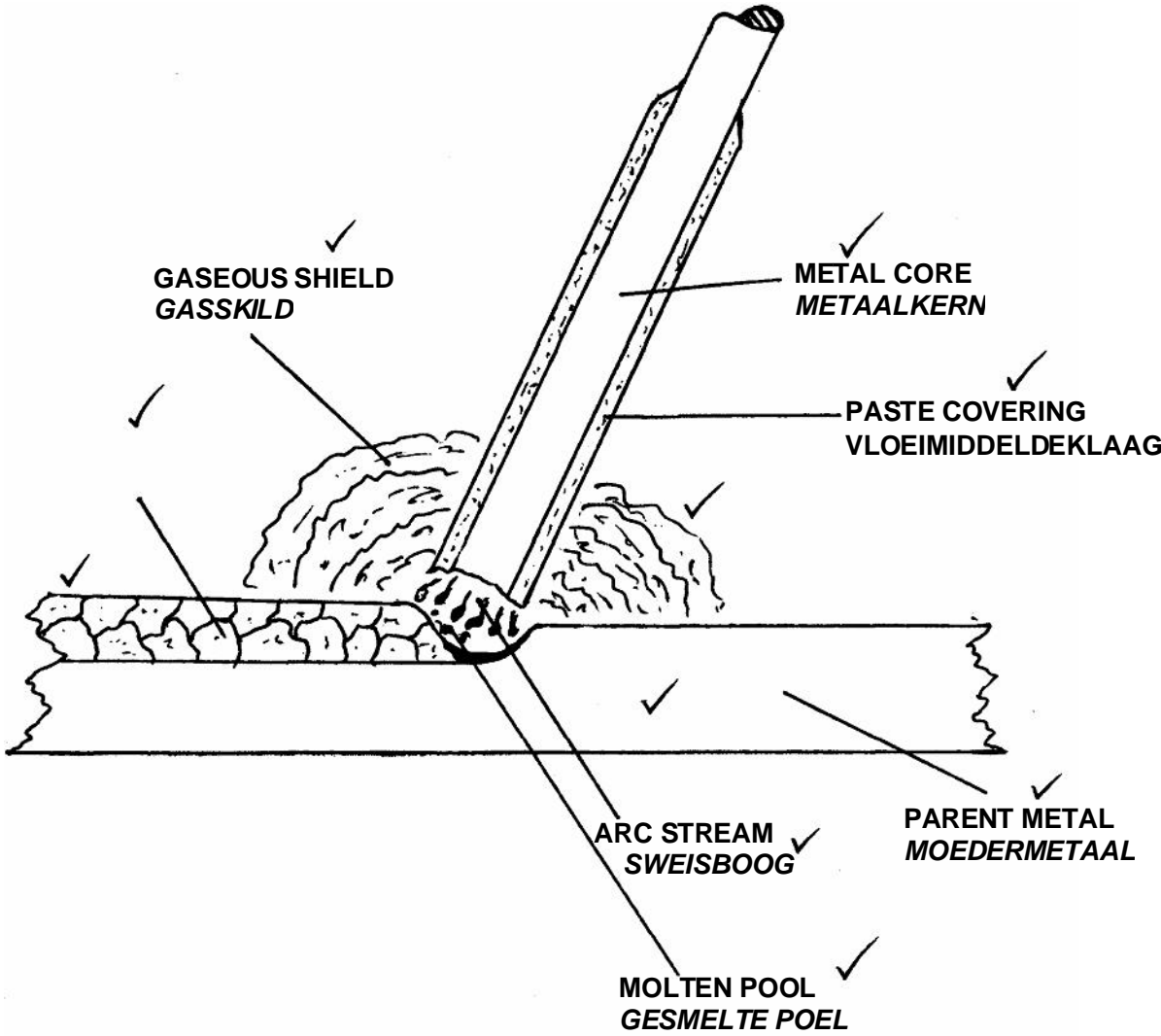

(10)  
[40]



## QUESTION / VRAAG 6

6.1.1

$$\text{Tan } a = \frac{BE}{EC}$$

$$EC = \frac{900}{\text{Tan } 68,75^\circ}$$

$$EC = 350 \text{ mm} \quad (5)$$

6.1.2

$$DC = (2 \times EC) + (AB)$$

$$DC = (2 \times 350 \text{ mm}) + 500 \text{ mm}$$

$$DC = 1200 \text{ mm} \quad (4)$$

6.1.3

$$\text{Sin } a = \frac{BE}{BC}$$

$$BC = \frac{900}{\text{Sin } 68,75^\circ}$$

$$BC = 965,66 \text{ mm} \quad (5)$$

6.1.4

$$\text{Cos } a = \frac{FC}{GC}$$

$$EC = \frac{600}{\text{Cos } 68,75^\circ}$$

$$EC = 1\,655,46 \text{ mm} \quad (5)$$

6.1.5

$$GC = GB + BC$$

$$GB = GC - BC$$

$$EC = 1\,655,46 - 965,66$$

$$= 689,8 \text{ mm} \quad (5)$$

$$\text{Cos } a = \frac{1}{2} \frac{(AB)}{GB}$$

$$GB = \frac{1}{2} \frac{500}{\text{Cos } 68,75^\circ} \quad (5)$$

$$GB = 689,8 \text{ mm}$$

6.2

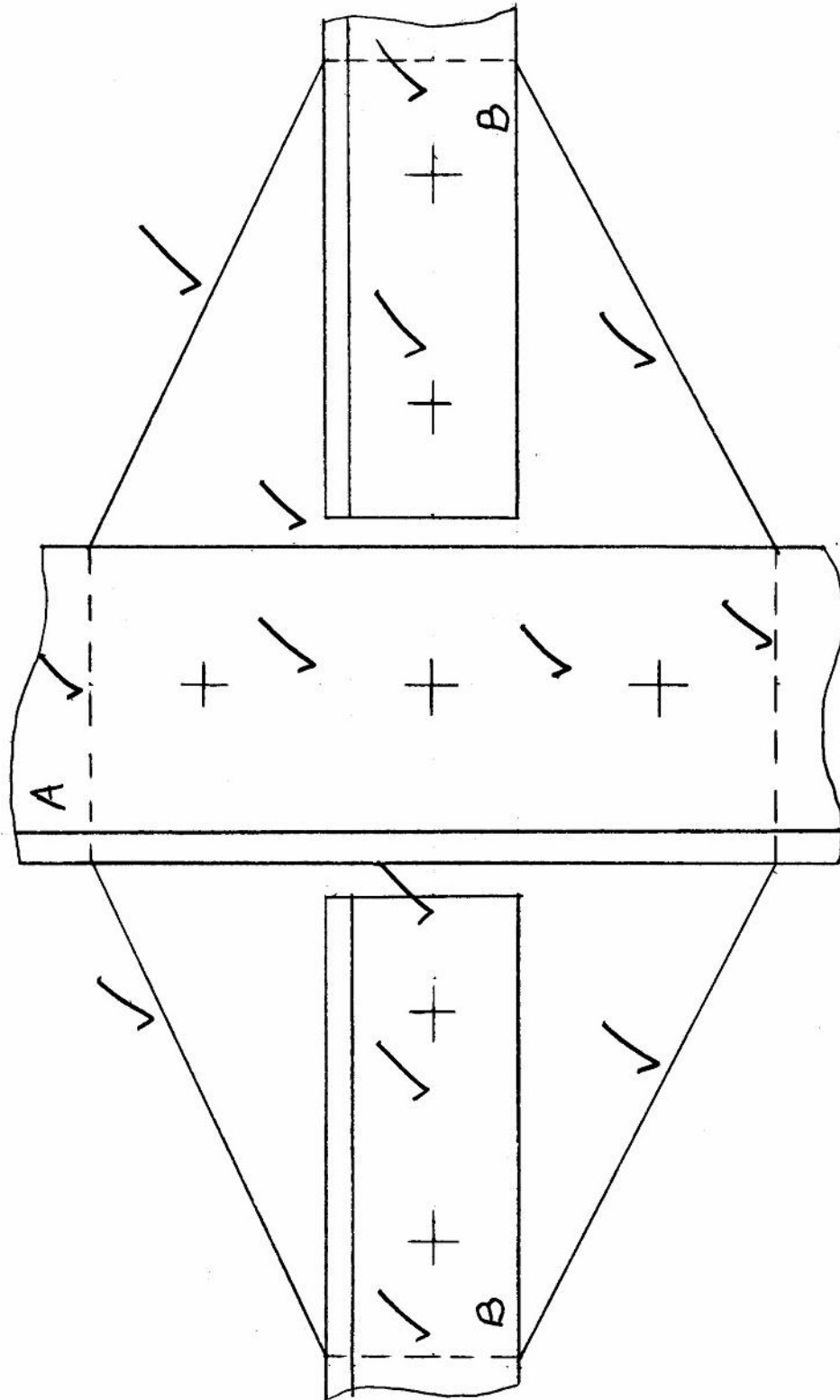

(16)